

CAT5172

Digital Potentiometer (POT), 256-Tap, SPI Compatible

The CAT5172 is a 256-position digital linear taper potentiometer ideally suited for replacing mechanical potentiometers and variable resistors. Like mechanical potentiometers, the CAT5172 has a resistive element, which can span V_{CC} to Ground or float anywhere between the power supply rails.

Wiper settings are controlled through an SPI-compatible digital interface. Upon power-up, the wiper assumes a mid-span position and may be repositioned anytime after the power is stable.

The CAT5172 operates from 2.7 V to 5.5 V, while consuming less than 2 μ A. This low operating current, combined with a small package footprint, make the CAT5172 ideal for battery-powered portable appliance.

Features

- 256-position
- End-to-End Resistance: 50 k Ω , 100 k Ω
- SPI Compatible Interface
- Power-on Preset to Midscale
- Single Supply 2.7 V to 5.5 V
- Low Temperature Coefficient 100 ppm/ $^{\circ}$ C
- Low Power, I_{DD} 2 μ A max
- Wide Operating Temperature -40° C to $+85^{\circ}$ C
- SOT-23 8-lead (2.9 mm \times 3 mm) Package
- These Devices are Pb-Free, Halogen Free/BFR Free and are RoHS Compliant

Typical Applications

- Potentiometer Replacement
- Transducer Adjustment of Pressure, Temperature, Position, Chemical, and Optical Sensors
- RF Amplifier Biasing
- Gain Control and Offset Adjustment



ON Semiconductor®

<http://onsemi.com>

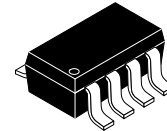

SOT23-8
TB SUFFIX
CASE 527AK

MARKING DIAGRAM

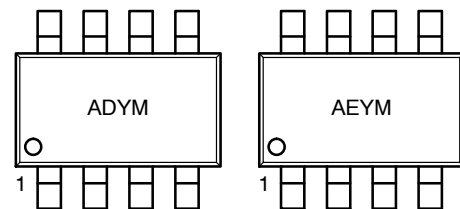

AD = 50 k Ω
AE = 100 k Ω
Y = Production Year
(Last Digit)
M = Production Month
(1 - 9, A, B, C)

PIN CONNECTIONS

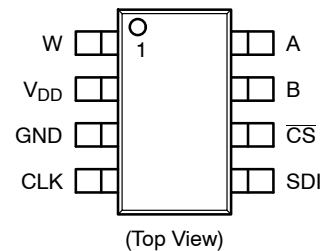

ORDERING INFORMATION

See detailed ordering and shipping information in the package dimensions section on page 2 of this data sheet.

CAT5172

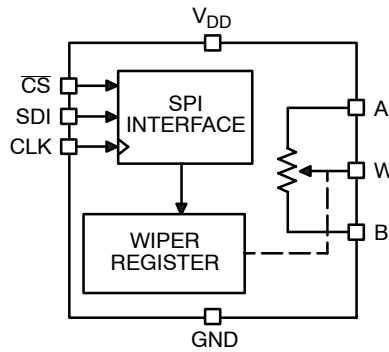

Figure 1. Functional Block Diagram

Table 1. ORDERING INFORMATION

Part Number	Resistance	Temperature Range	Package	Shipping [†]
CAT5172TBI-50GT3	50 kΩ	-40°C to 85°C	SOT-23-8 (Pb-Free)	3000/Tape & Reel
CAT5172TBI-00GT3	100 kΩ			3000/Tape & Reel

[†]For information on tape and reel specifications, including part orientation and tape sizes, please refer to our Tape and Reel Packaging Specifications Brochure, BRD8011/D.

1. For detailed information and a breakdown of device nomenclature and numbering systems, please see the ON Semiconductor Device Nomenclature document, TND310/D, available at www.onsemi.com.

Table 2. PIN FUNCTION DESCRIPTION

Pin No.	Pin Name	Description
1	W	Resistor's Wiper Terminal.
2	V _{DD}	Positive Power Supply.
3	GND	Digital Ground.
4	CLK	Serial Clock Input. Positive edge triggered.
5	SDI	Serial Data Input.
6	CS	Chip Select Input, Active Low. When CS returns high, data will be loaded into the DAC register.
7	B	Bottom Terminal of resistive element.
8	A	Top Terminal of resistive element.

Table 3. ABSOLUTE MAXIMUM RATINGS (Note 2)

Rating	Value	Unit
V _{DD} to GND	-0.3 to 6.5	V
V _A , V _B , V _W to GND	V _{DD}	
I _{MAX}	±20	mA
Digital Inputs and Output Voltage to GND	0 to 6.5	V
Operating Temperature Range	-40 to +85	°C
Maximum Junction Temperature (T _{JMAX})	150	°C
Storage Temperature	-65 to +150	°C
Lead Temperature (Soldering, 10 sec)	300	°C

Stresses exceeding Maximum Ratings may damage the device. Maximum Ratings are stress ratings only. Functional operation above the Recommended Operating Conditions is not implied. Extended exposure to stresses above the Recommended Operating Conditions may affect device reliability.

2. Maximum terminal current is bounded by the maximum current handling of the switches, maximum power dissipation of the package, and maximum applied voltage across any two of the A, B, and W terminals at a given resistance.

CAT5172

Table 4. ELECTRICAL CHARACTERISTICS: 50 kΩ and 100 kΩ Versions

$V_{DD} = 5\text{ V} \pm 10\%$, or $3\text{ V} \pm 10\%$; $V_A = V_{DD}$; $V_B = 0\text{ V}$; $-40^\circ\text{C} < T_A < +85^\circ\text{C}$; unless otherwise noted.

Parameter	Test Conditions	Symbol	Min	Typ (Note 3)	Max	Unit
-----------	-----------------	--------	-----	--------------	-----	------

DC CHARACTERISTICS – RHEOSTAT MODE

Resistor Differential Nonlinearity (Note 4)	R_{WB} , $V_A = \text{no connection}$	R–DNL	–1	± 0.1	+1	LSB
Resistor Integral Nonlinearity (Note 4)	R_{WB} , $V_A = \text{no connection}$	R–INL	–2	± 0.4	+2	LSB
Nominal Resistor Tolerance (Note 5)	$T_A = 25^\circ\text{C}$	ΔR_{AB}	–20		+20	%
Resistance Temperature Coefficient	$V_{AB} = V_{DD}$, Wiper = no connection	$\Delta R_{AB}/\Delta T$		100		ppm/ $^\circ\text{C}$
Wiper Resistance	$V_{DD} = 5\text{ V}$	R_W		50	120	Ω
	$V_{DD} = 3\text{ V}$			100	250	

DC CHARACTERISTICS – POTENTIOMETER DIVIDER MODE

Resolution		N			8	Bits
Differential Nonlinearity (Note 6)		DNL	–1	± 0.1	+1	LSB
Integral Nonlinearity (Note 6)		INL	–1	± 0.4	+1	LSB
Voltage Divider Temperature Coefficient	Code = 0x80	$\Delta V_W/\Delta T$		100		ppm/ $^\circ\text{C}$
Full-Scale Error	Code = 0xFF	V_{WFSE}	–3	–1	0	LSB
Zero-Scale Error	Code = 0x00	V_{WZSE}	0	1	3	LSB

RESISTOR TERMINALS

Voltage Range (Note 7)		$V_{A,B,W}$	GND		V_{DD}	V
Capacitance (Note 8) A, B	f = 1 MHz, measured to GND, Code = 0 x 80	$C_{A,B}$		45		pF
Capacitance (Note 8) W	f = 1 MHz, measured to GND, Code = 0 x 80	C_W		60		pF
Common-Mode Leakage (Note 8)	$V_A = V_B = V_{DD}/2$	I_{CM}		1		nA

DIGITAL INPUTS

Input Logic High	$V_{DD} = 5\text{ V}$	V_{IH}	$0.7 \times V_{DD}$			V
Input Logic Low	$V_{DD} = 5\text{ V}$	V_{IL}			$0.3V_{DD}$	V
Input Logic High	$V_{DD} = 3\text{ V}$	V_{IH}	$0.7 \times V_{DD}$			V
Input Logic Low	$V_{DD} = 3\text{ V}$	V_{IL}			$0.3V_{DD}$	V
Input Current	$V_{IN} = 0\text{ V}$ or 5 V	I_{IL}			± 1	μA
Input Capacitance (Note 8)		C_{IL}		5		pF

POWER SUPPLIES

Power Supply Range		$V_{DD\text{ RANGE}}$	2.7		5.5	V
Supply Current	$V_{IH} = 5\text{ V}$ or $V_{IL} = 0\text{ V}$	I_{DD}		0.3	2	μA
Power Dissipation (Note 9)	$V_{IH} = 5\text{ V}$ or $V_{IL} = 0\text{ V}$, $V_{DD} = 5\text{ V}$	P_{DISS}			0.2	mW
Power Supply Sensitivity	$\Delta V_{DD} = +5\text{ V} \pm 10\%$, Code = Midscale	PSS			± 0.05	%/%

- Typical specifications represent average readings at $+25^\circ\text{C}$ and $V_{DD} = 5\text{ V}$.
- Resistor position nonlinearity error R–INL is the deviation from an ideal value measured between the maximum resistance and the minimum resistance wiper positions. R–DNL measures the relative step change from ideal between successive tap positions. Parts are guaranteed monotonic.
- $V_{AB} = V_{DD}$, Wiper (V_W) = no connect.
- INL and DNL are measured at VW with the digital POT configured as a potentiometer divider similar to a voltage output D/A converter. $V_A = V_{DD}$ and $V_B = 0\text{ V}$. DNL specification limits of ± 1 LSB maximum are guaranteed monotonic operating conditions.
- Resistor terminals A, B, W have no limitations on polarity with respect to each other.
- Guaranteed by design and not subject to production test.
- P_{DISS} is calculated from ($I_{DD} \times V_{DD}$). CMOS logic level inputs result in minimum power dissipation.
- All dynamic characteristics use $V_{DD} = 5\text{ V}$.

CAT5172

Table 4. ELECTRICAL CHARACTERISTICS: 50 kΩ and 100 kΩ Versions (continued)

$V_{DD} = 5\text{ V} \pm 10\%$, or $3\text{ V} \pm 10\%$; $V_A = V_{DD}$; $V_B = 0\text{ V}$; $-40^\circ\text{C} < T_A < +85^\circ\text{C}$; unless otherwise noted.

Parameter	Test Conditions	Symbol	Min	Typ (Note 3)	Max	Unit
DYNAMIC CHARACTERISTICS (Notes 8 and 10)						
Bandwidth -3 dB	$R_{AB} = 50\text{ k}\Omega / 100\text{ k}\Omega$, Code = 0x80	BW		100/40		kHz
Total Harmonic Distortion	$V_A = 1\text{ V rms}$, $V_B = 0\text{ V}$, $f = 1\text{ kHz}$, $R_{AB} = 10\text{ k}\Omega$	THD _W		0.05		%
V _W Settling Time (50 kΩ/100 kΩ)	$V_A = 5\text{ V}$, $V_B = 0\text{ V}$, $\pm 1\text{ LSB error band}$	t _S		2		μs

- Typical specifications represent average readings at $+25^\circ\text{C}$ and $V_{DD} = 5\text{ V}$.
- Resistor position nonlinearity error R-INL is the deviation from an ideal value measured between the maximum resistance and the minimum resistance wiper positions. R-DNL measures the relative step change from ideal between successive tap positions. Parts are guaranteed monotonic.
- $V_{AB} = V_{DD}$, Wiper (V_W) = no connect.
- INL and DNL are measured at VW with the digital POT configured as a potentiometer divider similar to a voltage output D/A converter. $V_A = V_{DD}$ and $V_B = 0\text{ V}$. DNL specification limits of $\pm 1\text{ LSB}$ maximum are guaranteed monotonic operating conditions.
- Resistor terminals A, B, W have no limitations on polarity with respect to each other.
- Guaranteed by design and not subject to production test.
- PDISS is calculated from $(I_{DD} \times V_{DD})$. CMOS logic level inputs result in minimum power dissipation.
- All dynamic characteristics use $V_{DD} = 5\text{ V}$.

Table 5. TIMING CHARACTERISTICS: 50 kΩ and 100 kΩ Versions

$V_{DD} = 5\text{ V} \pm 10\%$, or $3\text{ V} \pm 10\%$; $V_A = V_{DD}$; $V_B = 0\text{ V}$; $-40^\circ\text{C} < T_A < +85^\circ\text{C}$; unless otherwise noted.

Parameter	Test Conditions	Symbol	Min	Typ (Note 11)	Max	Unit
-----------	-----------------	--------	-----	------------------	-----	------

SPI INTERFACE TIMING CHARACTERISTICS (Notes 12 and 13) (Specifications Apply to All Parts)

Clock Frequency		f _{CLK}			25	MHz
Input Clock Pulse width	Clock level high or low	t _{CH} , t _{CL}	20			ns
Data Setup Time		t _{DS}	5			ns
Data Hold Time		t _{DH}	5			ns
$\overline{\text{CS}}$ Setup Time		T _{CSS}	15			ns
$\overline{\text{CS}}$ High Pulse Width		T _{CSW}	40			ns
CLK Fall to $\overline{\text{CS}}$ Fall Hold Time		T _{CSH0}	0			ns
CLK Fall to $\overline{\text{CS}}$ Rise Hold Time		T _{CSH1}	0			ns
$\overline{\text{CS}}$ Rise to Clock Rise Setup		T _{CS1}	10			ns

- Typical specifications represent average readings at $+25^\circ\text{C}$ and $V_{DD} = 5\text{ V}$.
- Guaranteed by design and not subject to production test.
- See timing diagram for location of measured values. All input control voltages are specified with $t_R = t_F = 2\text{ ns}$ (10% to 90% of 3 V) and timed from a voltage level of 1.5 V.

CAT5172

SPI INTERFACE

Table 6. CAT5172 SERIAL DATA-WORD FORMAT

B7	B6	B5	B4	B3	B2	B1	B0
D7 MSB 2 ⁷	D6	D5	D4	D3	D2	D1	D0 LSB 2 ⁰

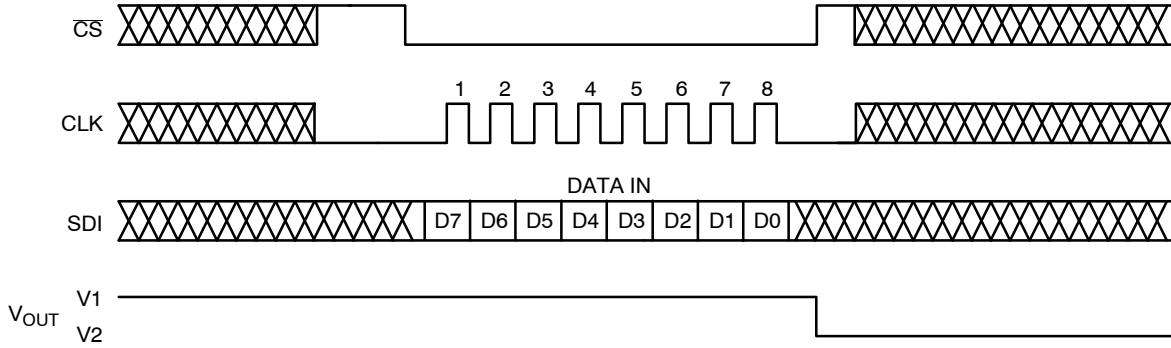

Figure 2. CAT5172 SPI Interface Timing Diagram ($V_A = 5\text{ V}$, $V_B = 0\text{ V}$, $V_W = V_{OUT}$)

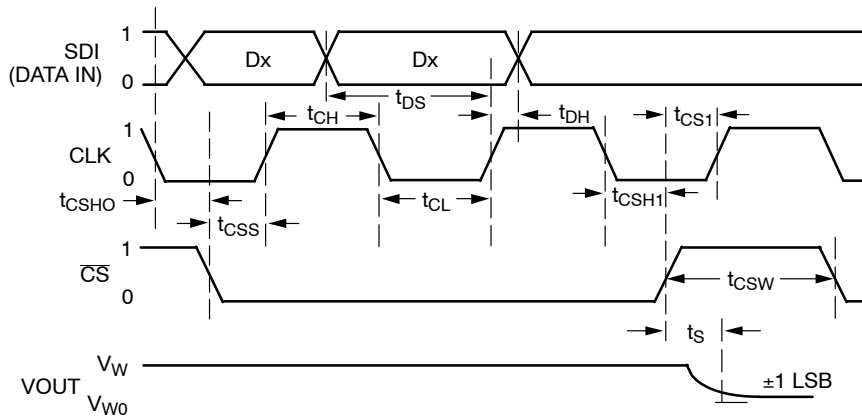

Figure 3. SPI Interface Detailed Timing Diagram ($V_A = 5\text{ V}$, $V_B = 0\text{ V}$, $V_W = V_{OUT}$)

TYPICAL CHARACTERISTICS

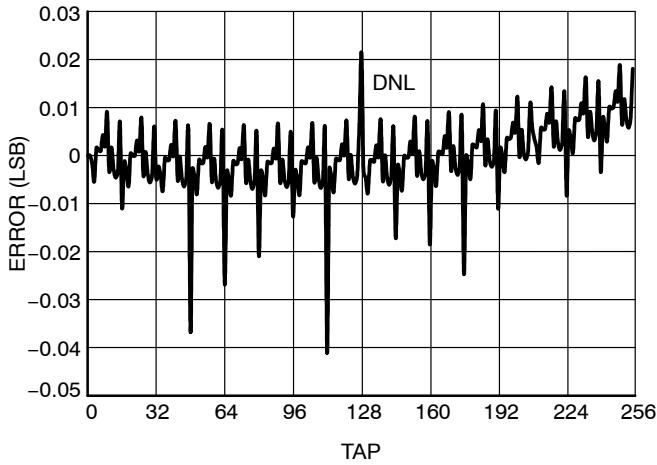

Figure 4. Differential Non-Linearity,
 $V_{CC} = 5.6\text{ V}$

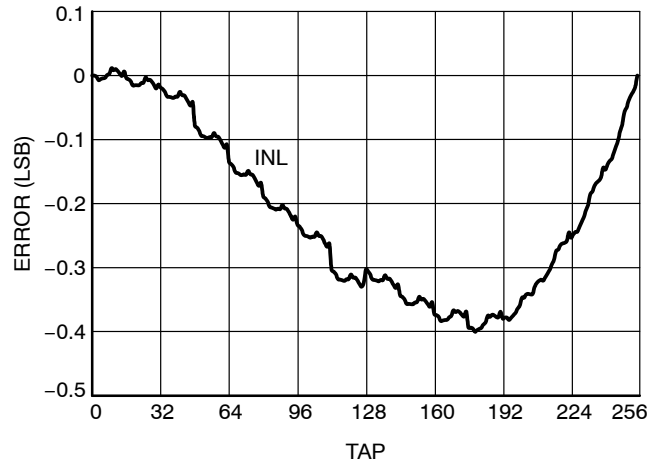

Figure 5. Integral Non-Linearity,
 $V_{CC} = 5.6\text{ V}$

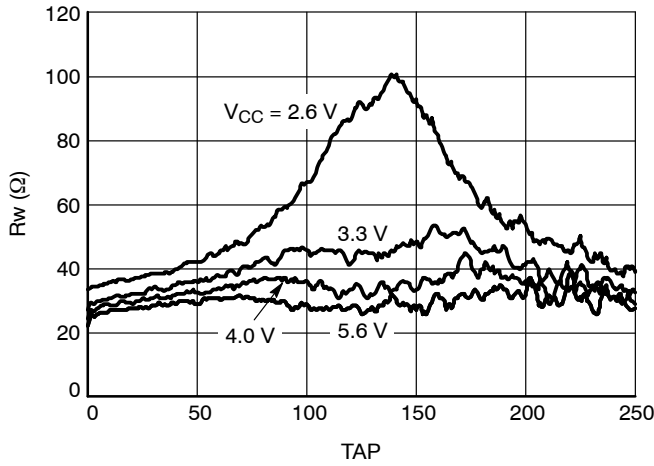

Figure 6. Wiper Resistance at Room
Temperature

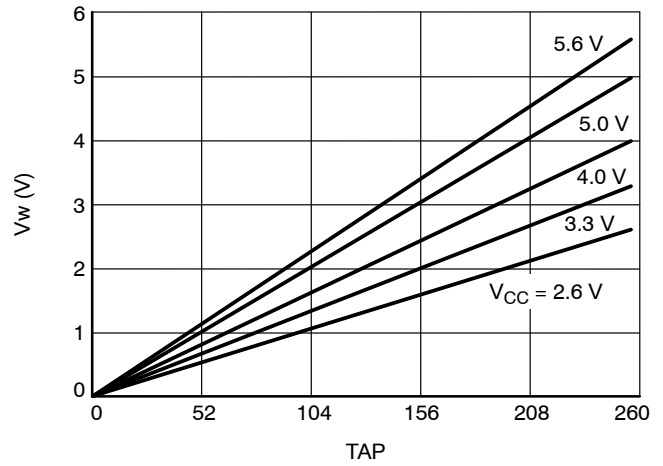

Figure 7. Wiper Voltage

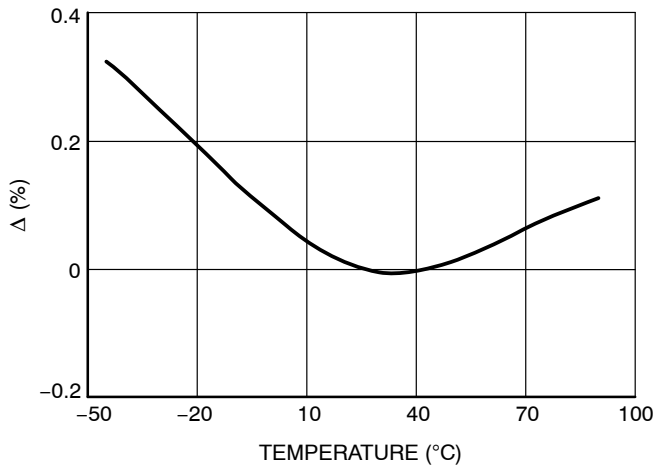

Figure 8. Change in End-to-End Resistance

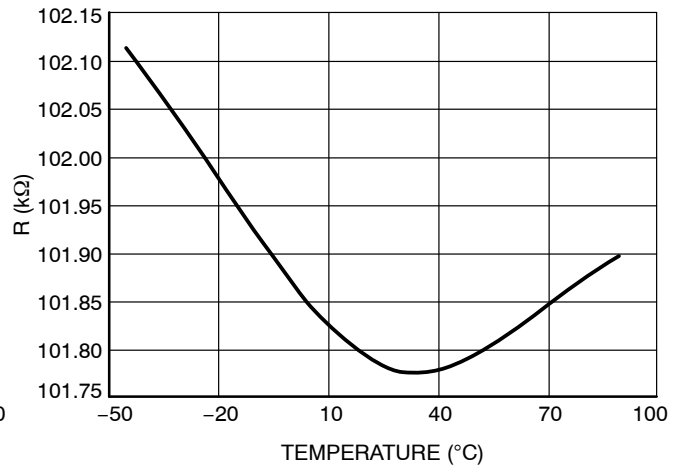

Figure 9. End-to-End Resistance vs.
Temperature

CAT5172

TYPICAL CHARACTERISTICS

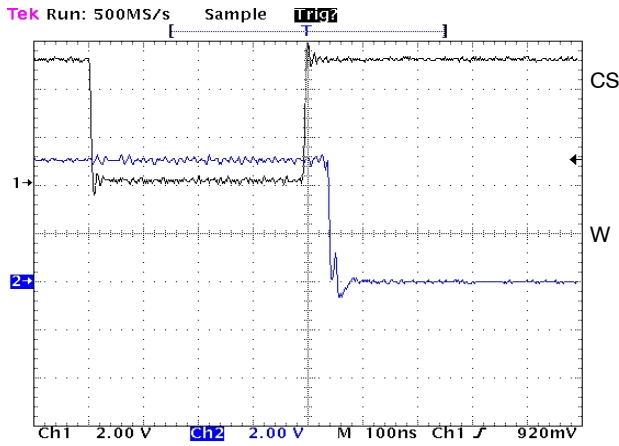

Figure 10. Wiper's Transition from Position 0xFF to Position 0x00 Relative to the CS Disable, $V_{CC} = 5\text{ V}$

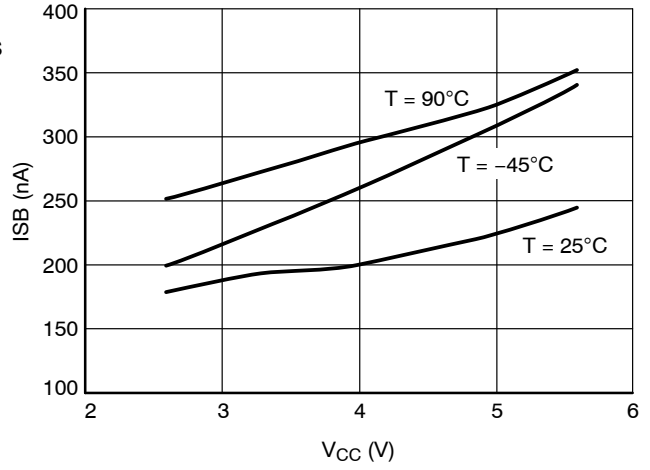

Figure 11. Standby Current

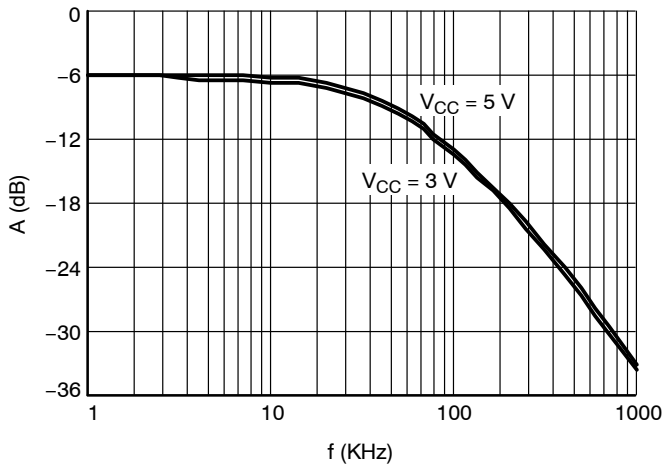

Figure 12. Gain vs. Bandwidth (Tap 0x80)

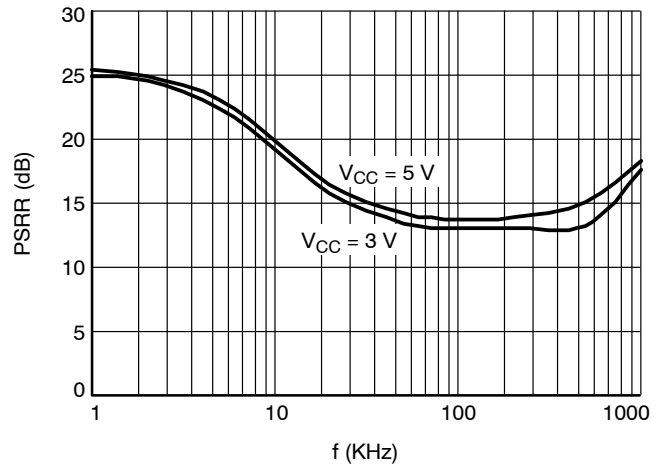

Figure 13. PSRR

BASIC OPERATION

The CAT5172 is a 256-position digitally controlled potentiometer. When power is first applied the wiper assumes a mid-scale position and will remain there as long as \overline{CS} remains high. Once the power supply is stable the wiper may be repositioned via the SPI compatible interface. The rising edge of the \overline{CS} signal acts as the transfer command and each time \overline{CS} transitions from LOW to HIGH the contents of the input register are loaded into the wiper register.

In the power-up cycle, the input data register is cleared, setting all bits to 0 and the wiper register is loaded with 0x80 (128 Decimal) which moves the wiper to its midscale position. If \overline{CS} is toggled CAT5172 transfers the contents of the input data register (0x00) to the wiper register moving the wiper to the bottom-most position (W = terminal B). This transfer is independent of whether new data has been input or not because \overline{CS} acts as the transfer command.

PROGRAMMING: VARIABLE RESISTOR

Rheostat Mode

The resistance between terminals A and B, R_{AB} , has a nominal value of 50 k Ω or 100 k Ω and has 256 contact points accessed by the wiper terminal, plus the B terminal contact. Data in the 8-bit Wiper register is decoded to select one of these 256 possible settings.

The wiper's first connection is at the B terminal, corresponding to control position 0x00. Ideally this would present a 0 Ω between the Wiper and B, but just as with a mechanical rheostat there is a small amount of contact resistance to be considered, there is a wiper resistance comprised of the R_{ON} of the FET switch connecting the wiper output with its respective contact point. In CAT5172 this 'contact' resistance is typically 50 Ω . Thus a connection setting of 0x00 yields a minimum resistance of 50 Ω between terminals W and B.

For a 100 k Ω device, the second connection, or the first tap point, corresponds to 441 Ω ($R_{WB} = R_{AB}/256 + R_W = 390.6 + 50 \Omega$) for data 0x01. The third connection is the next tap point, is 831 Ω ($2 \times 390.6 + 50 \Omega$) for data 0x02, and so on. Figure 14 shows a simplified equivalent circuit where the last resistor string will not be accessed; therefore, there is 1 LSB less of the nominal resistance at full scale in addition to the wiper resistance.

The equation for determining the digitally programmed output resistance between W and B is

$$R_{WB} = \frac{D}{256} R_{AB} + R_W \quad (\text{eq. 1})$$

where D is the decimal equivalent of the binary code loaded in the 8-bit Wiper register, R_{AB} is the end-to-end resistance, and R_W is the wiper resistance contributed by the on resistance of the internal switch.

In summary, if $R_{AB} = 100 \text{ k}\Omega$ and the A terminal is open circuited, the following output resistance R_{WB} will be set for the indicated Wiper register codes:

Table 7. CODES AND CORRESPONDING R_{WB} RESISTANCE FOR $R_{AB} = 100 \text{ k}\Omega$, $V_{DD} = 5 \text{ V}$

D (Dec.)	$R_{WB} (\Omega)$	Output State
255	99,559	Full Scale ($R_{AB} - 1 \text{ LSB} + R_W$)
128	50,050	Midscale
1	441	1 LSB
0	50	Zero Scale (Wiper Contact Resistance)

Be aware that in the zero-scale position, the wiper resistance of 50 Ω is still present. Current flow between W and B in this condition should be limited to a maximum pulsed current of no more than 20 mA. Failure to heed this restriction can cause degradation or possible destruction of the internal switch contact.

Similar to the mechanical potentiometer, the resistance of the digital POT between the wiper W and terminal A also produces a digitally controlled complementary resistance R_{WA} . When these terminals are used, the B terminal can be opened. Setting the resistance value for R_{WA} starts at a maximum value of resistance and decreases as the data loaded in the latch increases in value. The general equation for this operation is

$$R_{WA}(D) = \frac{256 - D}{256} R_{AB} + R_W \quad (\text{eq. 2})$$

For $R_{AB} = 100 \text{ k}\Omega$ and the B terminal open circuited, the following output resistance R_{WA} will be set for the indicated Wiper register codes.

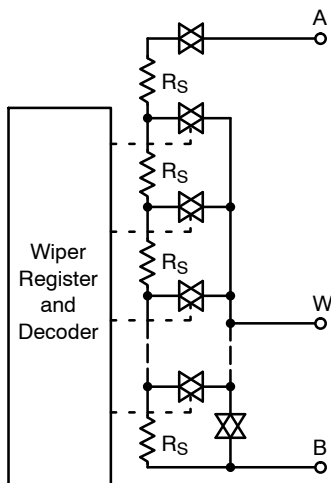

Figure 14. CAT5172 Equivalent Digital POT Circuit

CAT5172

Table 8. CODES AND CORRESPONDING R_{WA} RESISTANCE FOR $R_{AB} = 100\text{ k}\Omega$, $V_{DD} = 5\text{ V}$

D (Dec.)	R_{WA} (Ω)	Output State
255	441	Full Scale
128	50,050	Midscale
1	99,659	1 LSB
0	100,050	Zero Scale

Typical device to device resistance matching is lot dependent and may vary by up to $\pm 20\%$.

SPI Compatible 3-wire Serial Bus

Control of CAT5172 is through a 3-wire SPI compatible digital interface (SDI, \overline{CS} , and CLK).

The CLK input is rising-edge sensitive and requires crisp transitions to avoid clocking incorrect data into the serial input register. When \overline{CS} is low, the clock loads data into the serial register on each positive clock edge (Figure 1). Each 8-bit serial word must be loaded starting with the MSB. The format of the word is shown in Table 6.

Data loaded into CAT5172's 8-bit serial input register is transferred to the internal Wiper register when the \overline{CS} line returns to logic high. Extra MSB bits are ignored.

ESD Protection

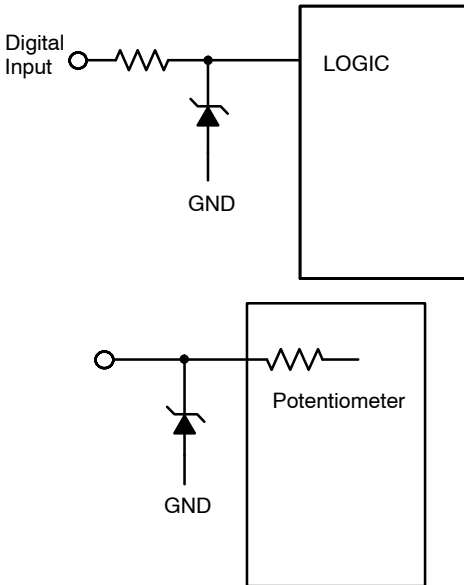

Figure 15. ESD Protection Networks

Terminal Voltage Operating Range

The CAT5172 V_{DD} and GND power supply define the limits for proper 3-terminal digital potentiometer operation. Signals or potentials applied to terminals A, B or the wiper must remain inside the span of V_{DD} and GND. Signals which attempt to go outside these boundaries will be clamped by the internal forward biased diodes.

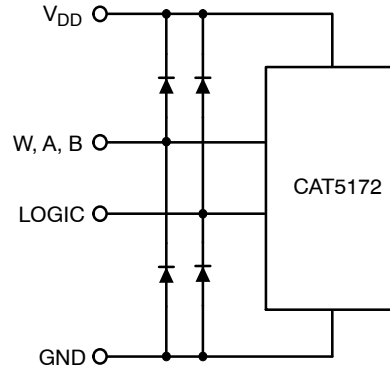

Figure 16.

Power-up Sequence

Because ESD protection diodes limit the voltage compliance at terminals A, B, and W (see Figure 15), it is recommended that V_{DD}/GND be powered before applying any voltage to terminals A, B, and W. The ideal power-up sequence is: GND, V_{DD} , digital inputs, and then $V_{A/B/W}$. The order of powering V_A , V_B , V_W , and the digital inputs is not important as long as they are powered after V_{DD}/GND .

Power Supply Bypassing

Good design practice employs compact, minimum lead length layout design. Leads should be as direct as possible. It is also recommended to bypass the power supplies with quality low ESR Ceramic chip capacitors of $0.01\ \mu\text{F}$ to $0.1\ \mu\text{F}$. Low ESR $1\ \mu\text{F}$ to $10\ \mu\text{F}$ tantalum or electrolytic capacitors can also be applied at the supplies to suppress transient disturbances and low frequency ripple. As a further precaution digital ground should be joined remotely to the analog ground at one point to minimize the ground bounce.

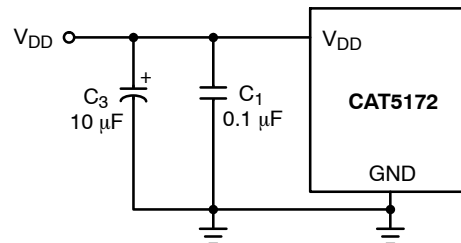

Figure 17. Power Supply Bypassing

MECHANICAL CASE OUTLINE

PACKAGE DIMENSIONS

ON Semiconductor®



SOT-23, 8 Lead
CASE 527AK-01
ISSUE A

DATE 18 MAR 2009

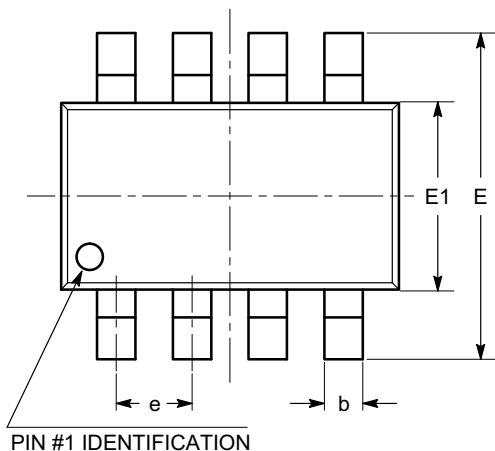

TOP VIEW

SYMBOL	MIN	NOM	MAX
A	0.90		1.45
A1	0.00		0.15
A2	0.90	1.10	1.30
A3	0.60		0.80
b	0.28		0.38
c	0.08		0.22
D	2.90 BSC		
E	2.80 BSC		
E1	1.60 BSC		
e	0.65 BSC		
L	0.30	0.45	0.60
L1	0.60 REF		
L2	0.25 REF		
θ	0°		8°

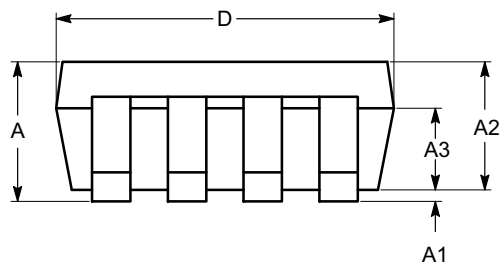

SIDE VIEW

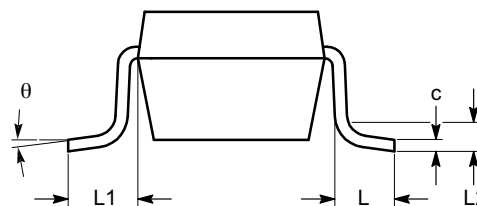

END VIEW

Notes:

- (1) All dimensions in millimeters. Angles in degrees.
- (2) Complies with JEDEC standard MO-178.

DOCUMENT NUMBER:	98AON34327E	Electronic versions are uncontrolled except when accessed directly from the Document Repository. Printed versions are uncontrolled except when stamped "CONTROLLED COPY" in red.
DESCRIPTION:	SOT-23, 8 LEAD	PAGE 1 OF 1

ON Semiconductor and are trademarks of Semiconductor Components Industries, LLC dba ON Semiconductor or its subsidiaries in the United States and/or other countries. ON Semiconductor reserves the right to make changes without further notice to any products herein. ON Semiconductor makes no warranty, representation or guarantee regarding the suitability of its products for any particular purpose, nor does ON Semiconductor assume any liability arising out of the application or use of any product or circuit, and specifically disclaims any and all liability, including without limitation special, consequential or incidental damages. ON Semiconductor does not convey any license under its patent rights nor the rights of others.

onsemi, **Onsemi**, and other names, marks, and brands are registered and/or common law trademarks of Semiconductor Components Industries, LLC dba "**onsemi**" or its affiliates and/or subsidiaries in the United States and/or other countries. **onsemi** owns the rights to a number of patents, trademarks, copyrights, trade secrets, and other intellectual property. A listing of **onsemi**'s product/patent coverage may be accessed at www.onsemi.com/site/pdf/Patent-Marking.pdf. **onsemi** reserves the right to make changes at any time to any products or information herein, without notice. The information herein is provided "as-is" and **onsemi** makes no warranty, representation or guarantee regarding the accuracy of the information, product features, availability, functionality, or suitability of its products for any particular purpose, nor does **onsemi** assume any liability arising out of the application or use of any product or circuit, and specifically disclaims any and all liability, including without limitation special, consequential or incidental damages. Buyer is responsible for its products and applications using **onsemi** products, including compliance with all laws, regulations and safety requirements or standards, regardless of any support or applications information provided by **onsemi**. "Typical" parameters which may be provided in **onsemi** data sheets and/or specifications can and do vary in different applications and actual performance may vary over time. All operating parameters, including "Typicals" must be validated for each customer application by customer's technical experts. **onsemi** does not convey any license under any of its intellectual property rights nor the rights of others. **onsemi** products are not designed, intended, or authorized for use as a critical component in life support systems or any FDA Class 3 medical devices or medical devices with a same or similar classification in a foreign jurisdiction or any devices intended for implantation in the human body. Should Buyer purchase or use **onsemi** products for any such unintended or unauthorized application, Buyer shall indemnify and hold **onsemi** and its officers, employees, subsidiaries, affiliates, and distributors harmless against all claims, costs, damages, and expenses, and reasonable attorney fees arising out of, directly or indirectly, any claim of personal injury or death associated with such unintended or unauthorized use, even if such claim alleges that **onsemi** was negligent regarding the design or manufacture of the part. **onsemi** is an Equal Opportunity/Affirmative Action Employer. This literature is subject to all applicable copyright laws and is not for resale in any manner.

ADDITIONAL INFORMATION

TECHNICAL PUBLICATIONS:

Technical Library: www.onsemi.com/design/resources/technical-documentation
onsemi Website: www.onsemi.com

ONLINE SUPPORT: www.onsemi.com/support

For additional information, please contact your local Sales Representative at www.onsemi.com/support/sales