

MOSFET – Power, N-Channel, Dual EFCP

12 V, 6 A, 29.5 mΩ

EFC4627R

Features

- 2.5 V Drive
- Protection Diode In
- Common–Drain Type
- This Device is Pb–Free, Halogen Free/BFR Free and is RoHS Compliant

Applications

- Lithium–ion Battery Charging and Discharging Switch

Specifications

ABSOLUTE MAXIMUM RATINGS (T_A = 25°C)

Parameter	Symbol	Conditions	Value	Unit
Source to Source Voltage	V _{SSS}		12	V
Gate to Source Voltage	V _{GSS}		±10	V
Source Current (DC)	I _S		6	A
Source Current (Pulse)	I _{SP}	PW ≤ 10 μs, Duty Cycle ≤ 1%	60	A
Total Dissipation	P _T	When mounted on ceramic substrate (5000 mm ² x 0.8 mm)	1.4	W
Junction Temperature	T _J		150	°C
Storage Temperature	T _{stg}		- 55 to +150	°C

Stresses exceeding those listed in the Maximum Ratings table may damage the device. If any of these limits are exceeded, device functionality should not be assumed, damage may occur and reliability may be affected.

THERMAL RESISTANCE RATINGS

Parameter	Symbol	Value	Unit
Junction to Ambient When mounted on ceramic substrate (5000 mm ² x 0.8 mm)	R _{θJA}	84	V

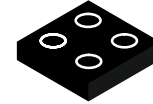

CSP4 1.01x1.01
CASE 568AK

MARKING DIAGRAM

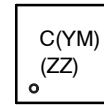

- C = Specific Device Code
Y = Year of Production
M = Assembly Operation Month
ZZ = Assembly Lot Number

ELECTRICAL CONNECTION

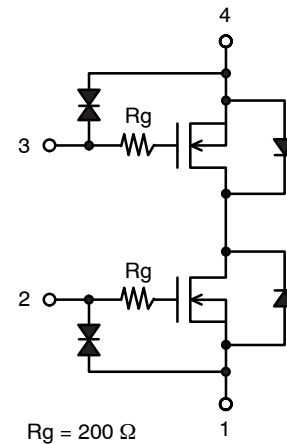

ORDERING INFORMATION

Device	Package	Shipping†
EFC4627R–TR	CSP4 (Pb–Free and Halogen Free)	8000 / Tape & Reel

†For information on tape and reel specifications, including part orientation and tape sizes, please refer to our Tape and Reel Packaging Specifications Brochure, [BRD8011/D](#).

ELECTRICAL CHARACTERISTICS ($T_A = 25^\circ\text{C}$)

Parameter	Symbol	Conditions	Min	Typ	Max	Unit	
Source to Source Breakdown Voltage	$V_{(BR)SSS}$	$I_S = 1\text{ mA}, V_{GS} = 0\text{ V}$	Test Circuit 1	12	-	-	V
Zero-Gate Voltage Source Current	I_{SSS}	$V_{SS} = 10\text{ V}, V_{GS} = 0\text{ V}$	Test Circuit 1	-	-	1	μA
Gate to Source Leakage Current	I_{GSS}	$V_{GS} = \pm 8\text{ V}, V_{SS} = 0\text{ V}$	Test Circuit 2	-	-	± 1	μA
Gate Threshold Voltage	$V_{GS(th)}$	$V_{SS} = 6\text{ V}, I_S = 1\text{ mA}$	Test Circuit 3	0.5	-	1.3	V
Forward Transconductance	g_{FS}	$V_{SS} = 6\text{ V}, I_S = 2\text{ A}$	Test Circuit 4	-	4.8	-	S
Static Source to Source On-State Resistance	$R_{SS(on)1}$	$I_S = 2\text{ A}, V_{GS} = 4.5\text{ V}$	Test Circuit 5	18.5	23.9	29.5	$\text{m}\Omega$
	$R_{SS(on)2}$	$I_S = 2\text{ A}, V_{GS} = 4.0\text{ V}$	Test Circuit 5	19.7	25.4	31.3	$\text{m}\Omega$
	$R_{SS(on)3}$	$I_S = 2\text{ A}, V_{GS} = 3.8\text{ V}$	Test Circuit 5	20.3	26.1	32.3	$\text{m}\Omega$
	$R_{SS(on)4}$	$I_S = 2\text{ A}, V_{GS} = 3.1\text{ V}$	Test Circuit 5	23.5	30.3	39.0	$\text{m}\Omega$
	$R_{SS(on)5}$	$I_S = 2\text{ A}, V_{GS} = 2.5\text{ V}$	Test Circuit 5	29.3	37.7	50.5	$\text{m}\Omega$
Turn-On Delay Time	$t_d(on)$	$V_{SS} = 6\text{ V}, V_{GS} = 4.5\text{ V}, I_S = 2\text{ A}$	Test Circuit 6	-	75	-	ns
Rise Time	t_r			-	740	-	ns
Turn-Off Delay Time	$t_d(off)$			-	2340	-	ns
Fall Time	t_f			-	2320	-	ns
Total Gate Charge	Qg	$V_{SS} = 6\text{ V}, V_{GS} = 4.5\text{ V}, I_S = 6\text{ A}$	Test Circuit 7	-	13.4	-	nC
Forward Source to Source Voltage	$V_{F(S-S)}$	$I_S = 3\text{ A}, V_{GS} = 0\text{ V}$	Test Circuit 8	-	0.76	-	V

Product parametric performance is indicated in the Electrical Characteristics for the listed test conditions, unless otherwise noted. Product performance may not be indicated by the Electrical Characteristics if operated under different conditions.

Test Circuits are Example of Measuring FET1 Side.

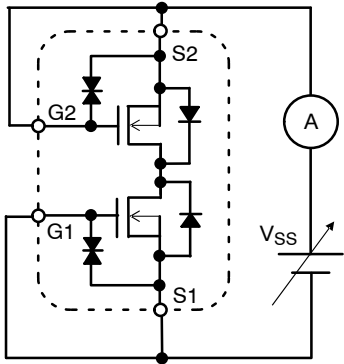

Figure 1. Test Circuit 1 - I_{SSS}

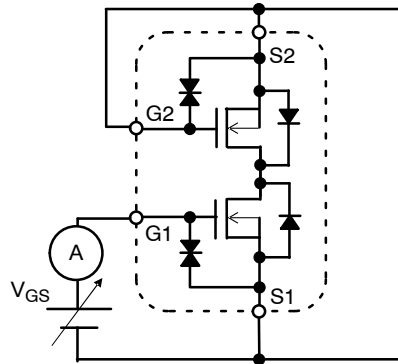

Figure 2. Test Circuit 2 - I_{GSS}

When FET1 is measured, Gate and Source of FET2 are short-circuited.

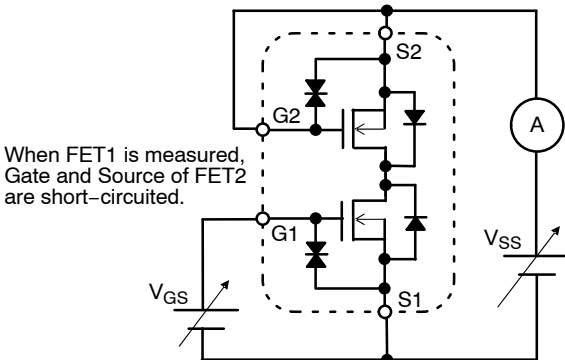

Figure 3. Test Circuit 3 - $V_{GS(th)}$

When FET1 is measured, Gate and Source of FET2 are short-circuited.

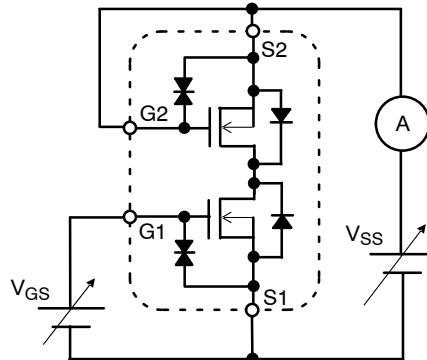

Figure 4. Test Circuit 4 - g_{FS}

When FET1 is measured, Gate and Source of FET2 are short-circuited.

TEST CIRCUITS (continued)

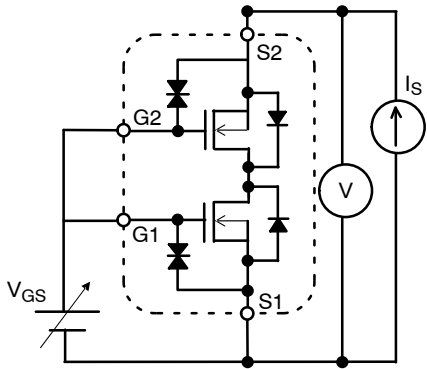

Figure 5. Test Circuit 5 - $R_{SS}(on)$

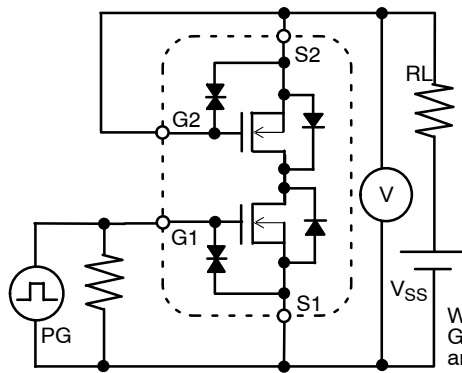

Figure 6. Test Circuit 6 - $t_d(on)$, t_r , $t_d(off)$, t_f

When FET1 is measured, Gate and Source of FET2 are short-circuited.

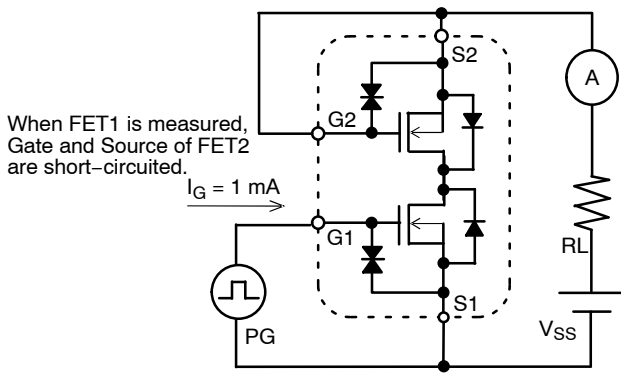

Figure 7. Test Circuit 7 - Q_g

When FET1 is measured, Gate and Source of FET2 are short-circuited.

$I_G = 1 \text{ mA}$

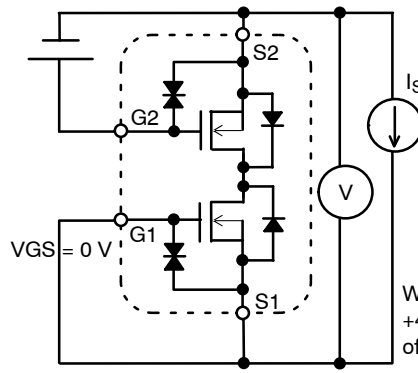

Figure 8. Test Circuit 8 - $V_{F(S-S)}$

When FET1 is measured, +4.5 V is added to V_{GS} of FET2.

NOTE: When FET2 is measured, the position of FET1 and FET2 is switched.

TYPICAL CHARACTERISTICS

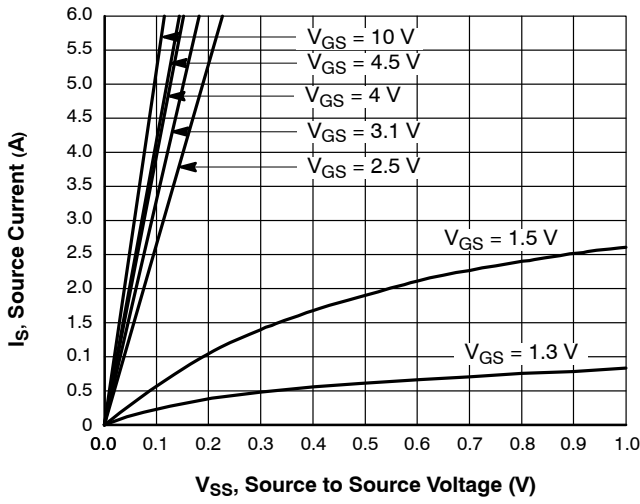

Figure 9. $I_S - V_{SS}$

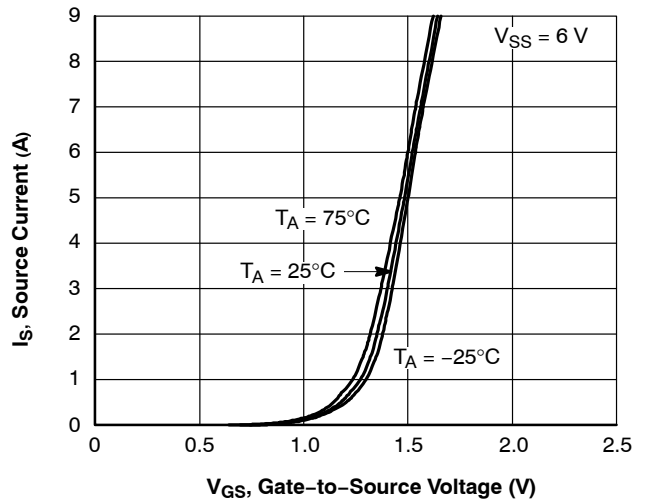

Figure 10. $I_S - V_{GS(th)}$

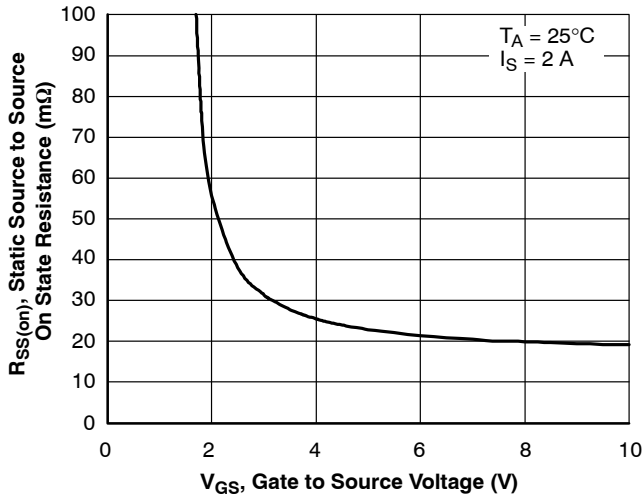

Figure 11. $R_{SS(on)} - V_{GS}$

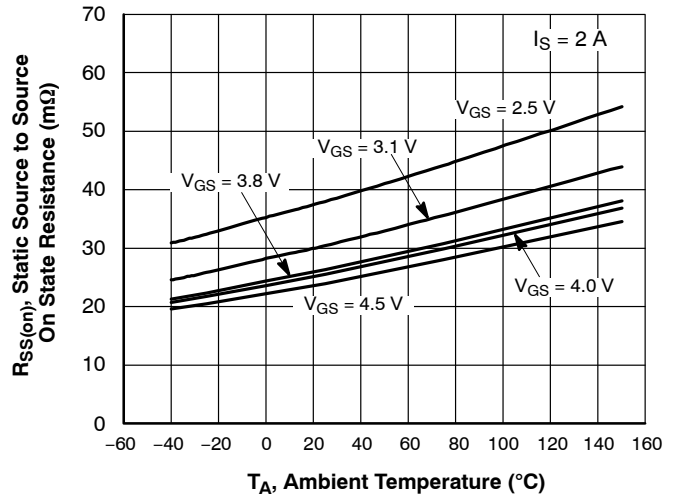

Figure 12. $R_{SS(on)} - T_A$

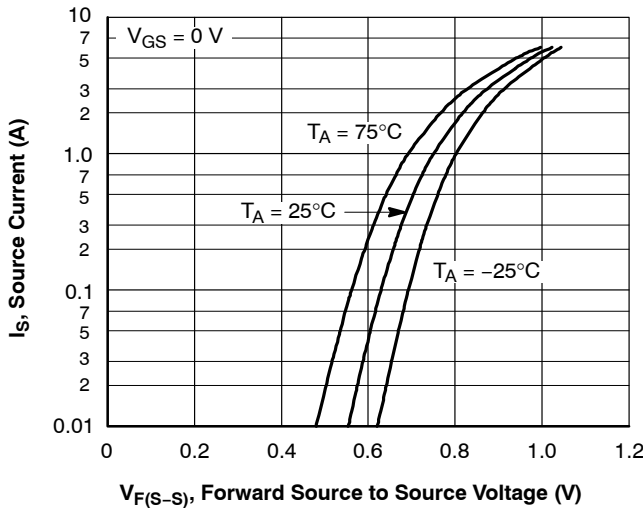

Figure 13. $I_S - V_{F(S-S)}$

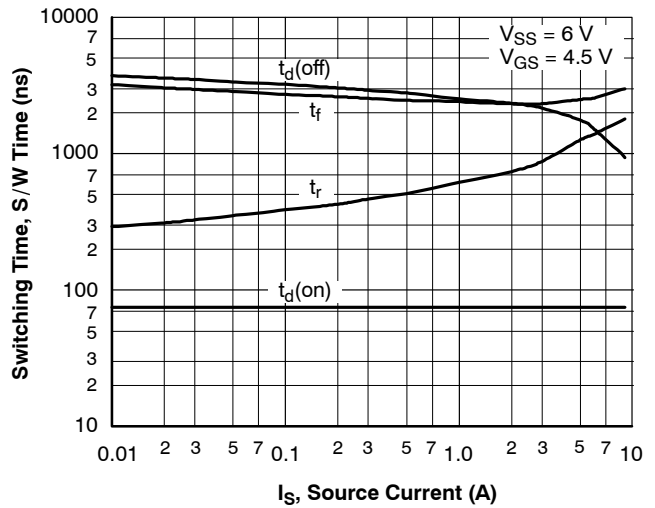

Figure 14. S/W Time - I_S

TYPICAL CHARACTERISTICS (continued)

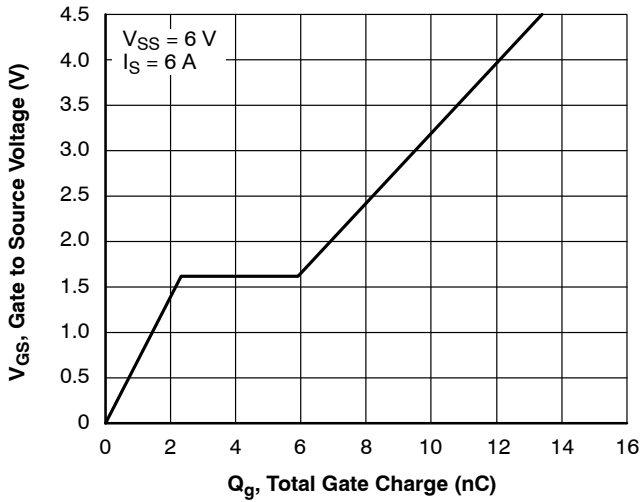

Figure 15. $V_{GS} - Q_g$

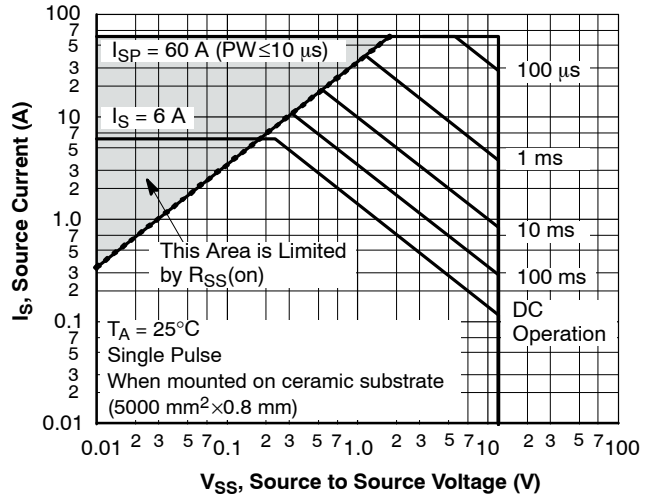

Figure 16. SOA

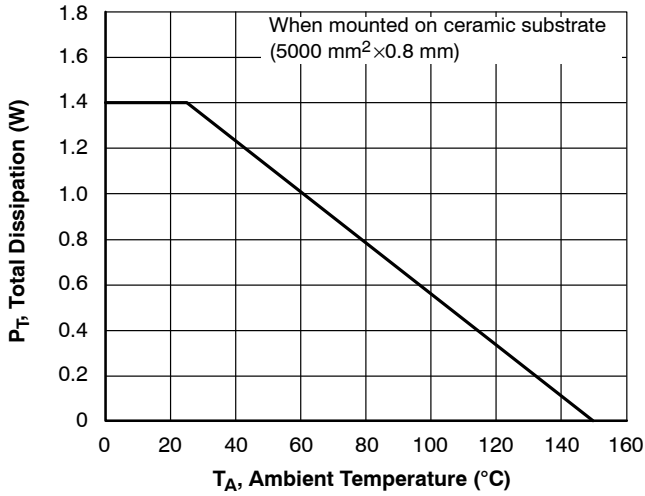

Figure 17. $P_T - T_A$

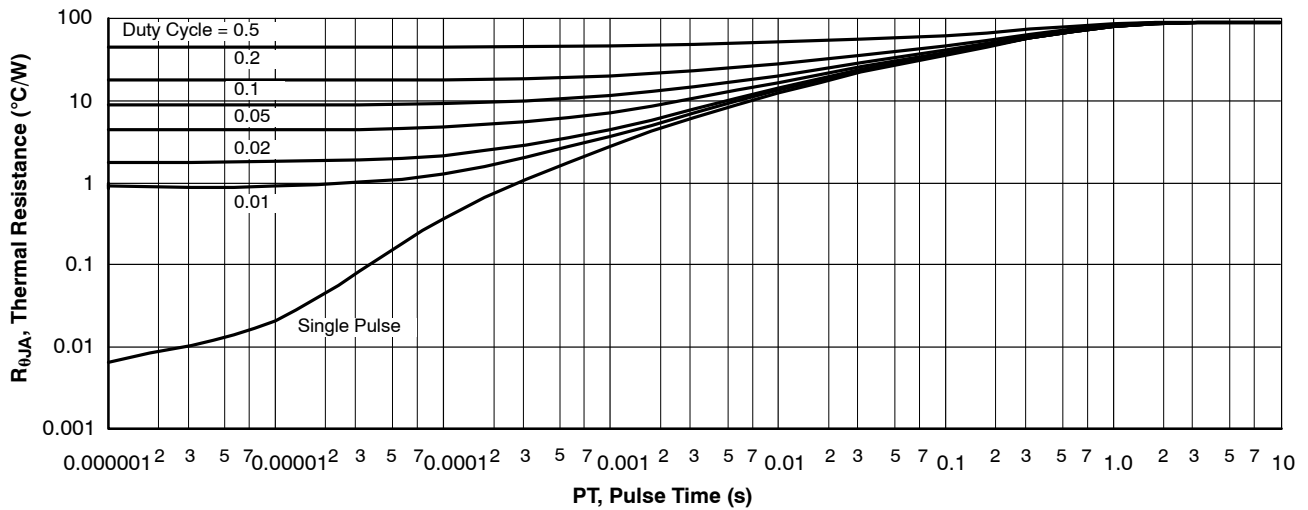

Figure 18. $R_{\theta JA} - \text{Pulse Time}$

EFC4627R

PACKAGE DIMENSION

EFC4627R-TR

(Unit: mm)

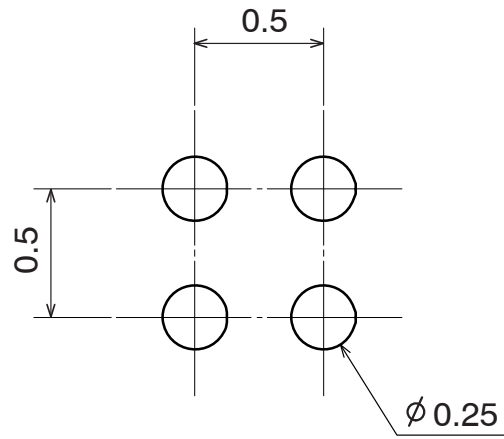
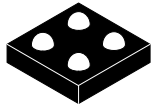

Figure 19. Recommended Soldering Footprint

Note on usage: Since the EFC4627R is a MOSFET product, please avoid using this device in the vicinity of highly charged objects.

MECHANICAL CASE OUTLINE
PACKAGE DIMENSIONS



WLCSP4, 1.01x1.01x0.22, 0.50P
CASE 568AK
ISSUE B

DATE 14 NOV 2023

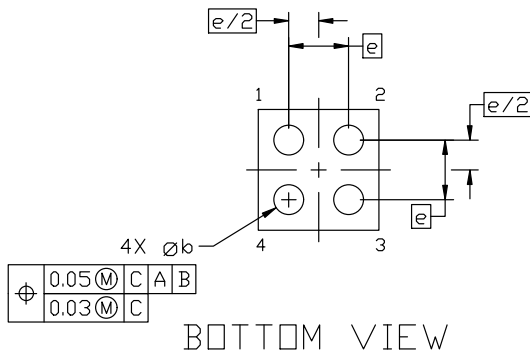
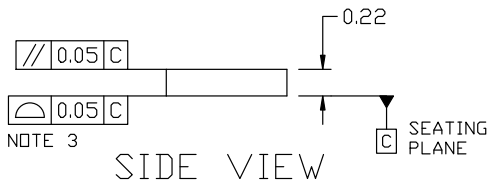
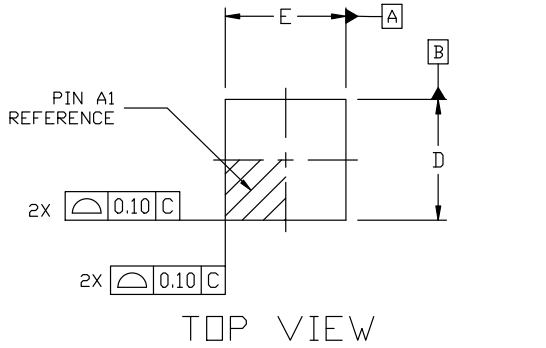

NOTES:

1. DIMENSIONING AND TOLERANCING PER ASME Y14.5M, 2018.
2. CONTROLLING DIMENSION: MILLIMETERS
3. COPLANARITY APPLIES TO THE SPHERICAL CROWNS OF THE SOLDER BALLS.

DIM	MILLIMETERS		
	MIN.	NOM.	MAX.
A	---	---	0.22
b	0.22	0.25	0.28
D	0.99	1.01	0.11
E	0.99	1.01	0.11
e	0.50 BSC		

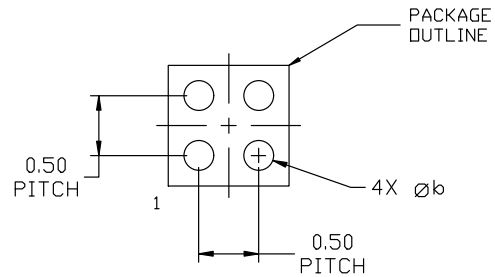

RECOMMENDED MOUNTING FOOTPRINT

*FOR ADDITIONAL INFORMATION ON OUR PB-FREE STRATEGY AND SOLDERING DETAILS, PLEASE DOWNLOAD THE ON SEMICONDUCTOR SOLDERING AND MOUNTING TECHNIQUES REFERENCES MANUAL, SOLDERRM/D.

DOCUMENT NUMBER:	98AON78060F	Electronic versions are uncontrolled except when accessed directly from the Document Repository. Printed versions are uncontrolled except when stamped "CONTROLLED COPY" in red.
DESCRIPTION:	WLCSP4, 1.01x1.01x0.22, 0.50P	PAGE 1 OF 1

onsemi and ONSEMI are trademarks of Semiconductor Components Industries, LLC dba onsemi or its subsidiaries in the United States and/or other countries. onsemi reserves the right to make changes without further notice to any products herein. onsemi makes no warranty, representation or guarantee regarding the suitability of its products for any particular purpose, nor does onsemi assume any liability arising out of the application or use of any product or circuit, and specifically disclaims any and all liability, including without limitation special, consequential or incidental damages. onsemi does not convey any license under its patent rights nor the rights of others.

onsemi, **Onsemi**, and other names, marks, and brands are registered and/or common law trademarks of Semiconductor Components Industries, LLC dba "**onsemi**" or its affiliates and/or subsidiaries in the United States and/or other countries. **onsemi** owns the rights to a number of patents, trademarks, copyrights, trade secrets, and other intellectual property. A listing of **onsemi**'s product/patent coverage may be accessed at www.onsemi.com/site/pdf/Patent-Marking.pdf. **onsemi** reserves the right to make changes at any time to any products or information herein, without notice. The information herein is provided "as-is" and **onsemi** makes no warranty, representation or guarantee regarding the accuracy of the information, product features, availability, functionality, or suitability of its products for any particular purpose, nor does **onsemi** assume any liability arising out of the application or use of any product or circuit, and specifically disclaims any and all liability, including without limitation special, consequential or incidental damages. Buyer is responsible for its products and applications using **onsemi** products, including compliance with all laws, regulations and safety requirements or standards, regardless of any support or applications information provided by **onsemi**. "Typical" parameters which may be provided in **onsemi** data sheets and/or specifications can and do vary in different applications and actual performance may vary over time. All operating parameters, including "Typicals" must be validated for each customer application by customer's technical experts. **onsemi** does not convey any license under any of its intellectual property rights nor the rights of others. **onsemi** products are not designed, intended, or authorized for use as a critical component in life support systems or any FDA Class 3 medical devices or medical devices with a same or similar classification in a foreign jurisdiction or any devices intended for implantation in the human body. Should Buyer purchase or use **onsemi** products for any such unintended or unauthorized application, Buyer shall indemnify and hold **onsemi** and its officers, employees, subsidiaries, affiliates, and distributors harmless against all claims, costs, damages, and expenses, and reasonable attorney fees arising out of, directly or indirectly, any claim of personal injury or death associated with such unintended or unauthorized use, even if such claim alleges that **onsemi** was negligent regarding the design or manufacture of the part. **onsemi** is an Equal Opportunity/Affirmative Action Employer. This literature is subject to all applicable copyright laws and is not for resale in any manner.

ADDITIONAL INFORMATION

TECHNICAL PUBLICATIONS:

Technical Library: www.onsemi.com/design/resources/technical-documentation
onsemi Website: www.onsemi.com

ONLINE SUPPORT: www.onsemi.com/support

For additional information, please contact your local Sales Representative at www.onsemi.com/support/sales