



Is Now Part of



**ON Semiconductor®**

To learn more about ON Semiconductor, please visit our website at  
[www.onsemi.com](http://www.onsemi.com)

Please note: As part of the Fairchild Semiconductor integration, some of the Fairchild orderable part numbers will need to change in order to meet ON Semiconductor's system requirements. Since the ON Semiconductor product management systems do not have the ability to manage part nomenclature that utilizes an underscore (\_), the underscore (\_) in the Fairchild part numbers will be changed to a dash (-). This document may contain device numbers with an underscore (\_). Please check the ON Semiconductor website to verify the updated device numbers. The most current and up-to-date ordering information can be found at [www.onsemi.com](http://www.onsemi.com). Please email any questions regarding the system integration to [Fairchild\\_questions@onsemi.com](mailto:Fairchild_questions@onsemi.com).

ON Semiconductor and the ON Semiconductor logo are trademarks of Semiconductor Components Industries, LLC dba ON Semiconductor or its subsidiaries in the United States and/or other countries. ON Semiconductor owns the rights to a number of patents, trademarks, copyrights, trade secrets, and other intellectual property. A listing of ON Semiconductor's product/patent coverage may be accessed at [www.onsemi.com/site/pdf/Patent-Marking.pdf](http://www.onsemi.com/site/pdf/Patent-Marking.pdf). ON Semiconductor reserves the right to make changes without further notice to any products herein. ON Semiconductor makes no warranty, representation or guarantee regarding the suitability of its products for any particular purpose, nor does ON Semiconductor assume any liability arising out of the application or use of any product or circuit, and specifically disclaims any and all liability, including without limitation special, consequential or incidental damages. Buyer is responsible for its products and applications using ON Semiconductor products, including compliance with all laws, regulations and safety requirements or standards, regardless of any support or applications information provided by ON Semiconductor. "Typical" parameters which may be provided in ON Semiconductor data sheets and/or specifications can and do vary in different applications and actual performance may vary over time. All operating parameters, including "Typicals" must be validated for each customer application by customer's technical experts. ON Semiconductor does not convey any license under its patent rights nor the rights of others. ON Semiconductor products are not designed, intended, or authorized for use as a critical component in life support systems or any FDA Class 3 medical devices or medical devices with a same or similar classification in a foreign jurisdiction or any devices intended for implantation in the human body. Should Buyer purchase or use ON Semiconductor products for any such unintended or unauthorized application, Buyer shall indemnify and hold ON Semiconductor and its officers, employees, subsidiaries, affiliates, and distributors harmless against all claims, costs, damages, and expenses, and reasonable attorney fees arising out of, directly or indirectly, any claim of personal injury or death associated with such unintended or unauthorized use, even if such claim alleges that ON Semiconductor was negligent regarding the design or manufacture of the part. ON Semiconductor is an Equal Opportunity/Affirmative Action Employer. This literature is subject to all applicable copyright laws and is not for resale in any manner.



November 2013

# FAN8060 1.2 MHz, 1 A Synchronous Step-Down DC/DC Regulator

## Features

- Current Mode Control
- Over 96% Efficient
- Selectable Continuous Output Current: 500 mA/1 A
- 2.5 V to 5.5 V Input Voltage Range
- Output Voltage as Low as 1.2 V
- 1.2 MHz Operating Frequency
- Less than 1  $\mu$ A Shutdown Current
- External Synchronization from 500 kHz to 2 MHz
- 100% Duty Cycle
- Synchronous Switching FET; no Schottky Diode Required
- Stable with Ceramic Capacitors
- Light Load Mode with Pulse Skipping
- External Compensation
- External Soft-Start
- Overload / Short-Circuit Protection
- Under-Voltage Lockout
- Thermal Shutdown
- 10-Lead 3x3 mm Green MLP Package

## Applications

- PDAs
- GPS Devices
- MP3 Players
- Mini PCI
- Digital Cameras
- Peripheral Ports
- DSP Core
- USB Devices
- PCMCIA
- Cable Modem
- Data Cards

## Description

The FAN8060 is a highly efficient, monolithic, current-mode, step-down synchronous regulator. It can provide 1 A continuous current from 2.5 V to 5.5 V input voltage. The output voltage can be adjusted from 1.2 V up to the input voltage with an external voltage divider.

External compensation and soft-start allow for design optimization and flexibility. High-frequency operation allows for all-ceramic solutions and small footprints. In addition, a user-selectable current limit provides protection against output overload and short circuit.

FAN8060 features pulse skipping to achieve higher efficiency during light load operation. 100% duty cycle capability enables power solutions to extend the drop out voltage.

Provision for external synchronization allows users to minimize input capacitors and manage EMI in solutions.

FAN8060 is available in a green, low profile, 10-Lead 3x3 mm MLP package.

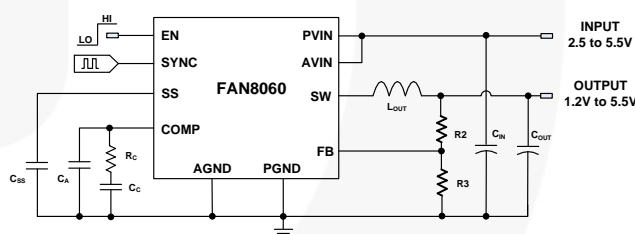

Figure 1. Typical Application Circuit

## Ordering Information

Part Number	Operating Temperature Range	Package	Packing Method
FAN8060EMPX	-40 to +85°C	10-Pin, 3x3 mm Molded Leadless Package (MLP)	Tape & Reel

For Fairchild's definition of "green" Eco Status, please visit: [http://www.fairchildsemi.com/company/green/rohs\\_green.html](http://www.fairchildsemi.com/company/green/rohs_green.html).

## Pin Configuration

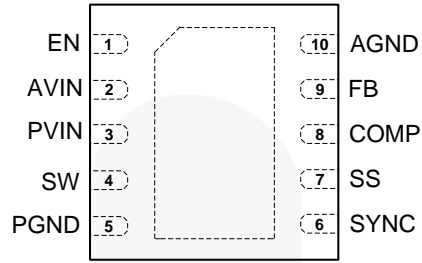

Figure 2. Pin Configuration (Top View)

### Note:

1. Connect exposed PAD to AGND

## Pin Definitions

Pin	Name	Function
1	EN	<b>Enable.</b> Enables operation when pulled to logic HIGH.
2	AVIN	<b>Analog Input Voltage.</b> All internal control circuits are connected to this supply.
3	PVIN	<b>Power Input Voltage.</b> Power stage supply voltage.
4	SW	<b>Switching Node.</b> The drains of both PMOS and NMOS.
5	PGND	<b>Power Ground.</b> Power return and source of the power NMOS
6	SYNC	<b>Synchronization.</b> Use this pin to synchronize the part to an external clock. This pin also controls current limit threshold. Tie to ground for 1.0 A or tie to $V_{IN}$ for 0.5 A continuous load current. When an external clock is applied, the default current setting is 1 A. This pin has a pull-down resistor of 450 K $\Omega$ .
7	SS	<b>Soft-Start.</b> A capacitor connected between this pin and AGND can set soft-start time.
8	COMP	<b>Compensation.</b> Error amplifier output. Connect the external compensation network between this pin and AGND.
9	FB	<b>Output Voltage Feedback.</b> Connect through a resistor divider to set the output voltage.
10	AGND	<b>Analog Ground.</b> Ground return for all internal control circuits.

## Absolute Maximum Ratings

Stresses exceeding the absolute maximum ratings may damage the device. The device may not function or be operable above the recommended operating conditions and stressing the parts to these levels is not recommended. In addition, extended exposure to stresses above the recommended operating conditions may affect device reliability. The absolute maximum ratings are stress ratings only. All voltage values, except differential voltages, are given with respect to the network ground terminal. Stress beyond those listed under Absolute Maximum Ratings may cause permanent damage to the device.

Symbols	Parameter	Min.	Max.	Unit
V <sub>PVIN</sub>	PVIN (AGND=PGND)	-0.3	6.0	V
V <sub>AVIN</sub>	AVIN (AGND=PGND)	-0.3	6.0	V
V <sub>SW</sub>	Switch Voltage, SW to GND	-0.3	V <sub>IN</sub> + 0.3 or 6.0	V
	All other pins except COMP	-0.3	6.0	V
T <sub>STG</sub>	Storage Temperature	-65	+150	°C
T <sub>J</sub>	Junction Temperature	-40	+125	°C
ESD	Electrostatic Discharge Protection	Human Body Model, JESD22-A114	2.0	kV
		Charged Device Model, JESD22-C101	2.5	

**Note:**

- COMP pin has an internal clamp to 1.5 V.

## Recommended Operating Conditions

The Recommended Operating Conditions table defines the conditions for actual device operation. Recommended operating conditions are specified to ensure optimal performance to the datasheet specifications. Fairchild does not recommend exceeding them or designing to Absolute Maximum Ratings.

Symbol	Parameter	Min.	Max.	Unit
V <sub>IN</sub>	Supply Voltage	2.5	5.5	V
T <sub>A</sub>	Ambient Operating Temperature	-40	+85	°C

## Thermal Information

Symbol	Parameter	Min.	Typ.	Max.	Units
T <sub>STG</sub>	Storage Temperature	-65		+150	°C
T <sub>L</sub>	Lead Soldering Temperature, 30 Seconds			+300	°C
θ <sub>JA</sub>	Thermal Resistance: Junction-to-Ambient		49		°C/W
θ <sub>JC</sub>	Thermal Resistance: Junction-to-Case <sup>(3)</sup>		8		°C/W
P <sub>D</sub>	Total Power Dissipation in the package, T <sub>A</sub> =25°C <sup>(3)</sup>			1.3	W

**Note:**

- Typical thermal resistance when mounted on a four-layer PCB. Actual results are dependent upon mounting method and surface related to the design.

## Electrical Characteristics

$V_{IN}=5.0$  V,  $V_{OUT}=2.5$  V,  $C_{OUT}=10$   $\mu$ F,  $C_{IN}=10$   $\mu$ F, over operating range, unless otherwise noted.

Symbol	Parameter	Conditions	Min.	Typ.	Max.	Units
<b>Basic Operation</b>						
$V_{IN}$	$V_{IN}$ Operating Voltage	$A_{VIN}=P_{VIN}$	2.5		5.5	V
$I_Q$	Quiescent Current	$V_{EN}=5$ V, $V_{SS}=0$ V	250	371	500	$\mu$ A
$I_{SD}$	Shutdown Current	$V_{EN}=0$ V		0.34	0.60	$\mu$ A
$V_{UVLO}$	$V_{IN}$ Under-Voltage Lockout	Rising $V_{IN}$	2.10	2.19	2.25	V
$V_{UVLOHYS}$	$V_{IN}$ Under-Voltage Lockout Hysteresis			70		mV
$V_{ENH}$	Enable High Input Voltage			1.70	2.00	V
$V_{ENL}$	Enable Low Input Voltage		0.80	1.22		V
$R_{ONPMOS}$	PMOS On Resistance <sup>(4)</sup>	$V_{IN}=5$ V		200		m $\Omega$
		$V_{IN}=3.3$ V		300		
$R_{ONNMOS}$	NMOS On Resistance <sup>(4)</sup>	$V_{IN}=5$ V		200		m $\Omega$
		$V_{IN}=3.3$ V		300		
$I_{LIM}$	P-Channel Current Limit $V_{FB}=0.7$ V, $V_{IN}=5$ V, 100% Duty Cycle	$V_{SYNC}=0$ V		1.2		A
		$V_{SYNC}=V_{IN}$		0.6		
$f_{OSC}$	Oscillator Frequency	$T_A=25^\circ$ C	1.105	1.210	1.350	MHz
$V_{SYNC}$	SYNC Threshold	Rising Edge		$V_{IN}/2$		V
$f_{SYNC}$	Synchronization Frequency	$V_{SYNC}$ =Square Wave	500		2000	KHz
$t_{SYNC}$	Minimum SYNC Pulse Width	$V_{SYNC}$ On Time		100		ns
$I_{AMP}$	Error Amplifier	Sink/Source Current	30	45	60	$\mu$ A
		$G_{EA}$ <sup>(4)</sup>	700	1000	1400	$\mu$ A/V
		$A_{VEA}$ <sup>(4)</sup>		550		V/V
$G_{CS}$	Current Sense Gain <sup>(4)</sup>			3		A/V
$V_{REF}$	Reference Voltage for Temperature Co-efficient, see Figure 12	Measured at FB Pin $T_A=25^\circ$ C	1.181	1.205	1.229	V
$I_{FB}$	FB Bias Current	$T_A=25^\circ$ C	-0.10	-0.06	0	$\mu$ A
$I_{SS}$	Soft-Start Current		-5.5	-4.5	-3.5	$\mu$ A
<b>Protections</b>						
$T_{OTP}$	Over-Temperature Threshold <sup>(4)</sup>			+165		$^\circ$ C
$T_{HYS}$	Over-Temperature Hysteresis			+20		$^\circ$ C

### Note:

4. Guaranteed by design and characterization; not production tested.

### Functional Block Diagram

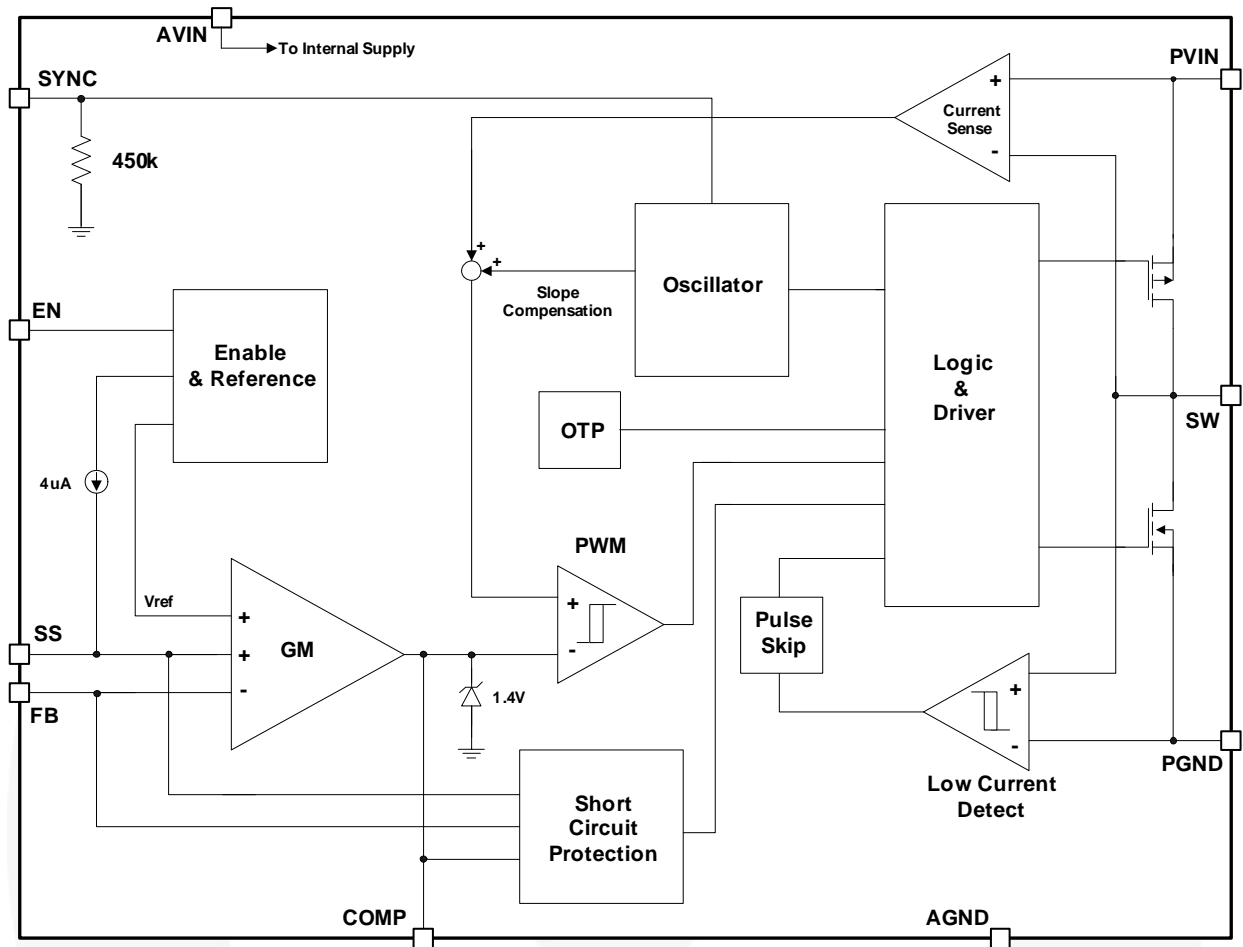

Figure 3. Functional Block Diagram

## Operation Description

The FAN8060 is a step-down converter operating in current-mode PWM architecture with a typical switching frequency of 1.2 MHz. At the beginning of each clock cycle, the P-channel transistor is turned on. The current in the inductor ramps up and is sensed via an internal circuit. The P-channel switch is turned off when the sensed current causes the PWM comparator to trip, which is when the output voltage is in regulation or when the inductor current reaches the current limit (set internally to 1.2 A, typically). After a minimum dead time to prevent shoot-through current, the N-channel transistor is turned on and the current ramps down. As the clock cycle is completed, the N-channel switch is turned off and the next clock cycle starts.

### Light Load Operation

As the output load reduces, the current in the inductor during off time is sensed across the low side MOSFET. When the current reverses direction, the low-side MOSFET is turned off and the high-side MOSFET is not turned on until the output is out of regulation.

### 100% Duty Cycle Operation

As the input voltage approaches the output voltage, the controller starts to increase the duty cycle to maintain output regulation until duty cycle reaches 85%. The controller then transitions to a 100% duty cycle mode over several cycles to support the load. When the dropout condition is met, the converter turns the P-channel high side continuously on. In this mode, the output voltage is equal to the input voltage, minus the voltage drop across the P-channel MOSFET.

### Soft Start

When the input voltage on AVIN exceeds the UVLO threshold and EN is high, the circuit releases SS and enables the PWM regulator. A capacitor connected to the SS pin and AGND is charged by a 4  $\mu$ A internal current source, causing the voltage on the capacitor to rise. When this voltage reaches 1.2 V, the output is in regulation. The SS voltage continues to rise to AVIN. The time for the output to reach regulation is given by the following equation:

$$t(ms) = \frac{C_{SS}(nF)}{(4\mu A/1.2V)} \quad (1)$$

Output overload and short-circuit protection is active during soft-start. When the part is disabled, SS pin is pulled low internally.

### Overload & Short-Circuit Protection

FAN8060 employs cycle-by-cycle current limiting, which limits current by reducing duty cycle during overload. As the load increases beyond the limit, the output voltage starts to reduce, thereby reducing the FB voltage. When the FB node is half the reference voltage and the COMP node has reached maximum value, short-circuit protection is detected. At that time, both the SS pin and the COMP pin are pulled to ground until the inductor current crosses zero. At that point, both SS and COMP are released for the current to ramp up again. This continues until the short-circuit condition is released.

## Typical Performance Characteristics

$V_{IN}=5\text{ V}$ ,  $V_{OUT}=2.4\text{ V}$ ,  $L=3.3\text{ }\mu\text{H}$ ,  $C_{IN}=10\text{ }\mu\text{F}$ ,  $C_{OUT}=10\text{ }\mu\text{F}$ ,  $f_s=1.2\text{ MHz}$ ,  $T_A=25^\circ\text{C}$ , unless otherwise noted.

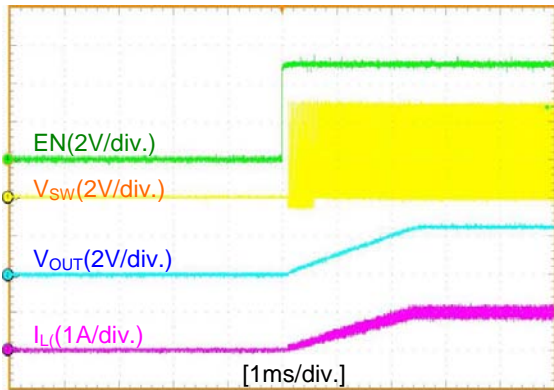

Figure 4. EN Startup with 1 A Load

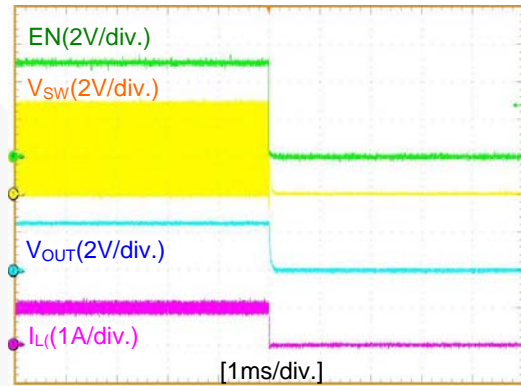

Figure 5. EN Turn off with 1 A Load

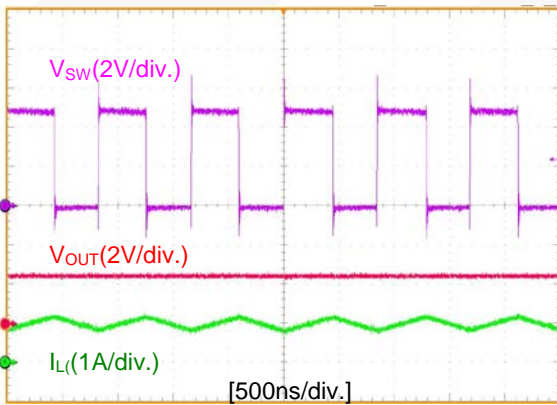

Figure 6. PWM Operation with 1 A Load

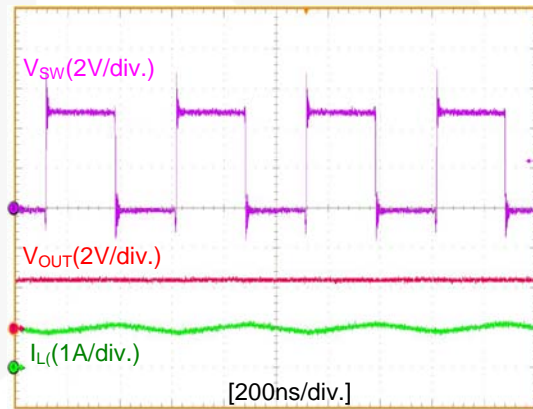

Figure 7. 2 MHz Sync Operation with 1 A Load

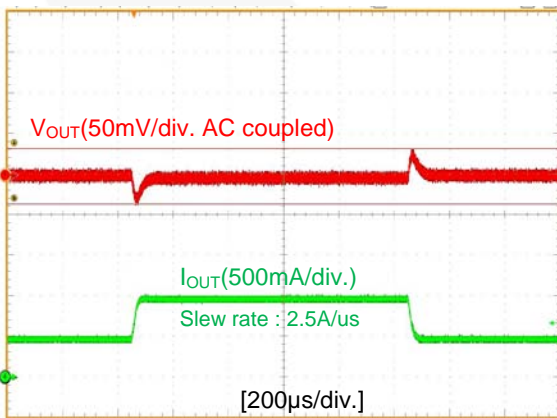

Figure 8. Load Transient Response(Step-up/down)

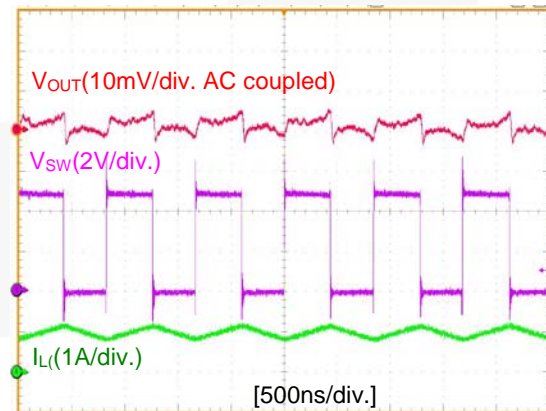

Figure 9. Output Voltage Ripple with 1 A Load



### Typical Performance Characteristics (Continued)

$V_{IN}=5\text{ V}$ ,  $V_{OUT}=2.4\text{ V}$ ,  $L=3.3\text{ }\mu\text{H}$ ,  $C_{IN}=10\text{ }\mu\text{F}$ ,  $C_{OUT}=10\text{ }\mu\text{F}$ ,  $f_s=1.2\text{ MHz}$ ,  $T_A=25^\circ\text{C}$ , unless otherwise noted.

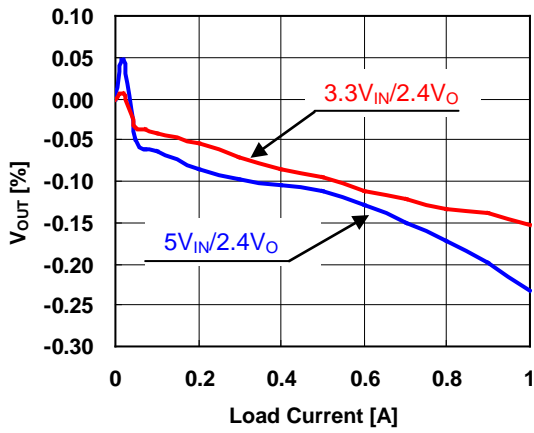

Figure 10. Normalized  $V_{OUT}$  vs. Load Current

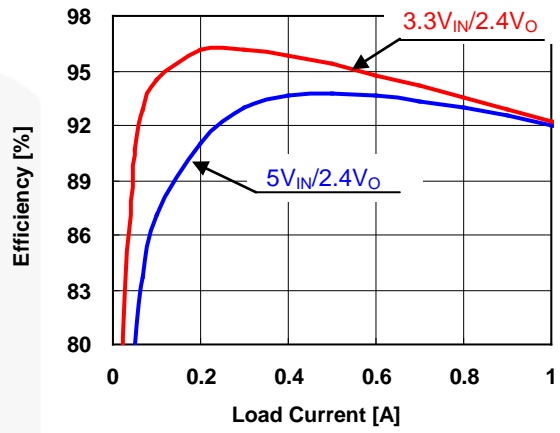

Figure 11. Efficiency vs. Load Current

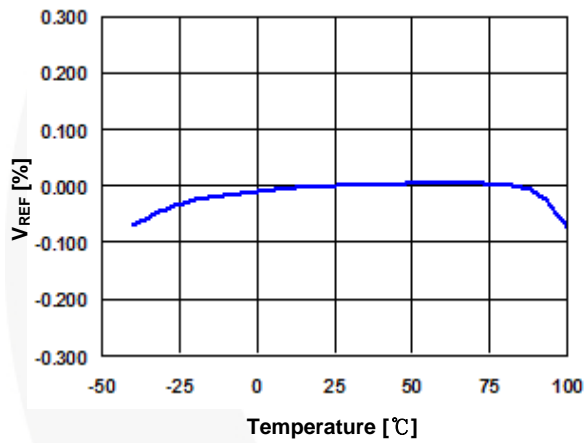

Figure 12. Normalized  $V_{REF}$  vs. Temperature

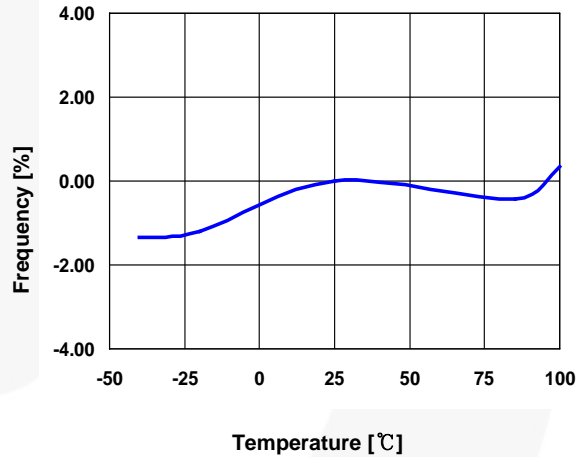

Figure 13. Normalized Oscillation Frequency vs. Temperature

## Applications Information

Refer to Figure 1 for reference designators.

### Output Voltage Setting

The output voltage of the FAN8060 can be set from 1.2 V to  $V_{IN}$  by an external resistor divider, given by the following equation:

$$V_{OUT} = 1.2 \left( 1 + \frac{R_2}{R_3} \right) \quad (2)$$

where,  $V_{OUT}$  equals the output voltage.

### Inductor Selection

Typically, the inductor value is chosen based on ripple current ( $\Delta I_L$ ), which is chosen between 10% and 35% of the maximum DC load. Regulator designs that require fast transient response use a higher ripple-current setting, while regulator designs that require higher efficiency keep ripple current on the low side and operate at a lower switching frequency.

For a given output voltage ripple requirement, L can be calculated by the following equation:

$$L \geq \frac{V_{OUT} \cdot (1-D)}{\Delta I_L \cdot f_S} \quad (3)$$

where;

D = Duty ratio ( $V_O/V_{IN}$ );

$f_S$  = Switching frequency; and

$\Delta I_L$  = Inductor ripple value, typically set to 10% - 35% of the maximum steady-state load current.

The inductor should have a low DCR to minimize the conduction losses and maximize efficiency. Some recommended inductors are suggested in Table 1:

**Table 1. Recommended Inductors (3.3  $\mu$ H)**

Size[mm2]	DCR	Part Number	Vendor
7x7x3	23 m $\Omega$	SLF7032T-3R3	TDK
5x5x2	60 m $\Omega$	LTF5022T-3R3	TDK
4x4x2	78 m $\Omega$	VLCF4020T-3R3	TDK
2.6x2.8x1.2	130 m $\Omega$	VLF3012AT-3R3	TDK

### Output Capacitor Selection

The output capacitor is selected based on the needs of the final application and its output ripple requirements. A larger output capacitor value reduces the output ripple voltage. The formula of output ripple  $\Delta V_{OUT}$  is:

$$\Delta V_{OUT} \cong \Delta I_L \left( ESR + \frac{1}{8 \cdot C_{OUT} \cdot f_S} \right) \quad (4)$$

where  $C_{OUT}$  is the output capacitor.

ESR is the equivalent series resistance of the output capacitor.

### Input Capacitor Selection

The input capacitor reduces the RMS current drawn from the input and switching noise from the device. The combined RMS current rating for the input capacitor should be greater than the value calculated by the following equation:

$$I_{RMS} = I_{OUTMAX} \cdot (\sqrt{D-D^2}) \quad (5)$$

where:

$I_{RMS}$  = RMS current of the input capacitor; and

$I_{OUTMAX}$  = Maximum output current.

Small, high value, inexpensive, lower-ESR ceramic capacitors are recommended; 10  $\mu$ F ceramic capacitors with X7R or X5R should be adequate for 1 A applications.

### Loop Compensation

The loop is compensated using a feedback network connected between COMP and AGND. Figure 14 shows a Type-2 compensation network used to stabilize the FAN8060.

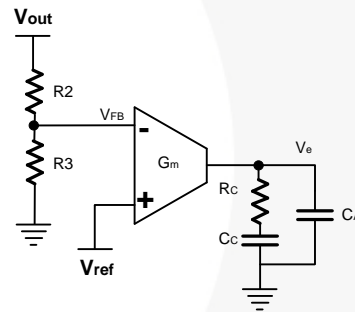

**Figure 14. Compensation Network**

The goal of the compensation design is to shape the frequency response of the converter to achieve high DC gain and fast transient, while maintaining loop stability. FAN8060 employs peak-current-mode control for easy use and fast transient response. Current mode control helps simplify the loop to a one-pole and one zero system.

The DC gain of the voltage feedback loop is given by:

$$A_{VDC} = R_L \cdot G_{CS} \cdot A_{VEA} \cdot \frac{V_{FB}}{V_{OUT}} \quad (6)$$

where:

$A_{VDC}$  = DC gain of the feedback loop;

$R_L$  = Load resistor value ( $V_{OUT}/I_{OUT}$ );

$G_{CS}$  = Current sense gain (3 A/V);

$A_{VEA}$  = Error amplifier voltage gain (550 V/V); and

$V_{FB}$  = Feedback threshold voltage (1.2 V).

The system pole is calculated by the equation:

$$f_{p1} = \frac{1}{2\pi \cdot C_{OUT} \cdot R_L} \quad (7)$$

The system zero is due to the output capacitor and its ESR. System zero is calculated by the equation:

$$f_{z1} = \frac{1}{2\pi \cdot C_{OUT} \cdot ESR} \quad (8)$$

The output characteristics of the error (G<sub>m</sub>) amplifier are controlled by a series capacitor and resistor network connected at the COMP pin to GND.

The pole is calculated by the following equation:

$$f_{p2} = \frac{G_{EA}}{2\pi \cdot C_C \cdot A_{VEA}} \quad (9)$$

where:

G<sub>EA</sub> = Error Amplifier Transconductance (1000 μA/V); and

C<sub>C</sub> = compensation capacitor.

Zero is due to the compensation capacitor (C<sub>C</sub>) and resistor (R<sub>C</sub>) calculated by the following equation:

$$f_{z2} = \frac{1}{2\pi \cdot C_C \cdot R_C} \quad (10)$$

where R<sub>C</sub> is compensation resistor.

The system crossover frequency (f<sub>c</sub>), where the control loop has unity gain, is recommended to be set at 1/10<sup>th</sup> of switching frequency. Generally, higher f<sub>c</sub> means faster response to load transients, but can result in instability if not properly compensated.

The first step in compensation design is choosing the compensation resistor (R<sub>C</sub>) to set the crossover frequency by the following equation:

$$R_C = \frac{2\pi \cdot C_{OUT} \cdot f_c \cdot V_{OUT}}{G_{CS} \cdot G_{EA} \cdot V_{FB}} \quad (11)$$

where V<sub>FB</sub> is reference voltage.

The next step is choosing the compensation capacitor (C<sub>C</sub>) to achieve the desired phase margin. For applications with typical inductor values, setting the compensation zero, f<sub>z2</sub>, to below one fourth of the crossover frequency provides sufficient phase margin. Determine the (C<sub>C</sub>) value by the following equation:

$$C_C = \frac{2}{\pi \cdot R_C \cdot f_c} \quad (12)$$

Then determine if the second compensation capacitor (C<sub>A</sub>) is required. It is required if the ESR zero of the output capacitor is located at less than half of the switching frequency.

$$\frac{1}{2\pi \cdot C_{OUT} \cdot ESR} < \frac{f_S}{2} \quad (13)$$

If required, add the second compensation capacitor (C<sub>A</sub>) to set the pole f<sub>p3</sub> at the location of the ESR zero. Determine (C<sub>A</sub>) value by the equation:

$$C_A = \frac{C_{OUT} \cdot ESR}{R_C} \quad (14)$$

### Design Example

Table 2 provides component values for delivering various output voltages with loads up to 1 A with V<sub>IN</sub> at 5 V (±10% tolerance).

**Table 2. Recommended Feedback and Compensation Values (V<sub>IN</sub>=5 V)**

V <sub>O</sub>	C <sub>4</sub>	L <sub>1</sub>	R <sub>2</sub>	R <sub>3</sub>	R <sub>1</sub>	C <sub>5</sub>	C <sub>2</sub>
1.2 V	10 μF	3.3 μH	Short	Open	4.7 kΩ	1.5 nF	150 pF
1.5 V			2.55 kΩ	10.2 kΩ			
1.8 V			5.9 kΩ	11.8 kΩ			
2.5 V			16.2 kΩ	15 kΩ			
3.3 V			18.7 kΩ	10.7 kΩ			

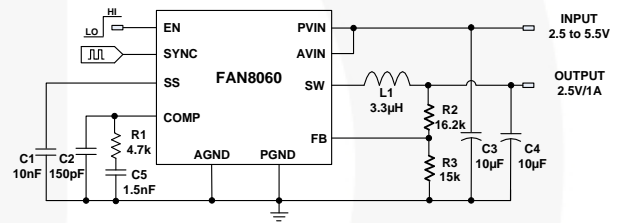

**Figure 15. Recommended Schematic (5 V<sub>IN</sub> to 2.5 V<sub>O</sub>)**

## PCB Layout Recommendations

The switching power supply PCB layout needs careful attention and is critical to achieving low losses and clean and stable operation. Although each design is different, below are some general recommendations for a good PCB layout.

- Keep the high-current traces and load connectors as short and wide as possible. These traces consist of VIN, GND, VOUT, and SW.
- Place the input capacitor, the inductor, and the output capacitor as close as possible to the IC terminals.
- Keep the loop area between SW node, inductor, and output capacitors as small as possible; minimizing ground loops to reduce EMI issues.
- Route high-dV/dt signals, such as SW node, away from the error amplifier input/output pins.
- Keep components connected to the FB and COMP pins close to the pins.

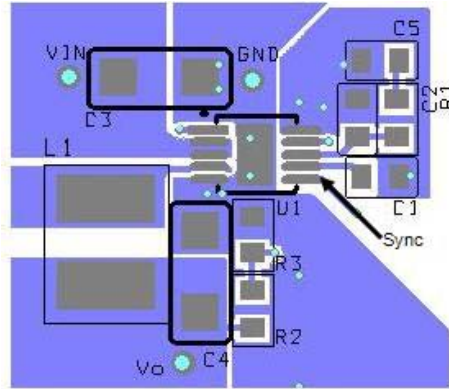
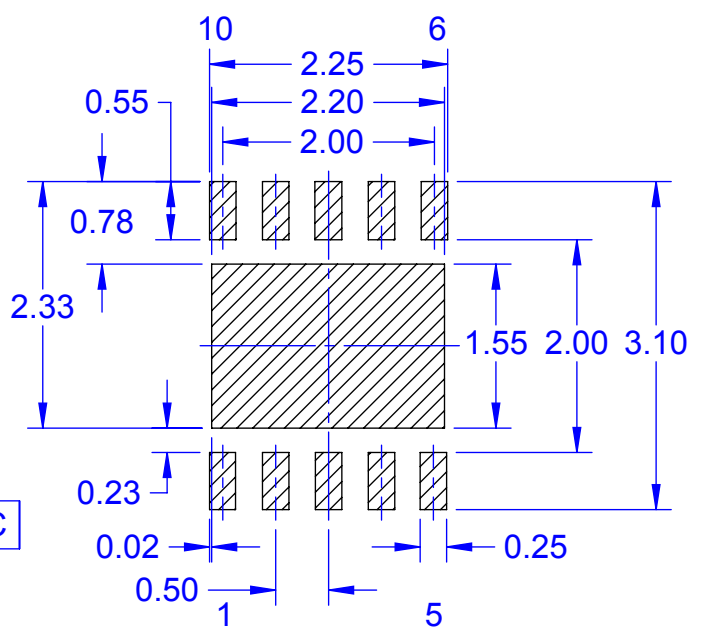
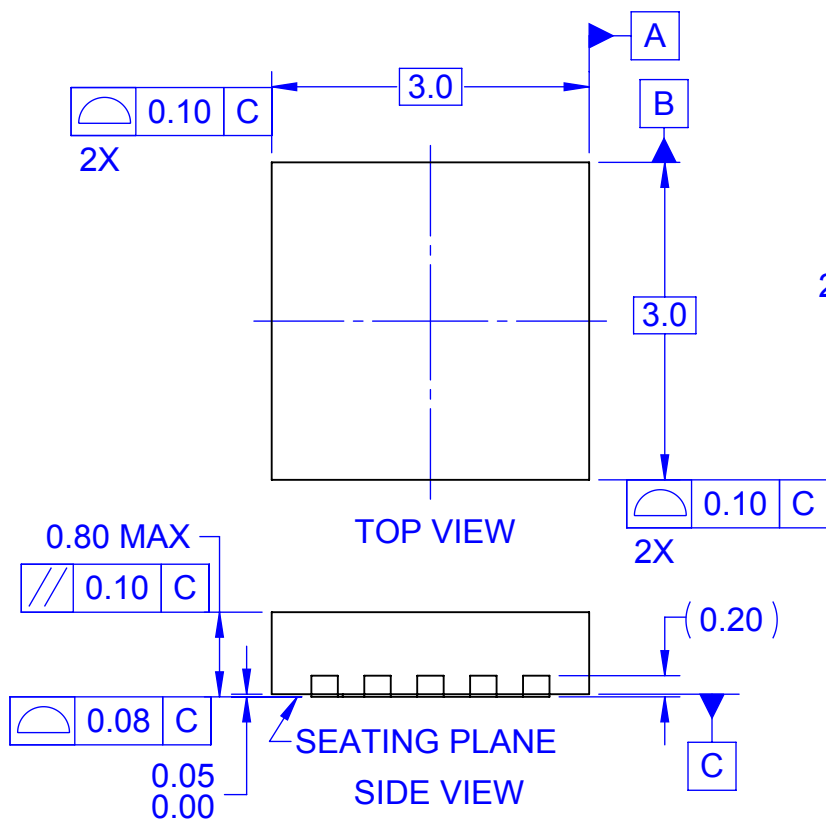

Figure 16. Recommended PCB Layout



**D**

LAND PATTERN RECOMMENDATION

NOTES:

- A. CONFORMS TO JEDEC REGISTRATION MO-229, VARIATION WEED-5
- B. DIMENSIONS ARE IN MILLIMETERS
- C. DIMENSIONS AND TOLERANCES PER ASME Y14.5M, 2009
- D. LAND PATTERN DIMENSIONS ARE NOMINAL REFERENCE VALUES ONLY
- E. DRAWING FILENAME: MKT-MLP10Brev2

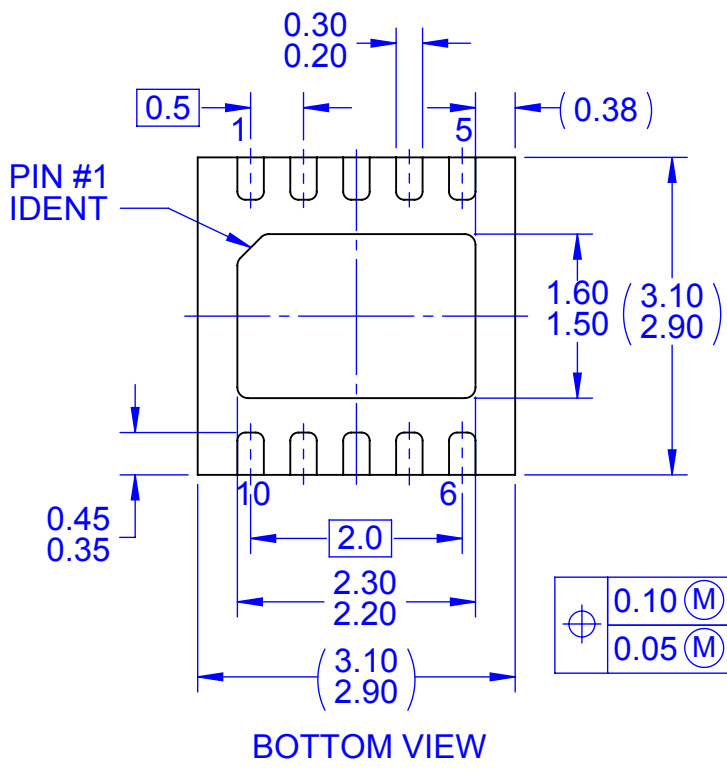

⊕	0.10 (M)	C	A	B
	0.05 (M)	C		



ON Semiconductor and  are trademarks of Semiconductor Components Industries, LLC dba ON Semiconductor or its subsidiaries in the United States and/or other countries. ON Semiconductor owns the rights to a number of patents, trademarks, copyrights, trade secrets, and other intellectual property. A listing of ON Semiconductor's product/patent coverage may be accessed at [www.onsemi.com/site/pdf/Patent-Marking.pdf](http://www.onsemi.com/site/pdf/Patent-Marking.pdf). ON Semiconductor reserves the right to make changes without further notice to any products herein. ON Semiconductor makes no warranty, representation or guarantee regarding the suitability of its products for any particular purpose, nor does ON Semiconductor assume any liability arising out of the application or use of any product or circuit, and specifically disclaims any and all liability, including without limitation special, consequential or incidental damages. Buyer is responsible for its products and applications using ON Semiconductor products, including compliance with all laws, regulations and safety requirements or standards, regardless of any support or applications information provided by ON Semiconductor. "Typical" parameters which may be provided in ON Semiconductor data sheets and/or specifications can and do vary in different applications and actual performance may vary over time. All operating parameters, including "Typicals" must be validated for each customer application by customer's technical experts. ON Semiconductor does not convey any license under its patent rights nor the rights of others. ON Semiconductor products are not designed, intended, or authorized for use as a critical component in life support systems or any FDA Class 3 medical devices or medical devices with a same or similar classification in a foreign jurisdiction or any devices intended for implantation in the human body. Should Buyer purchase or use ON Semiconductor products for any such unintended or unauthorized application, Buyer shall indemnify and hold ON Semiconductor and its officers, employees, subsidiaries, affiliates, and distributors harmless against all claims, costs, damages, and expenses, and reasonable attorney fees arising out of, directly or indirectly, any claim of personal injury or death associated with such unintended or unauthorized use, even if such claim alleges that ON Semiconductor was negligent regarding the design or manufacture of the part. ON Semiconductor is an Equal Opportunity/Affirmative Action Employer. This literature is subject to all applicable copyright laws and is not for resale in any manner.

## PUBLICATION ORDERING INFORMATION

### LITERATURE FULFILLMENT:

Literature Distribution Center for ON Semiconductor  
19521 E. 32nd Pkwy, Aurora, Colorado 80011 USA  
**Phone:** 303-675-2175 or 800-344-3860 Toll Free USA/Canada  
**Fax:** 303-675-2176 or 800-344-3867 Toll Free USA/Canada  
**Email:** [orderlit@onsemi.com](mailto:orderlit@onsemi.com)

**N. American Technical Support:** 800-282-9855 Toll Free  
USA/Canada  
**Europe, Middle East and Africa Technical Support:**  
Phone: 421 33 790 2910  
**Japan Customer Focus Center**  
Phone: 81-3-5817-1050

**ON Semiconductor Website:** [www.onsemi.com](http://www.onsemi.com)  
**Order Literature:** <http://www.onsemi.com/orderlit>  
For additional information, please contact your local  
Sales Representative