

NB100LVEP221

2.5V/3.3V 2:1:20 Differential HSTL/ECL/PECL Clock Driver

Description

The NB100LVEP221 is a low skew 2:1:20 differential clock driver, designed with clock distribution in mind, accepting two clock sources into an input multiplexer. The two clock inputs are differential ECL/PECL; CLK1/ $\overline{\text{CLK1}}$ can also receive HSTL signal levels. The LVPECL input signals can be either differential configuration or single-ended (if the V_{BB} output is used).

The LVEP221 specifically guarantees low output-to-output skew. Optimal design, layout, and processing minimize skew within a device and from device to device.

To ensure tightest skew, both sides of differential outputs should be terminated identically into 50 Ω even if only one output is being used. If an output pair is unused, both outputs may be left open (unterminated) without affecting skew.

The NB100LVEP221, as with most other ECL devices, can be operated from a positive V_{CC} supply in LVPECL mode. This allows the LVEP221 to be used for high performance clock distribution in +3.3 V or +2.5 V systems. In a PECL environment, series or Thevenin line terminations are typically used as they require no additional power supplies. For more information on PECL terminations, designers should refer to Application Note AND8020/D.

The V_{BB} pin, an internally generated voltage supply, is available to this device only. For single-ended LVPECL input conditions, the unused differential input is connected to V_{BB} as a switching reference voltage. V_{BB} may also rebias AC coupled inputs. When used, decouple V_{BB} and V_{CC} via a 0.01 μF capacitor and limit current sourcing or sinking to 0.5 mA. When not used, V_{BB} should be left open.

Single-ended CLK input operation is limited to a $V_{\text{CC}} \geq 3.0$ V in LVPECL mode, or $V_{\text{EE}} \leq -3.0$ V in NECL mode.

Features

- 15 ps Typical Output-to-Output Skew
- 40 ps Typical Device-to-Device Skew
- Jitter Less than 2 ps RMS
- Maximum Frequency > 1.0 GHz Typical
- Thermally Enhanced 52-Lead QFN Package
- V_{BB} Output
- 540 ps Typical Propagation Delay
- LVPECL and HSTL Mode Operating Range:
 $V_{\text{CC}} = 2.375$ V to 3.8 V with $V_{\text{EE}} = 0$ V
- NECL Mode Operating Range:
 $V_{\text{CC}} = 0$ V with $V_{\text{EE}} = -2.375$ V to -3.8 V
- Q Output will Default Low with Inputs Open or at V_{EE}
- Pin Compatible with Motorola MC100EP221
- These Devices are Pb-Free and are RoHS Compliant



ON Semiconductor®

www.onsemi.com

MARKING DIAGRAM*

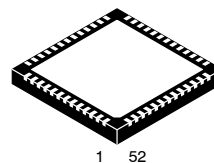

QFN52
MN SUFFIX
CASE 485M

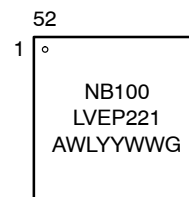

A = Assembly Location
WL = Wafer Lot
YY = Year
WW = Work Week
G = Pb-Free Package

*For additional marking information, refer to Application Note AND8002/D.

ORDERING INFORMATION

See detailed ordering and shipping information in the package dimensions section on page 8 of this data sheet.

NB100LVEP221

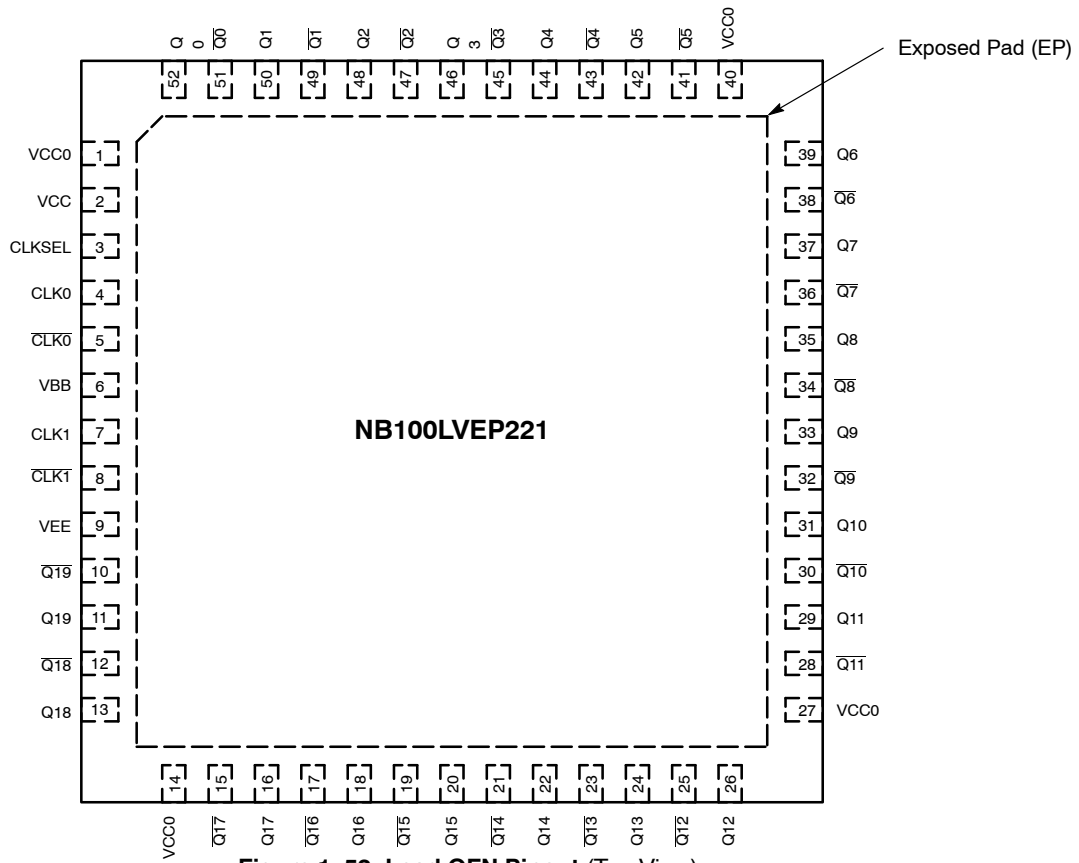

Figure 1. 52-Lead QFN Pinout (Top View)

Table 1. PIN DESCRIPTION

PIN	FUNCTION
CLK0*, $\overline{\text{CLK0}}$ **	ECL/PECL Differential Inputs
CLK1*, $\overline{\text{CLK1}}$ **	ECL/PECL or HSTL Differential Inputs
Q0:19, $\overline{\text{Q0}}$: $\overline{\text{Q19}}$	ECL/PECL Differential Outputs
CLK_SEL*	ECL/PECL Active Clock Select Input
V _{BB}	Reference Voltage Output
V _{CC} /V _{CC0}	Positive Supply
V _{EE} ***	Negative Supply

* Pins will default LOW when left open.

** Pins will default HIGH when left open.

*** The thermally conductive exposed pad on the bottom of the package is electrically connected to V_{EE} internally.

Table 2. FUNCTION TABLE

CLK_SEL	Active Input
L	CLK0, $\overline{\text{CLK0}}$
H	CLK1, $\overline{\text{CLK1}}$

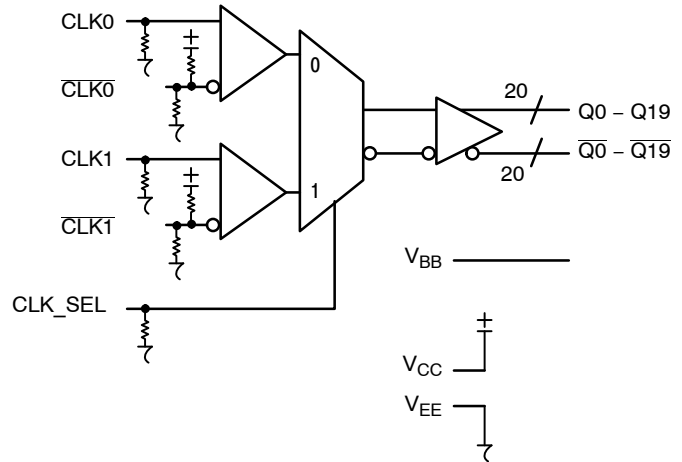

Figure 2. Logic Diagram

NB100LVEP221

Table 3. ATTRIBUTES

Characteristics		Value
Internal Input Pulldown Resistor		75 kΩ
Internal Input Pullup Resistor		37.5 kΩ
ESD Protection	Human Body Model	> 2 kV
	Machine Model	> 200 V
	Charged Device Model	> 2 kV
Moisture Sensitivity, Indefinite Time Out of Drypack (Note 1)		Pb-Free Pkg
QFN52		Level 2
Flammability Rating	Oxygen Index: 28 to 34	UL 94 V-0 @ 0.125 in
Transistor Count		533 Devices
Meets or exceeds JEDEC Spec EIA/JESD78 IC Latchup Test		

1. For additional information, refer to Application Note AND8003/D.

Table 4. MAXIMUM RATINGS

Symbol	Parameter	Condition 1	Condition 2	Rating	Unit
V _{CC}	PECL Mode Power Supply	V _{EE} = 0 V		6	V
V _{EE}	NECL Mode Power Supply	V _{CC} = 0 V		-6	V
V _I	PECL Mode Input Voltage	V _{EE} = 0 V	V _I ≤ V _{CC}	6	V
	NECL Mode Input Voltage	V _{CC} = 0 V	V _I ≥ V _{EE}	-6	V
I _{out}	Output Current	Continuous Surge		50	mA
				100	mA
I _{BB}	V _{BB} Sink/Source			± 0.5	mA
T _A	Operating Temperature Range			-40 to +85	°C
T _{stg}	Storage Temperature Range			-65 to +150	°C
θ _{JA}	Thermal Resistance (Junction-to-Ambient) (Note)	0 lfpm	QFN52	25	°C/W
		500 lfpm	QFN52	19.6	°C/W
θ _{JC}	Thermal Resistance (Junction-to-Case) (Note)	2S2P	QFN52	21	°C/W
T _{sol}	Wave Solder	Pb Pb-Free		265	°C
				265	°C

Stresses exceeding those listed in the Maximum Ratings table may damage the device. If any of these limits are exceeded, device functionality should not be assumed, damage may occur and reliability may be affected.

NB100LVEP221

Table 5. LVPECL DC CHARACTERISTICS $V_{CC} = 2.5\text{ V}$; $V_{EE} = 0\text{ V}$ (Note 2)

Symbol	Characteristic	-40°C			25°C			85°C			Unit
		Min	Typ	Max	Min	Typ	Max	Min	Typ	Max	
I_{EE}	Power Supply Current	100	125	150	104	130	156	116	145	174	mA
V_{OH}	Output HIGH Voltage (Note 3)	1355	1480	1605	1355	1480	1605	1355	1480	1605	mV
V_{OL}	Output LOW Voltage (Note 3)	555	680	900	555	680	900	555	680	900	mV
V_{IH}	Input HIGH Voltage (Single-Ended) (Note 4)	1335		1620	1335		1620	1275		1620	mV
V_{IL}	Input LOW Voltage (Single-Ended) (Note 4)	555		900	555		900	555		900	mV
V_{IHCMR}	Input HIGH Voltage Common Mode Range (Differential Configuration) (Note 5) CLK0/CLK0 CLK1/CLK1	1.2 0.3		2.5 1.6	1.2 0.3		2.5 1.6	1.2 0.3		2.5 1.6	V V
I_{IH}	Input HIGH Current			150			150			150	μA
I_{IL}	Input LOW Current CLK CLK	0.5 -150			0.5 -150			0.5 -150			μA

NOTE: Device will meet the specifications after thermal equilibrium has been established when mounted in a test socket or printed circuit board with maintained transverse airflow greater than 500 lfm.

- Input and output parameters vary 1:1 with V_{CC} . V_{EE} can vary + 0.125 V to -1.3 V.
- All outputs loaded with 50 Ω to $V_{CC} - 2.0\text{ V}$.
- Do not use V_{BB} at $V_{CC} < 3.0\text{ V}$.
- V_{IHCMR} min varies 1:1 with V_{EE} , V_{IHCMR} max varies 1:1 with V_{CC} . The V_{IHCMR} range is referenced to the most positive side of the differential input signal.

Table 6. LVPECL DC CHARACTERISTICS $V_{CC} = 3.3\text{ V}$; $V_{EE} = 0\text{ V}$ (Note 6)

Symbol	Characteristic	-40°C			25°C			85°C			Unit
		Min	Typ	Max	Min	Typ	Max	Min	Typ	Max	
I_{EE}	Power Supply Current	100	125	150	104	130	156	116	145	174	mA
V_{OH}	Output HIGH Voltage (Note 7)	2155	2280	2405	2155	2280	2405	2155	2280	2405	mV
V_{OL}	Output LOW Voltage (Note 7)	1355	1480	1700	1355	1480	1700	1355	1480	1700	mV
V_{IH}	Input HIGH Voltage (Single-Ended)	2135		2420	2135		2420	2135		2420	mV
V_{IL}	Input LOW Voltage (Single-Ended)	1355		1700	1355		1700	1355		1700	mV
V_{BB}	Output Reference Voltage (Note 8)	1775	1875	1975	1775	1875	1975	1775	1875	1975	mV
V_{IHCMR}	Input HIGH Voltage Common Mode Range (Differential Configuration) (Note 9) CLK0/CLK0 CLK1/CLK1	1.2 0.3		3.3 1.6	1.2 0.3		3.3 1.6	1.2 0.3		3.3 1.6	V V
I_{IH}	Input HIGH Current			150			150			150	μA
I_{IL}	Input LOW Current CLK CLK	0.5 -150			0.5 -150			0.5 -150			μA

NOTE: Device will meet the specifications after thermal equilibrium has been established when mounted in a test socket or printed circuit board with maintained transverse airflow greater than 500 lfm.

- Input and output parameters vary 1:1 with V_{CC} . V_{EE} can vary + 0.925 V to -0.5 V.
- All outputs loaded with 50 Ω to $V_{CC} - 2.0\text{ V}$.
- Single-ended input operation is limited $V_{CC} \geq 3.0\text{ V}$ in LVPECL mode.
- V_{IHCMR} min varies 1:1 with V_{EE} , V_{IHCMR} max varies 1:1 with V_{CC} . The V_{IHCMR} range is referenced to the most positive side of the differential input signal.

NB100LVEP221

Table 7. LVNECL DC CHARACTERISTICS $V_{CC} = 0\text{ V}$, $V_{EE} = -2.375\text{ V to } -3.8\text{ V}$ (Note 10)

Symbol	Characteristic	-40°C			25°C			85°C			Unit
		Min	Typ	Max	Min	Typ	Max	Min	Typ	Max	
I_{EE}	Power Supply Current	100	125	150	104	130	156	116	145	174	mA
V_{OH}	Output HIGH Voltage (Note 11)	-1145	-1020	-895	-1145	-1020	-895	-1145	-1020	-895	mV
V_{OL}	Output LOW Voltage (Note 11)	-1945	-1820	-1600	-1945	-1820	-1600	-1945	-1820	-1600	mV
V_{IH}	Input HIGH Voltage (Single-Ended)	-1165		-880	-1165		-880	-1165		-880	mV
V_{IL}	Input LOW Voltage (Single-Ended)	-1945		-1600	-1945		-1600	-1945		-1600	mV
V_{BB}	Output Reference Voltage (Note 12)	-1525	-1425	-1325	-1525	-1425	-1325	-1525	-1425	-1325	mV
V_{IHCMR}	Input HIGH Voltage Common Mode Range (Differential Configuration) (Note 13) CLK0/ $\overline{\text{CLK0}}$ CLK1/ $\overline{\text{CLK1}}$	$V_{EE} + 1.2$ $V_{EE} + 0.3$		0.0 -0.9	$V_{EE} + 1.2$ $V_{EE} + 0.3$		0.0 -0.9	$V_{EE} + 1.2$ $V_{EE} + 0.3$		0.0 -0.9	V V
I_{IH}	Input HIGH Current			150			150			150	μA
I_{IL}	Input LOW Current CLK CLK	0.5 -150			0.5 -150			0.5 -150			μA

NOTE: Device will meet the specifications after thermal equilibrium has been established when mounted in a test socket or printed circuit board with maintained transverse airflow greater than 500 lfm.

10. Input and output parameters vary 1:1 with V_{CC} .

11. All outputs loaded with $50\ \Omega$ to $V_{CC}-2.0\text{ V}$.

12. Single-ended input operation is limited $V_{EE} \leq -3.0\text{V}$ in NECL mode.

13. V_{IHCMR} min varies 1:1 with V_{EE} , V_{IHCMR} max varies 1:1 with V_{CC} . The V_{IHCMR} range is referenced to the most positive side of the differential input signal.

Table 8. HSTL DC CHARACTERISTICS $V_{CC} = 3.3\text{ V}$; $V_{EE} = 0\text{ V}$

Symbol	Characteristic	0°C			25°C			85°C			Unit
		Min	Typ	Max	Min	Typ	Max	Min	Typ	Max	
V_{IH}	Input HIGH Voltage CLK1/ $\overline{\text{CLK1}}$	V_x+100		1600	V_x+100		1600	V_x+100		1600	mV
V_{IL}	Input LOW Voltage CLK1/ $\overline{\text{CLK1}}$	-300		V_x-100	-300		V_x-100	-300		V_x-100	mV
V_X	Differential Configuration Cross Point Voltage	680		900	680		900	680		900	mV
I_{IH}	Input HIGH Current	-150		150	-150		150	-150		150	μA
I_{IL}	Input LOW Current CLK1 CLK1	-150 -250			-150 -250			-150 -250			μA

NOTE: Device will meet the specifications after thermal equilibrium has been established when mounted in a test socket or printed circuit board with maintained transverse airflow greater than 500 lfm.

NB100LVEP221

Table 9. AC CHARACTERISTICS $V_{CC} = 0\text{ V}$; $V_{EE} = -2.375\text{ to }-3.8\text{ V}$ or $V_{CC} = 2.375\text{ to }3.8\text{ V}$; $V_{EE} = 0\text{ V}$ (Note 14)

Symbol	Characteristic	-40°C			25°C			85°C			Unit	
		Min	Typ	Max	Min	Typ	Max	Min	Typ	Max		
V_{Opp}	Differential Output Voltage (Figure 3)	$f_{out} < 50\text{ MHz}$	550	700		600	700		600	700		mV
		$f_{out} < 0.8\text{ GHz}$	550	700		550	700		500	700		mV
		$f_{out} < 1.0\text{ GHz}$	500	700		500	700		400	600		mV
t_{PLH}/t_{PHL}	Propagation Delay (Differential Configuration) CLK0-Qx CLK1-Qx		540	600		540	660		540	750		ps
			590	640		590	710		590	800		ps
t_{skew}	Within-Device Skew (Note 15)		15	50		15	50		15	50		ps
	Device-to-Device Skew (Note 16)		40	200		40	200		40	200		ps
t_{JITTER}	Random Clock Jitter (RMS) (Figure 3)		1	2		1	2		1	2		ps
V_{pp}	Input Swing (Differential Configuration) (Note 17) (Figure 4)	CLK0	400	800	1200	400	800	1200	400	800	1200	mV
		CLK1 HSTL	300	800	1000	300	800	1000	300	800	1000	mV
DCO	Output Duty Cycle	49.5	50	50.5	49.5	50	50.5	49.5	50	50.5		%
t_r/t_f	Output Rise/Fall Time (20%–80%)	100	200	300	100	200	300	150	250	350		ps

NOTE: Device will meet the specifications after thermal equilibrium has been established when mounted in a test socket or printed circuit board with maintained transverse airflow greater than 500 lfm.

14. Measured with 750 mV source (LVPECL) or 1 V (HSTL) source, 50% duty cycle clock source. All outputs loaded with 50 Ω to $V_{CC}-2\text{ V}$.

15. Skew is measured between outputs under identical transitions and conditions on any one device.

16. Device-to-Device skew for identical transitions, outputs and V_{CC} levels.

17. V_{pp} is the differential configuration input voltage swing required to maintain AC characteristics.

NB100LVEP221

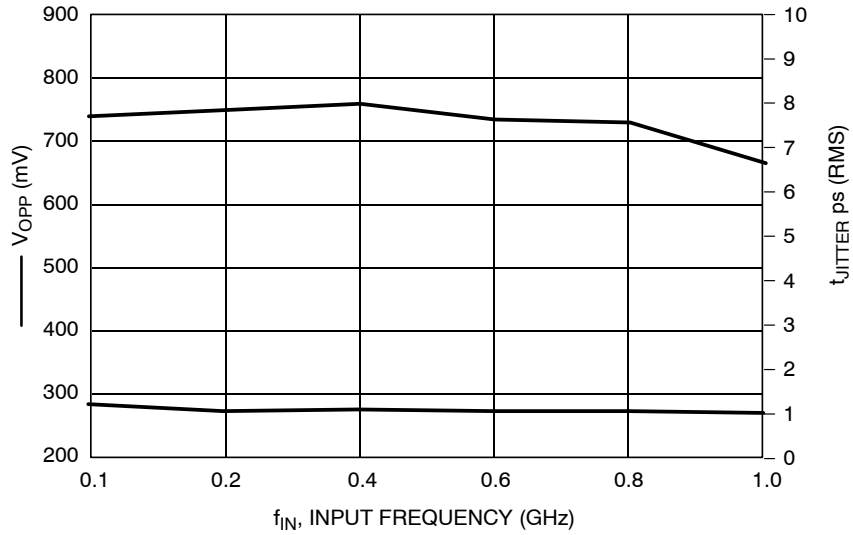

Figure 3. Output Voltage (V_{OPP})/Jitter versus Input Frequency ($V_{CC} - V_{EE} = 3.3 \text{ V} @ 25^\circ\text{C}$)

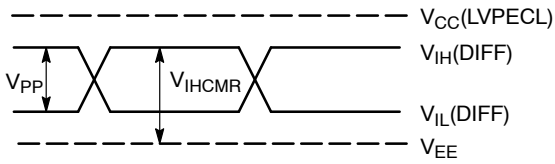

Figure 4. LVPECL Differential Input Levels

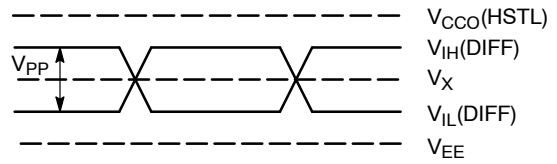

Figure 5. HSTL Differential Input Levels

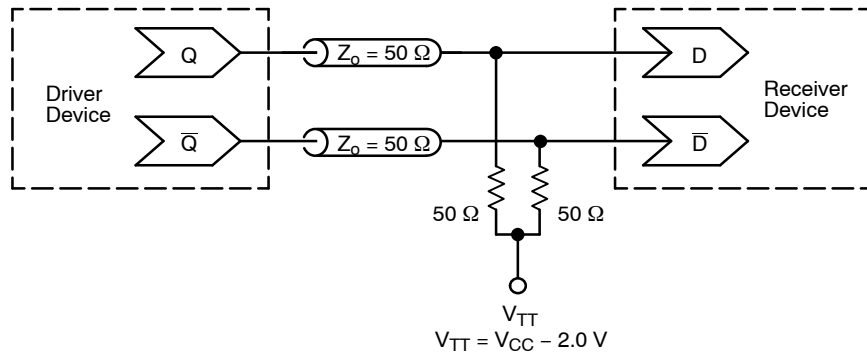

Figure 6. Typical Termination for Output Driver and Device Evaluation (See Application Note AND8020/D – Termination of ECL Logic Devices.)

NB100LVEP221

ORDERING INFORMATION

Device	Package	Shipping†
NB100LVEP221MNRG	QFN52 (Pb-Free)	2000 / Tape & Reel

†For information on tape and reel specifications, including part orientation and tape sizes, please refer to our Tape and Reel Packaging Specifications Brochure, BRD8011/D.

Resource Reference of Application Notes

- AN1405/D** - ECL Clock Distribution Techniques
- AN1406/D** - Designing with PECL (ECL at +5.0 V)
- AN1503/D** - ECLinPS™ I/O SPICE Modeling Kit
- AN1504/D** - Metastability and the ECLinPS Family
- AN1568/D** - Interfacing Between LVDS and ECL
- AN1672/D** - The ECL Translator Guide
- AND8001/D** - Odd Number Counters Design
- AND8002/D** - Marking and Date Codes
- AND8020/D** - Termination of ECL Logic Devices
- AND8066/D** - Interfacing with ECLinPS
- AND8090/D** - AC Characteristics of ECL Devices

MECHANICAL CASE OUTLINE

PACKAGE DIMENSIONS

ON Semiconductor®



QFN52 8x8, 0.5P
CASE 485M-01
ISSUE C

DATE 16 FEB 2010

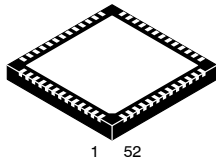

SCALE 2:1

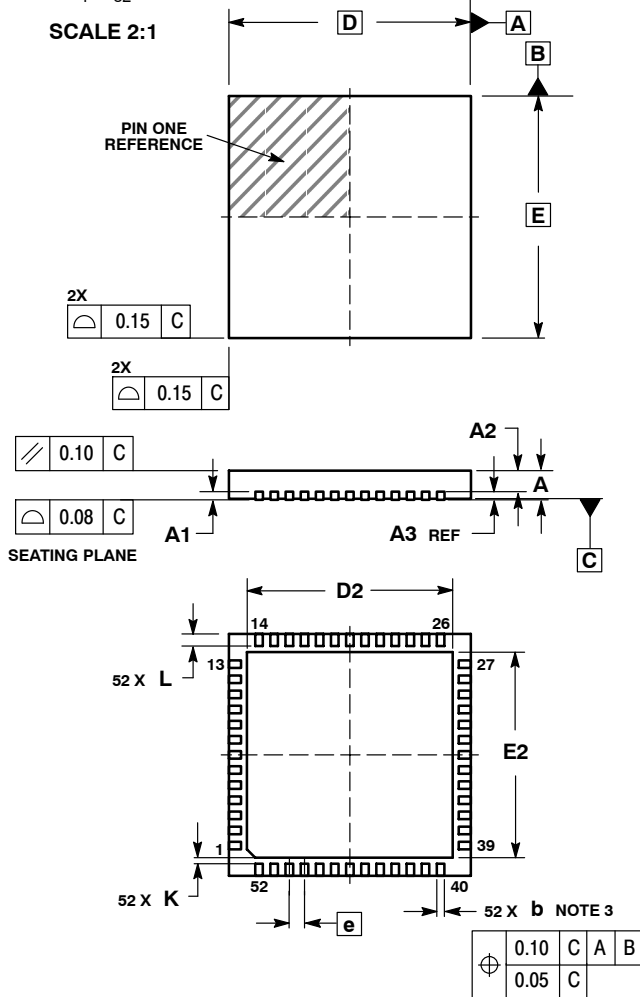

NOTES:

1. DIMENSIONING AND TOLERANCING PER ASME Y14.5M, 1994.
2. CONTROLLING DIMENSION: MILLIMETERS
3. DIMENSION b APPLIES TO PLATED TERMINAL AND IS MEASURED BETWEEN 0.25 AND 0.30 MM FROM TERMINAL.
4. COPLANARITY APPLIES TO THE EXPOSED PAD AS WELL AS THE TERMINALS.

MILLIMETERS		
DIM	MIN	MAX
A	0.80	1.00
A1	0.00	0.05
A2	0.60	0.80
A3	0.20 REF	
b	0.18	0.30
D	8.00 BSC	
D2	6.50	6.80
E	8.00 BSC	
E2	6.50	6.80
e	0.50 BSC	
K	0.20	---
L	0.30	0.50

GENERIC MARKING DIAGRAM

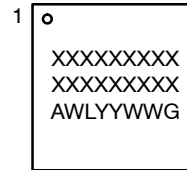

- XXXXXXXXXX = Device Code
- A = Assembly Site
- WL = Wafer Lot
- YY = Year
- WW = Work Week
- G = Pb-Free Package

RECOMMENDED SOLDERING FOOTPRINT

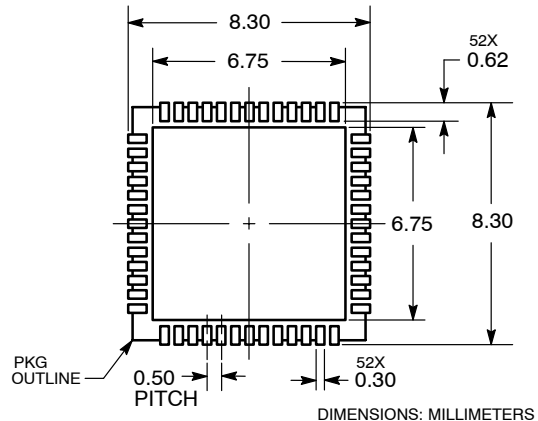

DOCUMENT NUMBER:	98AON12057D	Electronic versions are uncontrolled except when accessed directly from the Document Repository. Printed versions are uncontrolled except when stamped "CONTROLLED COPY" in red.
DESCRIPTION:	52 PIN QFN, 8X8, 0.5P	PAGE 1 OF 1

ON Semiconductor and are trademarks of Semiconductor Components Industries, LLC dba ON Semiconductor or its subsidiaries in the United States and/or other countries. ON Semiconductor reserves the right to make changes without further notice to any products herein. ON Semiconductor makes no warranty, representation or guarantee regarding the suitability of its products for any particular purpose, nor does ON Semiconductor assume any liability arising out of the application or use of any product or circuit, and specifically disclaims any and all liability, including without limitation special, consequential or incidental damages. ON Semiconductor does not convey any license under its patent rights nor the rights of others.

onsemi, **Onsemi**, and other names, marks, and brands are registered and/or common law trademarks of Semiconductor Components Industries, LLC dba "**onsemi**" or its affiliates and/or subsidiaries in the United States and/or other countries. **onsemi** owns the rights to a number of patents, trademarks, copyrights, trade secrets, and other intellectual property. A listing of **onsemi**'s product/patent coverage may be accessed at www.onsemi.com/site/pdf/Patent-Marking.pdf. **onsemi** reserves the right to make changes at any time to any products or information herein, without notice. The information herein is provided "as-is" and **onsemi** makes no warranty, representation or guarantee regarding the accuracy of the information, product features, availability, functionality, or suitability of its products for any particular purpose, nor does **onsemi** assume any liability arising out of the application or use of any product or circuit, and specifically disclaims any and all liability, including without limitation special, consequential or incidental damages. Buyer is responsible for its products and applications using **onsemi** products, including compliance with all laws, regulations and safety requirements or standards, regardless of any support or applications information provided by **onsemi**. "Typical" parameters which may be provided in **onsemi** data sheets and/or specifications can and do vary in different applications and actual performance may vary over time. All operating parameters, including "Typicals" must be validated for each customer application by customer's technical experts. **onsemi** does not convey any license under any of its intellectual property rights nor the rights of others. **onsemi** products are not designed, intended, or authorized for use as a critical component in life support systems or any FDA Class 3 medical devices or medical devices with a same or similar classification in a foreign jurisdiction or any devices intended for implantation in the human body. Should Buyer purchase or use **onsemi** products for any such unintended or unauthorized application, Buyer shall indemnify and hold **onsemi** and its officers, employees, subsidiaries, affiliates, and distributors harmless against all claims, costs, damages, and expenses, and reasonable attorney fees arising out of, directly or indirectly, any claim of personal injury or death associated with such unintended or unauthorized use, even if such claim alleges that **onsemi** was negligent regarding the design or manufacture of the part. **onsemi** is an Equal Opportunity/Affirmative Action Employer. This literature is subject to all applicable copyright laws and is not for resale in any manner.

ADDITIONAL INFORMATION

TECHNICAL PUBLICATIONS:

Technical Library: www.onsemi.com/design/resources/technical-documentation
onsemi Website: www.onsemi.com

ONLINE SUPPORT: www.onsemi.com/support

For additional information, please contact your local Sales Representative at www.onsemi.com/support/sales

