

# Ultra-Low Jitter, Low Skew 1:12 LVCMOS/LVTTL Fanout Buffer

## NB3V8312C

The NB3V8312C is a high performance, low skew LVCMOS fanout buffer which can distribute 12 ultra-low jitter clocks from an LVCMOS/LVTTL input up to 250 MHz.

The 12 LVCMOS output pins drive 50 Ω series or parallel terminated transmission lines. The outputs can also be disabled to a high impedance (tri-stated) via the OE input, or enabled when High.

The NB3V8312C provides an enable input, CLK\_EN pin, which synchronously enables or disables the clock outputs while in the LOW state. Since this input is internally synchronized to the input clock, changing only when the input is LOW, potential output glitching or runt pulse generation is eliminated.

Separate V<sub>DD</sub> core and V<sub>DDO</sub> output supplies allow the output buffers to operate at the same supply as the V<sub>DD</sub> (V<sub>DD</sub> = V<sub>DDO</sub>) or from a lower supply voltage. Compared to single-supply operation, dual supply operation enables lower power consumption and output-level compatibility.

The V<sub>DD</sub> core supply voltage can be set to 3.3 V, 2.5 V or 1.8 V, while the V<sub>DDO</sub> output supply voltage can be set to 3.3 V, 2.5 V, or 1.8 V, with the constraint that V<sub>DD</sub> ≥ V<sub>DDO</sub>.

This buffer is ideally suited for various networking, telecom, server and storage area networking, RRU LO reference distribution, medical and test equipment applications.

### Features

- Power Supply Modes:
 

V <sub>DD</sub> (Core) / V <sub>DDO</sub> (Outputs)
3.3 V / 3.3 V
3.3 V / 2.5 V
3.3 V / 1.8 V
2.5 V / 2.5 V
2.5 V / 1.8 V
1.8 V / 1.8 V
- 250 MHz Maximum Clock Frequency
- Accepts LVCMOS, LVTTL Clock Inputs
- LVCMOS Compatible Control Inputs
- 12 LVCMOS Clock Outputs
- Synchronous Clock Enable
- Output Enable to High Z State Control
- 150 ps Max. Skew Between Outputs
- Temp. Range -40°C to +85°C
- 32-pin LQFP and QFN Packages
- These are Pb-Free Devices

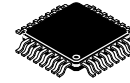

LQFP-32  
FA SUFFIX  
CASE 561AB

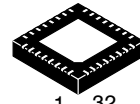

QFN32  
MN SUFFIX  
CASE 488AM

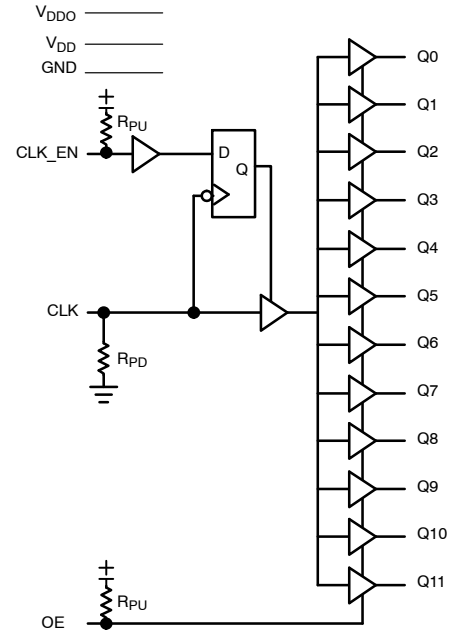

Figure 1. Simplified Logic Diagram

### ORDERING AND MARKING INFORMATION

See detailed ordering and shipping information on page 9 of this data sheet.

### Applications

- Networking
- Telecom
- Storage Area Network

### End Products

- Servers
- Routers
- Switches

# NB3V8312C

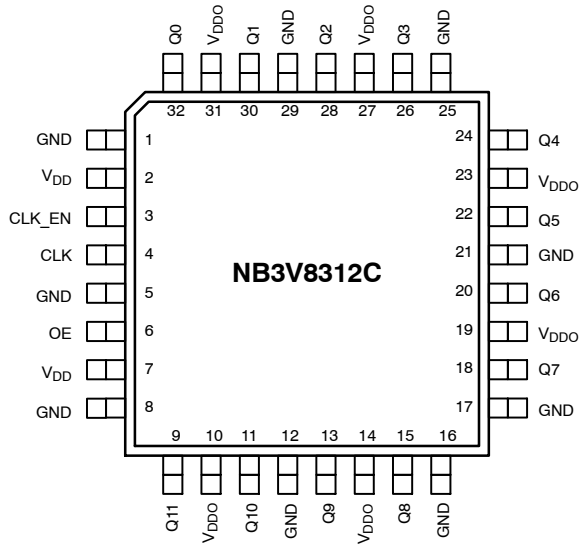

**Figure 2. LQFP-32 Pinout Configuration**  
(Top View)

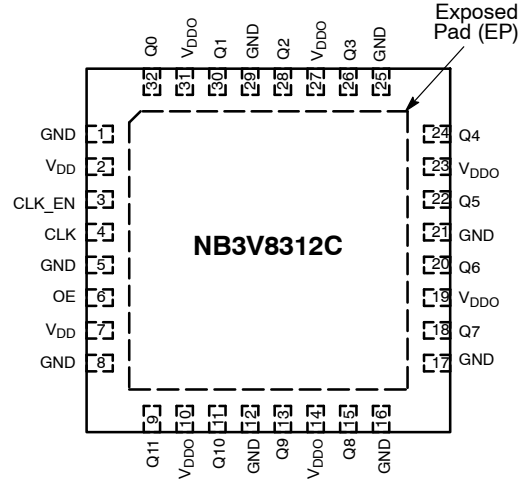

**Figure 3. QFN32 Pinout Configuration**  
(Top View)

**Table 1. PIN DESCRIPTION**

Pin	Name	I/O	Open Default	Description
1, 5, 8, 12, 16, 17, 21, 25, 29	GND	Power		Ground, Negative Power Supply
2, 7	VDD	Power		Positive Supply for Core and Inputs
3	CLK_EN	Input	High	Synchronous Clock Enable Input. When High, outputs are enabled. When Low, outputs are disabled Low. Internal Pullup Resistor.
4	CLK	Input	Low	Single-ended Clock input; LVCMOS/LVTTL. Internal Pull-down Resistor.
6	OE	Input	High	Output Enable. Internal Pullup Resistor.
9, 11, 13, 15, 18, 20, 22, 24, 26, 28, 30, 32	Q11, Q10, Q9, Q8, Q7, Q6, Q5, Q4, Q3, Q2, Q1, Q0	Output		Single-ended LVCMOS/LVTTL outputs
10, 14, 19, 23, 27, 31	VDD0	Power		Positive Supply for Outputs
-	EP	-	-	The Exposed Pad (EP) on the package bottom is thermally connected to the die for improved heat transfer out of package. The exposed pad must be attached to a heat-sinking conduit. The pad is connected to the die and must only be connected electrically to GND on the PC board.

- All VDD, VDD0 and GND pins must be externally connected to a power supply to guarantee proper operation. Bypass each supply pin with 0.01  $\mu$ F to GND.

## NB3V8312C

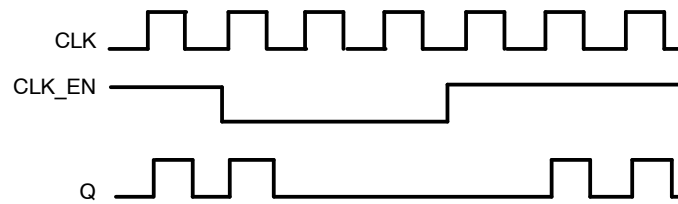

**Figure 4. CLK\_EN Control Timing Diagram**

**Table 2. OE, CLK\_EN FUNCTION TABLES**

Inputs			Outputs
OE	CLK_EN (Note 2)	CLK	Q[0:11]
0	X	X	Hi-Z
1	0	X	Low
1	1	0	Low
1	1	1	High

2. The CLK\_EN control input synchronously enables or disables the outputs as shown in Figure 4. This control latches on the falling edge of the selected input CLK. When CLK\_EN is LOW, the outputs are disabled in a LOW state. When CLK\_EN is HIGH, the outputs are enabled as shown. CLK\_EN to CLK Set up and Hold times must be satisfied.

**Table 3. ATTRIBUTES** (Note 3)

Characteristics	Value
Internal Input Pullup ( $R_{PU}$ ) and Pulldown ( $R_{PD}$ ) Resistor	50 k $\Omega$
Input Capacitance, $C_{IN}$	4 pF
Power Dissipation Capacitance, $C_{PD}$ (per Output)	20 pF
$R_{OUT}$	8 $\Omega$
ESD Protection	Human Body Model Machine Model
Moisture Sensitivity (Note 3)	LQFP QFN
Flammability Rating Oxygen Index	UL-94 code V-0 A 1/8" 28 to 34
Transistor Count	464 Devices
Meets or exceeds JEDEC Spec EIA/JESD78 IC Latchup Test	

3. For additional information, see Application Note [AND8003/D](#).

# NB3V8312C

**Table 4. MAXIMUM RATINGS** (Note 4)

Symbol	Parameter	Condition		Rating	Unit
$V_{DD} / V_{DDO}$	Positive Power Supply	GND = 0 V		4.6	V
$V_I$	Input Voltage			$-0.5 \leq V_I \leq V_{DD} + 0.5$	V
$T_{stg}$	Storage Temperature Range			-65 to +150	°C
$\theta_{JA}$	Thermal Resistance (Junction-to-Ambient) (Note 5)	0 lfpm 500 lfpm	LQFP-32 LQFP-32	80 55	°C/W °C/W
$\theta_{JC}$	Thermal Resistance (Junction-to-Case) (Note 5)	Standard Board	LQFP-32 LQFP-32	12-17	°C/W
$\theta_{JA}$	Thermal Resistance (Junction-to-Ambient) (Note 5)	0 lfpm 500 lfpm	QFN-32 QFN-32	31 27	°C/W
$\theta_{JC}$	Thermal Resistance (Junction-to-Case) (Note 5)	Standard Board	QFN-32	12	°C/W

Stresses exceeding those listed in the Maximum Ratings table may damage the device. If any of these limits are exceeded, device functionality should not be assumed, damage may occur and reliability may be affected.

4. Maximum ratings applied to the device are individual stress limit values (not normal operating conditions) and not valid simultaneously. If stress limits are exceeded device functional operation is not implied, damage may occur and reliability may be affected.
5. JEDEC standard multilayer board – 2S2P (2 signal, 2 power).

**Table 5. LVCMOS/LVTTL DC CHARACTERISTICS** ( $T_A = -40^\circ\text{C}$  to  $+85^\circ\text{C}$ )

Symbol	Characteristics		Conditions	Min	Typ	Max	Unit
$V_{IH}$	Input High Voltage		$V_{DD} = 3.465\text{ V}$	2.0		$V_{DD} + 0.3$	V
			$V_{DD} = 2.625\text{ V}$	1.7		$V_{DD} + 0.3$	V
			$V_{DD} = 2.0\text{ V}$	$0.65 \times V_{DD}$		$V_{DD} + 0.3$	V
$V_{IL}$	Input Low Voltage		$V_{DD} = 3.465\text{ V}$	-0.3		1.3	V
			$V_{DD} = 2.625\text{ V}$	-0.3		0.7	V
			$V_{DD} = 2.0\text{ V}$	-0.3		$0.35 \times V_{DD}$	V
$I_{IH}$	Input High Current	CLK	$V_{DD} = V_{IN} = 3.465\text{ V}$ or $2.625\text{ V}$ or $2.0\text{ V}$			150	$\mu\text{A}$
		OE, CLK_EN		5			
$I_{IL}$	Input Low Current	CLK	$V_{DD} = 3.465\text{ V}$ or $2.625\text{ V}$ or $2.0\text{ V}$ , $V_{IN} = 0\text{ V}$	-5			$\mu\text{A}$
		OE, CLK_EN		-150			
$V_{OH}$	Output High Voltage (Note 6)		$V_{DDO} = 3.3\text{ V} \pm 5\%$	2.6			V
			$V_{DDO} = 2.5\text{ V} \pm 5\%$	1.8			
			$V_{DDO} = 2.5\text{ V} \pm 5\%$ ; $I_{OH} = -1\text{ mA}$	2.0			
			$V_{DDO} = 1.8\text{ V} \pm 0.2\text{ V}$	$V_{DD} - 0.4$			
			$V_{DDO} = 1.8\text{ V} \pm 0.2\text{ V}$ ; $I_{OH} = -100\ \mu\text{A}$	$V_{DD} - 0.2$			
$V_{OL}$	Output Low Voltage (Note 6)		$V_{DDO} = 3.3\text{ V} \pm 5\%$			0.5	V
			$V_{DDO} = 2.5\text{ V} \pm 5\%$			0.45	
			$V_{DDO} = 2.5\text{ V} \pm 5\%$ ; $I_{OL} = 1\text{ mA}$			0.4	
			$V_{DDO} = 1.8\text{ V} \pm 0.2\text{ V}$			0.35	
			$V_{DDO} = 1.8\text{ V} \pm 0.2\text{ V}$ ; $I_{OL} = 100\ \mu\text{A}$			0.2	

NOTE: Device will meet the specifications after thermal equilibrium has been established when mounted in a test socket or printed circuit board with maintained transverse airflow greater than 500 lfpm.

6. Outputs terminated  $50\ \Omega$  to  $V_{DDO}/2$  unless otherwise specified. See Figure 7.

# NB3V8312C

**Table 6. POWER SUPPLY DC CHARACTERISTICS**, ( $T_A = -40^{\circ}\text{C}$  to  $+85^{\circ}\text{C}$ )

$V_{DD}$ (Core)	$V_{DDO}$ (Outputs)	Min	Typ	Max	Unit
3.3 V $\pm$ 5%	3.3 V $\pm$ 5%			10	mA
3.3 V $\pm$ 5%	2.5 V $\pm$ 5%			10	mA
3.3 V $\pm$ 5%	1.8 V $\pm$ 0.2V			10	mA
2.5 V $\pm$ 5%	2.5 V $\pm$ 5%			10	mA
2.5 V $\pm$ 5%	1.8 V $\pm$ 0.2V			10	mA
1.8 V $\pm$ 0.2 V	1.8 V $\pm$ 0.2V			10	mA

**Table 7. AC CHARACTERISTICS** ( $T_A = -40^{\circ}\text{C}$  to  $+85^{\circ}\text{C}$ ) (Note 7)

Symbol	Characteristic	Min	Typ	Max	Unit
$f_{MAX}$	Maximum Operating Frequency $V_{DD} / V_{DDO}$ 3.3 V $\pm$ 5% / 3.3 V $\pm$ 5% 3.3 V $\pm$ 5% / 2.5 V $\pm$ 5% 3.3 V $\pm$ 5% / 1.8 V $\pm$ 0.2 V 2.5 V $\pm$ 5% / 2.5 V $\pm$ 5% 2.5 V $\pm$ 5% / 1.8 V $\pm$ 0.2 V 1.8 V $\pm$ 0.2 V / 1.8 V $\pm$ 0.2 V	250 250 200 250 200 200			MHz
$t_{pLH}$	Propagation Delay, Low to High; (Note 8) $V_{DD} / V_{DDO}$ 3.3 V $\pm$ 5% / 3.3 V $\pm$ 5% 3.3 V $\pm$ 5% / 2.5 V $\pm$ 5% 3.3 V $\pm$ 5% / 1.8 V $\pm$ 0.2 V 2.5 V $\pm$ 5% / 2.5 V $\pm$ 5% 2.5 V $\pm$ 5% / 1.8 V $\pm$ 0.2 V 1.8 V $\pm$ 0.2 V / 1.8 V $\pm$ 0.2 V	0.9 1.0 1.0 1.3 1.3 2.4		2.2 2.3 3.0 3.1 3.5 4.2	ns
$t_{jit}$	Additive Phase Jitter, RMS; $f_C = 100$ MHz Integration Range: 12 kHz – 20 MHz See Figure 5 $V_{DD} / V_{DDO}$ 3.3 V $\pm$ 5% / 3.3 V $\pm$ 5% 3.3 V $\pm$ 5% / 2.5 V $\pm$ 5% 3.3 V $\pm$ 5% / 1.8 V $\pm$ 0.2 V 2.5 V $\pm$ 5% / 2.5 V $\pm$ 5% 2.5 V $\pm$ 5% / 1.8 V $\pm$ 0.2 V 1.8 V $\pm$ 0.2 V / 1.8 V $\pm$ 0.2 V		30 40 50 20 100 130		fs
$t_{sk(o)}$	Output-to-output skew; (Note 9); Figure 6 $V_{DD} / V_{DDO}$ 3.3 V $\pm$ 5% / 3.3 V $\pm$ 5% 3.3 V $\pm$ 5% / 2.5 V $\pm$ 5% 3.3 V $\pm$ 5% / 1.8 V $\pm$ 0.2 V 2.5 V $\pm$ 5% / 2.5 V $\pm$ 5% 2.5 V $\pm$ 5% / 1.8 V $\pm$ 0.2 V 1.8 V $\pm$ 0.2 V / 1.8 V $\pm$ 0.2 V			125 135 145 150 150 140	ps
$t_{sk(pp)}$	Part-to-Part Skew; (Note 10) $V_{DD} / V_{DDO}$ 3.3 V $\pm$ 5% / 3.3 V $\pm$ 5% 3.3 V $\pm$ 5% / 2.5 V $\pm$ 5% 3.3 V $\pm$ 5% / 1.8 V $\pm$ 0.2 V 2.5 V $\pm$ 5% / 2.5 V $\pm$ 5% 2.5 V $\pm$ 5% / 1.8 V $\pm$ 0.2 V 1.8 V $\pm$ 0.2 V / 1.8 V $\pm$ 0.2 V			250 250 250 250 250 250	ps

All parameters measured at  $f_{MAX}$  unless noted otherwise.

7. Outputs loaded with  $50\ \Omega$  to  $V_{DDO}/2$ ; see Figure 7. CLOCK input with 50% duty cycle; minimum input amplitude = 1.2 V at  $V_{DD} = 3.3$  V, 1.0 V at  $V_{DD} = 2.5$  V,  $V_{DD}/2$  at  $V_{DD} = 1.8$  V.

8. Measured from the  $V_{DD}/2$  of the input to  $V_{DDO}/2$  of the output.

9. Defined as skew between outputs at the same supply voltage and with equal load conditions. Measured at  $V_{DDO}/2$ .

10. Defined as skew between outputs on different devices operating at the same supply voltage and with equal load conditions.

Using the same type of input on each device, the output is measured at  $V_{DDO}/2$ .

11. Clock input with 50% duty cycles, rail-to-rail amplitude and  $t_r/t_f = 500$  ps.

# NB3V8312C

**Table 7. AC CHARACTERISTICS** ( $T_A = -40^\circ\text{C}$  to  $+85^\circ\text{C}$ ) (Note 7) (continued)

Symbol	Characteristic	Min	Typ	Max	Unit
$t_r/t_f$	Output rise and fall times $V_{DD} / V_{DDO}$ 3.3 V $\pm 5\%$ / 3.3 V $\pm 5\%$ 3.3 V $\pm 5\%$ / 2.5 V $\pm 5\%$ 3.3 V $\pm 5\%$ / 1.8 V $\pm 0.2$ V 2.5 V $\pm 5\%$ / 2.5 V $\pm 5\%$ 2.5 V $\pm 5\%$ / 1.8 V $\pm 0.2$ V 1.8 V $\pm 0.2$ V / 1.8 V $\pm 0.2$ V	200 200 200 200 200 200		700 700 700 700 700 800	ps
ODC	Output Duty Cycle (Note 11) $V_{DD} / V_{DDO}$ $f \leq 200$ MHz, 3.3 V $\pm 5\%$ / 3.3 V $\pm 5\%$ $f \leq 150$ MHz, 3.3 V $\pm 5\%$ / 2.5 V $\pm 5\%$ $f \leq 100$ MHz, 3.3 V $\pm 5\%$ / 1.8 V $\pm 0.2$ V $f \leq 150$ MHz, 2.5 V $\pm 5\%$ / 2.5 V $\pm 5\%$ $f \leq 100$ MHz, 2.5 V $\pm 5\%$ / 1.8 V $\pm 0.2$ V $f \leq 100$ MHz, 1.8 V $\pm 0.2$ V / 1.8 V $\pm 0.2$ V	45 45 45 45 45 45		55 55 55 55 55 55	%

All parameters measured at  $f_{MAX}$  unless noted otherwise.

7. Outputs loaded with  $50 \Omega$  to  $V_{DDO}/2$ ; see Figure 7. CLOCK input with 50% duty cycle; minimum input amplitude = 1.2 V at  $V_{DD} = 3.3$  V, 1.0 V at  $V_{DD} = 2.5$  V,  $V_{DD}/2$  at  $V_{DD} = 1.8$  V.

8. Measured from the  $V_{DD}/2$  of the input to  $V_{DDO}/2$  of the output.

9. Defined as skew between outputs at the same supply voltage and with equal load conditions. Measured at  $V_{DDO}/2$ .

10. Defined as skew between outputs on different devices operating at the same supply voltage and with equal load conditions.

Using the same type of input on each device, the output is measured at  $V_{DDO}/2$ .

11. Clock input with 50% duty cycles, rail-to-rail amplitude and  $t_r/t_f = 500$  ps.

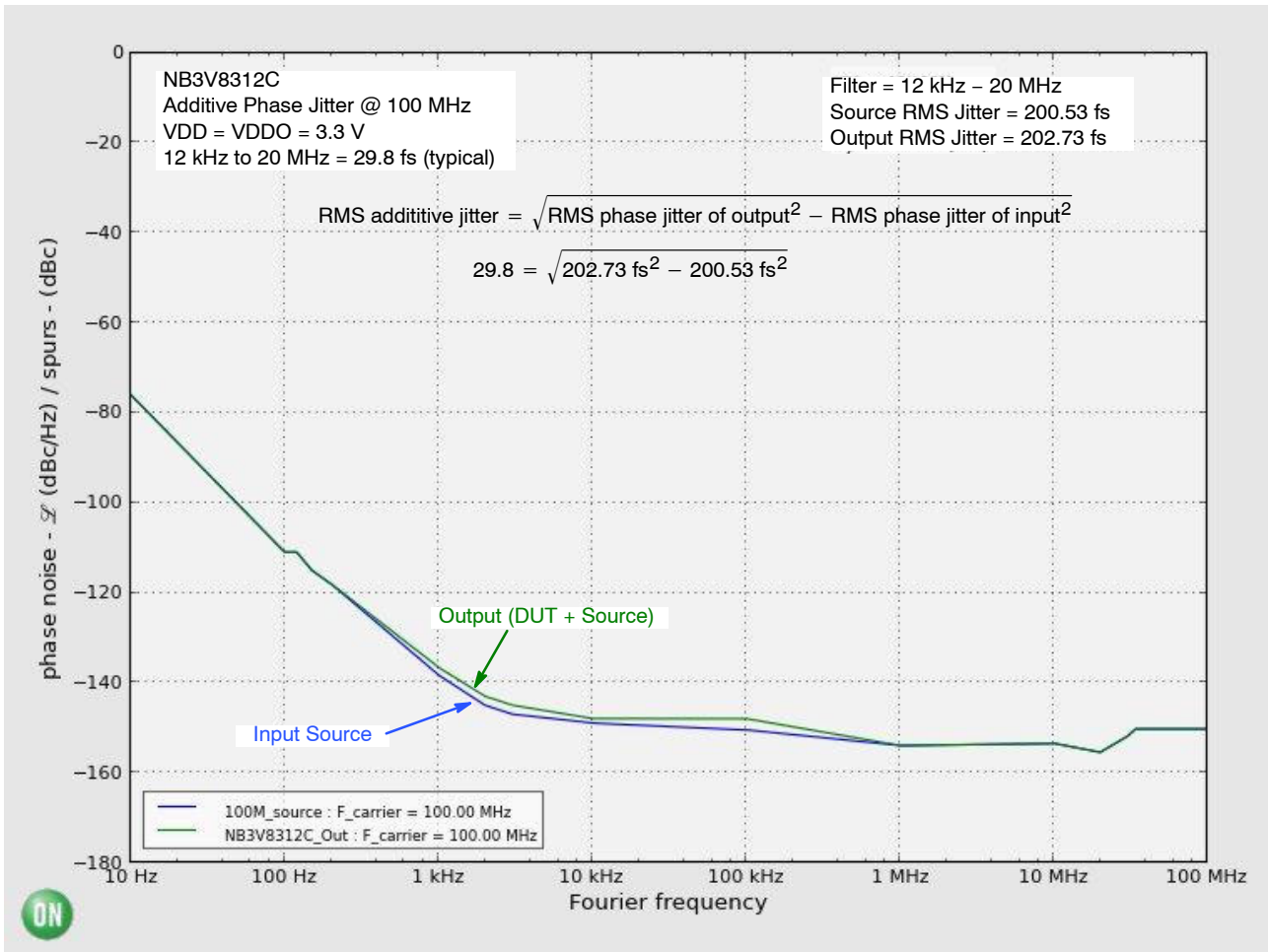

**Figure 5. Typical Phase Noise Plot at  $f_{carrier} = 100$  MHz at an Operating Voltage of 3.3 V, Room Temperature**

## NB3V8312C

The above phase noise data was captured using Agilent E5052A/B. The data displays the input phase noise and output phase noise used to calculate the additive phase jitter at a specified integration range. The RMS Phase Jitter contributed by the device (integrated between 12 kHz and 20 MHz) is 29.8 fs.

The additive phase jitter performance of the fanout buffer is highly dependent on the phase noise of the input source.

To obtain the most accurate additive phase noise measurement, it is vital that the source phase noise be

notably lower than that of the DUT. If the phase noise of the source is greater than the device under test output, the source noise will dominate the additive phase jitter calculation and lead to an artificially low result for the additive phase noise measurement within the integration range. The Figure above is a good example of the NB3V8312C source generator phase noise having a significantly higher floor such that the DUT output results in an additive phase jitter of 29.8 fs.

$$\text{RMS additive jitter} = \sqrt{\text{RMS phase jitter of output}^2 - \text{RMS phase jitter of input}^2}$$

$$29.8 = \sqrt{202.73 \text{ fs}^2 - 200.53 \text{ fs}^2}$$

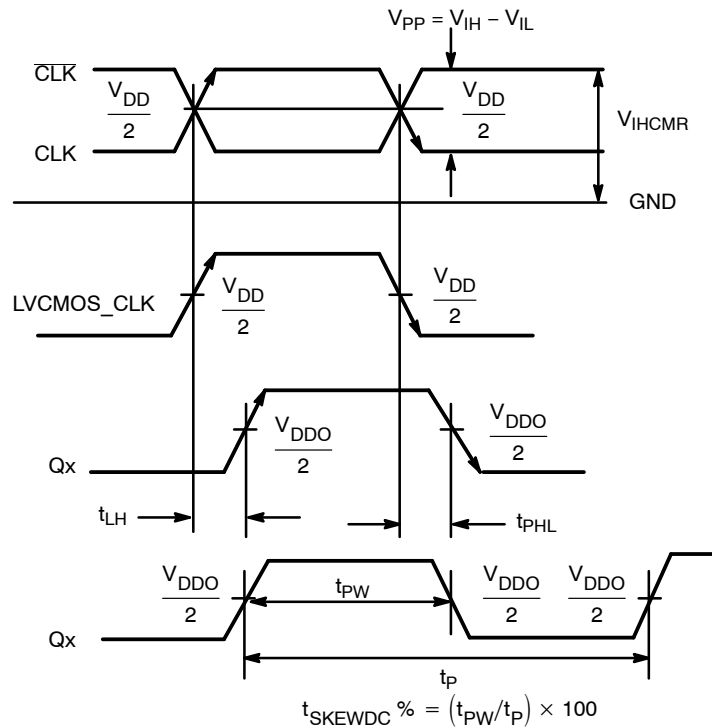

Figure 6. AC Reference Measurement

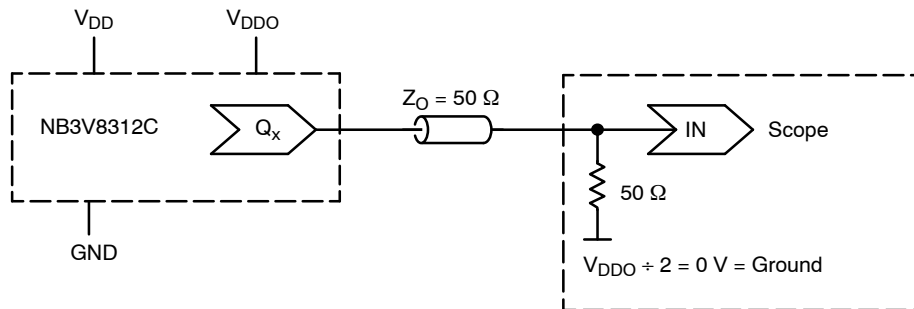

Figure 7. Typical Device Evaluation and Termination Setup – See Table 8

## NB3V8312C

**Table 8. TEST SUPPLY SETUP. V<sub>DDO</sub> SUPPLY MAY BE CENTERED ON 0.0 V (SCOPE GND) TO PERMIT DIRECT CONNECTION INTO “50 Ω TO GND” SCOPE MODULE. V<sub>DD</sub> SUPPLY TRACKS DUT GND PIN**

Spec Condition:	V <sub>DD</sub> Test Setup	V <sub>DDO</sub> Test Setup	GND Pin Test Setup
V <sub>DD</sub> = 3.3 V ±5%, V <sub>DDO</sub> = 3.3 V ±5%	+1.65 ±5%	+1.65 V ±5%	-1.65 V ±5%
V <sub>DD</sub> = 3.3 V ±5%, V <sub>DDO</sub> = 2.5 V ±5%	+2.05 V ±5%	+1.25 V ±5%	-1.25 V ±5%
V <sub>DD</sub> = 3.3 V ±5%, V <sub>DDO</sub> = 1.8 V ±5%	+2.4 V ±5%	+0.9 V ±0.1 V	-0.9 V ±0.1 V
V <sub>DD</sub> = 2.5 V ±5%, V <sub>DDO</sub> = 2.5 V ±5%	+1.25 V ±5%	+1.25 V ±5%	-1.25 V ±5%
V <sub>DD</sub> = 2.5 V ±5%, V <sub>DDO</sub> = 1.8 V ±0.2 V	+1.6 V ±5%	+0.9 V ±0.1 V	-0.9 V ±0.1 V
V <sub>DD</sub> = 1.8 V ±0.2 V, V <sub>DDO</sub> = 1.8 V ±0.2 V	+0.9 V ±0.1 V	+0.9 V ±0.1 V	-0.9 V ±0.1 V



# NB3V8312C

## MARKING DIAGRAMS\*

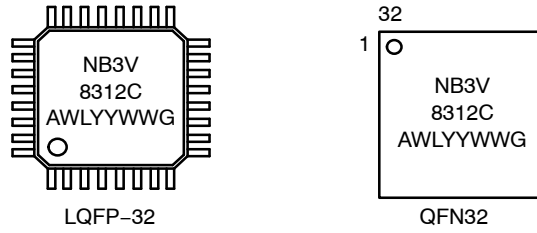

- A = Assembly Location
- WL = Wafer Lot
- YY = Year
- WW = Work Week
- G = Pb-Free Package

(Note: Microdot may be in either location)

\*For additional marking information, refer to Application Note [AND8002/D](#).

## ORDERING INFORMATION

Device	Package	Shipping <sup>†</sup>
NB3V8312CFAG	LQFP-32 (Pb-Free)	250 Units / Tray
NB3V8312CFAR2G	LQFP-32 (Pb-Free)	2000 / Tape & Reel
NB3V8312CMNG	QFN32 (Pb-Free)	74 Units / Tube
NB3V8312CMNR4G	QFN32 (Pb-Free)	1000 / Tape & Reel

<sup>†</sup>For information on tape and reel specifications, including part orientation and tape sizes, please refer to our Tape and Reel Packaging Specifications Brochure, [BRD8011/D](#).

# MECHANICAL CASE OUTLINE

## PACKAGE DIMENSIONS

ON Semiconductor®

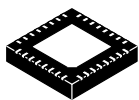

1 32

SCALE 2:1

QFN32 5x5, 0.5P  
CASE 488AM  
ISSUE A

DATE 23 OCT 2013

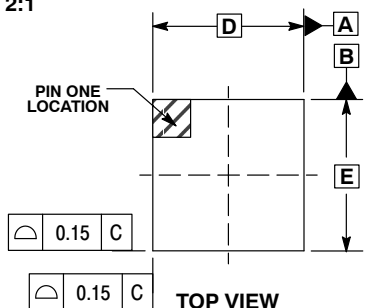

TOP VIEW

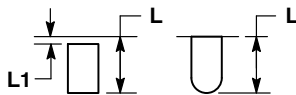

DETAIL A  
ALTERNATE TERMINAL  
CONSTRUCTIONS

NOTES:

1. DIMENSIONS AND TOLERANCING PER ASME Y14.5M, 1994.
2. CONTROLLING DIMENSION: MILLIMETERS.
3. DIMENSION b APPLIES TO PLATED TERMINAL AND IS MEASURED BETWEEN 0.15 AND 0.30MM FROM THE TERMINAL TIP. COPLANARITY APPLIES TO THE EXPOSED PAD AS WELL AS THE TERMINALS.
4. COPLANARITY APPLIES TO THE EXPOSED PAD AS WELL AS THE TERMINALS.

MILLIMETERS		
DIM	MIN	MAX
A	0.80	1.00
A1	---	0.05
A3	0.20	REF
b	0.18	0.30
D	5.00	BSC
D2	2.95	3.25
E	5.00	BSC
E2	2.95	3.25
e	0.50	BSC
K	0.20	---
L	0.30	0.50
L1	---	0.15

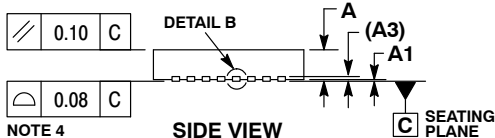

SIDE VIEW

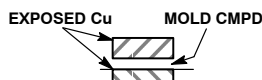

DETAIL B  
ALTERNATE  
CONSTRUCTION

GENERIC  
MARKING DIAGRAM\*

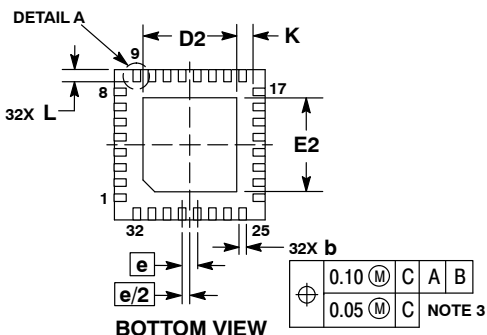

BOTTOM VIEW

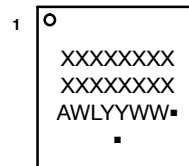

- XXXXX = Specific Device Code
- A = Assembly Location
- WL = Wafer Lot
- YY = Year
- WW = Work Week
- = Pb-Free Package

(Note: Microdot may be in either location)  
\*This information is generic. Please refer to device data sheet for actual part marking.  
Pb-Free indicator, "G" or microdot "▪", may or may not be present.

RECOMMENDED  
SOLDERING FOOTPRINT\*

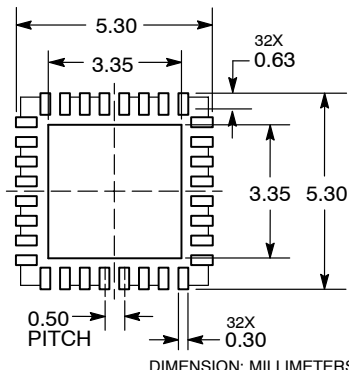

DIMENSION: MILLIMETERS

\*For additional information on our Pb-Free strategy and soldering details, please download the ON Semiconductor Soldering and Mounting Techniques Reference Manual, SOLDERRM/D.

DOCUMENT NUMBER:	98AON20032D	Electronic versions are uncontrolled except when accessed directly from the Document Repository. Printed versions are uncontrolled except when stamped "CONTROLLED COPY" in red.
DESCRIPTION:	QFN32 5x5 0.5P	PAGE 1 OF 1

ON Semiconductor and ON are trademarks of Semiconductor Components Industries, LLC dba ON Semiconductor or its subsidiaries in the United States and/or other countries. ON Semiconductor reserves the right to make changes without further notice to any products herein. ON Semiconductor makes no warranty, representation or guarantee regarding the suitability of its products for any particular purpose, nor does ON Semiconductor assume any liability arising out of the application or use of any product or circuit, and specifically disclaims any and all liability, including without limitation special, consequential or incidental damages. ON Semiconductor does not convey any license under its patent rights nor the rights of others.

**MECHANICAL CASE OUTLINE**  
**PACKAGE DIMENSIONS**

ON Semiconductor®



**LQFP-32, 7x7**  
**CASE 561AB-01**  
**ISSUE O**

DATE 19 JUN 2008

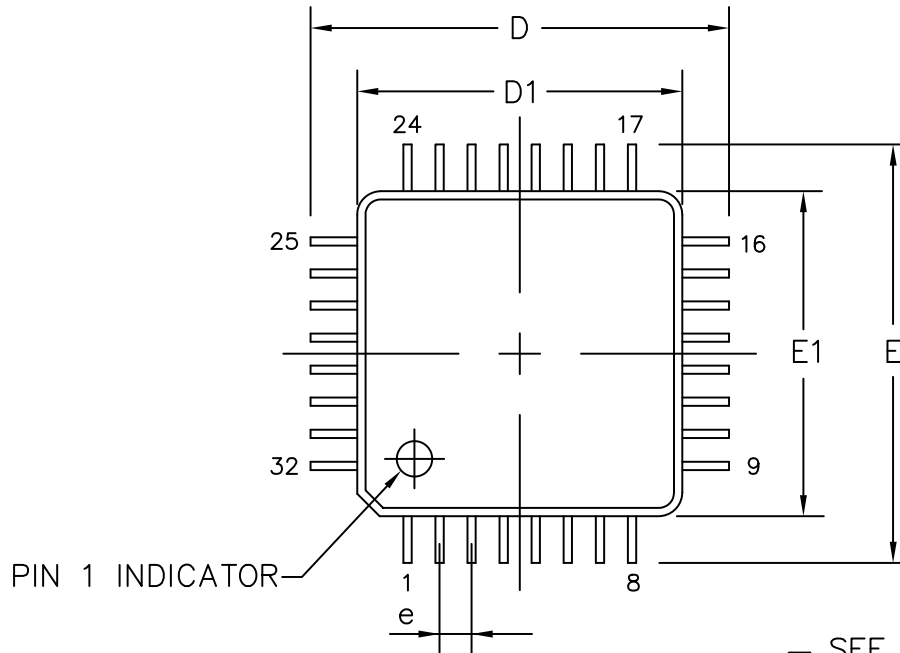

SYMBOL	MIN	NOM	MAX
A	—	—	1.60
A1	0.05	—	0.15
A2	1.35	1.40	1.45
B	0.30	0.37	0.45
B1	0.30	0.35	0.40
C	0.09	—	0.20
C1	0.09	—	0.16
D	9.00 BSC		
D1	7.00 BSC		
E	9.00 BSC		
E1	7.00 BSC		
e	0.80 BSC		
L	0.45	0.60	0.75
L1	1.00		
R1	0.08	—	0.20
$\alpha^\circ$	11	—	13
$\beta^\circ$	0	—	7
$\gamma^\circ$	0	—	—

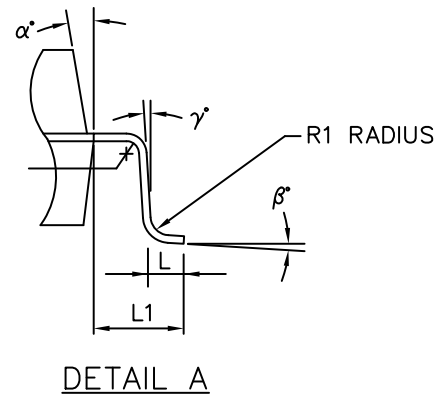
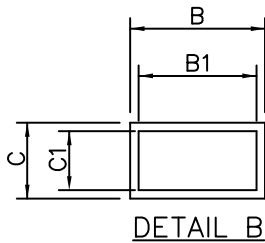
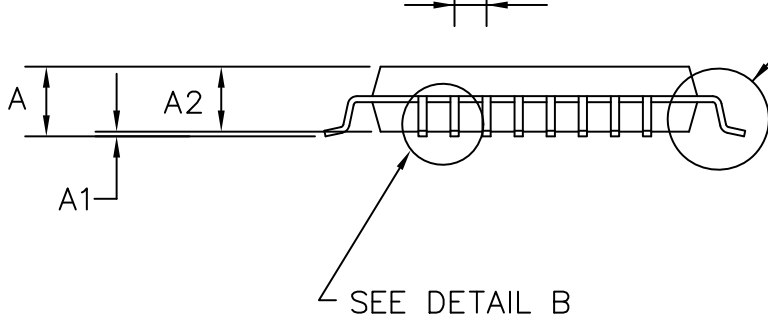

ALL DIMENSIONS IN MM

<b>DOCUMENT NUMBER:</b>	<b>98AON30893E</b>	Electronic versions are uncontrolled except when accessed directly from the Document Repository. Printed versions are uncontrolled except when stamped "CONTROLLED COPY" in red.
<b>DESCRIPTION:</b>	<b>32 LEAD LQFP, 7X7</b>	<b>PAGE 1 OF 1</b>

ON Semiconductor and are trademarks of Semiconductor Components Industries, LLC dba ON Semiconductor or its subsidiaries in the United States and/or other countries. ON Semiconductor reserves the right to make changes without further notice to any products herein. ON Semiconductor makes no warranty, representation or guarantee regarding the suitability of its products for any particular purpose, nor does ON Semiconductor assume any liability arising out of the application or use of any product or circuit, and specifically disclaims any and all liability, including without limitation special, consequential or incidental damages. ON Semiconductor does not convey any license under its patent rights nor the rights of others.

**onsemi**, **Onsemi**, and other names, marks, and brands are registered and/or common law trademarks of Semiconductor Components Industries, LLC dba "**onsemi**" or its affiliates and/or subsidiaries in the United States and/or other countries. **onsemi** owns the rights to a number of patents, trademarks, copyrights, trade secrets, and other intellectual property. A listing of **onsemi**'s product/patent coverage may be accessed at [www.onsemi.com/site/pdf/Patent-Marking.pdf](http://www.onsemi.com/site/pdf/Patent-Marking.pdf). **onsemi** reserves the right to make changes at any time to any products or information herein, without notice. The information herein is provided "as-is" and **onsemi** makes no warranty, representation or guarantee regarding the accuracy of the information, product features, availability, functionality, or suitability of its products for any particular purpose, nor does **onsemi** assume any liability arising out of the application or use of any product or circuit, and specifically disclaims any and all liability, including without limitation special, consequential or incidental damages. Buyer is responsible for its products and applications using **onsemi** products, including compliance with all laws, regulations and safety requirements or standards, regardless of any support or applications information provided by **onsemi**. "Typical" parameters which may be provided in **onsemi** data sheets and/or specifications can and do vary in different applications and actual performance may vary over time. All operating parameters, including "Typicals" must be validated for each customer application by customer's technical experts. **onsemi** does not convey any license under any of its intellectual property rights nor the rights of others. **onsemi** products are not designed, intended, or authorized for use as a critical component in life support systems or any FDA Class 3 medical devices or medical devices with a same or similar classification in a foreign jurisdiction or any devices intended for implantation in the human body. Should Buyer purchase or use **onsemi** products for any such unintended or unauthorized application, Buyer shall indemnify and hold **onsemi** and its officers, employees, subsidiaries, affiliates, and distributors harmless against all claims, costs, damages, and expenses, and reasonable attorney fees arising out of, directly or indirectly, any claim of personal injury or death associated with such unintended or unauthorized use, even if such claim alleges that **onsemi** was negligent regarding the design or manufacture of the part. **onsemi** is an Equal Opportunity/Affirmative Action Employer. This literature is subject to all applicable copyright laws and is not for resale in any manner.

## ADDITIONAL INFORMATION

### TECHNICAL PUBLICATIONS:

Technical Library: [www.onsemi.com/design/resources/technical-documentation](http://www.onsemi.com/design/resources/technical-documentation)  
onsemi Website: [www.onsemi.com](http://www.onsemi.com)

### ONLINE SUPPORT: [www.onsemi.com/support](http://www.onsemi.com/support)

For additional information, please contact your local Sales Representative at [www.onsemi.com/support/sales](http://www.onsemi.com/support/sales)