

# NCP81248

## Three-Rail Controller with Intel Proprietary Interface for IMVP8 CPU Applications

The NCP81248 contains a two-phase, and two single-phase buck regulator controllers optimized for Intel IMVP8 compatible CPUs.

The two-phase controller combines true differential voltage sensing, differential inductor DCR current sensing, input voltage feed-forward, and adaptive voltage positioning to provide accurately regulated power for IMVP8 CPU.

The two single-phase controllers make use of ON Semiconductor's patented high performance RPM operation. RPM control maximizes transient response while allowing smooth transitions between discontinuous frequency scaling operation and continuous mode full power operation. The single-phase rails have a low offset current monitor amplifier with programmable offset compensation for high accuracy current monitoring.

### Features Common to All Rails

- Vin Range 4.5 V to 25 V
- Startup into Pre-Charged Loads While Avoiding False OVP
- Digital Soft Start Ramp
- Adjustable Vboot (except Rail3)
- High Impedance Differential Output Voltage Amplifiers
- Dynamic Reference Injection
- Programmable Output Voltage Slew Rates
- Dynamic VID Feed-Forward
- Differential Current Sense Amplifiers for Each Phase
- Programmable Adaptive Voltage Positioning (AVP)
- Switching Frequency Range of 200 kHz –1.2 MHz
- Digitally Stabilized Switching Frequency
- UltraSonic Operation

### Two-phase Rail Features

- Supports Intel proprietary interface Addresses 00 and 01
- Current Mode Dual Edge Modulation for Fastest Initial Response to Transient Loading
- High Performance Operational Error Amplifier
- Accurate Total Summing Current Amplifier
- Phase-to-Phase Dynamic Current Balancing
- Power Saving Phase Shedding



ON Semiconductor®

[www.onsemi.com](http://www.onsemi.com)

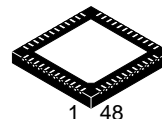

QFN48  
CASE 485BA

### MARKING DIAGRAM

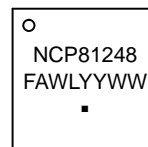

NCP81243 = Specific Device Code  
F = Wafer Fab Code  
A = Assembly Location  
WL = Wafer Lot  
YY = Year  
WW = Work Week  
▪ = Pb-Free Package

### ORDERING INFORMATION

Device	Package	Shipping
NCP81248MNTXG	QFN48 (Pb-Free)	2500 / Tape & Reel

†For information on tape and reel specifications, including part orientation and tape sizes, please refer to our Tape and Reel Packaging Specifications Brochure, BRD8011/D.

### Single-phase Rail Features

- Supports Intel proprietary interface Addresses 00, 01, 02 and 03
- High Performance RPM Control System
- Low Offset IOUT Monitor
- Zero Droop Capable

### Other Features

- PSYS Input Monitor
- Thermal Monitors for Three Intel proprietary interface Addresses
- These Devices are Pb-Free, Halogen Free/BFR Free and are RoHS Compliant

# NCP81248

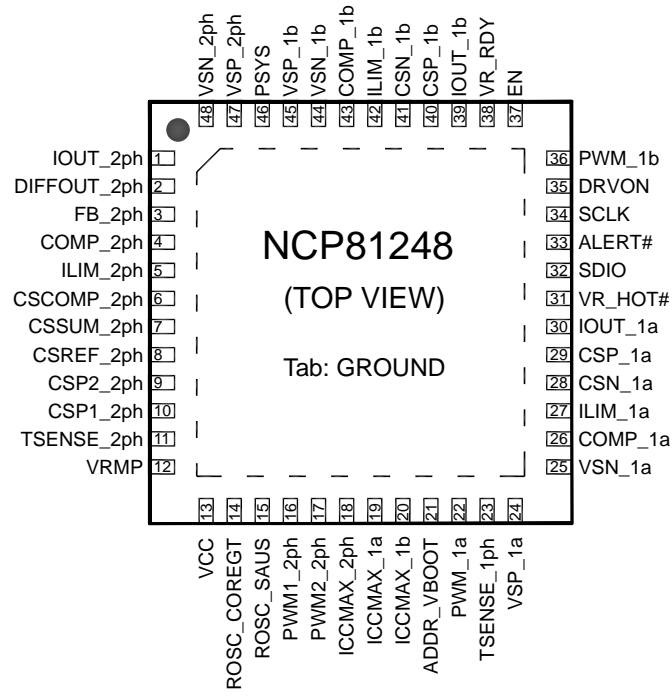

Figure 1.

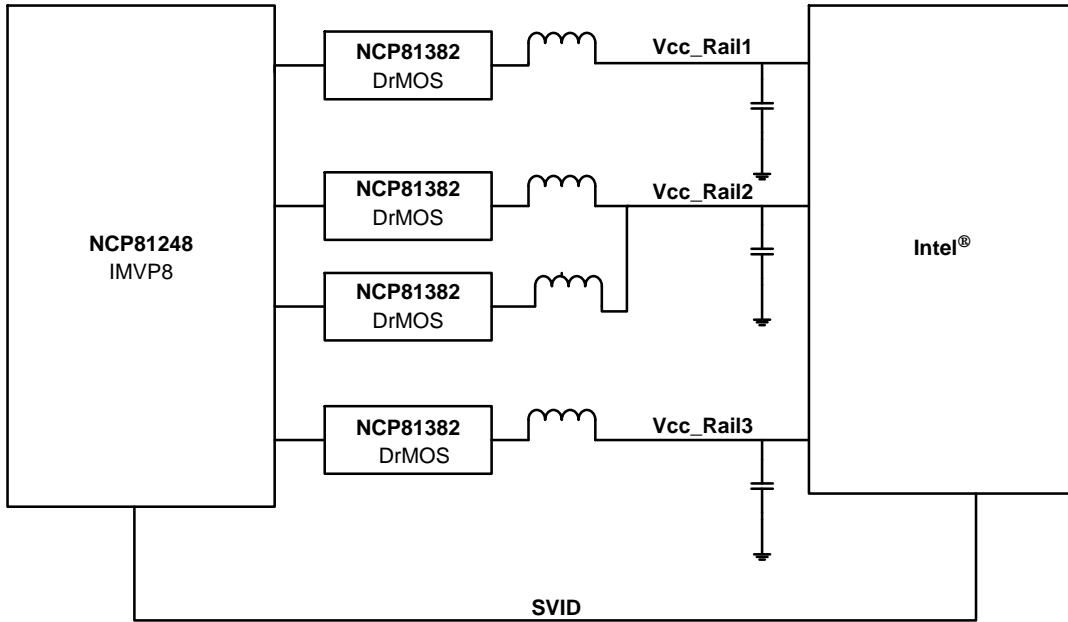

Figure 2. Typical DrMOS Application Diagram

# NCP81248

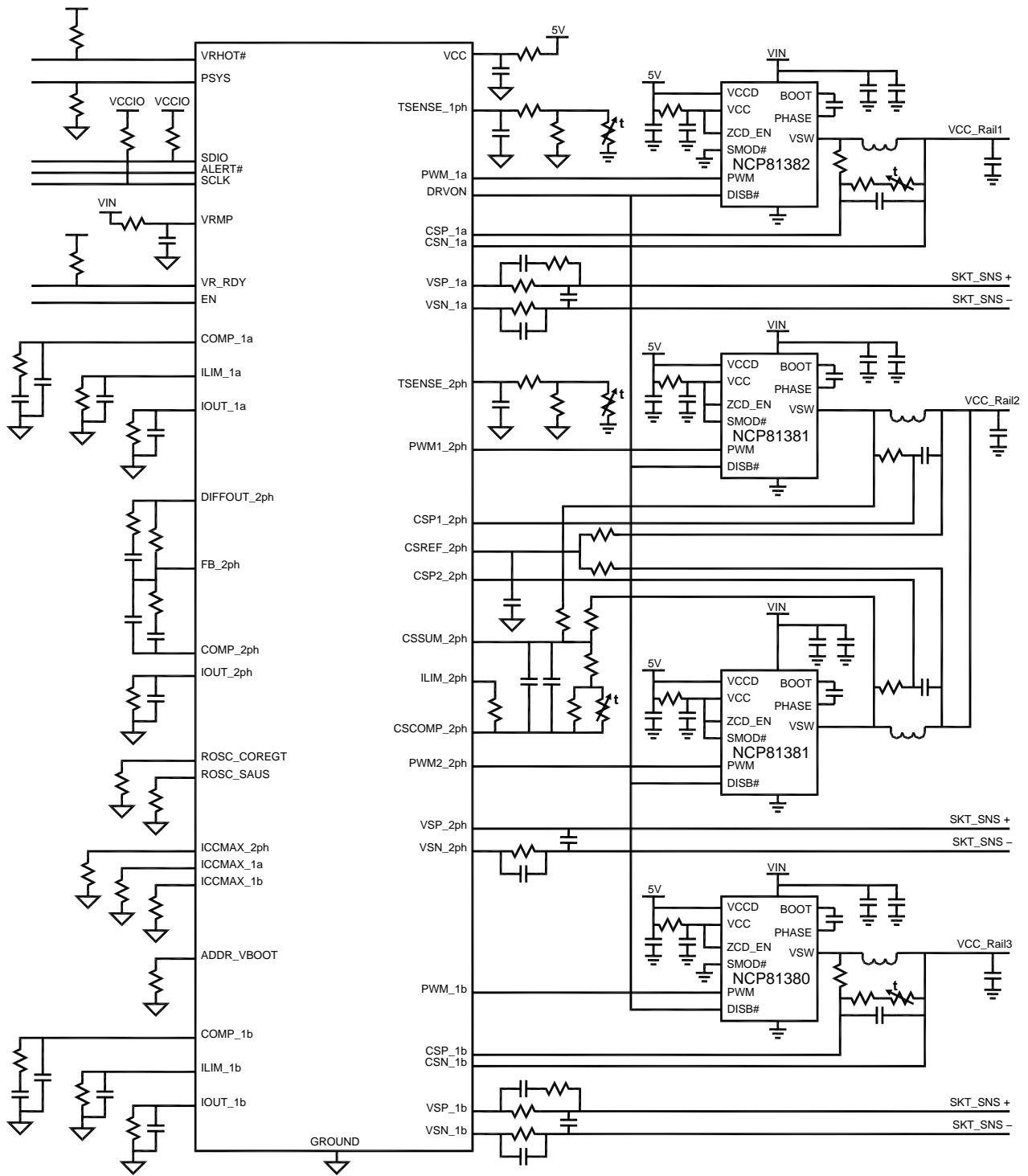

Figure 3. Application Schematic

# NCP81248

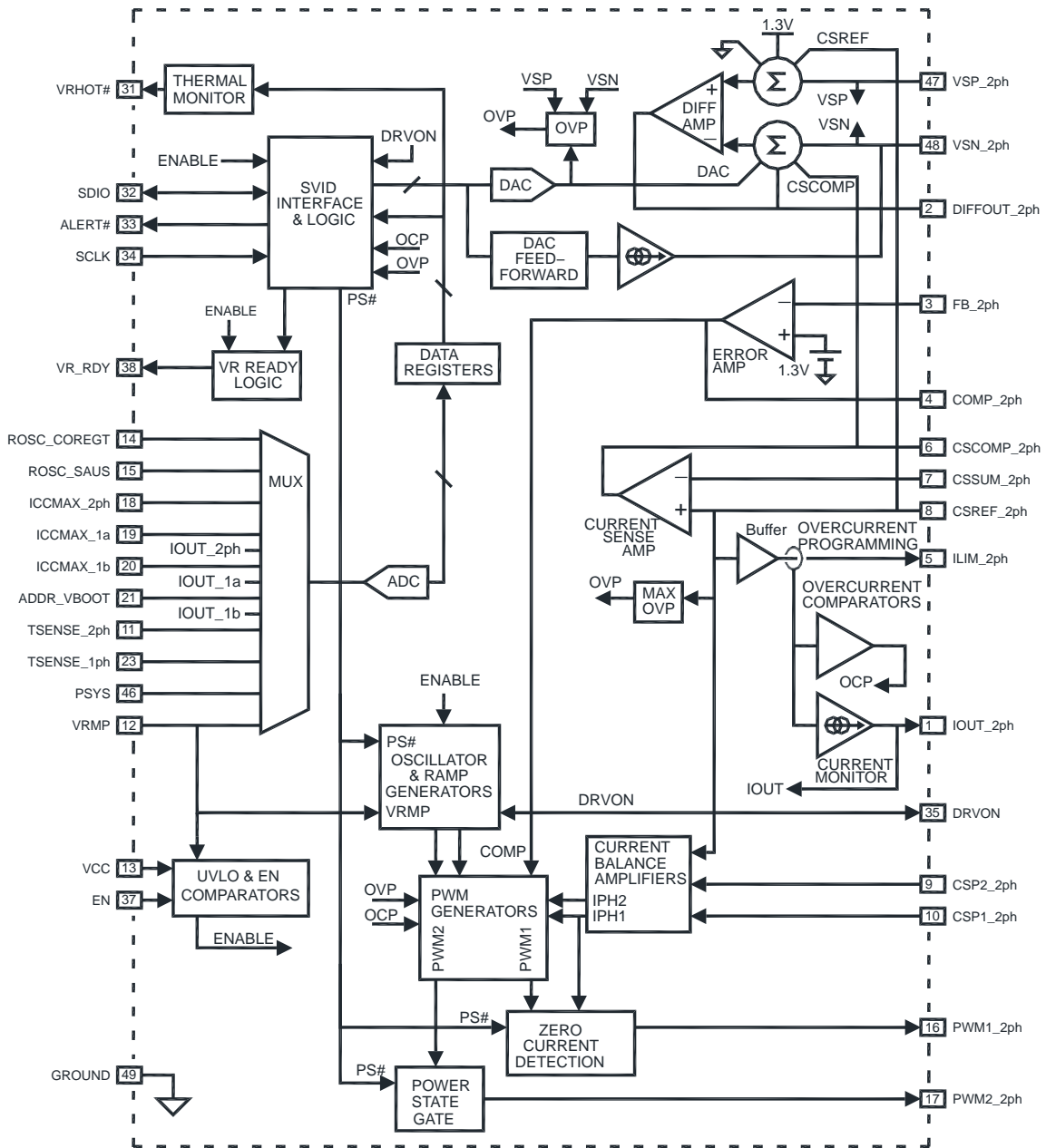

Figure 4. 2-Phase Rail Block Diagram

# NCP81248

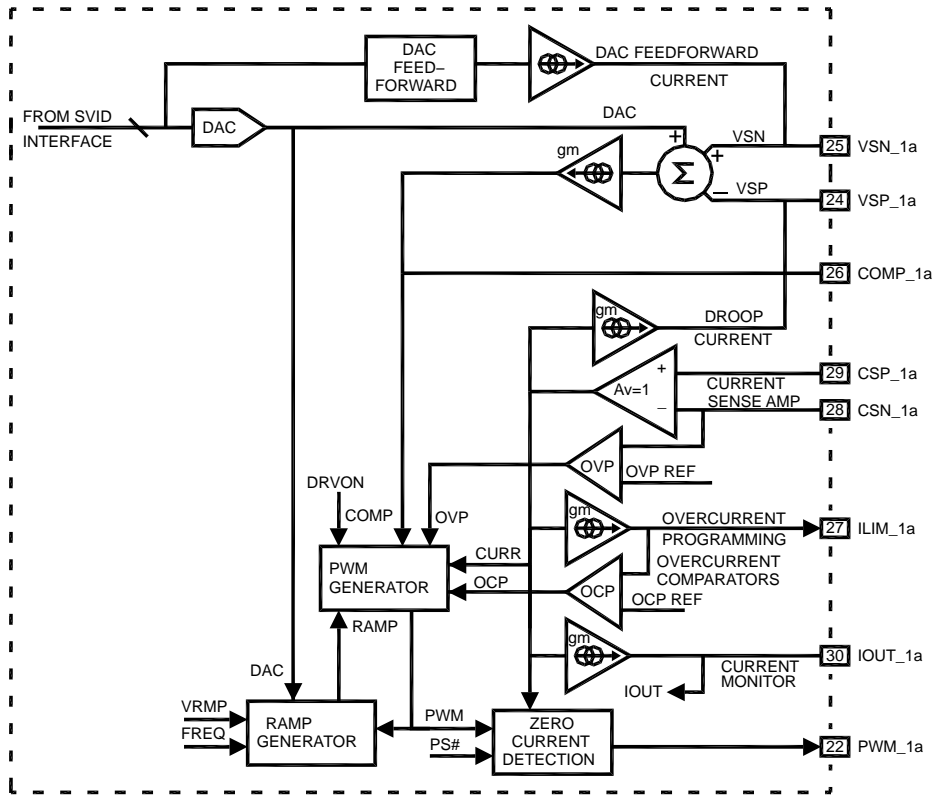

Figure 5. Single Phase "a" Block Diagram

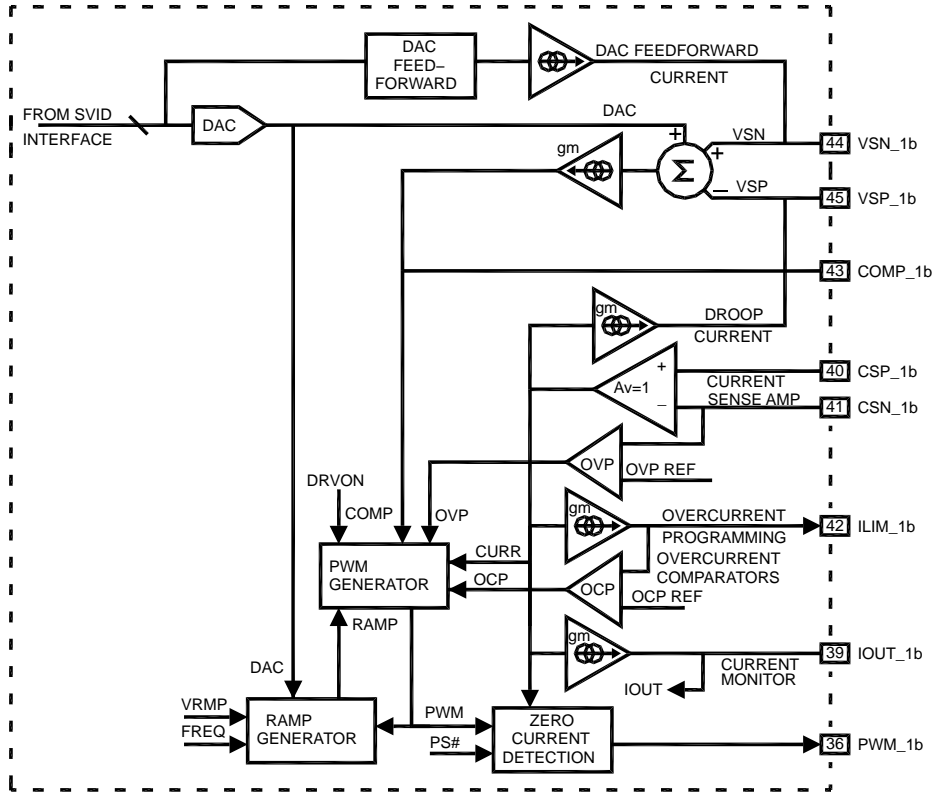

Figure 6. Single Phase "b" Block Diagram

# NCP81248

**Table 1. NCP81248 PIN DESCRIPTIONS**

Pin No.	Symbol	Description
1	IOUT_2ph	IOUT gain programming pin for the 2-phase regulator
2	DIFFOUT_2ph	Output of the 2-phase regulator's output differential remote sense amplifier
3	FB_2ph	Error amplifier voltage feedback input for the 2-phase regulator
4	COMP_2ph	Output of the error amplifier and the inverting inputs of PWM comparators for the two-phase regulator
5	ILIM_2ph	Over-current monitor input for the 2-phase regulator -- programmed with a resistor to CSCOMP_2ph
6	CSCOMP_2ph	Output of total-current-sense amplifier for the 2-phase regulator
7	CSSUM_2ph	Inverting input of total-current-sense amplifier for the 2-phase regulator
8	CSREF_2ph	Total-current-sense amplifier reference voltage input for the 2-phase regulator
9	CSP2_2ph	Non-inverting input to 2-phase regulator Phase 2 current-balance amplifier
10	CSP1_2ph	Non-inverting input to 2-phase regulator Phase 1 current-balance amplifier
11	TSENSE_2ph	Temperature sense input for the 2-phase regulator (see Rail Configuration Table)
12	VRMP	VIN Feed-forward input for compensating modulator ramp-slopes. The current fed into this pin is used to control the ramp of the PWM slopes. Also, the input monitoring VIN for undervoltage (UVLO)
13	VCC	Power for the internal control circuits. A decoupling capacitor must be connected from this pin to ground
14	ROSC_COREGT	Switching frequency program input for rails configured as Rail1 and Rail2
15	ROSC_SAUS	Switching frequency program input for the 1-phase rail configured as Rail3
16	PWM1_2ph	2-phase regulator Phase 1 PWM output
17	PWM2_2ph	2-phase regulator Phase 2 PWM output
18	ICCMAX_2ph	During startup, the IccMax of the 2-phase regulator is programmed by a pull-down resistor on this pin
19	ICCMAX_1a	During startup, the ICCMAX of 1-phase Regulator 1a is programmed by a pulldown resistor on this pin
20	ICCMAX_1b	During startup, the ICCMAX of 1-phase Regulator 1b is programmed by a pulldown resistor on this pin
21	ADDR_VBOOT	During startup, a resistor to GND programs Intel proprietary interface addresses and VBOOT options for all three rails
22	PWM_1a	1-phase regulator 1a PWM output
23	TSENSE_1ph	Temperature sense input for 1-phase regulator. (see Rail Configuration Table)
24	VSP_1a	Positive input of 1-phase regulator 1a differential output voltage sense amplifier
25	VSN_1a	Negative input of 1-phase regulator 1a differential output voltage sense amplifier
26	COMP_1a	Compensation for 1-phase regulator 1a
27	ILIM_1a	Current-limit for 1-phase regulator 1a is programmed by a pull-down resistor on this pin
28	CSN_1a	Negative input of 1-phase regulator 1a differential current sense amplifier
29	CSP_1a	Positive input of 1-phase regulator 1a differential current sense amplifier Pull this pin to VCC to disable 1-phase regulator 1a
30	IOUT_1a	IOUT gain programming pin for 1-phase regulator 1a
31	VR_HOT#	Open drain output for an over-temperature condition detected on any TSENSE input
32	SDIO	Serial VID data interface
33	ALERT#	Serial VID ALERT#
34	SCLK	Serial VID clock
35	DRVON	Enable output for external discrete FET drivers and/or ON Semiconductor DrMOS.
36	PWM1b	1-phase regulator 1b PWM output

# NCP81248

**Table 1. NCP81248 PIN DESCRIPTIONS**

Pin No.	Symbol	Description
37	EN	Enable. High activates all configured rails
38	VR_RDY	Open drain output. High indicates all three rails are ready to accept Intel proprietary interface commands
39	IOUT_1b	IOUT gain programming pin for 1-phase regulator 1b
40	CSP_1b	Positive input of 1-phase regulator 1b differential current sense amplifier Pull this pin to VCC to disable 1-phase regulator 1b
41	CSN_1b	Negative input of 1-phase regulator 1b differential current sense amplifier
42	ILIM_1b	Current-limit for 1-phase regulator 1b is programmed by a pull-down resistor on this pin
43	COMP_1b	Compensation for 1-phase regulator 1b
44	VSN_1b	Negative input of 1-phase regulator 1b differential output voltage sense amplifier
45	VSP_1b	Positive input of 1-phase regulator 1b differential output voltage sense amplifier
46	PSYS	System power signal input. Resistor to ground needed for scaling. When the NCP81248 is configured with a Rail4, this input is a temperature monitor. (see Rail Configuration Table)
47	VSP_2ph	Positive input of 2-phase regulator differential output voltage sense amplifier
48	VSN-2ph	Negative input of 2-phase regulator differential output voltage sense amplifier

**Table 2. MAXIMUM RATINGS**

Rating	Symbol	Min	Max	Unit
Pin Voltage Range (Note 1)	VSN_x	-0.3	+0.3	V
Pin Voltage Range (Note 1)	VCC	-0.3	6.5	V
Pin Voltage Range (Note 1)	IOUT_x	-0.3	2.5	V
Pin Voltage Range (Note 1)	VRMP	-0.3	+25	V
Pin Voltage Range (Note 1)	All Other Pins	-0.3	VCC + 0.3	V
Junction Temperature	T <sub>J(max)</sub>	-40	125	°C
Operating Ambient Temperature	T <sub>J(OP)</sub>	-40	100	°C
Storage Temperature Range	T <sub>STG</sub>	-40	150	°C
Moisture Sensitivity Level QFN Package	MSL	1		-
Lead Temperature Soldering Reflow (SMD Styles Only), Pb-Free Versions (Note 3)	T <sub>SLD</sub>		260	°C

Stresses exceeding those listed in the Maximum Ratings table may damage the device. If any of these limits are exceeded, device functionality should not be assumed, damage may occur and reliability may be affected.

- All signals referenced to GND unless noted otherwise.
- This device series incorporates ESD protection and is tested by the following methods:  
ESD Human Body Model tested per AEC-Q100-002 (EIA/JESD22-A114)  
ESD Machine Model tested per AEC-Q100-003 (EIA/JESD22-A115)  
Latchup Current Maximum Rating: ≤150 mA per JEDEC standard: JESD78
- For information, please refer to our Soldering and Mounting Techniques Reference Manual, SOLDERRM/D.
- Pin ratings referenced to VCC apply with VCC at any voltage within the VCC Pin Voltage Range.

# NCP81248

**Table 3. THERMAL CHARACTERISTICS**

Rating	Symbol	Value	Unit
Thermal Characteristic QFN Package (Note 5)	$R_{\theta JA}$	68	°C/W
Thermal Characteristic QFN Package (Note 5)	$R_{\theta JC}$	8	°C/W

5. JESD 51-5 (1S2P Direct-Attach Method) with 0 LFM

**Table 4. ELECTRICAL CHARACTERISTICS – ELEMENTS COMMON TO SINGLE & 2-PHASE RAILS** ( $V_{CC} = 5.0\text{ V}$ ,  $V_{EN} = 2.0\text{ V}$ ,  $C_{VCC} = 0.1\ \mu\text{F}$  unless specified otherwise) Min/Max values are valid for the temperature range  $-40^{\circ}\text{C} \leq T_A \leq 100^{\circ}\text{C}$  unless noted otherwise, and are guaranteed by test, design or statistical correlation.

Parameter	Symbol	Test Conditions	Min	Typ	Max	Unit
-----------	--------	-----------------	-----	-----	-----	------

**VCC INPUT SUPPLY**

Supply Voltage Range			4.75		5.25	V
Quiescent Current		EN = high, $T_A = 100^{\circ}\text{C}$		28	32	mA
		EN = low, $T_A = 25^{\circ}\text{C}$		30	50	$\mu\text{A}$
UVLO Threshold		VCC rising			4.5	V
		VCC falling	4			V
UVLO Hysteresis (Note 6)			180	290		mV

**VRMP**

UVLO Threshold		VRMP Rising		3.95	4.25	V
		VRMP Falling	3	3.24		V
UVLO Hysteresis (Note 6)			500	710		mV
Ramp Feed-forward Control Range		Range in which the ramp slope is affected by VRMP voltage	5		20	V

**ENABLE INPUT**

Enable High Input Leakage Current		External 1k pull-up to 3.3 V			1.0	$\mu\text{A}$
Activation Level		$V_{UPPER}$	0.8			V
Deactivation Level		$V_{LOWER}$			0.3	V
Total Hysteresis (Note 6)		$V_{RISING} - V_{FALLING}$		295		mV
Enable Delay Time – Rising		Time from Enable transitioning HIGH to DRVON going HIGH	1.0	2.1	2.5	ms
Enable Delay Time – Falling (Note 6)		Time from Enable transitioning LOW to DRVON below 0.8 V		190		ns

**PHASE DETECTION**

CSP Pin Pulldown Current (Note 6)		Pulldown applied only prior to softstart		20		$\mu\text{A}$
CSP Pin Threshold voltage			4.5			V
Phase Detect Timer (Note 6)				1.8		ms

**DAC SLEW RATE**

Soft Start Slew Rate				15		mV/ $\mu\text{s}$
Slew Rate Slow				15		mV/ $\mu\text{s}$
Slew Rate Fast				30		mV/ $\mu\text{s}$

**DRVON**

Output High Voltage		Sourcing 500 $\mu\text{A}$	3.0			V
Output Low Voltage		Sinking 500 $\mu\text{A}$			0.1	V



# NCP81248

**Table 4. ELECTRICAL CHARACTERISTICS – ELEMENTS COMMON TO SINGLE & 2-PHASE RAILS** ( $V_{CC} = 5.0\text{ V}$ ,  $V_{EN} = 2.0\text{ V}$ ,  $C_{VCC} = 0.1\ \mu\text{F}$  unless specified otherwise) Min/Max values are valid for the temperature range  $-40^{\circ}\text{C} \leq T_A \leq 100^{\circ}\text{C}$  unless noted otherwise, and are guaranteed by test, design or statistical correlation.

Parameter	Symbol	Test Conditions	Min	Typ	Max	Unit
<b>DRVON</b>						
Rise Time		CL (PCB) = 20 pF, $\Delta V_o = 10\%$ to 90%		150		ns
Fall Time				2.5		
Internal Pull Up Resistance				2.5		k $\Omega$
Internal Pull Down Resistance		EN = Low		50		k $\Omega$
<b>PWM OUTPUTS</b>						
Output High Voltage		Sourcing 500 $\mu\text{A}$	$V_{CC} - 0.2\text{V}$			V
Output Mid Voltage		PS2, No Load	1.9	2.0	2.1	V
Output Low Voltage		Sinking 500 $\mu\text{A}$			0.7	V
Rise and Fall Time (Note 6)		CL (PCB) = 50 pF, $\Delta V_o = 10\%$ to 90%		8		ns
<b>VR_RDY OUTPUT</b>						
Output Low Saturation Voltage		$I_{VR\_RDY} = 4\text{ mA}$			0.3	V
Rise Time		External pull-up of 1 k $\Omega$ to 3.3 V $C_{TOT} = 45\text{ pF}$ , $\Delta V_o = 10\%$ to 90%		120		ns
Fall Time		External pull-up of 1 k $\Omega$ to 3.3 V $C_{TOT} = 45\text{ pF}$ , $\Delta V_o = 90\%$ to 10%		25		ns
Output Leakage Current When High		$VR\_RDY = 5.0\text{ V}$	-1.0		1.0	$\mu\text{A}$
<b>VR_HOT#</b>						
Output Low Voltage		$I_{VRHOT} = 4\text{ mA}$			0.3	V
Output Leakage Current		High Impedance State	-1.0		1.0	$\mu\text{A}$
<b>ADC</b>						
Linear Input Voltage Range			0		2.00	V
Differential Nonlinearity (DNL)		Highest 8-bits			1	LSB
Conversion Time				7.4		$\mu\text{s}$
Conversion Rate				136		kHz
Total Unadjusted Error (TUE)			-1.25		+1.25	%
Power Supply Sensitivity				$\pm 1$		%
Round Robin Time				59		$\mu\text{s}$

Product parametric performance is indicated in the Electrical Characteristics for the listed test conditions, unless otherwise noted. Product performance may not be indicated by the Electrical Characteristics if operated under different conditions.

6. Guaranteed by design or characterization data. Not tested in production.

# NCP81248

**Table 5. ELECTRICAL CHARACTERISTICS – TWO PHASE REGULATOR** ( $V_{CC} = 5.0\text{ V}$ ,  $V_{EN} = 2.0\text{ V}$ ,  $C_{VCC} = 0.1\ \mu\text{F}$  unless specified otherwise) Min/Max values are valid for the temperature range  $-40^{\circ}\text{C} \leq T_A \leq 100^{\circ}\text{C}$  unless noted otherwise, and are guaranteed by test, design or statistical correlation.

Parameter	Symbol	Test Conditions	Min	Typ	Max	Unit
<b>DIFFERENTIAL SUMMING AMPLIFIER</b>						
Input Bias Current – VSP		$V_{SP} = 1.3\text{ V}$	-1		1	$\mu\text{A}$
Input Bias Current – VSN		$V_{SN} = 0\text{ V}$	-25		25	nA
VSP Input Voltage Range			-0.3		3.0	V
VSN Input Voltage Range			-0.3		0.3	V
-3 dB Bandwidth (Note 7)		$C_L = 20\text{ pF to GND}$ , $R_L = 10\text{ k}\Omega\text{ to GND}$		18		MHz
Closed Loop DC gain		$V_{VSP} - V_{VSN} = 0.5\text{ to }1.3\text{ V}$		1.0		V/V
<b>ERROR AMPLIFIER</b>						
Input Bias Current		$V_{FB} = 1.3\text{ V}$	-400		400	nA
Open Loop DC Gain (Note 7)		$C_L = 20\text{ pF to GND}$ , $R_L = 10\text{ k}\Omega\text{ to GND}$		80		dB
Open Loop Unity Gain Bandwidth (Note 7)		$C_L = 20\text{ pF to GND}$ , $R_L = 10\text{ k}\Omega\text{ to GND}$		20		MHz
Slew Rate (Note 7)		$\Delta V_{in} = 100\text{ mV}$ , $G = -10\text{V/V}$ , $\Delta V_{out} = 1.5\text{ V} - 2.5\text{V}$ , $C_L = 20\text{ pF to GND}$ , DC Load = 10k to GND		30		V/ $\mu\text{s}$
Maximum Output Voltage		$I_{SOURCE} = 2.0\text{ mA}$	3.5			V
Minimum Output Voltage		$I_{SINK} = 2.0\text{ mA}$			1	V
<b>CURRENT SUMMING AMPLIFIER</b>						
Offset Voltage (Note 7)	$V_{OS}$		-375		375	$\mu\text{V}$
Input Bias Current		$V_{CSSUM} = V_{CSREF} = 1\text{ V}$	-7.5		7.5	nA
Open Loop Gain (Note 7)				80		dB
Unity Gain Bandwidth (Note 7)		$C_L = 20\text{ pF to GND}$ , $R_L = 10\text{ k}\Omega\text{ to GND}$		10		MHz
Maximum CSCOMP Output Voltage		$I_{source} = 2\text{ mA}$	3.5			V
Minimum CSCOMP Output Voltage		$I_{sink} = 500\ \mu\text{A}$			100	mV
		$I_{sink} = 25\ \mu\text{A}$		7	30	mV
<b>CURRENT BALANCE AMPLIFIERS</b>						
Input Bias Current		$V_{CSP1} = V_{CSP2} = V_{CSREF} = 1.2\text{ V}$	-50		50	nA
Common Mode Input Voltage Range		$V_{CSP1} = V_{CSP2} = V_{CSREF}$	0		2.3	V
Differential Input Voltage Range		$V_{CSREF} = 1.2\text{ V}$	-100		100	mV
Input Offset Voltage Matching		$V_{CSP1} = V_{CSP2} = V_{CSREF} = 1.2\text{ V}$ Deviation from average offset	-1.5		1.5	mV
Current Sense Amplifier Gain		$0\text{ V} < V_{CSPX} - V_{CSREF} < 0.1\text{ V}$	5.7	6.0	6.3	V/V
Current Sense Gain Matching		$10\text{ mV} < V_{CSPX} - V_{CSREF} < 30\text{ mV}$	-4		4	%
-3 dB Bandwidth (Note 7)				8		MHz
<b>IOUT OUTPUT</b>						
Input Referred Offset Voltage		ILIM to CSREF	-2.75		2.75	mV
Output Source Current		ILIM sink current = 20 $\mu\text{A}$	190			$\mu\text{A}$
Current Gain		$I_{IOUT} / I_{ILIM}$ ; $R_{ILIM} = 20\text{k}$ , $R_{IOUT} = 5.0\text{k}$ , DAC = 0.8 V, 1.25 V, 1.52V	9.5	10	10.5	$\mu\text{A}/\mu\text{A}$

# NCP81248

**Table 5. ELECTRICAL CHARACTERISTICS – TWO PHASE REGULATOR** ( $V_{CC} = 5.0\text{ V}$ ,  $V_{EN} = 2.0\text{ V}$ ,  $C_{VCC}=0.1\ \mu\text{F}$  unless specified otherwise) Min/Max values are valid for the temperature range  $-40^{\circ}\text{C} \leq T_A \leq 100^{\circ}\text{C}$  unless noted otherwise, and are guaranteed by test, design or statistical correlation.

Parameter	Symbol	Test Conditions	Min	Typ	Max	Unit
<b>OVERCURRENT PROTECTION</b>						
ILIM Threshold Current (delayed OCP shutdown)	$I_{CL0}$		9.0	10	11	$\mu\text{A}$
	$I_{CL1}$			6.7		$\mu\text{A}$
ILIM Threshold Current (immediate OCP shutdown)	$I_{CLM0}$		13.5	15	16.5	$\mu\text{A}$
	$I_{CLM1}$			10		$\mu\text{A}$
Shutdown Delay (immediate)				300		ns
Shutdown Delay (delayed)	$t_{OCPDLY}$			50		$\mu\text{s}$
ILIM Offset Voltage		$V_{ILIM} - V_{CSREF}$ ; ILIM sourcing 15 $\mu\text{A}$	-2		2	mV
<b>OUTPUT OVER VOLTAGE &amp; UNDER VOLTAGE PROTECTION (OVP &amp; UVP)</b>						
Absolute Over Voltage Threshold	$V_{OVABS2}$	CSREF voltage during softstart		2		V
Over Voltage Threshold Above DAC	$V_{OVP2}$	$V_{VSP} - V_{VSN} - VID$ rising	365		430	mV
Over Voltage Delay (Note 7)		$V_{VSP} - V_{VSN}$ rising to PWM low		25		ns
Under Voltage	$V_{UVM}$	$V_{VSP} - V_{VSN} - VID$ falling	-370	-295	-225	mV
Under-voltage Delay (Note 7)		$V_{VSP} - V_{VSN}$ falling to VR_RDY falling		5		$\mu\text{s}$
<b>OSCILLATOR</b>						
Switching Frequency Range			200	-	1200	kHz
<b>MODULATORS (PWM Comparators)</b>						
0% Duty Cycle		COMP voltage when the PWM outputs remain LO		1.3		V
100% Duty Cycle		COMP voltage when the PWM outputs remain HI VRMP = 12.0 V		2.5		V
PWM Phase Angle Error				$\pm 15$		deg
<b>TSENSE_2ph</b>						
Alert# Assert Threshold		25°C to 100°C		488		mV
Alert# De-assert Threshold		25°C to 100°C		510		mV
VRHOT Assert Threshold		25°C to 100°C		469		mV
VRHOT Rising Threshold		25°C to 100°C		489		mV
Bias Current		25°C to 100°C	116	120	124	$\mu\text{A}$
<b>ICCMAX PIN</b>						
Bias Current	$I_{MXBIAS2}$	Applied only after enabling, and prior to softstart.	9.63	9.98	10.32	$\mu\text{A}$

Product parametric performance is indicated in the Electrical Characteristics for the listed test conditions, unless otherwise noted. Product performance may not be indicated by the Electrical Characteristics if operated under different conditions.

7. Guaranteed by design or characterization data. Not tested in production.

# NCP81248

**Table 6. ELECTRICAL CHARACTERISTICS – SINGLE PHASE REGULATORS** ( $V_{CC} = 5.0\text{ V}$ ,  $V_{EN} = 2.0\text{ V}$ ,  $C_{VCC} = 0.1\ \mu\text{F}$  unless specified otherwise) Min/Max values are valid for the temperature range  $-40^{\circ}\text{C} \leq T_A \leq 100^{\circ}\text{C}$  unless noted otherwise, and are guaranteed by test, design or statistical correlation.

Parameter	Symbol	Test Conditions	Min	Typ	Max	Unit
<b>ERROR AMPLIFIER</b>						
Input Bias Current		VSP – see DROOP OUTPUT				
		VSN	-25		25	nA
VSP Input Voltage Range			-0.3		3.0	V
VSN Input Voltage Range			-0.3		0.3	V
Gain	$gm_{EA}$		1.2	1.6	1.9	mS
Input Offset			-500		500	$\mu\text{V}$
Open loop Gain (Note 8)		Load = 1 nF in series with 1 k $\Omega$ in parallel with 10 pF to ground		73		dB
Source Current		Input Differential -200 mV		200		$\mu\text{A}$
Sink Current		Input Differential 200 mV		200		$\mu\text{A}$
-3dB Bandwidth (Note 8)		Load = 1 nF in series with 1 k $\Omega$ in parallel with 10 pF to ground		15		MHz
<b>CURRENT SENSE AMPLIFIER</b>						
Input Bias Current		$V_{CSP} = V_{CSN} = 1.2\text{ V}$	-50		50	nA
Common Mode Input Range (Note 8)		$V_{CSP} = V_{CSN}$	0		2.0	V
Common Mode Rejection		$V_{CSP} = V_{CSN} = 0.5\text{ V to }1.2\text{ V}$	45	80		dB
Differential Input Voltage Range (Note 8)		$V_{CSN} = 1.2\text{ V}$	-70		70	mV
-3dB Bandwidth (Note 8)				6		MHz
<b>IOUT</b>						
Gain	$gm_{IOUT}$	$0\text{ mV} \leq V_{CSP} - V_{CSN} \leq 25\text{ mV}; 25^{\circ}\text{C}$	0.95	1.0	1.05	mS
Output Offset Current		$0 \leq V_{IOUT} \leq 2\text{ V}$	-250		250	nA
Maximum Output Current (Note 8)		$0 \leq V_{IOUT} \leq 2\text{ V}$	70			$\mu\text{A}$
Maximum Output Voltage (Note 8)		$I_{IOUT} = -100\ \mu\text{A}$	2.1			V
<b>DROOP OUTPUT (VSP PIN)</b>						
Gain	$gm_{VSP}$	$0\text{ V} \leq V_{CSP} - V_{CSN} \leq 0.1\text{ V}$	0.94	1.0	1.06	mS
Output Offset Current		$0.5 \leq V_{VSP} \leq 1.2\text{ V}$	-1100		1100	nA
Maximum Output Current (Note 8)		$0 \leq V_{VSP} \leq 1.8\text{ V}$	70			$\mu\text{A}$
Output Voltage Range (Note 8)		$I_{VSP} = -100\ \mu\text{A}$	1.8			V
<b>OVERCURRENT PROTECTION (ILIM PIN)</b>						
Gain	$gm_{ILIM}$	$18\text{ mV} \leq V_{CSP} - V_{CSN} \leq 50\text{ mV}$	0.90	1.0	1.08	mS
Output Offset Current		$V_{ILIM} = 1.3\text{ V}$	-1.0		1.0	$\mu\text{A}$
Maximum Output Current (Note 8)		$0 \leq V_{ILIM} \leq 1.3\text{ V}$	70			$\mu\text{A}$
Maximum Output Voltage (Note 8)		$I_{ILIM} = -100\ \mu\text{A}$	1.4			V
Activation Threshold Voltage	$V_{CL}$		1.275	1.3	1.325	V
Activation Delay (Note 8)				250		ns
<b>OSCILLATOR</b>						
Switching Frequency Range			200		1200	kHz
<b>ZCD COMPARATOR</b>						
Offset Accuracy (Note 8)		Referred to $V_{CSP} - V_{CSN}$		$\pm 1.5$		mV

# NCP81248

**Table 6. ELECTRICAL CHARACTERISTICS – SINGLE PHASE REGULATORS** ( $V_{CC} = 5.0\text{ V}$ ,  $V_{EN} = 2.0\text{ V}$ ,  $C_{VCC} = 0.1\ \mu\text{F}$  unless specified otherwise) Min/Max values are valid for the temperature range  $-40^{\circ}\text{C} \leq T_A \leq 100^{\circ}\text{C}$  unless noted otherwise, and are guaranteed by test, design or statistical correlation.

Parameter	Symbol	Test Conditions	Min	Typ	Max	Unit
<b>OUTPUT OVER VOLTAGE &amp; UNDER VOLTAGE PROTECTION (OVP &amp; UVP)</b>						
Over Voltage Threshold	$V_{OVP1}$	$V_{VSP} - V_{VSN} - VID$ rising	365		430	mV
Absolute Over Voltage Threshold	$V_{OVABS1}$	CSN voltage during soft-start		2		V
Over Voltage Delay (Note 8)		$V_{VSP}$ rising to PWM low		25		ns
Over Voltage VR_RDY Delay (Note 8)		$V_{VSP}$ rising to VR_RDY low		350		ns
Under Voltage Threshold	$V_{UVM1}$	$V_{VSP} - V_{VSN} - VID$ falling	-400	-295	400	mV
Under-voltage Hysteresis (Note 8)				25		mV
Under-voltage Blanking Delay (Note 8)		$V_{VSP} - V_{VSN}$ falling to VR_RDY falling		5		$\mu\text{s}$
<b>TSENSE_1ph</b>						
Alert# Assert Threshold		25°C to 100°C		490		mV
Alert# De-assert Threshold		25°C to 100°C		502		mV
VRHOT Assert Threshold		25°C to 100°C		476		mV
VRHOT Rising Threshold		25°C to 100°C		480		mV
Bias Current		25°C to 100°C	116	120	124	$\mu\text{A}$
<b>ICCMAX PINS</b>						
Bias Current (Note 8)	$I_{MXBIAS1A}$	Applied only after enabling, and prior to soft-start.	9.53	9.98	10.33	$\mu\text{A}$
	$I_{MXBIAS1B}$		9.53	9.94	10.33	$\mu\text{A}$

Product parametric performance is indicated in the Electrical Characteristics for the listed test conditions, unless otherwise noted. Product performance may not be indicated by the Electrical Characteristics if operated under different conditions.

8. Guaranteed by design or characterization data. Not tested in production.

# NCP81248

## General Information

The NCP81248 is a three-rail IMVP8 controller with an Intel proprietary control interface.

The table below specifies the ADDR\_VBOOT pin pulldown resistor (1% tolerance required) needed to program all possible supply rail configurations. Four boot voltages are available for all rails except for the SA rail.

## Serial VID interface (Intel proprietary interface)

For Intel proprietary interface communication details please contact Intel<sup>®</sup>, Inc.

**RAIL CONFIGURATION TABLE**

AD-DR_VBOOT Resistance	SYSTEM RAIL									Configuration
	Rail1			Rail2			Rail3			
	PHASE COUNT	TSENSE _1PH	Boot Voltage	PHASE COUNT	TSENSE _2PH	Boot Voltage	PHASE COUNT	a/b	Boot Voltage	
a/b										
10k	1	a	0 V	2 or 1		0 V	1	b	1.05 V	1+2+1 Rail1+Rail2+Rail3
16.2k	1	a	1.2 V	2 or 1		1.2 V	1	b		
22.1k	1	a	1.05 V	2 or 1		1.05 V	1	b		
28.7k	1	a	1.0 V	2 or 1		1.0 V	1	b		
AD-DR_VBOOT Resistance	Rail1			Rail2			Rail3			Configuration
	PHASE COUNT	TSENSE _2PH	Boot Voltage	PHASE COUNT	TSENSE _1PH	Boot Voltage	PHASE COUNT	a/b	Boot Voltage	
		a/b								
35.7k	2 or 1		0 V	1	a	0 V	1	b	1.05 V	2+1+1 Rail1+Rail2+Rail3
43.2k	2 or 1		1.2 V	1	a	1.2 V	1	b		
51.1k	2 or 1		1.05 V	1	a	1.05 V	1	b		
61.9k	2 or 1		1.0 V	1	a	1.0 V	1	b		
AD-DR_VBOOT Resistance	Rail1			Rail2			Rail3			Configuration
	PHASE COUNT	TSENSE _1PH	Boot Voltage	PHASE COUNT	TSENSE _2PH	Boot Voltage	PHASE COUNT	a/b	Boot Voltage	
		a/b								
71.5k	1	b	0 V	2 or 1		0 V	1	a	1.05 V	1+2+1 Rail3+Rail2+Rail1
82.5k	1	b	1.2 V	2 or 1		1.2 V	1	a		
95.3k	1	b	1.05 V	2 or 1		1.05 V	1	a		
110k	1	b	1.0 V	2 or 1		1.0 V	1	a		
AD-DR_VBOOT Resistance	Rail1			Rail2			Rail4			Configuration
	PHASE COUNT	TSENSE PSYS	Boot Voltage	PHASE COUNT	TSENSE _2PH	Boot Voltage	PHASE COUNT	TSENSE _1PH	Boot Voltage	
		a/b						a/b		
127k	1	b	0 V	2 or 1		0 V	1	a	0 V	1+2+1 Rail1+Rail2+Rail4
143k	1	b	1.2 V	2 or 1		1.2 V	1	a	1.2 V	
165k	1	b	1.05 V	2 or 1		1.05 V	1	a	1.05 V	
187k	1	b	1.0 V	2 or 1		1.0 V	1	a	1.0 V	

**Start Up**

Following the rise of  $V_{CC}$  above the UVLO threshold, externally programmed configuration data is collected, and the PWM outputs are set to Mid-level to prepare the gate drivers of the power stages for activation. When the controller is enabled, DRVON is asserted (high) to activate

the gate drivers. A digital counter steps the DAC up from zero to the target voltage based on the Soft Start Slew Rate in the spec table. As the DAC ramps, the PWM outputs of each rail will change from Mid-level to high when the first PWM pulse for that rail is produced. When the controller is disabled, the PWM signals return to Mid-level.

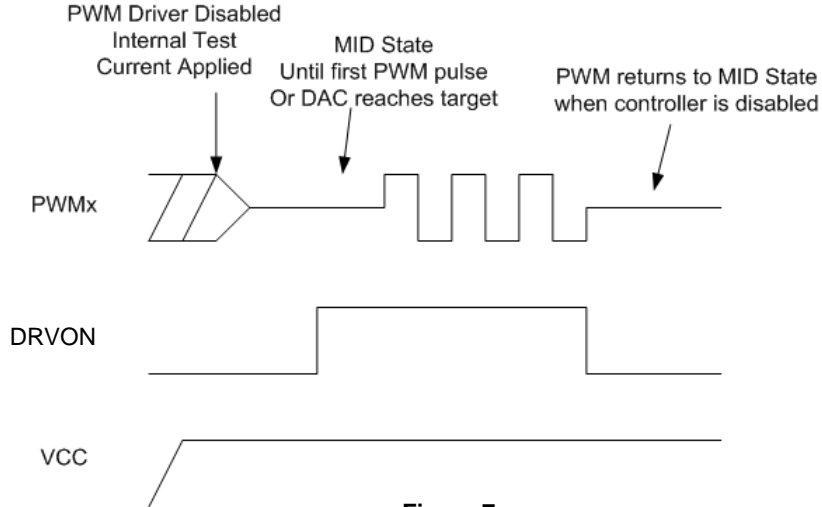

Figure 7.

**Phase Count, Rail Disabling & PSYS Disabling Detection Sequence**

During start-up, the number of operational phases of the 2-phase rail, and whether or not each single-phase rail becomes active and responds to an address call on the Intel proprietary interface bus, is determined by the internal circuitry monitoring the CSP inputs. Normally, the 2-phase rail operates with both phases. If CSP2\_2ph is externally pulled to  $V_{CC}$  with a resistor during startup, the two-phase rail operates as a single-phase rail, and does not use PWM2\_2ph and CSP2\_2ph. Likewise, if CSP of either or both single-phase rails is pulled to  $V_{CC}$  during startup, it is disabled and will not respond to any address calls on the Intel proprietary interface bus.

Also, whether or not the PSYS function is active and responds to an address call on the Intel proprietary interface bus is determined by the internal circuitry monitoring the PSYS input. Tying the PSYS input to  $V_{CC}$  will cause the NCP81248 to not respond to any calls to address 0Dh on the Intel proprietary interface bus.

**Switching Frequency**

Switching frequencies between 200 kHz and 1.2 MHz are programmed at startup with pulldown resistors on pins 14 and 15. The 1a and 2-phase regulators are programmed to the same switching frequency by the pin 14 resistor, and the Rail3 or Rail1 (usually the 1b regulator) is programmed by the pin 15 resistor.

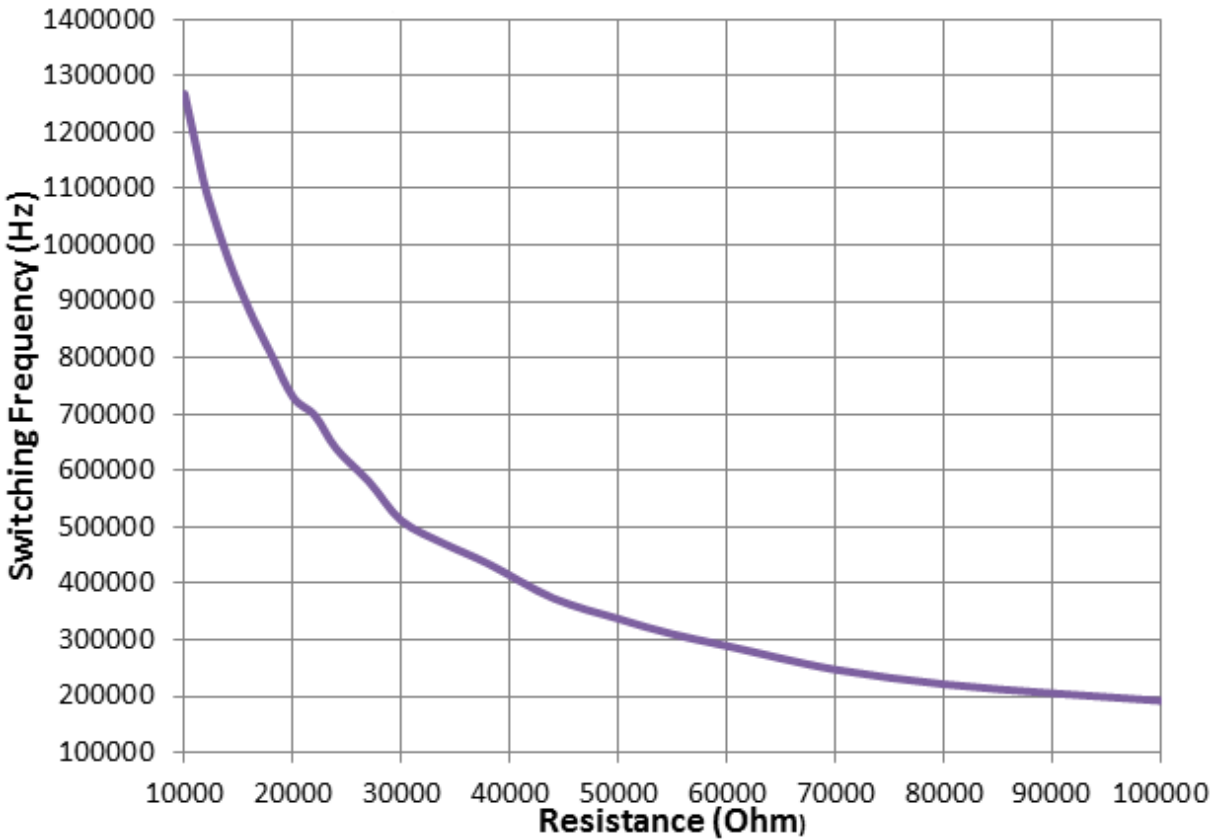

Figure 8. Switching Frequency vs. ROSC Resistance

The Rail1/Rail2 oscillator serves as the master clock for the 2-phase rail ramp generator when configured for 2-phase operation, and as a frequency stabilization clock for a single phase rail and for the 2-phase rail when it is configured for single phase operation. The SA/US oscillator serves as a frequency stabilization clock for the Rail3.

The formulas to calculate the switching frequency and programming resistances are:

$$R_{OSC} = 2 * 10^{+11} * \text{Frequency}^{-1.192} [\Omega] \quad (\text{eq. 1})$$

$$\text{Frequency} = 3 * 10^{+9} * R_{OSC}^{-0.838} [\text{Hz}] \quad (\text{eq. 2})$$

**Input Voltage Feed-Forward (VRAMP pin)**

Ramp generator circuits are provided for both the dual-edge modulator (only when 2-phases are operating) and three RPM modulators. The ramp generators implement input voltage feed-forward control by varying the ramp slopes proportional to the VRMP pin voltage. The VRMP pin also has a 4 V UVLO function, which is active only after the controller is enabled. The VRMP pin is high impedance input when the controller is disabled.

For 2-phase operation, the dual-edge PWM ramp amplitude is changed according to the following,

$$V_{RAMP\_pp} = 0.1 * V_{VRMP} \quad (\text{eq. 3})$$

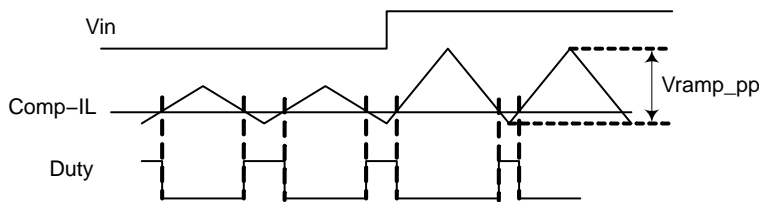

Figure 9.



**Programming Two-Phase Rail ICC\_MAX**

A resistor to ground on the ICCMAX\_2ph pin programs the register for the 2-phase rail at the time the part is enabled. Current  $I_{MXBIAS2}$  is sourced from this pin to generate a voltage on the program resistor. The resistor value should be no less than 10k.

$$ICC\_MAX_{21h} = \frac{R * I_{MXBIAS2} * 128 A}{2 V} \quad (eq. 4)$$

**Programming TSENSE**

Two temperature sense inputs are provided – one for the 2-phase rail, and the other for single-phase rail 1a. A precision current is sourced out the output of the TSENSE pins to generate a voltage on the temperature sense networks. The voltages on the temperature sense inputs are sampled by the internal A/D converter. A 100k NTC similar to the Murata NCP15WF104E03RC should be used. Rcomp1 in the following Figure is optional, and can be used to slightly change the hysteresis. See the specification table for the thermal sensing voltage thresholds and source current.

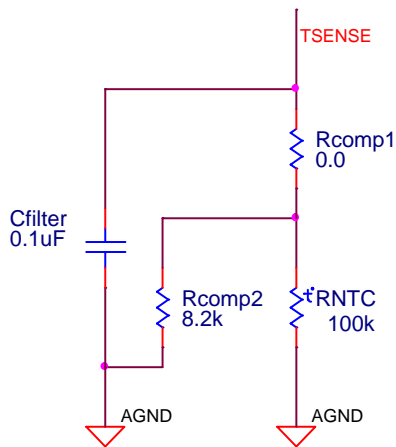

Figure 10.

**Ultrasonic Mode**

The switching frequency of a rail in DCM will decrease at very light loads. Ultrasonic Mode forces the switching frequency to stay above the audible range.

**Two-Phase Rail Remote Sense Amplifier**

A high performance high input impedance true differential amplifier is provided to accurately sense regulator output voltage. The VSP and VSN inputs should be connected to the regulator’s output voltage sense points. The remote sense amplifier takes the difference of the output voltage with the DAC voltage and adds the droop voltage.

$$V_{DIFFOUT} = (V_{VSP} - V_{VSN}) + (1.3 V - V_{DAC}) + (V_{DROOP} - V_{CSREF}) \quad (eq. 5)$$

This signal then goes through a standard error compensation network and into the inverting input of the error amplifier.

**Two-phase Rail Voltage Compensation**

The Remote Sense Amplifier output feeds a Type III compensation network formed by the Error Amplifier and external tuning components. The non-inverting input of the error amplifier is connected to the same reference voltage used to bias the Remote Sense Amplifier output.

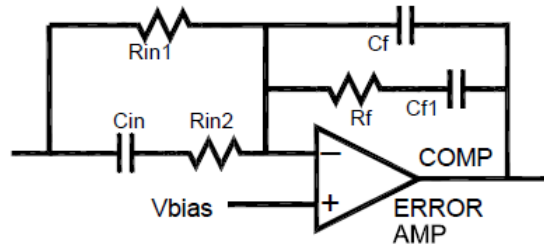
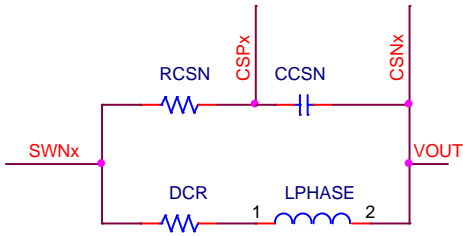

Figure 11.

**Two-Phase Rail Differential Current Feedback Amplifiers**

Each phase of the two-phase rail has a low offset, differential amplifier to sense the current of that phase in order to balance current. The CSREF and CSPx pins are high impedance inputs, but it is recommended that any external filter resistor RCSN does not exceed 10 kΩ to avoid offset due to leakage current. It is also recommended that the voltage sense element be no less than 0.5 mΩ for best current balance. The external filter RCSN and CCSN time constant should match the inductor L/DCR time constant, but fine tuning of this time constant is generally not required. Phase current signals are summed with the COMP or ramp signals at their respective PWM comparator inputs in order to balance phase currents via a current mode control approach.



$$R_{CSN} = \frac{L_{PHASE}}{C_{CSN} * DCR} [\Omega]$$

Figure 12.

**Two-Phase Rail Total Current Sense Amplifier**

The NCP81248 uses a patented approach to sum the phase currents into a single, temperature compensated, total current signal. This signal is then used to generate the output voltage droop, total current limit, and the output current monitoring functions. The Rref(n) resistors average the voltages at the output terminals of the inductors to create a low impedance reference voltage at CSREF. The Rph resistors sum currents from the switchnodes to the virtual CSREF potential created at the CSSUM pin by the amplifier. The total current signal is the difference between the CSCOMP and CSREF voltages. The amplifier filters, and amplifies, the voltage across the inductors in order to extract only the voltage across the inductor series resistances (DCR). An NTC thermistor (Rth) in the feedback network placed near the Phase 1 inductor senses the inductor temperature, and compensates both the DC gain and the filter time constant for the change in DCR with temperature. The Phase 1 inductor is chosen for the thermistor location so that the temperature of the inductor providing current in the PS1 power mode.

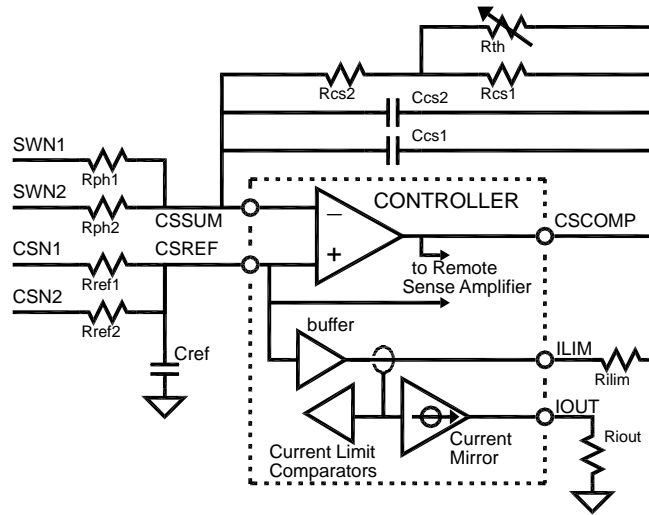

Figure 13.

The DC gain equation for the DC total current signal is:

$$V_{CSCOMP-CSREF} = \frac{R_{CS2} + \frac{R_{CS1} * R_{th}}{R_{CS1} + R_{th}}}{R_{ph}} * (I_{outTotal} * DCR) \quad (eq. 6)$$

Set the DC gain by adjusting the value of the Rph resistors in order to make the ratio of total current signal to output current equal the desired loadline.

The values of Rcs1 and Rcs2 are set based on the effect of temperature on both the thermistor and inductor, and may need to be adjusted to eliminate output voltage temperature drift with the final product enclosure and cooling.

The pole frequency of the CSCOMP filter should be set equal to the zero of the output inductor. This causes the total current signal to contain only the component of inductor voltage caused by the DCR voltage, and therefore to be

proportional to inductor current. Connecting Ccs2 in parallel with Ccs1 allows fine tuning of the pole frequency using commonly available capacitor values. It is best to perform fine tuning during transient testing.

$$F_z = \frac{DCR @ 25C}{2 * \pi * L_{Phase}} [Hz] \quad (eq. 7)$$

$$F_p = \frac{1}{2 * \pi * \left( R_{CS2} + \frac{R_{CS1} * R_{th} @ 25C}{R_{CS1} + R_{th} @ 25C} \right) (C_{CS1} + C_{CS2})} [Hz] \quad (eq. 8)$$

The value of the CREF capacitor (in nF) on the CSREF pin should be:

$$C_{REF} = \frac{0.02 * R_{PH}}{R_{REF}} [nF] \quad (eq. 9)$$

**Two-Phase Rail Loadline Programming (DROOP)**

An output loadline is a power supply characteristic wherein the regulated (DC) output voltage decreases proportional to load current. This characteristic can reduce the output capacitance required to maintain output voltage within limits during load transients faster than those to which the regulation loop can respond. In the NCP81248, a loadline is produced by adding a signal proportional to output load current ( $V_{DROOP}$ ) to the output voltage feedback signal – thereby satisfying the voltage regulator at an output voltage reduced proportional to load current.

The loadline is programmed by setting the gain of the Total Current Sense Amplifier such that the total current signal is equal to the desired output voltage droop.

**Two-Phase Rail Programming the Current Limit**

The current limit thresholds are programmed with a resistor between the ILIM and CSCOMP pins. The NCP81248 generates a replica of the CSREF pin voltage at the ILIM pin, and compares ILIM pin current to  $I_{CL0}$  and  $I_{CLM0}$ . The NCP81248 latches off if ILIM pin current exceeds  $I_{CL0}$  ( $I_{CL1}$  for PS1, PS2, and PS3) for  $t_{OCPDLY}$ , and latches off immediately if ILIM pin current exceeds  $I_{CLM0}$  ( $I_{CLM1}$  for PS1, PS2 and PS3). Set the value of the current limit resistor  $R_{LIMIT}$  according to the desired current limit  $I_{out\_LIMIT}$ :

$$R_{LIMIT} = \frac{\frac{R_{cs2} + \frac{R_{cs1} \cdot R_{th}}{R_{cs1} + R_{th}}}{R_{ph}} \cdot (I_{out\_LIMIT} \cdot DCR)}{10\mu} \quad \text{(eq. 10)}$$

**Two-Phase Rail Programming IOUT**

The IOUT pin sources a current proportional to the ILIM current. The voltage on the IOUT pin is monitored by the internal A/D converter and should be scaled with an external resistor to ground such that a load equal to  $I_{CCMAX}$  generates a 2 V signal on IOUT. A pull-up resistor from 5 V  $V_{CC}$  can be used to offset the IOUT signal positive if desired.

$$R_{IOUT} = \frac{2.0 \text{ V} \cdot R_{LIMIT}}{10 \cdot \frac{R_{cs2} + \frac{R_{cs1} \cdot R_{th}}{R_{cs1} + R_{th}}}{R_{ph}} \cdot (I_{out\_ICCMAX} \cdot DCR)} \quad \text{(eq. 11)} \quad [\Omega]$$

**Two-Phase Rail Programming DAC Feed-Forward Filter**

The NCP81248 outputs a pulse of current from the VSN pin upon each increment of the internal DAC following a DVID UP command. A parallel RC network inserted into the path from VSN to the output voltage return sense point,  $VSS\_SENSE$ , causes these current pulses to temporarily decrease the voltage between VSP and VSN. This causes the output voltage during DVID to be regulated slightly higher, in order to compensate for the response of the Droop function to current flowing into the charging output capacitors. In the following equations,  $C_{out}$  is the total output capacitance of the system.

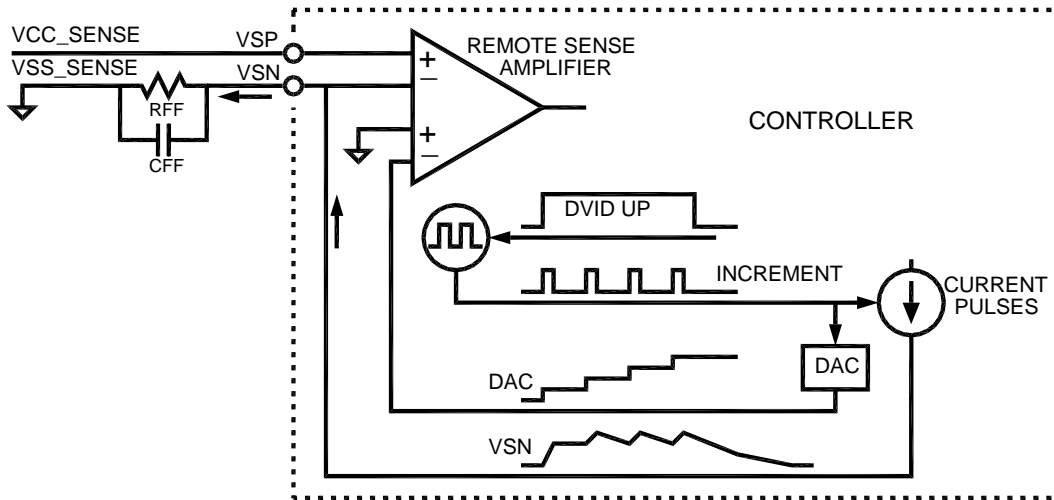

Figure 14.

$$R_{FF} = \frac{\text{Loadline} \cdot C_{out}}{9.35 \cdot 10^{-10}} [\Omega] \quad \text{(eq. 12)}$$

$$C_{FF} = \frac{200}{R_{FF}} [nF] \quad \text{(eq. 13)}$$

**Two-Phase Rail PWM Comparators**

The noninverting input of each comparator (one for each phase) is connected to the summation of the error amplifier output (COMP) and each phase current ( $I_L \cdot DCR \cdot \text{Phase Balance Gain Factor}$ ). The inverting input is connected to the triangle ramp voltage of that phase. The output of the comparator generates the PWM output.

The main rail PWM pulses are centered on the valley of the triangle ramp waveforms and both edges of the PWM signals are modulated. During a transient event, the duty cycle can increase rapidly as the error amp signal increases with respect to the ramps, to provide a highly linear and proportional response to the step load.

**Single-Phase Rails**

The architecture of the two single-phase rails makes use of a digitally enhanced, high performance, current mode RPM control method that provides excellent transient response while minimizing transient aliasing. The average operating frequency is digitally stabilized to remove frequency drift under all continuous mode operating conditions.

**Features of the single-phase rails**

- Supports Intel proprietary interface Addresses 00, 01, 02, 03
- Adjustable Vboot
- Programmable Slew Rate
- Dynamic VID Feed-Forward
- High performance RPM control system
- Programmable Droop Gain (Zero Droop Capable)
- Low Offset IOUT monitor
- Thermal Monitor
- Digitally Controlled Operating Frequency
- UltraSonic Operation

**Single-phase Rail Frequency Programming**

One of the two single-phase rails has frequency programmed by the ROSC\_COREGT pin, and the other has frequency programmed by the ROSC\_SAU5 pin. ROSC\_COREGT always controls the frequency of the Rail1 and Rail2 unless there are two Rail2. In that case, ROSC\_COREGT controls the frequency of both Rail2, and ROSC\_SAU5 controls the frequency of the Rail1.

**Single-phase Rail Remote Sense Error Amplifier**

A high performance, high input impedance, differential transconductance amplifier is provided to accurately sense the regulator output voltage and provide high bandwidth transient performance. The VSP and VSN inputs should be

connected to the regulator’s output voltage sense points through filter networks described in the Droop Compensation and DAC Feedforward Compensation sections. The remote sense error amplifier outputs a current proportional to the difference between the VSP, VSN and DAC voltages:

$$I_{COMP} = gm_{EA} \times [V_{DAC} - (V_{VSP} - V_{VSN})] \text{ (eq. 14)}$$

**Single-phase rail voltage compensation**

The Remote Sense Amplifier output current is applied to a standard Type II compensation network formed by external tuning components CLF, RZ and CHF.

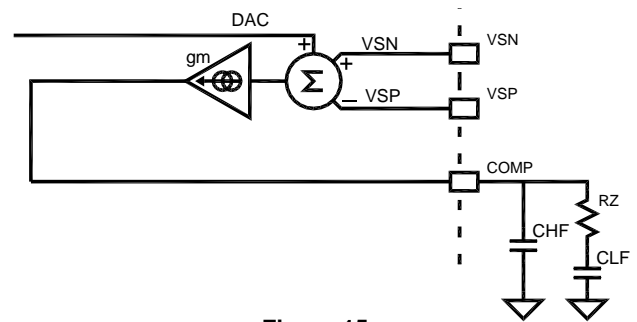

Figure 15.

**Single-phase Rail – Programming the DAC Feed-Forward Filter**

The DAC feed-forward implementation for the single-phase rail is the same as for the 2-phase rail. The NCP81248 outputs a pulse of current from the VSN pin upon each increment of the internal DAC following a DVID UP command. A parallel RC network inserted into the path from VSN to the output voltage return sense point, VSS\_SENSE, causes these current pulses to temporarily decrease the voltage between VSP and VSN. This causes the output voltage during DVID to be regulated slightly higher, in order to compensate for the Droop function response to inductor current flowing into the charging output capacitors. RFFSP sets the gain of the DAC feed-forward and CFFSP provides the time constant to cancel the time constant of the system per the following equations. Cout is the total output capacitance of the system.

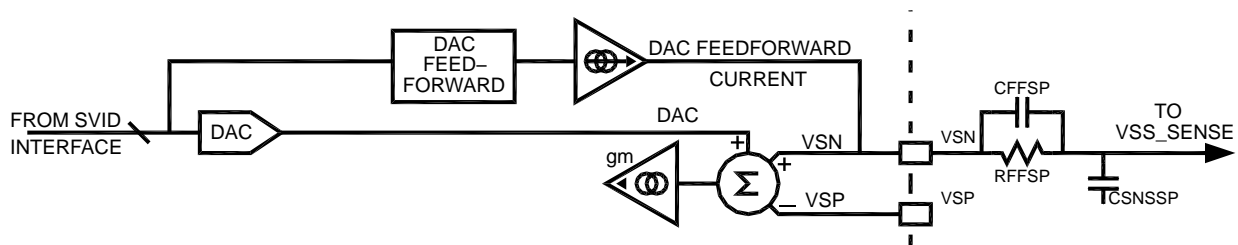

Figure 16.

$$R_{FFSP} = \frac{Loadline * Cout}{1.35 * 10^{-9}} [\Omega] \text{ (eq. 15)}$$

$$C_{FFSP} = \frac{200}{R_{FFSP}} [nF] \text{ (eq. 16)}$$

**Single-phase Rail – Differential Current Feedback Amplifier**

Each single-phase controller has a low offset, differential amplifier to sense output inductor current. An external lowpass filter can be used to superimpose a reconstruction of the AC inductor current onto the DC current signal sensed across the inductor. To do this, the lowpass filter time constant should match the inductor L/DCR time constant by setting the filter pole frequency equal to the zero of the output inductor. This makes the filter AC output mimic the product of AC inductor current and DCR, with the same gain as the filter DC output. It is best to perform fine tuning of the filter pole during transient testing.

$$F_Z = \frac{DCR@25C}{2 * \pi * L} \text{ [Hz]} \quad (\text{eq. 17})$$

$$F_P = \frac{1}{2 * \pi * \frac{R_{PHSP} * (R_{th} + R_{CSSP})}{R_{PHSP} + R_{th} + R_{CSSP}} * C_{CSSP}} \text{ [Hz]} \quad (\text{eq. 18})$$

Forming the lowpass filter with an NTC thermistor (Rth) placed near the output inductor, compensates both the DC gain and the filter time constant for the inductor DCR change with temperature. The values of RPHSP and RCSSP are set based on the effect of temperature on both the thermistor and

inductor, and may need to be adjusted to eliminate output voltage temperature drift with the final product enclosure and cooling.. The CSP and CSN pins are high impedance inputs, but it is recommended that the lowpass filter resistance not exceed 10 kΩ in order to avoid offset due to leakage current. It is also recommended that the voltage sense element (inductor DCR) be no less than 0.5 mΩ for sufficient current accuracy. Recommended values for the external filter components are:

$$C_{CSSP} = \frac{L_{PHASE}}{\frac{R_{PHSP} * (R_{th} + R_{CSSP})}{R_{PHSP} + R_{th} + R_{CSSP}} * DCR} \text{ [F]} \quad (\text{eq. 19})$$

- RPHSP = 7.68 kΩ
- RCSSP = 14.3 kΩ
- Rth = 100 kΩ, Beta = 4300

Using two parallel capacitors in the lowpass filter allows fine tuning of the pole frequency using commonly available capacitor values.

The DC gain equation for the current sense amplifier output is:

$$V_{CURR} = \frac{R_{th} + R_{CSSP}}{R_{PHSP} + R_{th} + R_{CSSP}} * I_{out} * DCR \quad (\text{eq. 20})$$

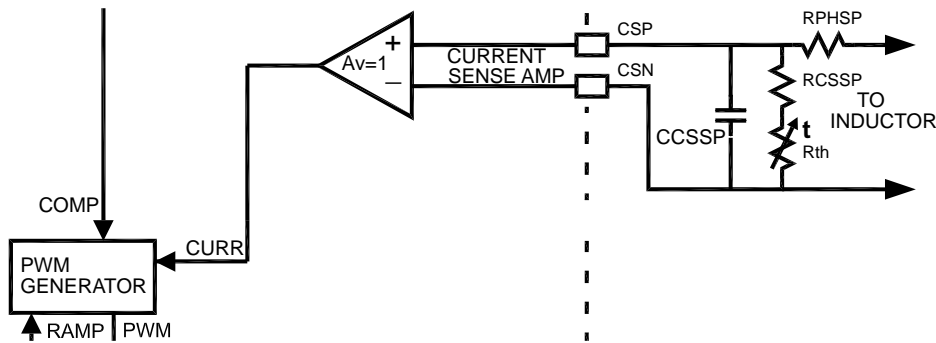

Figure 17.

The amplifier output signal is combined with the COMP and RAMP signals at the PWM comparator inputs to produce the Ramp Pulse Modulation (RPM) PWM signal.

**Single-phase Rail – Loadline Programming (DROOP)**

An output loadline is a power supply characteristic wherein the regulated (DC) output voltage decreases by a voltage (VDROOP) proportional to load current. This characteristic can reduce the output capacitance required to

maintain output voltage within limits during load transients faster than those to which the regulation loop can respond. In the NCP81248, a loadline is produced by adding VDROOP to the output voltage feedback signal – thereby satisfying the voltage regulator at an output voltage reduced in proportion to load current. VDROOP is developed across a resistance between the VSP pin and the output voltage sense point by forcing current from the VSP pin that is proportional to the difference between the CSP and CSN voltages.

# NCP81248

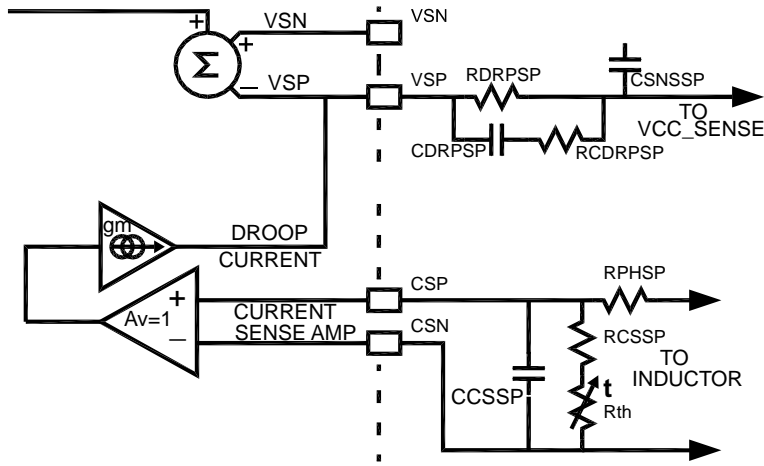

Figure 18.

$$V_{\text{DROOP}} = R_{\text{DRPSP}} \times g_{m_{\text{VSP}}} \times \frac{R_{\text{th}} + R_{\text{CS}}}{R_{\text{PHSP}} + R_{\text{th}} + R_{\text{CS}}} \times I_{\text{OUT}} \times \text{DCR} \quad (\text{eq. 21})$$

$$R_{\text{DRPSP}} = \frac{\text{Loadline}}{g_{m_{\text{VSP}}} \times \text{DCR}} \times \frac{R_{\text{PHSP}} + R_{\text{th}} + R_{\text{CS}}}{R_{\text{th}} + R_{\text{CS}}} \quad [\Omega] \quad (\text{eq. 22})$$

## Single-phase Rail – Programming IOUT

The IOUT pin sources a current proportional to the voltage between the CSP and CSN pins. The voltage on the IOUT pin is monitored by the internal A/D converter and should be scaled with an external resistor to ground such that a load equal to ICCMAX generates a 2 V signal on IOUT. A high-value pull-up resistor from 5 V VCC can be used to offset the IOUT signal positive if desired.

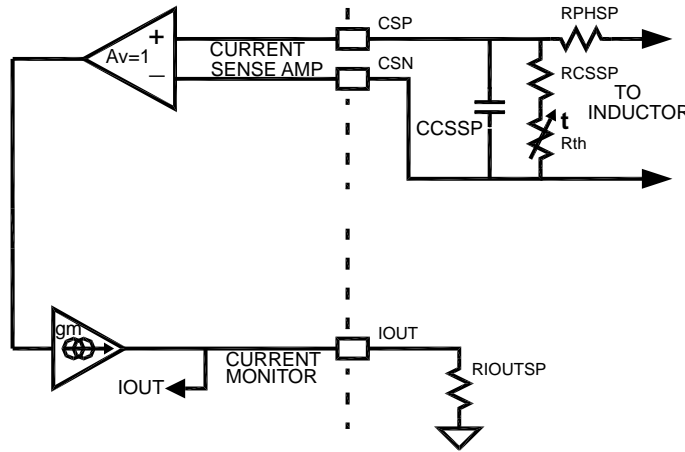

Figure 19.

$$R_{\text{IOUTSP}} = \frac{2 \text{ V}}{g_{m_{\text{IOUT}}} \times \frac{R_{\text{th}} + R_{\text{CS}}}{R_{\text{PHSP}} + R_{\text{th}} + R_{\text{CS}}} \times \text{ICCMAX} \times \text{DCR}} \quad (\text{eq. 23})$$

**Programming the Single-Phase Rail ICC\_MAX**

Resistors to ground on the ICCMAX\_1a and ICCMAX\_1b pins program these registers for the single phase rails at the time the part is enabled.  $I_{MXBIAS1A}$  and  $I_{MXBIAS1B}$  currents are sourced from these pins to generate a voltage on the program resistors. The resistor value should be no less than 10k.

$$ICC\_MAX_{21h} = \frac{R * I_{MXBIAS1} * 64 A}{2 V} \quad (eq. 24)$$

**Single-phase Rail Pulsewidth Modulator**

A PWM pulse starts when the Error Amp output (COMP voltage) exceeds a trigger threshold including a scaled

inductor current ( $I_L * DCR * \text{Phase Current Gain Factor}$ ). The PWM pulse ends when scaled inductor current added to a compensating reset ramp exceeds the COMP voltage. Both edges of the PWM signals are modulated. During a transient event, the duty cycle can increase rapidly as the COMP voltage increases with respect to the trigger threshold and reset ramp, to provide a highly linear and proportional response to the step load.

**Disabling a Single-Phase Rail**

If the NCP81248 is to provide fewer than three rails, either or both of the single-phase regulators can be disabled by pulling up their respective CSP pin to VCC. The two-phase regulator cannot be disabled.

**PROTECTION FEATURES**

**Two-Phase Regulator Over Current Protection (OCP)**

A programmable total phase current limit is provided that is decreased when not operating in full current mode. This limit is programmed with a resistor between the CSSCOMP and ILIM pins. The current from the ILIM pin to this resistor is compared to the ILIM Threshold Currents ( $I_{CL0}$ ,  $I_{CLM0}$ ,  $I_{CL1}$ , and  $I_{CLM1}$ ). When the 2-phase rail is operating in full

current mode, if the ILIM pin current exceeds  $I_{CL0}$ , an internal latch-off timer starts. If the fault is not removed, the controller shuts down when the timer expires. If the current into the pin exceeds  $I_{CLM0}$ , the controller shuts down immediately. When operating in PS1, PS2, or PS3, the ILIM pin current limits are  $I_{CL1}$  and  $I_{CLM1}$ . To recover from an OCP fault, the EN pin or VCC voltage must be cycled low.

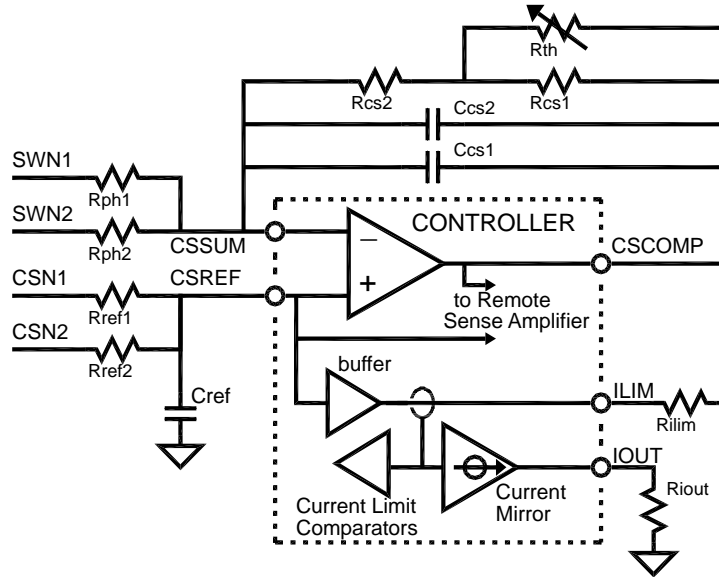

Figure 20.

Use Equation 10 to calculate the ILIM resistor value.

**Single-phase Rail Over Current Protection (OCP)**

The current limit threshold is programmed with a resistor ( $R_{ILIMSP}$ ) from the ILIM pin to ground. The current limit

latches the single-phase rail off immediately if the ILIM pin voltage exceeds the ILIM Threshold Voltage ( $V_{CL}$ ). Set the value of the current limit resistor based on the equation shown below.

# NCP81248

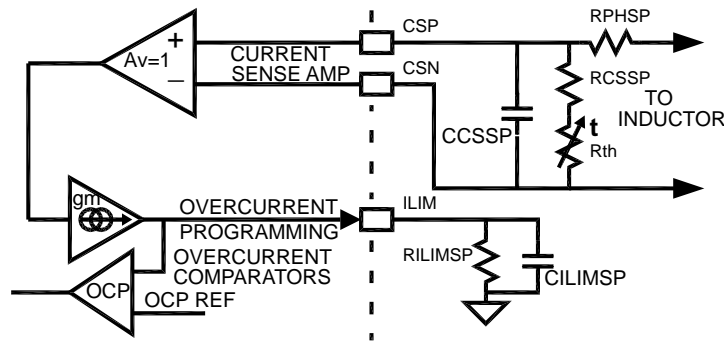

Figure 21.

$$R_{ILIMSP} = \frac{V_{CL}}{gm_{ILIM} \times \frac{R_{th} + R_{CSPP}}{R_{PHSP} + R_{th} + R_{CSPP}} \times I_{out\_LIMIT} \times DCR} \quad [\Omega] \quad (\text{eq. 25})$$

$$C_{ILIMSP} = \frac{5 \times 10^{-7}}{R_{ILIMSP}} \quad [\text{pF}] \quad (\text{eq. 26})$$

A capacitor ( $C_{ILIMSP}$ ) in parallel with the ILIM pin resistor creates a time delay to give some tolerance for output currents that momentarily exceed the current limit. The  $C_{ILIMSP}$  value given in the equation below will give up to a 50  $\mu\text{s}$  delay with a 150% overload depending on the load current prior to overload.

To recover from an OCP fault, the EN pin or  $V_{CC}$  voltage must be cycled low.

## Input Under-voltage Lockouts (UVLO)

NCP81248 monitors the 5 V  $V_{CC}$  supply as well as the VRMP pin voltage. Hysteresis is incorporated within these monitors.

## Output Under Voltage Monitor

The 2-phase rail output voltage is monitored for undervoltage at the output of the differential amplifier. If the 2-phase rail output falls more than  $V_{UVM2}$  below the DAC-DROOP voltage, the UVM comparator will trip – sending the VR\_RDY signal low. The single-phase rail outputs are monitored for undervoltage at the CSN inputs.

If the CSN voltage falls more than  $V_{UVM1}$  below the DAC voltage, the UVM comparator will trip – sending the VR\_RDY signal low.

## Output Over Voltage Protection

The 2-phase output voltage is monitored for OVP at the output of the differential amplifier and also at the CSREF pin. The single-phase regulator outputs are monitored for overvoltage at the VSP & VSN inputs, and also at the CSN inputs. During normal operation, if an output voltage exceeds the DAC voltage by  $V_{OVP}$ , the VR\_RDY flag goes low, and the DAC voltage of the overvoltage rail will be slowly ramped down to 0 V to avoid producing a negative output voltage. At the same time, the PWM outputs of the overvoltage rail are sent low. The PWM output will pulse to mid-level during the DAC ramp down period if the output decreases below the DAC + OVP Threshold as DAC decreases. When the DAC gets to zero, the PWMs will be held low, and the NCP81248 will stay in this mode until the  $V_{CC}$  voltage or EN is toggled.

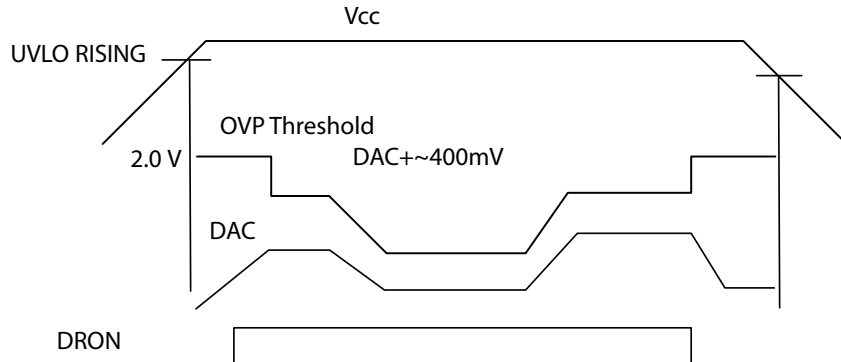

Figure 22. OVP Threshold Behavior



# NCP81248

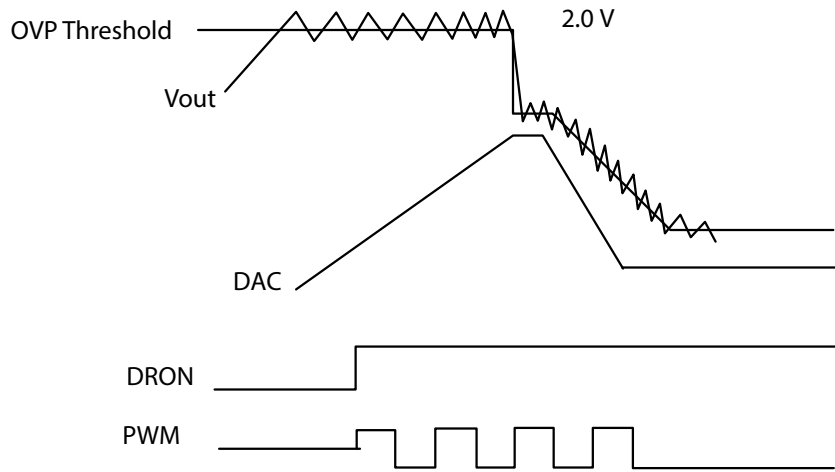

Figure 23. OVP Behavior at Startup

During start up, the OVP threshold is set to the Absolute Over Voltage Threshold. This allows the controller to start up without false triggering OVP.

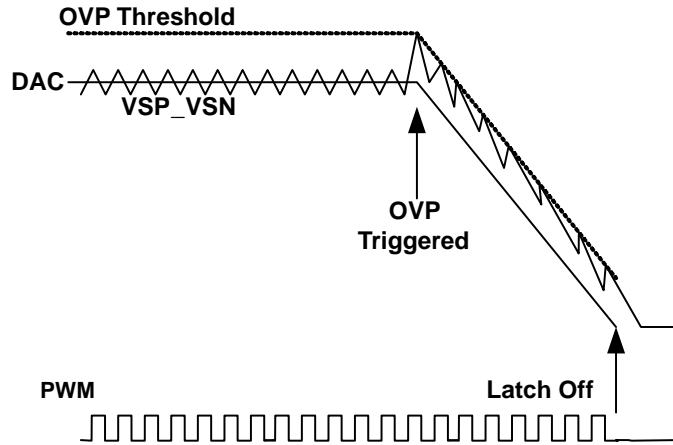

Figure 24. OVP During Normal Operation Mode

# NCP81248

## TYPICAL PCB LAYOUT

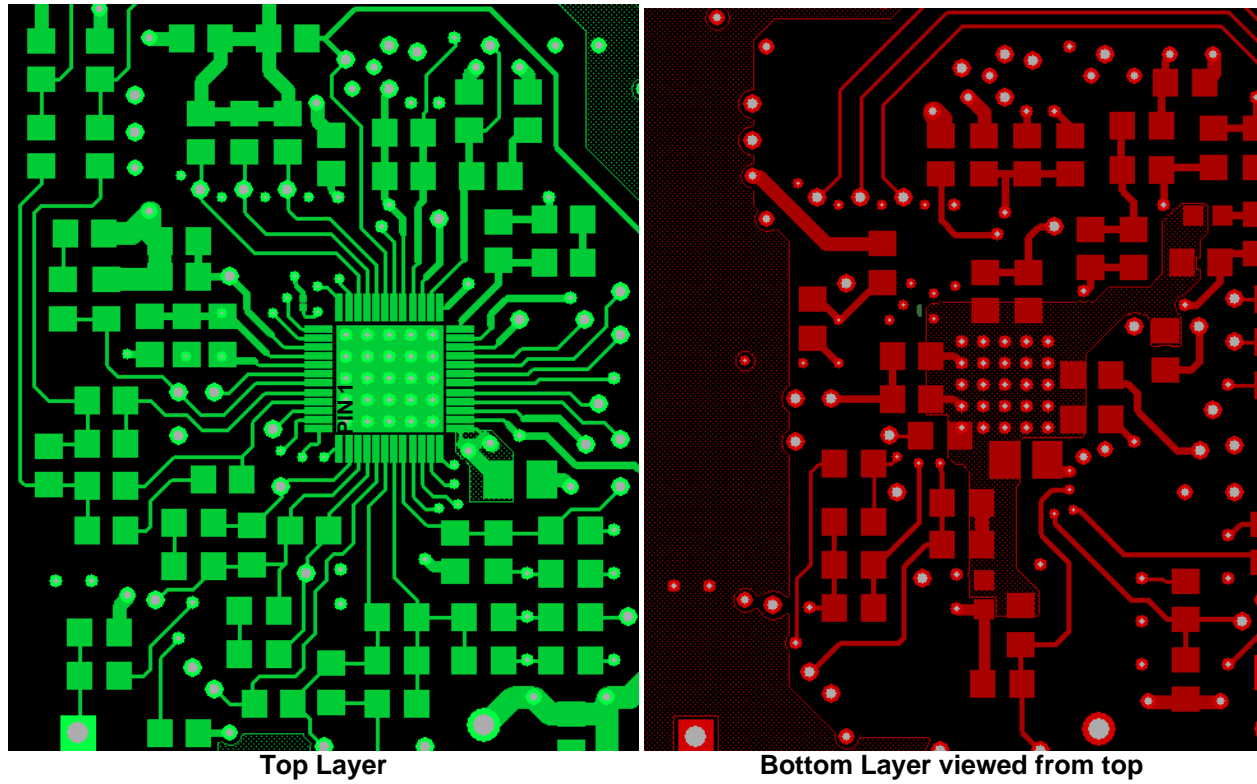
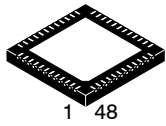

Figure 25.

# MECHANICAL CASE OUTLINE

## PACKAGE DIMENSIONS

ON Semiconductor®



1 48  
SCALE 2:1

**QFN48 6x6, 0.4P**  
CASE 485BA  
ISSUE A

DATE 16 FEB 2010

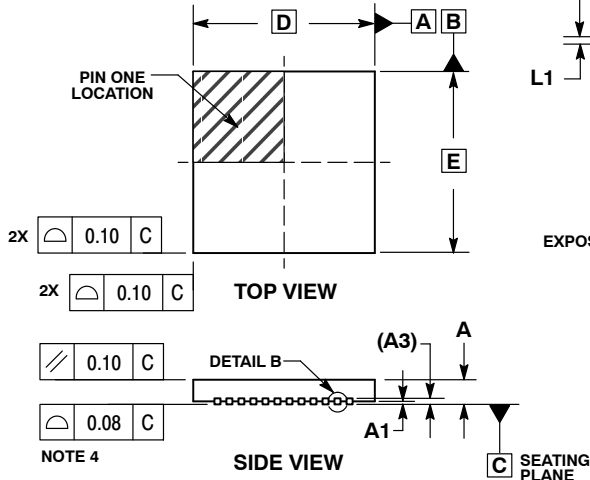

**NOTES:**

1. DIMENSIONING AND TOLERANCING PER ASME Y14.5M, 1994.
2. CONTROLLING DIMENSIONS: MILLIMETERS.
3. DIMENSION b APPLIES TO PLATED TERMINAL AND IS MEASURED BETWEEN 0.15 AND 0.30mm FROM TERMINAL TIP.
4. COPLANARITY APPLIES TO THE EXPOSED PAD AS WELL AS THE TERMINALS.

DIM	MILLIMETERS	
	MIN	MAX
A	0.80	1.00
A1	0.00	0.05
A3	0.20	REF
b	0.15	0.25
D	6.00	BSC
D2	4.40	4.60
E	6.00	BSC
E2	4.40	4.60
e	0.40	BSC
K	0.20	MIN
L	0.30	0.50
L1	0.00	0.15

**GENERIC MARKING DIAGRAM\***

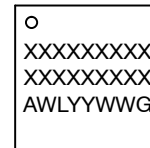

- XXX = Specific Device Code
- A = Assembly Location
- WL = Wafer Lot
- YY = Year
- WW = Work Week
- G = Pb-Free Package

\*This information is generic. Please refer to device data sheet for actual part marking. Pb-Free indicator, "G" or microdot "•", may or may not be present. Some products may not follow the Generic Marking.

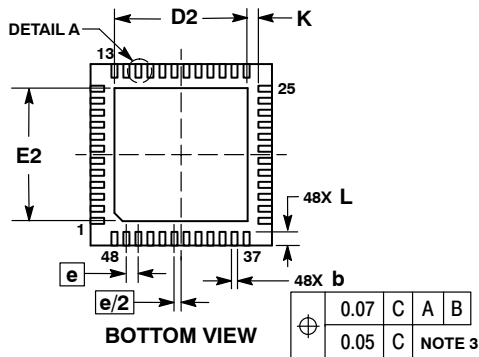

**SOLDERING FOOTPRINT\***

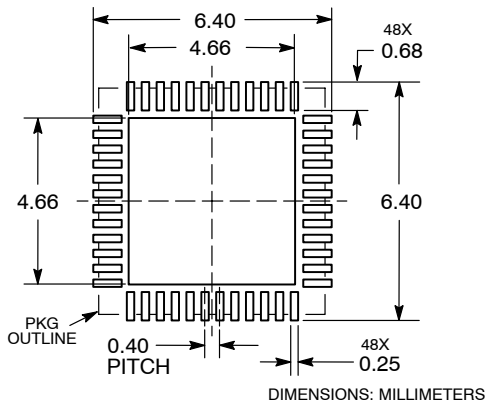

\*For additional information on our Pb-Free strategy and soldering details, please download the ON Semiconductor Soldering and Mounting Techniques Reference Manual, SOLDERRM/D.

<b>DOCUMENT NUMBER:</b>	<b>98AON39236E</b>	Electronic versions are uncontrolled except when accessed directly from the Document Repository. Printed versions are uncontrolled except when stamped "CONTROLLED COPY" in red.
<b>DESCRIPTION:</b>	<b>QFN48, 6x6, 0.4MM PITCH</b>	<b>PAGE 1 OF 1</b>

ON Semiconductor and are trademarks of Semiconductor Components Industries, LLC dba ON Semiconductor or its subsidiaries in the United States and/or other countries. ON Semiconductor reserves the right to make changes without further notice to any products herein. ON Semiconductor makes no warranty, representation or guarantee regarding the suitability of its products for any particular purpose, nor does ON Semiconductor assume any liability arising out of the application or use of any product or circuit, and specifically disclaims any and all liability, including without limitation special, consequential or incidental damages. ON Semiconductor does not convey any license under its patent rights nor the rights of others.

**onsemi**, **Onsemi**, and other names, marks, and brands are registered and/or common law trademarks of Semiconductor Components Industries, LLC dba "**onsemi**" or its affiliates and/or subsidiaries in the United States and/or other countries. **onsemi** owns the rights to a number of patents, trademarks, copyrights, trade secrets, and other intellectual property. A listing of **onsemi**'s product/patent coverage may be accessed at [www.onsemi.com/site/pdf/Patent-Marking.pdf](http://www.onsemi.com/site/pdf/Patent-Marking.pdf). **onsemi** reserves the right to make changes at any time to any products or information herein, without notice. The information herein is provided "as-is" and **onsemi** makes no warranty, representation or guarantee regarding the accuracy of the information, product features, availability, functionality, or suitability of its products for any particular purpose, nor does **onsemi** assume any liability arising out of the application or use of any product or circuit, and specifically disclaims any and all liability, including without limitation special, consequential or incidental damages. Buyer is responsible for its products and applications using **onsemi** products, including compliance with all laws, regulations and safety requirements or standards, regardless of any support or applications information provided by **onsemi**. "Typical" parameters which may be provided in **onsemi** data sheets and/or specifications can and do vary in different applications and actual performance may vary over time. All operating parameters, including "Typicals" must be validated for each customer application by customer's technical experts. **onsemi** does not convey any license under any of its intellectual property rights nor the rights of others. **onsemi** products are not designed, intended, or authorized for use as a critical component in life support systems or any FDA Class 3 medical devices or medical devices with a same or similar classification in a foreign jurisdiction or any devices intended for implantation in the human body. Should Buyer purchase or use **onsemi** products for any such unintended or unauthorized application, Buyer shall indemnify and hold **onsemi** and its officers, employees, subsidiaries, affiliates, and distributors harmless against all claims, costs, damages, and expenses, and reasonable attorney fees arising out of, directly or indirectly, any claim of personal injury or death associated with such unintended or unauthorized use, even if such claim alleges that **onsemi** was negligent regarding the design or manufacture of the part. **onsemi** is an Equal Opportunity/Affirmative Action Employer. This literature is subject to all applicable copyright laws and is not for resale in any manner.

## ADDITIONAL INFORMATION

### TECHNICAL PUBLICATIONS:

Technical Library: [www.onsemi.com/design/resources/technical-documentation](http://www.onsemi.com/design/resources/technical-documentation)  
onsemi Website: [www.onsemi.com](http://www.onsemi.com)

### ONLINE SUPPORT: [www.onsemi.com/support](http://www.onsemi.com/support)

For additional information, please contact your local Sales Representative at [www.onsemi.com/support/sales](http://www.onsemi.com/support/sales)