



**ON Semiconductor®**

# Effects of High Switching Frequency on Buck Regulators

---

# Abstract

The switching frequency is an operating parameter which affects nearly every performance characteristic of the supply, as well as the cost. Determining the proper switching frequency for a particular design requires that the designer knows the application sensitivity to each of these characteristics, in order to simultaneously minimize cost and satisfy all application requirements.

This presentation presents the effects of switching frequency on buck switching regulator operating characteristics, and how switching frequency affects the cost of the supply.



# Benefits of High Switching Frequency

1. Smaller converter
  - Smaller can be cheaper – up to a certain power output
  - Beyond that power level small size might be worth some added cost
2. Transient response can improve with higher switching frequency.
3. Avoids frequency bands in which noise would be disruptive
  - AM Broadcast
  - Vehicle motion/position monitors

# Drawbacks of High Switching Frequency

Efficiency is worse

Switching loss is proportional to switching frequency

FET Switch drive power is also proportional to frequency, and is usually provided by a Linear Regulator!

Maximum conversion ratio (maximum  $V_{IN}$ ) is lower

Dropout voltage (minimum  $V_{IN}$ ) is higher

Current limit accuracy is likely to be worse



# Output Filter Size & Cost

With higher ripple frequency, output filter inductor and/or capacitor values could be smaller, reducing total converter size and cost.

**For competing designs differing only in switching frequency:**

Inductor value is inversely proportional to switching frequency **for equal peak-to-peak ripple current**. But  $di/dt$  is then proportional to frequency, with impacts discussed later.

Capacitor value is inversely proportional to switching frequency **for equal output ripple voltage** (also assuming equal peak-to-peak ripple current). But capacitor ESR increases with decreasing capacitor value, with impacts discussed later.



# Inductor Size or Dissipation Reduction?

The **lower inductor value** permitted by higher frequency **has lower I<sup>2</sup>R loss** for the same core since the number of turns decreased.

But if thinner wire is also used, such that the DC resistance is not changed, using a core with a shorter mean magnetic path will result in a smaller volume inductor, with less core material experiencing the same loss per unit volume.

Example (Wurth WE-PD series)

Induct ( $\mu\text{H}$ )	Induct Ratio	Isat (A)	Volume ( $\text{mm}^2$ )	Volume Ratio	DCR ( $\text{m}\Omega$ )	Freq (kHz)	Freq Ratio	
4.7	1.00	3.9A	170.5	1.00	35	2000	5.00	S-type
22	4.68	3.8A	864	5.07	36	400	1.00	L-type

Powdered iron core loss is significant, and is proportional to frequency for the same peak flux level (same % saturation), so the above examples would have identical I<sup>2</sup>R and core losses, with inductor volume inversely proportional to frequency.

So inductor loss can be traded off for inductor volume, but **the product of loss and volume reductions cannot exceed the frequency increase factor.**

# Capacitor Size Reduction – Value Impact

The smaller capacitor value permitted by higher switching frequency increases the converter high frequency output impedance.

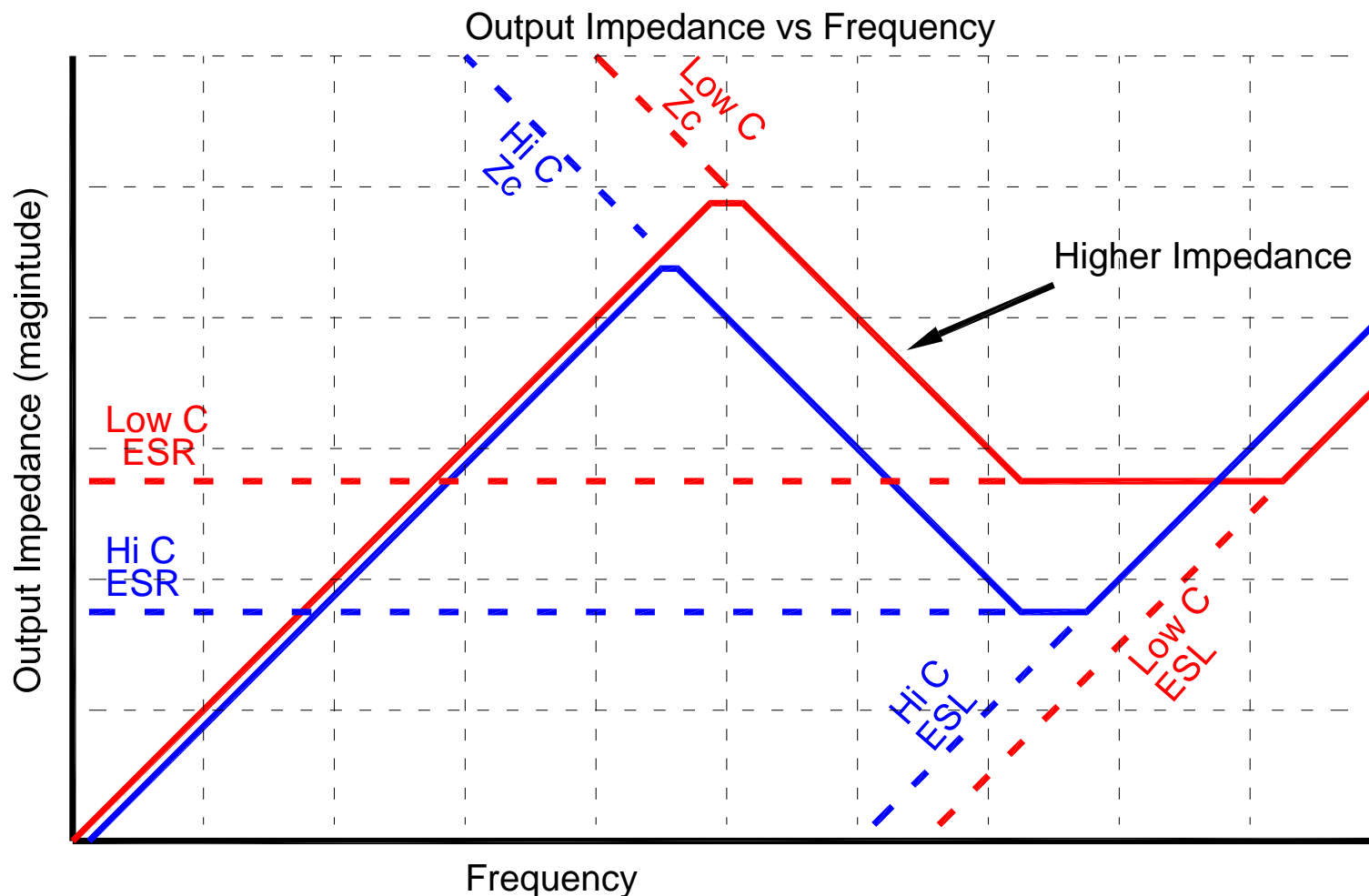

# Capacitor Size Reduction – ESR Impact

The smaller capacitor value permitted by higher switching frequency increases the converter high frequency output impedance – including at the switching frequency.

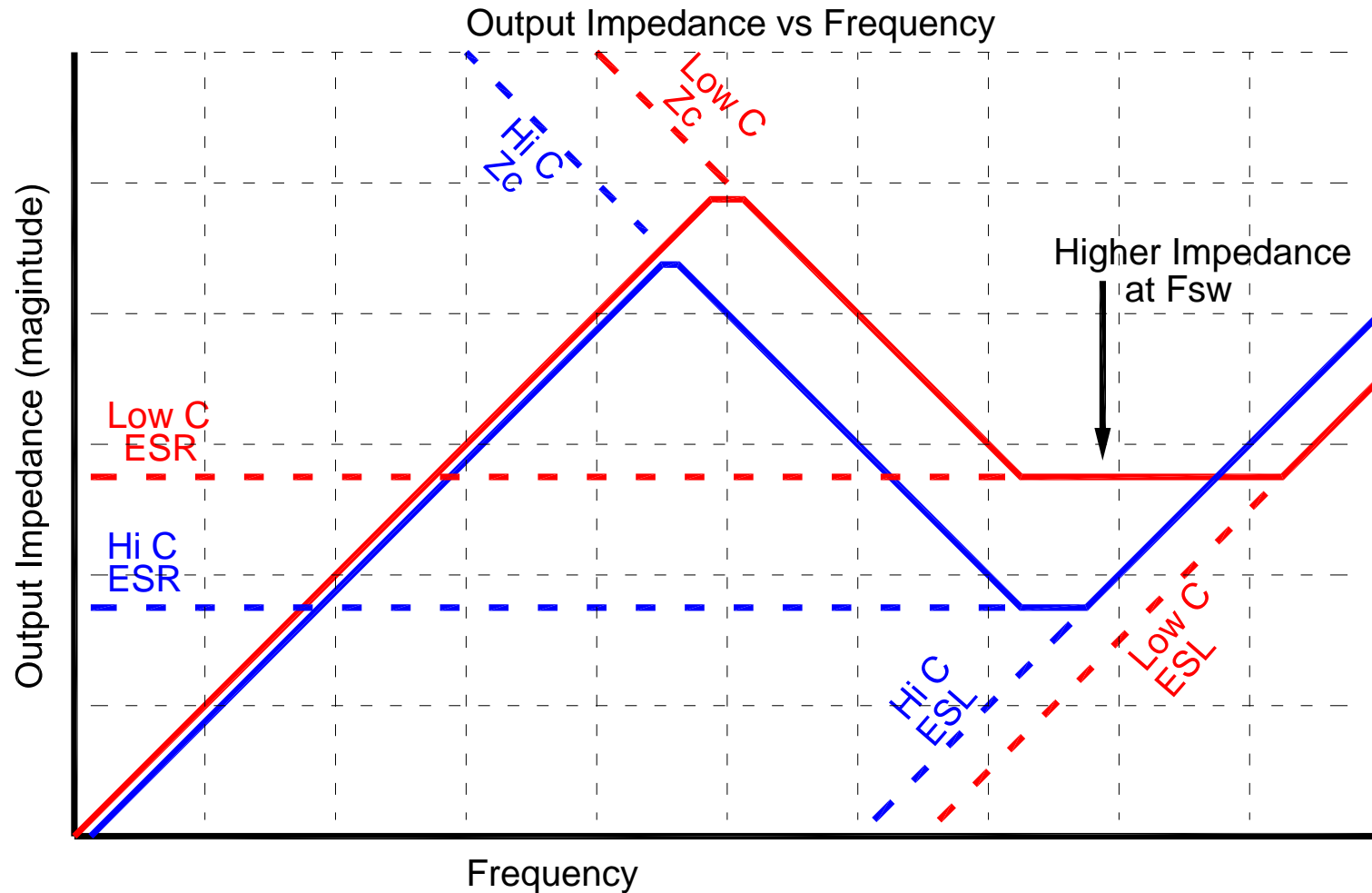

# Output Transient Performance

If the increase in high frequency output impedance shown in the previous slides is not a concern, or only the inductor value is decreased, the higher resonant frequency resulting from lower value output filter components does permit more of the Error Amplifier gain to be used to control output voltage at middle frequencies.

This improves mid-frequency transient response.

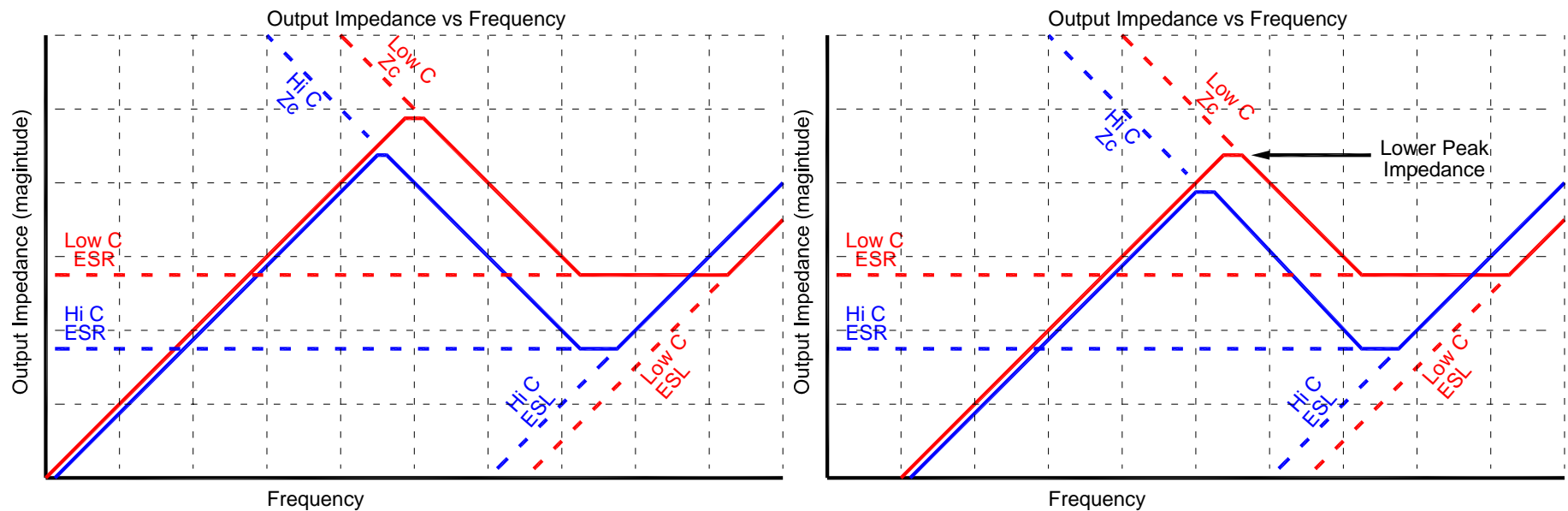



# Capacitor Size Reduction – ESR Impact

The **smaller capacitor** value permitted by higher switching frequency will typically have proportionally **higher ESR** for equally smaller case volume. But the relationship of ESR to case volume is highly variable, so must be carefully examined for the particular application.

Assuming an inversely proportional scaling of ESR with case volume, reaping the volume reduction afforded by higher switching frequency affects the output **ripple voltage** of the converter.



# Component Volume

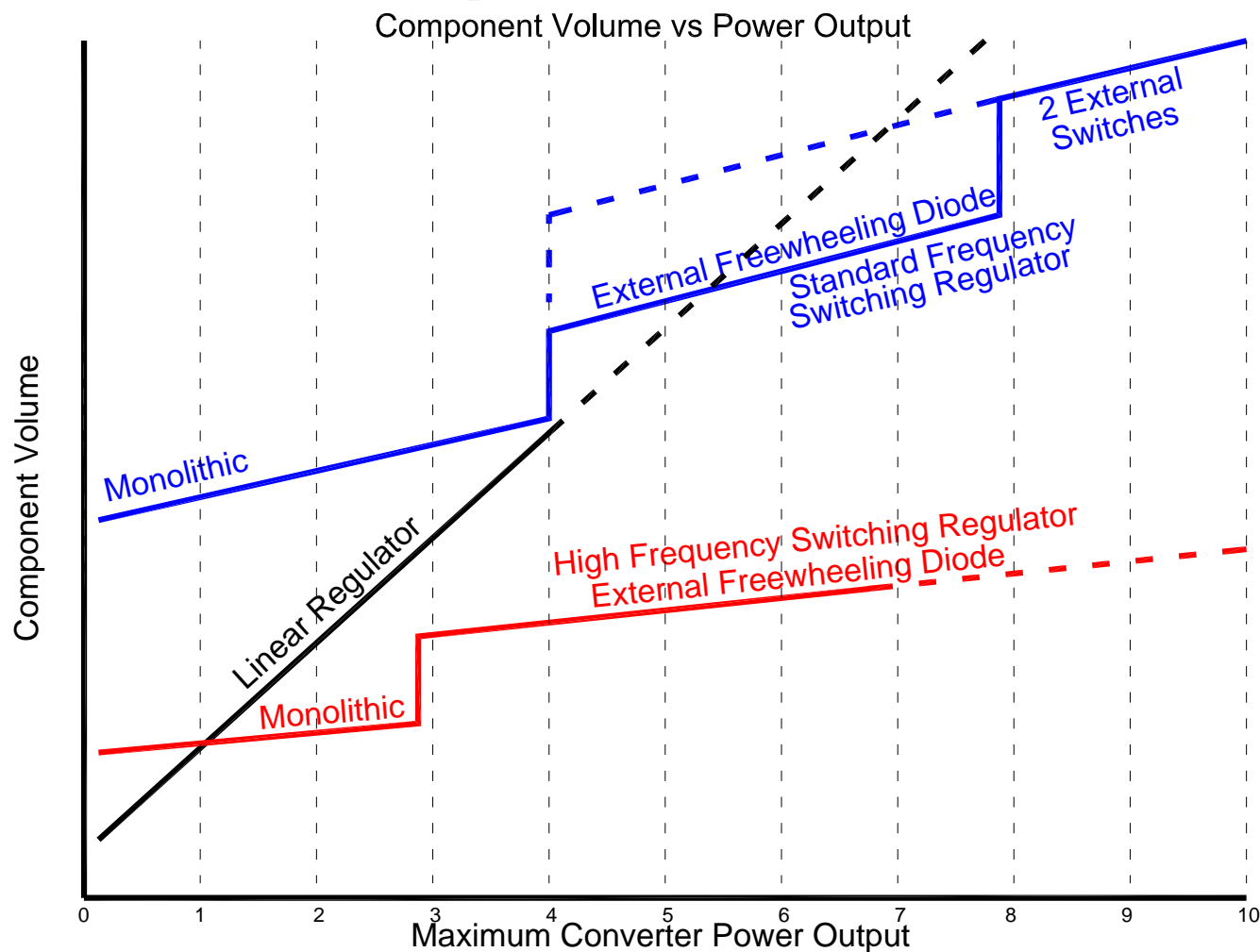

5:1 frequency ratio assumed for this graph.

Linear Regulator component volume reflects case size needed for cooling.

# Cooling Volume – Heatsinks, etc.

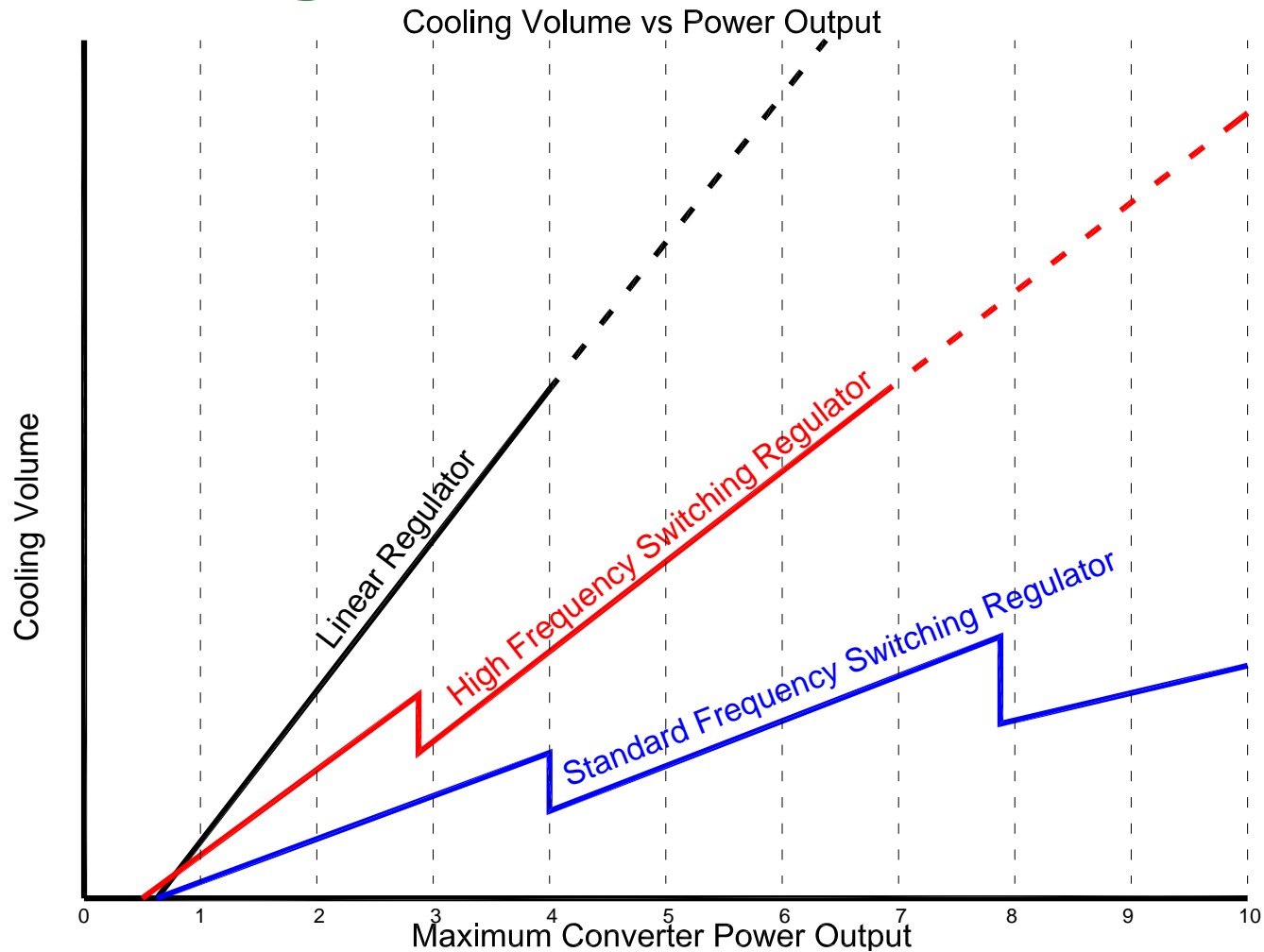

The same upper cooling volume limit is assumed for all regulators

# How Frequency Affects Total Converter Size

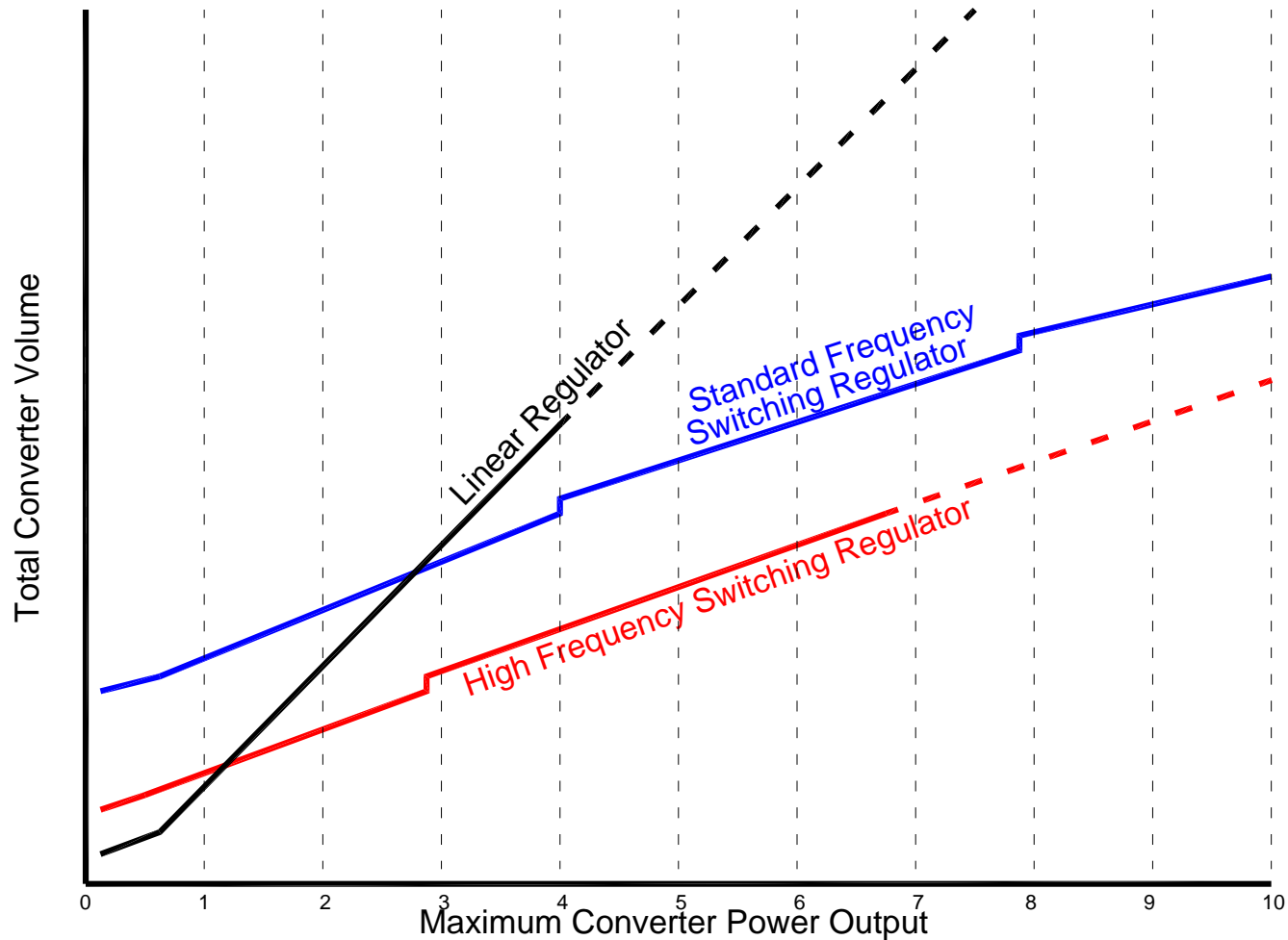

Sum of previous 2 graphs

---

# Efficiency

Switching loss increases with increasing switching frequency due to the greater number or constant energy switching events per time.

Besides this, if switching frequency is sufficiently high, Synchronous Rectification cannot be implemented – further increasing conduction loss for high conversion ratio applications.

Gate drive current also hurts efficiency – especially at high battery – unless bootstrapped from the output.



# Regulator Characteristics Determine Impacts

The impacts of high frequency switching depend on the answers to several questions:

1. Is the regulator using Voltage-mode or Current-mode to control output voltage?

Conversion ratio is limited for Current-mode control

2. Does the application need the efficiency of Synchronous Rectification?

If yes, then switching frequency or input voltage range will be restricted.

3. Is the regulator in Continuous Conduction mode (CCM) or Discontinuous Conduction mode (DCM)?

With DCM, light load switching frequency will decrease.



# Reduced Conversion Ratio (lower max VIN)

Current-mode converters typically have a blanking time, which sets the minimum D for a given Vout, and therefore max VIN, that will be regulated without reducing switching frequency (pulse skipping).

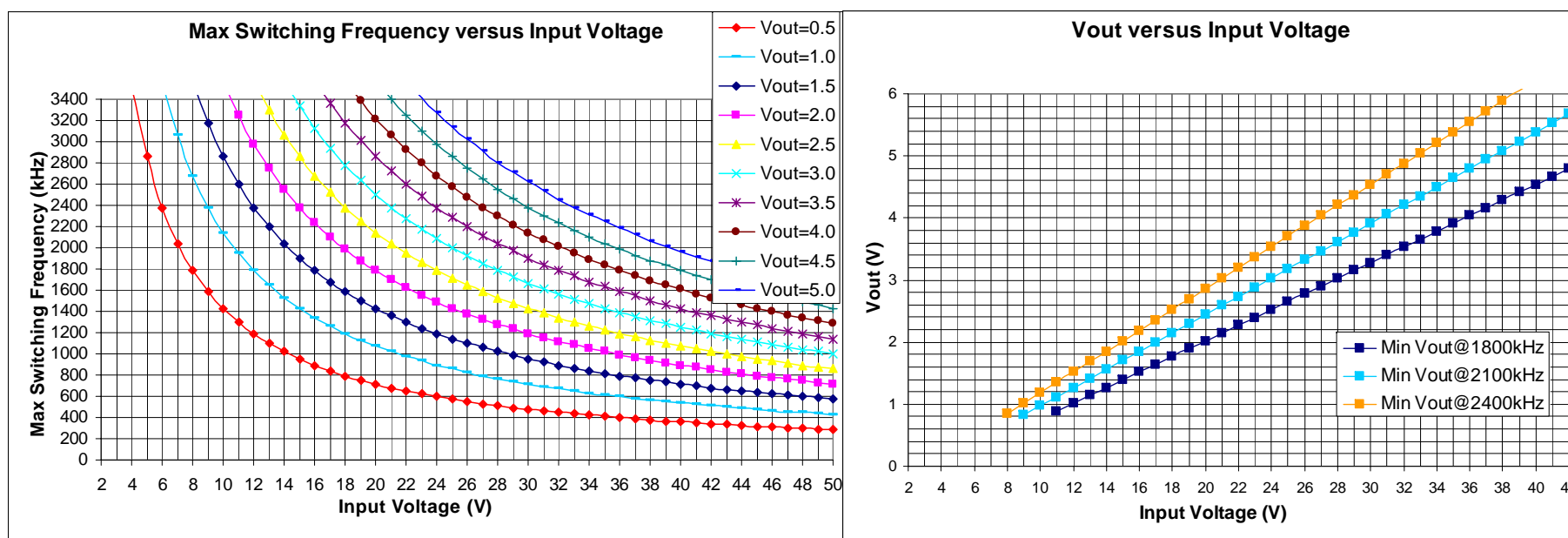

Graphs reflect 70ns blanking time.



# Reduced Conversion Ratio (lower max VIN)

As the load on a non-synchronous, current-mode buck converter approaches zero, the switching frequency will decrease in an irregular manner (pulse skipping) since a VIN-dependent charge must be delivered to the output during the blanking time at each turnon. For a given load current,  $F_{SWAVERAGE} = \text{Load current}/(VIN - Vout)$

Why be concerned with performance at loads <10% of max converter rating?

Loads will be in sleep mode some of the time

Bench evaluation should not exhibit pulse skipping over a wide load range

Even for output voltages that do not produce pulse skipping at high VIN, dissipation caused by Gate Drive current is high if the current is derived directly from VIN. Bootstrapping from the output can sometimes be used to avoid this excessive dissipation.





# Dropout Voltage (minimum VIN)

Dropout voltage = the minimum ( $V_{IN} - V_{out}$ ) that allows the switcher to maintain output voltage regulation

For a buck regulator,  $V_{out} = V_{IN} * D$  (Duty cycle =  $t_{on}/(t_{on} + t_{off})$ )

Therefore, dropout voltage =  $V_{IN} - V_{IN} * D$

Achieving D close to 1.0 minimizes dropout voltage, and minimizes the  $V_{IN}$  needed for regulation

Above light load (all buck regulators)

$t_{off}$  needed to recharge bootstrap capacitor is the sum of both non-overlap times + a short time to actually charge the bootstrap capacitor

# Dropout Voltage (minimum VIN)

Light load (non-synchronous buck, only)

For very light loads, the power switch 'OFF' time ( $t_{off}$ ) is required to be greater than some minimum needed to recharge the bootstrap capacitor. This minimum  $t_{off}$  varies inversely with load current. Since  $D = t_{on}/(t_{on} + t_{off})$ , this minimum  $t_{off}$  determines the maximum  $D$ , and thereby the minimum  $V_{IN}$  at a particular switching frequency. Expressed another way: for a given minimum load, the minimum  $V_{IN}$  is determined by the switching frequency.

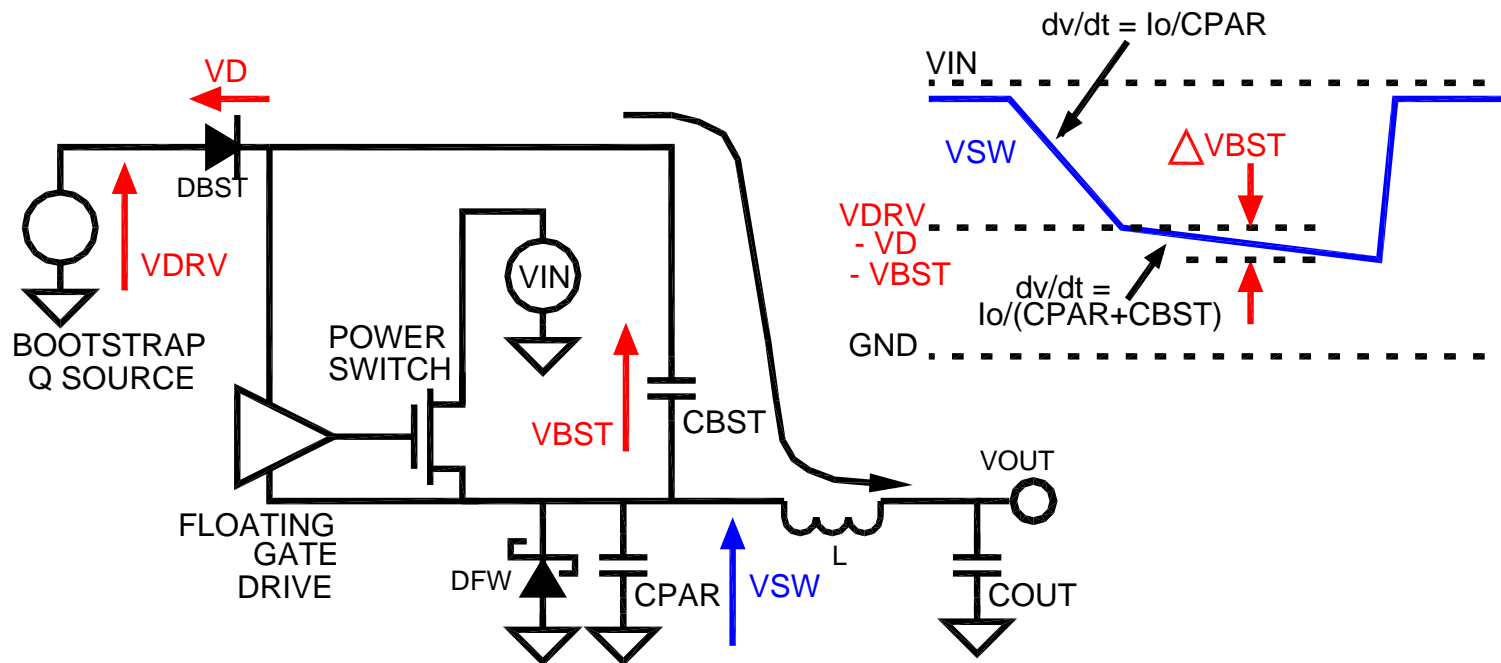

# Looser Current Limit

Lower inductor values increase the current limit variation due to the **current sense delay**. This is because  $V = L \, di/dt$ , or  $di = (V_{IN} - V_{OUT})/L \times dt$ :

1. The **bandwidth** of current monitoring circuitry causes delay

Delay is highly dependent upon overdrive, and consequently nearly independent on  $V_{IN}$  (higher  $di/dt$  is compensated by shorter delay)

2. Noise **blanking time** following switch turnon determines the shutoff delay during a dead short. The peak current limit is then proportional to  $di/dt$ .

$V_{IN}$  variation causes  $di/dt$  variation, causing average current to vary

$V_{out}$  droops when in current limit, increasing  $di/dt$  & raising average current



# EMC

There can be value in **pushing the switching frequency above sensitive bands**

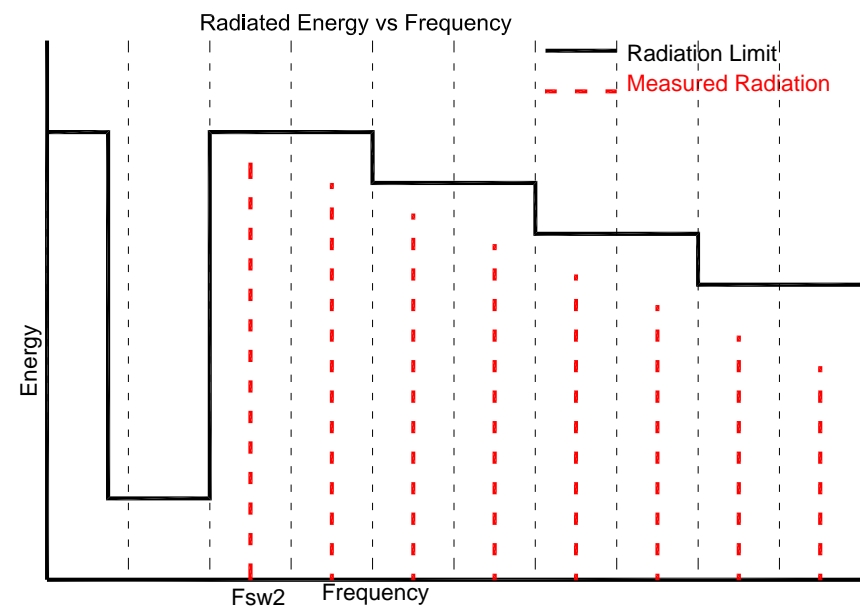
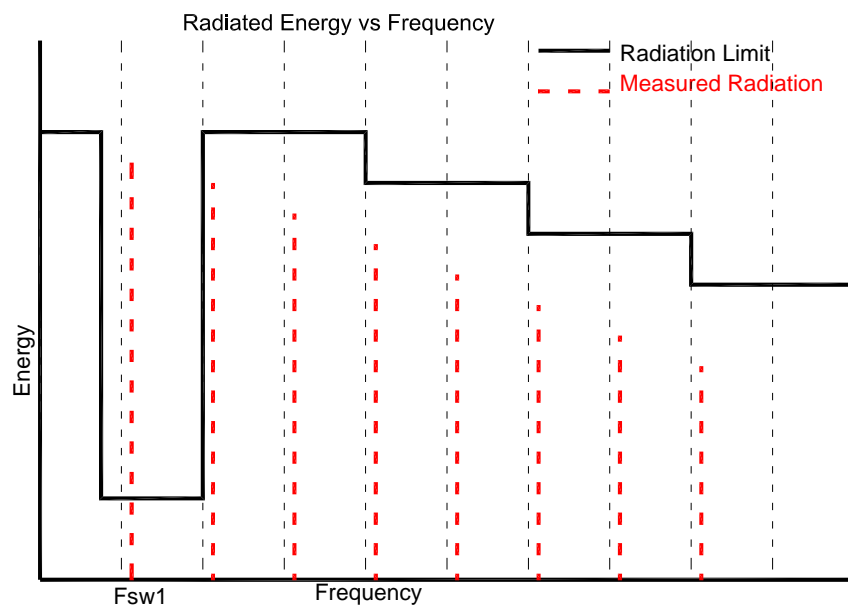

# EMC

## Too high a switching frequency can be worse

The energy at the fundamental frequency, and at each harmonic, does not change with switching frequency. But **emission limits get more restrictive at higher frequency.**

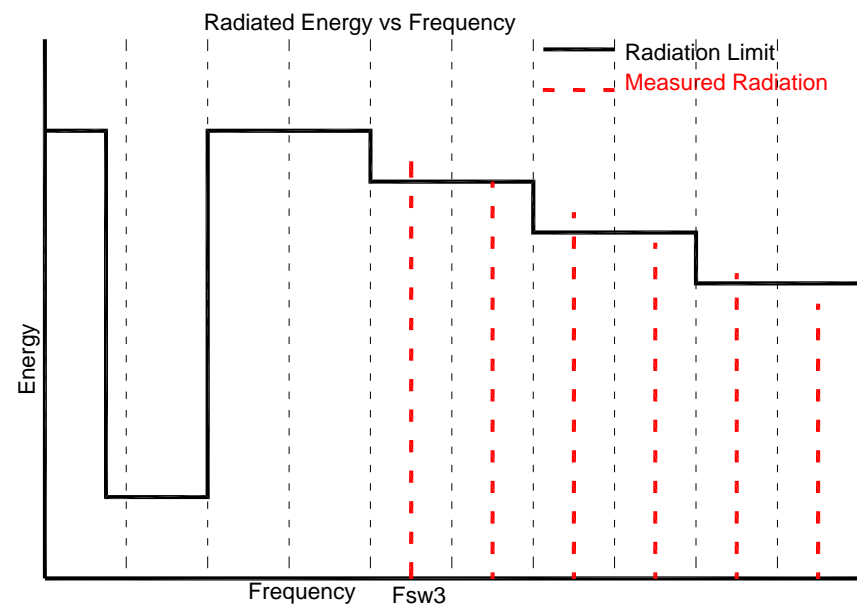
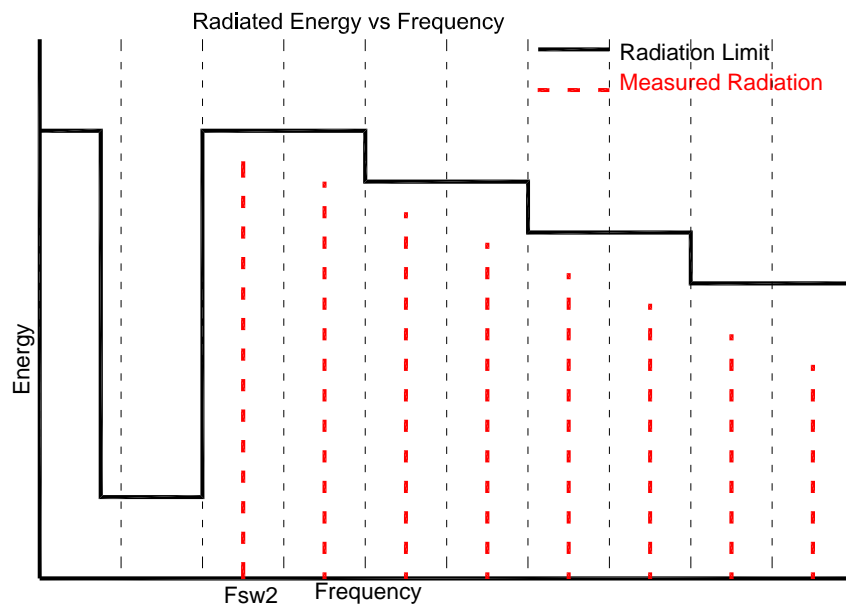

Less capacitance is needed to attenuate conducted noise at higher switching frequency, but **the ESR of the capacitors must remain low** – eroding some cost savings that might otherwise result from lower capacitance.

# EMC

**Synchronization** of the regulator to an **external clock** can help the fundamental and harmonics avoid a narrow frequency band of sensitivity.

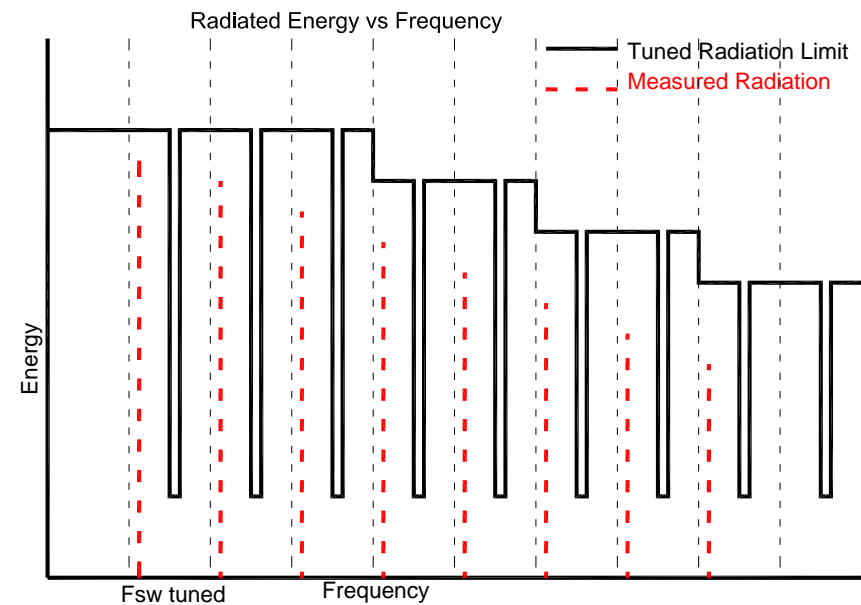
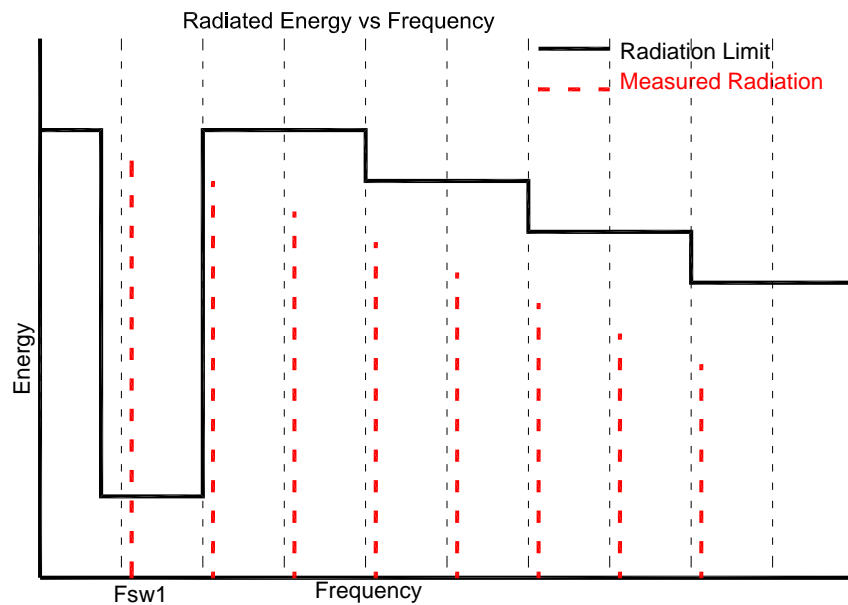

---

# References

ON Semiconductor Switchmode Power Supply Reference Manual Rev 2  
Apr-2000

Unitrode Application note U-68A



---

## For More Information

- View the extensive portfolio of power management products from ON Semiconductor at [www.onsemi.com](http://www.onsemi.com)
- View reference designs, design notes, and other material supporting automotive applications at [www.onsemi.com/automotive](http://www.onsemi.com/automotive)

