



ON Semiconductor

DN06017/D

Design Note – DN06017/D

Efficient, Low Cost, Low Standby Power (<100 mW), 2.5 W Cell Phone Charger

Device	Application	Input Voltage	Output Power	Topology	I/O Isolation
NCP1011	Cell Phone Charger	90 – 270 Vac	2.5 W	Flyback	Yes

Other Specifications				
	Output 1	Output 2	Output 3	Output 4
Output Voltage	5.0 V (adjustable)	N/A	N/A	N/A
Ripple	100 mV max	N/A	N/A	N/A
Nominal Current	500 mA	N/A	N/A	N/A
Max Current	620 mA	N/A	N/A	N/A
Min Current	Zero	N/A	N/A	N/A

PFC (Yes/No)	No
Minimum Efficiency	65%
Inrush Limiting / Fuse	Yes
Operating Temp. Range	0 to +50°C
Cooling Method/Supply Orientation	Convection
Signal Level Control	No

Others	Standby (no load) input power = 90 mW @ 230 Vac
---------------	---

Circuit Description

This design note features a very simple, yet highly effective low power cell phone charger designed around ON Semi's NCP1011 very high voltage switching regulator. The topology is a discontinuous mode flyback with a constant current – constant voltage (CCCV) output profile with better than 100 mA current regulation and 2 % voltage regulation. Plots of the efficiency curves and output current/voltage profile are shown on page 4 of this document. The circuit also includes an input pi filter for conducted EMI compliance. The existing circuit can easily be modified to accommodate other voltage and current combinations and is applicable up to 5 watts output if the NCP1014 is used for U1 with the appropriate rating and/or value changes to C4, D2, D5, R4 and R6.

Key Features

- Constant current – constant voltage output profile suitable Lithium Ion batteries
- Over-current, over-voltage and over-temperature protection
- Conducted EMI filter
- Simple half-wave input rectifier
- < 100 mW input standby power when auxiliary winding on transformer used
 - 90 mW @ 230 Vac
 - 75 mW @ 120 Vac
- Very low cost components
- Circuit easily tailored for other voltage/current combinations

DN06017/D

Schematic

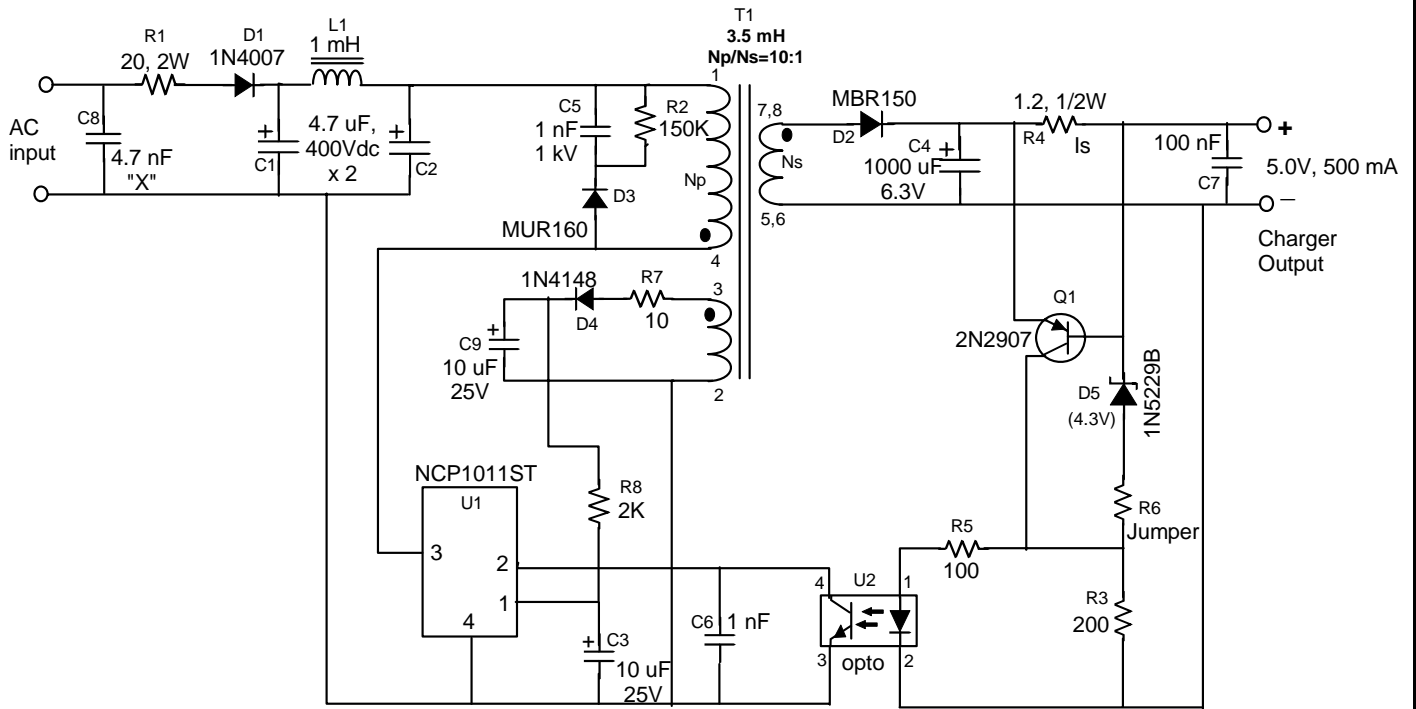

Notes:

1. D5 and R6 sets V_{out} ($R6 = \text{jumper for } 5V$; $R6$ increases voltage)
2. $R4$ sets I_{max} ($I_{max} = .65/R4$)
3. U1 is SOT223, 100 kHz version of NCP1011
4. L1 is Coilcraft RFB0807-102L (1 mH, 300 mA)
5. U2 is Vishay SFH-615A-4 or similar optocoupler

NCP1011 CVCC Cell Phone Charger
5.0 Vout, 500 mA

MAGNETICS DESIGN DATA SHEET

Project / Customer: ON Semiconductor - NCP1011/1014 Generic CP charger

Part Description: 5 watt flyback transformer, 4 - 9 volts out (REV 3)

Schematic ID: T1

Core Type: EF16 (E16/8/5); 3C90 material or similar

Core Gap: Gap for 3.5 mH

Inductance: 3.5 mH +/-5%

Bobbin Type: 8 pin horizontal mount for EF16

Windings (in order):

Winding # / type	Turns / Material / Gauge / Insulation Data
Vcc/Boost (2 - 3)	28 turns of #35HN spiral wound over 1 layer. Insulate with 1 layer of tape (500V insulation to next winding)
Primary (1 - 4)	150 turns of #35HN over 3 layers. Insulate for 3 kV to the next winding.
5V Secondary (5, 6 - 7, 8)	14 turns of #25HN spiral wound over one layer with 0.050" (1.3mm) end margins.

Vacuum varnish assembly.

Hipot: 3 kV from boost/primary to secondary for 1 minute.

Vendor for xfmr: Mesa Power Systems (Escondido, CA) part # 131296

Schematic

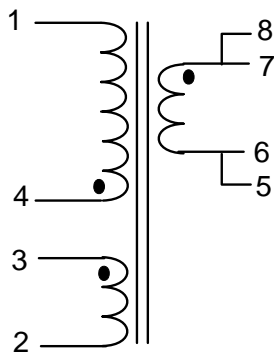

Lead Breakout / Pinout

(Bottom View - facing pins)

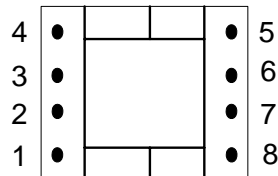

Test Results

Results

- Configuration: Half-wave input rectifier; no EMI inductor
- Transformer Np/Ns: 10:1; L_{primary} = 3.5 mH
- V_{out} nominal: 5.065 V
- Current limit : 530 mA (V_{out} at 4.90 V)
- I short circuit: 620 mA @ 120 Vac; 606 mA @ 230 Vac
- Vac regulation dropout: 85 Vac with 500 mA load; V_{out} = 4.90 V
- Output Ripple (500 mA load): 90 mV p/p
- Standby Input Power: < 100 mW
 - 90 mW @ 230 Vac
 - 75 mW @ 120 Vac

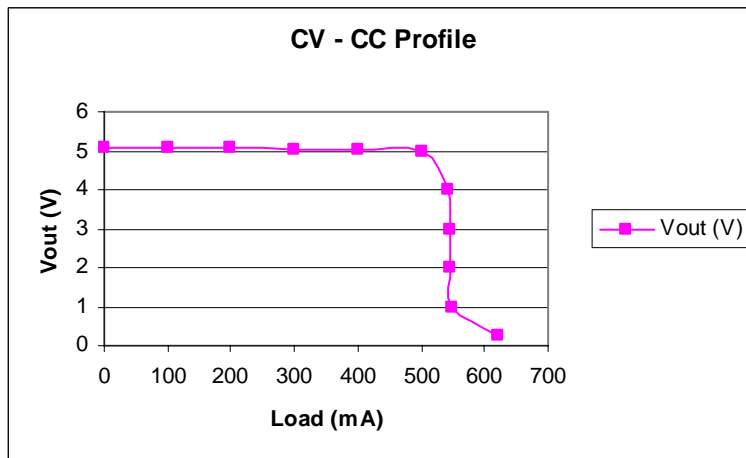
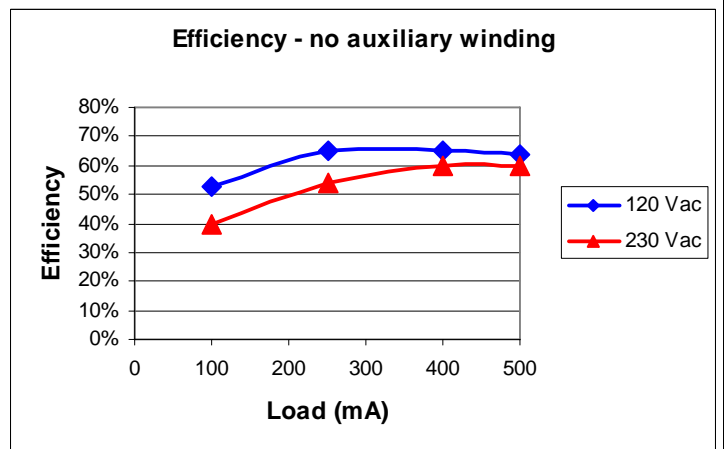
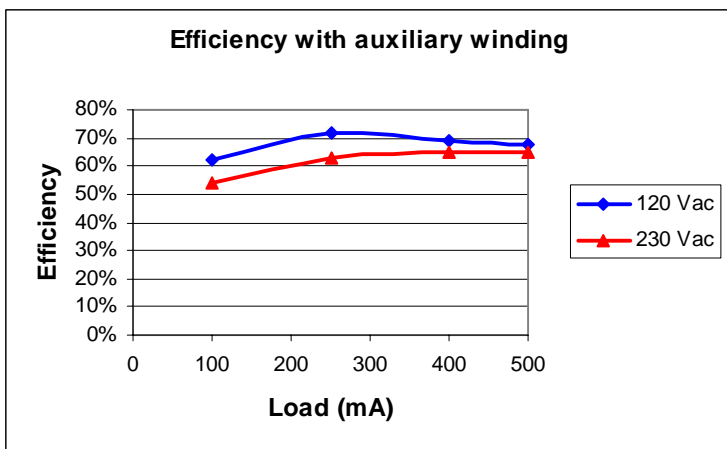

© 2006 ON Semiconductor.

Disclaimer: ON Semiconductor is providing this design note "AS IS" and does not assume any liability arising from its use; nor does ON Semiconductor convey any license to its or any third party's intellectual property rights. This document is provided only to assist customers in evaluation of the referenced circuit implementation and the recipient assumes all liability and risk associated with its use, including, but not limited to, compliance with all regulatory standards. ON Semiconductor may change any of its products at any time, without notice.

Design note created by Frank Cathell, e-mail: f.cathell@onsemi.com