

Power Supply Topology Selection – It’s Not Just About Power

By Frank Cathell, ON Semiconductor, Phoenix, Ariz.

When discussing power circuit topologies, most application notes, power component advertising charts, and power supply articles tend to imply that the selection of a given topology is dependent on the output-power level required by the application. Unfortunately, this criterion for topology selection is, by itself, generally insufficient and grossly oversimplified. Following such generalized criteria and advertising charts can lead to inadequate performance, low efficiency and unreliable designs in many cases.

Typical offline converter topologies are usually broken down into flyback, forward, half bridge, and full bridge in this order with ascending power levels. Exactly how the resonant converters fit into this selection template is usually not even mentioned or the explanation is vague at best. This article will address the additional specification elements and/or circuit subtleties of the more-common topologies that must be considered when attempting to properly determine the optimum converter topology. In some cases, the criteria discussed here may even be the most important factors in determining which topology best suits a given application.

Apart from power level, other important and even critical specification parameters include input voltage and range, output voltage/current levels, load type and characteristics, efficiency (this is where the resonant converters come in), isolation criteria, and magnetics volume utilization with respect to packaging density. The most-common isolated topologies (transformer coupled) will be addressed with their pros and cons based on the associated circuit idiosyncrasies and pertinent specification details. The major emphasis will be on the flyback and forward converter topologies since they are the most widely used. However, selection issues and circuit idiosyncrasies associated with the bidirectional converters (half bridge and full bridge) will also be addressed.

It should be noted that in some cases, nonoptimum topologies can be forced to provide the solution when one or more of the given specification parameters are extreme and carry more weight than the other parameters. For example, packaging-related mechanical constraints could dictate the use of an otherwise nonoptimum topology. The ultimate intent of this article is to highlight some of the more subtle yet important characteristics of the various topologies that, if not well understood, could result in a design selection that could ultimately be a “show stopper.”

Flyback Converters

For most applications with power levels below about a kilowatt, the flyback and forward converter topologies in one variation or another typically dominate. This is definitely the case for consumer and industrial applications in the 350-W range and below. In these supplies, a power factor correction stage ahead of the main converter is usually mandatory to meet agency compliance (IEC61000-3-2) for total harmonic distortion (THD) and electromagnetic interference (EMI)-related mains emissions.

Single-Switch Flyback

The “pro” factor that singly defines this topology is simplicity (with accompanying low cost!), and that is why it is so popular. And, when properly applied, it “gets the job done” very effectively. The schematic of this simple topology is shown in Figure 1.

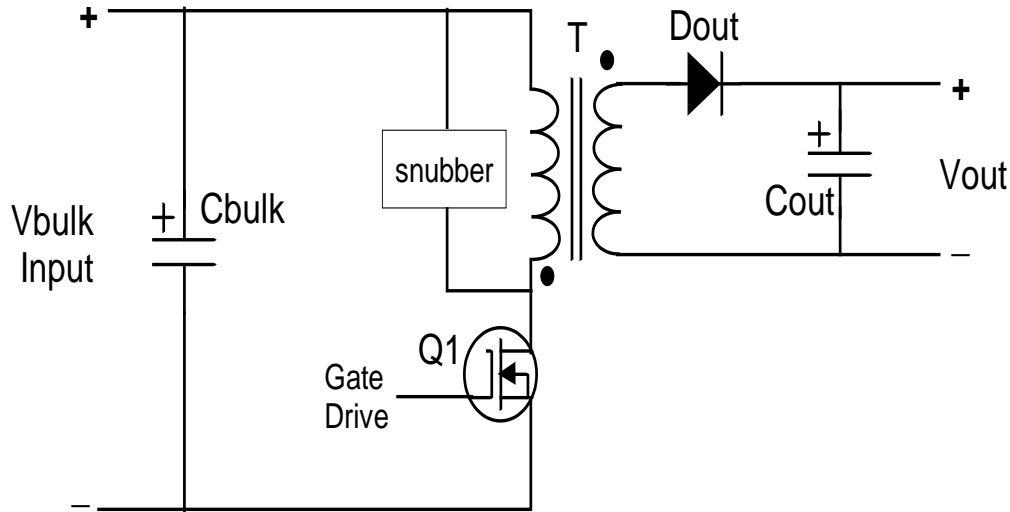

Figure 1: Basic single-switch flyback converter.

The dominant characteristics of the single-switch flyback converter and its limitations are as follows:

The “heart” of the flyback circuit is the flyback “transformer” design. In fact, “transformer” is a misnomer because it is really an energy-storage choke with a secondary winding. The secondary winding merely performs a voltage or current translation when the MOSFET switch is turned off so as to optimize the voltage and current stresses on both the MOSFET and the secondary output diode. It, by no means, functions like the transformer in a forward or bidirectional converter topology. It also provides galvanic isolation between the primary and secondary parts of the circuitry.

Because of the energy-transfer characteristic of the flyback transformer, the output appears as a relatively high impedance source. As a result, the flyback topology is better when producing power via a high-voltage, low-current output rather than a high-current, low-voltage output. This is not to say that a moderately high-current, low-voltage output (for example, a 5-V, 5-A output) is not feasible. However, output currents much more than this will significantly impact secondary component selection and related costs due to high peak-to-average current ratios and a resultant high rms ripple current through the output capacitors.

This high inherent-ripple current will also manifest itself as a high ripple voltage unless a pi-network output ripple filter is utilized. Assuming a typical 50% switching duty ratio in the converter, the rms current ripple through the output capacitor can be shown to be approximately 1.6 times the dc output current. So this means that the output capacitor (or capacitors in this case!) must be able to handle a ripple current of 8 A rms for a 5-A dc output. This definitely forces the output capacitors to have low equivalent series resistance (ESR) to avoid internal heating due to the ripple reflected across the ESR.

For typical low-impedance radial-leaded capacitors, this requirement would imply the use of at least five or more capacitors if high reliability is to be expected. Low-ESR multilayer ceramics are another option. However, the cost will be greater and they will still need an electrolytic with sufficient output capacity to keep the overall output impedance of the converter low for loop stability. For a 5-V, 10-A supply, the forward converter would definitely be more appropriate.

The flyback transformer’s primary-leakage-inductance parameter is probably the most significant detriment to flyback energy transfer and should be minimized. Leakage inductance can be defined as magnetic flux created by the primary when the MOSFET switch is on that never couples to the secondary when the MOSFET switch turns off. As a consequence, this energy must go somewhere and usually manifests itself as a voltage spike across the primary that can exceed the voltage rating of the MOSFET if some type of snubber circuit is not used. This is particularly a major problem in the single-switch flyback configuration of Figure 1.

Leakage inductance is affected by two parameters; the core winding geometry and the number of turns squared (N^2) on the primary and secondary windings. The winding geometry refers to the manner in which the primary turns and secondary turns are positioned with respect to one another. Lowest leakage inductance occurs when any of the following are true: The primary and secondary are in single layers and cover the entire bobbin winding width with close wound turns; the secondary lies directly on top of the primary (or vice versa) with

minimal insulation separation between the two; and the minimum number of primary turns is used assuming the core cross-sectional area and maximum flux-density criteria are met.

Needless to say, the requirements of most of these parameters conflict with one another when meeting safety agency requirements; maintaining a minimal core size; and using inexpensive winding techniques. Typically optimizing any one for a given design compromises the others. So the transformer design becomes a significant compromise of parameters in most designs, and some level of leakage inductance is always present. Several winding configurations and their associated leakage inductances are shown below (Figure 2).

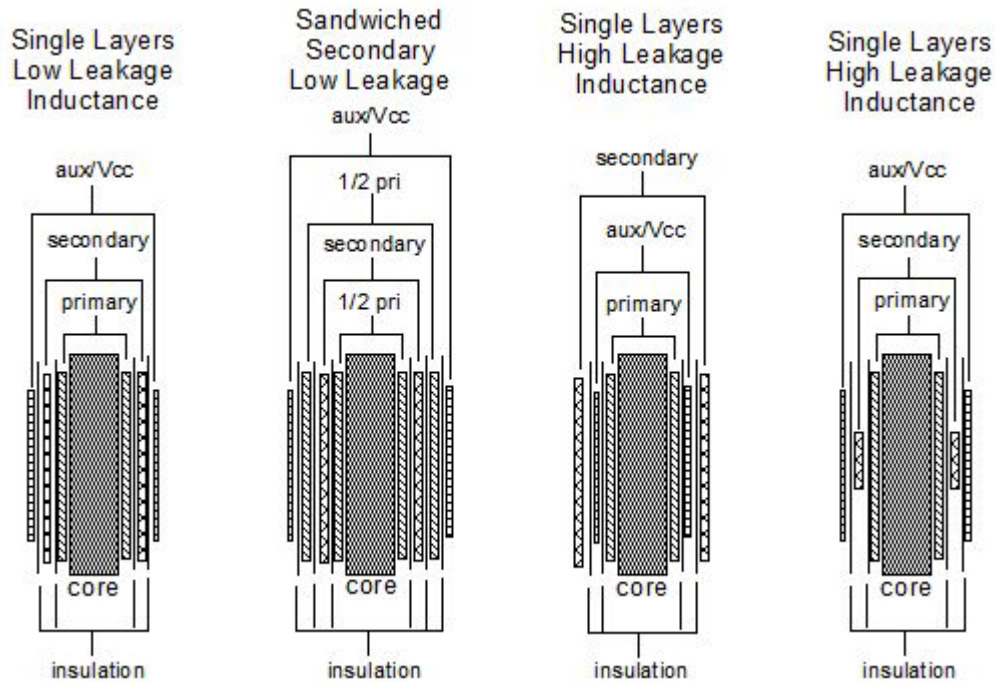

Fig 2. Winding configurations and associated leakage inductances.

The peak-to-average current ratios are higher in the flyback topology than most others (some zero-voltage-switching resonant designs can be similar). This requires MOSFETs and output rectifiers that can efficiently handle the high peak currents involved. Depending on the flyback mode of operation (explained later), peak MOSFET currents will typically be 1.5 to 2 times that of equivalent-power forward converter and half-bridge topologies. Peak current through the output rectifier will be 3 to 4 times the dc output current depending on the flyback operational mode (explained later) and duty ratio.

Two-Switch Flyback

In cases where the transformer leakage inductance cannot be managed sufficiently by a reasonable snubber design or some type of resonant approach (e.g. active clamp flyback), the two-switch flyback circuit of Figure 3 may be appropriate. Due to the two-switch implementation along with commutating diodes D1 and D2, this topology will clamp any leakage-inductance-generated voltage spikes to the dc input bulk voltage level.

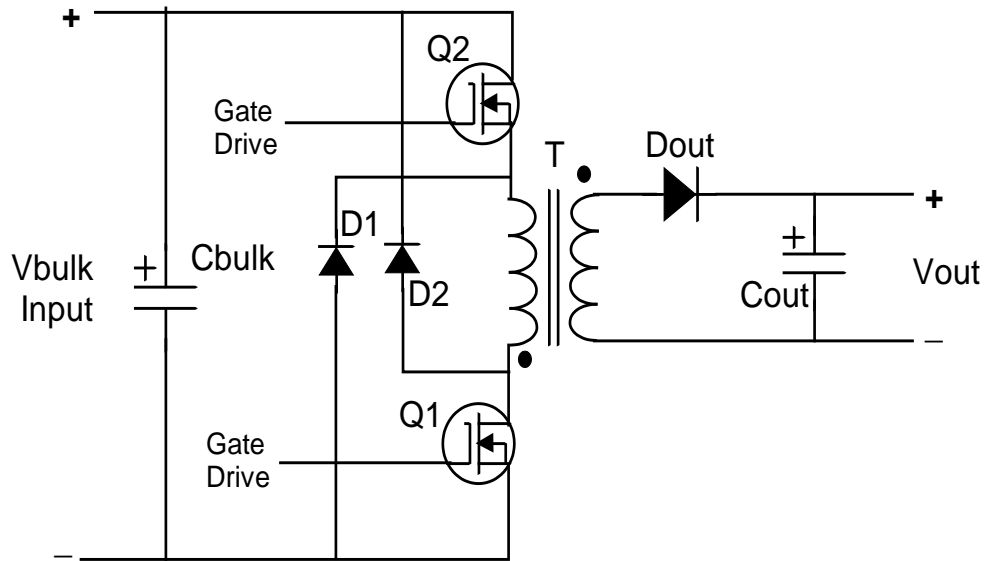

Figure 3. Basic two-switch flyback converter.

The MOSFET's voltage rating can also be reduced and typically the on-state losses of the two switches in series will be equivalent to or less than a single, higher-voltage device. The leakage inductance energy is essentially recycled back to the input capacitor. The tradeoff is a more-complex circuit in terms of gate drive, component count, and, the duty ratio is strictly limited to less than 50% because the volt-second product of the core must be balanced to prevent flux saturation.

The turns ratio must also be chosen such that the flyback voltage on the secondary must reach the secondary dc output voltage level before the reflected primary voltage reaches the minimum bulk-voltage level and causes the commutating diodes D1 and D2 to conduct. Otherwise the flyback energy will be transferred right back to the bulk input capacitor instead of the output.

Either flyback topology can be operated in one of two modes, discontinuous-conduction mode (DCM), and continuous-conduction mode (CCM). There is another mode that has become popular and this mode is a special case of DCM, usually referred to as critical-conduction mode (CRM) or borderline-conduction mode (BCM, also known as boundary-conduction mode). It is a compromise mode at the boundary of CCM and DCM with some interesting benefits and is normally implemented in the single-switch flyback.

It is instructive to review the characteristics of each of these modes so that an appropriate selection can be made for the application. In DCM, the inductor secondary current is allowed to go to zero after the previous "on" period before the main MOSFET switch Q1 turns back on again. In fact, there is even a "dead-time" in which no current is flowing in any part of the converter circuitry. In CCM mode, the main MOSFET switch turns on before the current in the secondary has ceased to flow. Both of these modes operate at a fixed switching frequency.

CRM operates right at the boundary between DCM and CCM, but still has the principle characteristics of DCM except there is never any "dead time" period and the switching frequency must be variable to accommodate both the variable MOSFET on- and off-times dictated by the controller and transformer core-reset period, respectively. This is essentially a free-running mode in which the switching frequency is determined by the primary inductance and peak current set-point in the control IC.

Figure 4 shows the relationship between the waveforms on the MOSFET drain voltage for DCM, CCM and CRM/BCM. Note that when operating in CRM/BCM, if the MOSFET is forced to turn on in the "valley" of the first ring out after core-energy depletion, the switch essentially sees the lowest voltage on the drain, thus minimizing turn-on losses. This is essentially a quasi-resonant (QR) mode that is typical for CRM/BCM which will enhance efficiency by lowering MOSFET switching losses. This technique is sometimes called "valley switching", and is an excellent way to maximize overall-converter efficiency. The converter derives all the benefits of DCM switching and is fully optimized for this mode.

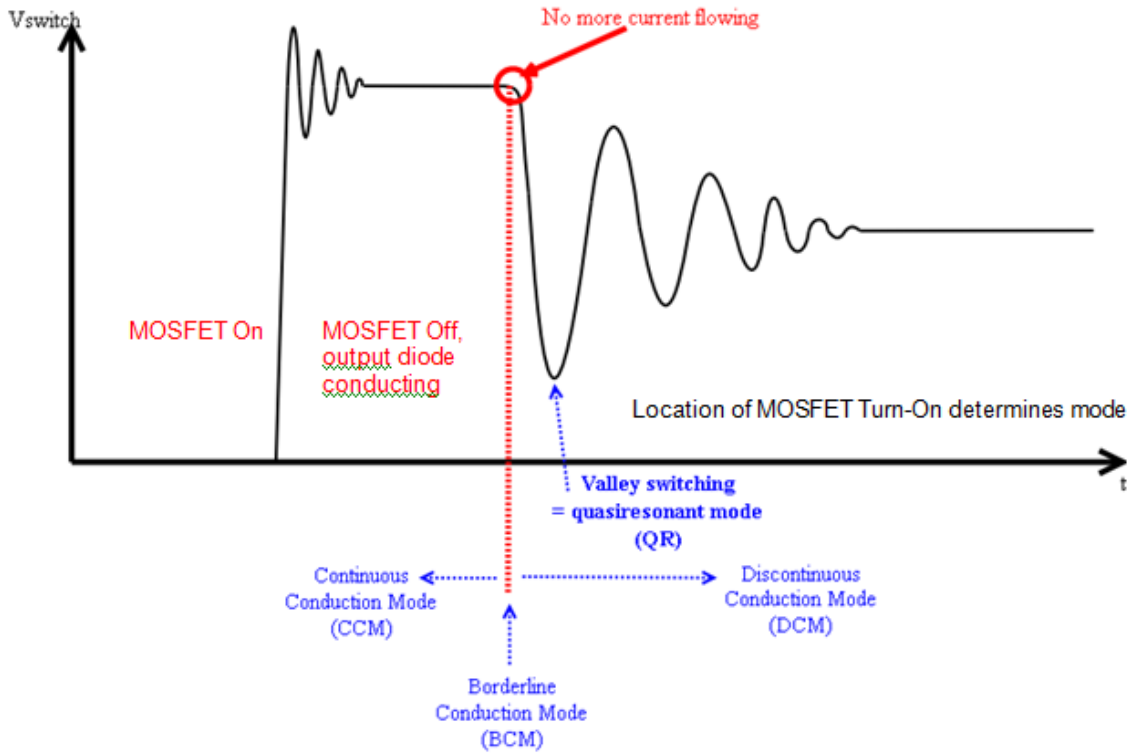

Figure 4. MOSFET turn-on with respect to drain voltage.

Some oscilloscope plots of the MOSFET drain switching waveforms in a 60-W converter are shown in blue in Figures 4, 5 and 6 illustrating each flyback mode. It should be noted that at light loads, CCM will always transition into DCM due to the lower inductor current allowing the energy to “dry out” sooner. The MOSFET gate-drive voltage is shown in orange for reference.

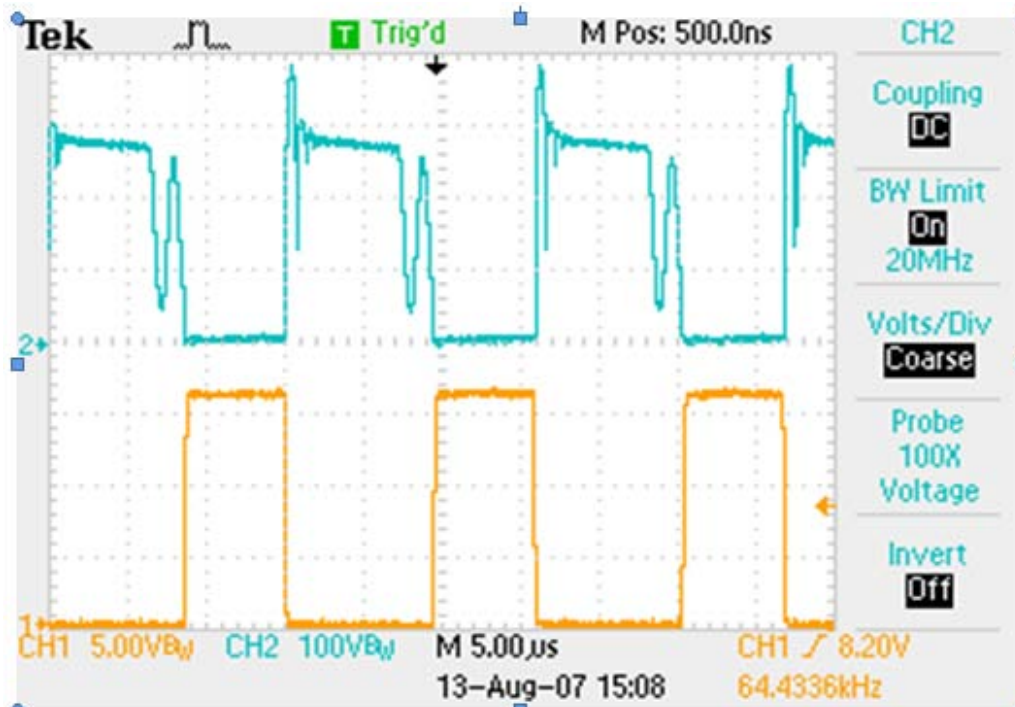

Figure 5. Drain voltage—DCM.



Figure 6. Drain voltage—CCM.

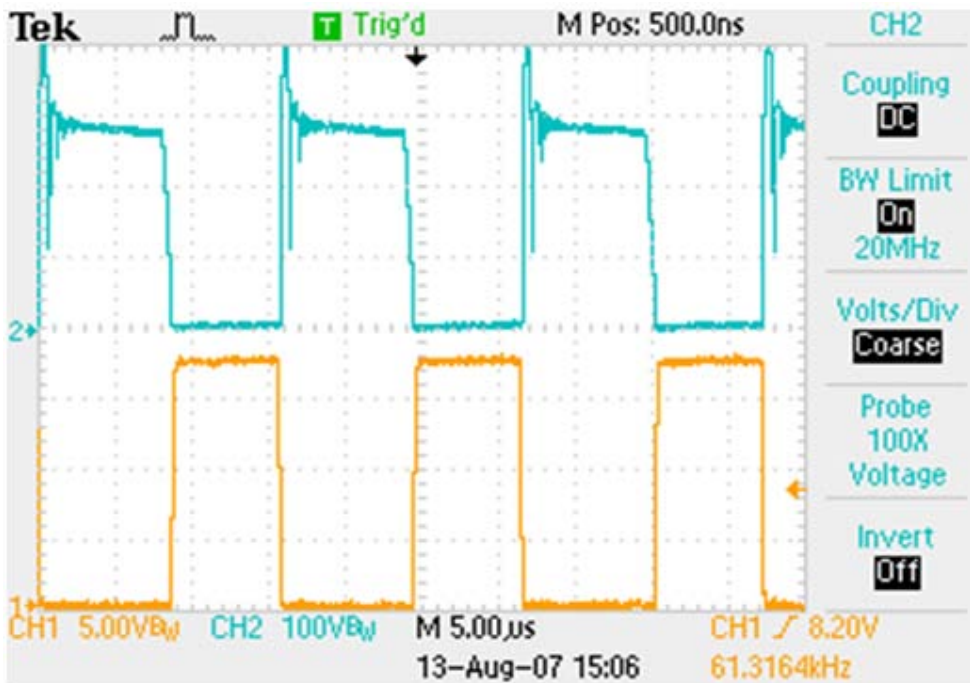

Figure 7. Drain voltage—CRM/BCM.

The benefits and disadvantages of each of these flyback operation modes can now be summarized and compared.

DCM Flyback

This is the simplest mode to implement and can operate at a fixed switching frequency. The output has a single-pole characteristic, which will allow for a relatively wide bandwidth and feedback loop that is easy to compensate. The transformer will typically be the smallest of the three implementation modes due to the lowest requirement for primary inductance. This usually results in easier transformer design with low leakage

inductance assuming the secondary is not intended for low-voltage, high-output-current applications. Also, the current in the output diode will naturally go to zero before the main MOSFET turns back on, thus eliminating any diode switching noise or recovery losses incurred by forced reverse recovery.

Unfortunately, DCM has the highest peak-to-average current ratio of all of the three flyback modes of operation. This necessitates the use of a MOSFET and output diode with higher current ratings, and the rms ripple current through the output capacitors is highest, which obviously necessitates good quality, low-ESR capacitors. This is a good choice for the lowest-power applications (~ 100 W or less) if component cost is a mitigating issue. For high-voltage-output applications, the DCM topology can be utilized effectively to several hundred watts and kilovolt outputs with proper power-component selection.

CRM/BCM Flyback

This implementation is essentially an “optimized” DCM flyback in which the lack of any significant deadtime between MOSFET and output-diode conduction periods minimizes the peak-to-average current ratio for DCM. The transformer size may be slightly larger (more turns) than the pure DCM implementation so as to accommodate the lowest switching frequency, which will occur at max load and lowest Vdc bulk input. The ability to use valley switching along with no output-diode recovery losses makes this a very efficient approach for most low-output-current applications.

The fact that the switching frequency varies may be of concern for some people because of EMI filtering; however, experience has shown this not to be a significant issue. In fact, the overall lower switching losses typically mean lower EMI generation. Another significant advantage to CRM/BCM is that output synchronous rectifier implementation is very easy and allows further efficiency enhancement. The variable switching frequency, however, may not be suitable for applications in which the switching frequency is required to be synchronized to an external clock source.

CCM Flyback

This approach should be used if the lowest possible peak-to-average current ratios are required in the MOSFET and output diode, and minimal output-capacitor ripple current is desired. In some low-power (< 20 W) applications, such as converters using monolithic controller/MOSFET IC combos, this mode may improve efficiencies by keeping the internal MOSFET's peak current minimized. This mode does have a price, particularly if used in higher power (> 100 W) flyback circuits. Since the current is still flowing in the output diode when the MOSFET turns back on, the diode is force-commutated off.

Ultrafast diodes used in the output can generate considerable high-frequency noise during the reverse-recovery period. “Soft recovery” and/or Schottky diodes are recommended, if at all possible. The MOSFET also has a leading-edge current step on it, which can also contribute to additional switching noise and switching losses. The most undesirable feature of CCM is the right half-plane zero in the topology transfer function. This will usually necessitate a more elaborate loop-compensation scheme with lower bandwidth, which can affect output transient response.

Another issue associated with CCM is that ramp compensation to the current-sense input in a current-mode type controller is necessary to prevent subharmonic oscillations if the duty ratio exceeds 50%. To keep the inductor current in the continuous mode (either in the primary or secondary) for the typical load range, a high primary inductance is needed. This necessitates a larger transformer (more primary turns) than would be required for an equivalent DCM or CRM design.

Synchronous Output Rectifiers

A comment is in order concerning the use of MOSFET synchronous output rectifiers in flyback topologies. The DCM implementation will almost invariably transition to CCM during an overload condition or at initial startup when the output capacitors are being charged. Likewise CCM will transition to DCM at some point with decreasing output load. As a consequence of these mode transitions, the sensing and timing criteria necessary to effectively implement synchronous rectifiers can become rather complex circuit wise, and will typically require signal processing derived from the primary-side MOSFET's gate-drive signal.

With CRM/BCM, all that is necessary to properly control the synchronous rectifier MOSFET is a simple sensing scheme that detects when current is flowing in the secondary. Since there can be no mode transitions in CRM/BCM, none of the critical timing circuitry required by DCM or CCM is necessary and the design can maintain simplicity and low cost.

Forward Converters

The forward converter is essentially a buck converter in which a unidirectional pulse transformer has been added to provide both primary-to-secondary isolation and a means of voltage conversion via the transformer turns ratio. Figure 8 shows the typical forward-converter transformer and associated secondary circuitry, which includes the secondary forward rectifier Dfwd, and the typical buck output section consisting of an L/C output filter and freewheeling diode Dfrw.

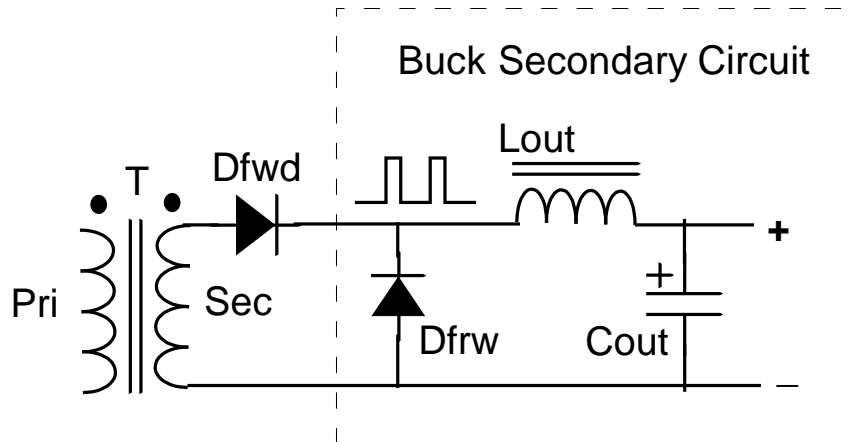

Figure 8. Forward secondary buck circuit.

Note how the forward transformer polarity dots differ from the flyback transformer topologies mentioned above. Because the forward converter relies on unidirectional pulses through the transformer, the operational duty ratio (D) is usually limited to less than 50% in the more-common implementations. This forces the transformer core flux to reset each switching cycle by allowing the volt-second product to equalize during power switch off- and on-times.

The primary side of the forward converter circuit can take several forms depending on the ac or dc input parameters, the allowable voltage and current stresses on the switching MOSFETs, and the desired circuit complexity to achieve optimum transformer reset, and voltage spike and EMI management.

Single-switch Forward With Reset Winding

Figure 9 shows the single-switch forward converter implementation with required reset winding on the transformer. This winding causes the voltage across the primary to reach a level, which allows transformer-core reset during the off-time of the MOSFET. Assuming a 1:1 turns ratio between the primary and the reset winding (typical implementation), the maximum primary duty ratio will be limited to less than 50% to assure reset, and, the maximum voltage the MOSFET drain will see will be twice Vdc input plus a small leakage-inductance spike. Neglecting the voltage spike, the reset diode clamps the drain voltage to twice Vdc bulk input.

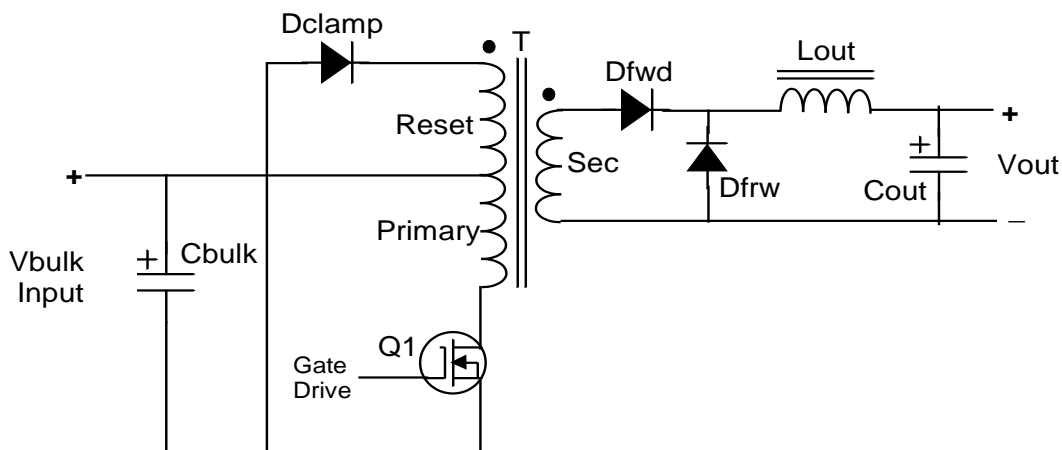

Figure 9. Forward converter with transformer-reset winding.

The voltage spike is associated with the leakage inductance between the primary and the reset windings and will necessitate a bifilar winding technique for the transformer to keep the leakage inductance minimal. This single-switch configuration is not generally applicable to universal-input offline applications where the MOSFET peak drain voltage will approach 800 V. A 1-kV rated device would be necessary here for any design margin. As a consequence, this particular forward-converter topology is used mostly in 120-V ac input and 48-V dc input (and lower) telecom applications where the peak MOSFET voltage falls in a more manageable range.

Note that even for 120-V ac input, a 500-V dc rated part should be required ($135 \text{ V ac max} \times 1.4 \times 2 = 378 \text{ V pk} + \text{spike}$.) This configuration will require winding the reset and main primary in a bifilar manner on the transformer bobbin. For ease and symmetry of winding, both wires should be the same size (diameter) and determined by the primary rms current. This invariably makes the reset-winding wire size really excessive for the small currents carried by this winding, and can potentially force a larger-than-desired core to be used to accommodate the required primary/reset turns.

Single Switch With Snubber Reset

This single-switch configuration is shown in Figure 10. In this case a snubber network (D_s , R_s , C_{clamp}) is used to “soften” and ultimately clamp the voltage rise on the MOSFET drain during core reset by means of a passive clamp capacitor. This scheme lessens the cost of the extra winding on the transformer, and can result in the use of a smaller core, but at the expense of power dissipation in the snubber resistor R_s , which discharges the clamp/reset capacitor each switching cycle.

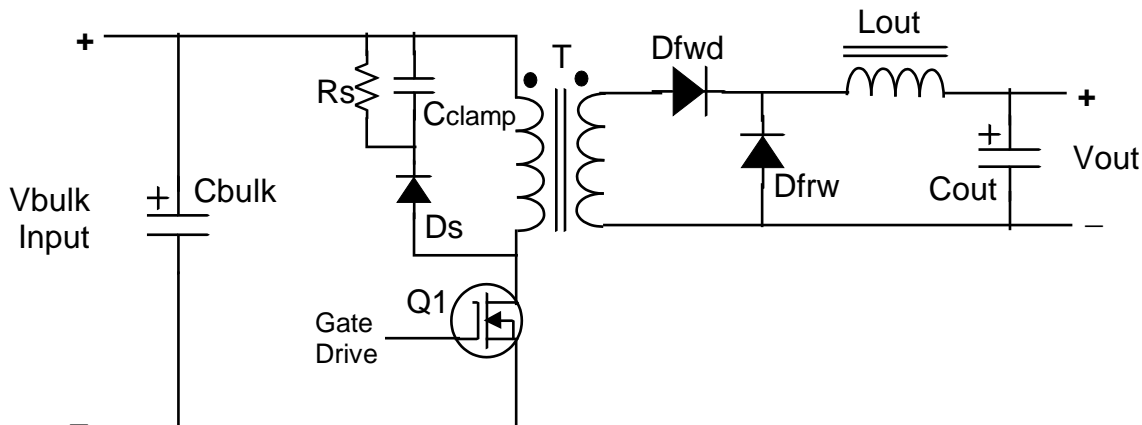

Figure 10. Forward converter with snubber reset/clamp.

The snubber capacitor forms a quasi-resonant circuit with the transformer’s primary inductance, which can be used to control the rate of rise of the drain voltage, the peak drain voltage, and the reset period. For this reason, the capacitor must be chosen carefully as the reset-voltage waveform will impact the maximum allowable duty ratio and the peak MOSFET voltage. This single-switch reset scheme is usually limited to lower power applications of less than 100 W to avoid excessive dissipation in R_s .

A specialized version of this reset scheme is one in which the capacitor is made to fully resonate with the transformer’s primary inductance at about twice the switching frequency. This is sometimes called “resonant reset” and does not require the discharge resistor. This scheme is very effective but there is interplay between the reset times of both the core and the resonant capacitor. If not carefully implemented, problems can occur when approaching $D = 50\%$. Again, this design approach is typically limited to dc inputs of 100 W or less.

Single Switch with Active Clamp

The active-clamp topology is probably the best overall compromise in implementing the single-switch forward converter and is shown in Figure 11. This implementation requires the addition of another high-voltage, low-current MOSFET to actively switch the clamp capacitor in and out of the circuit during each switching cycle. It obviously requires a control chip with the active-clamp MOSFET drive synchronized with the main MOSFET gate drive, and driven from a floating driver or drive transformer.

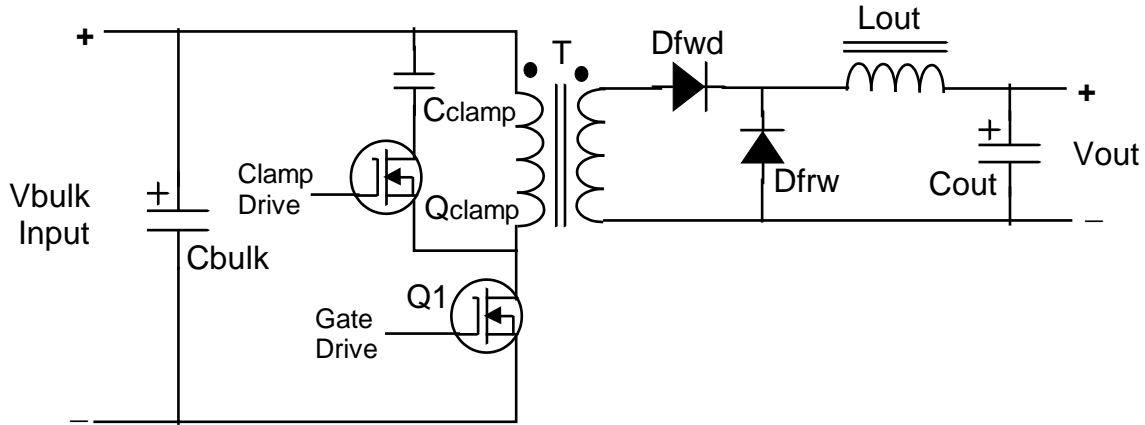

Figure 11. Active-clamp forward converter.

The active clamp is similar to the snubber reset circuit mentioned above, but is not dissipative and the reset energy is transferred back to the input bulk capacitor. It is a very efficient conversion scheme because proper tailoring of the clamp capacitor will result in quasi-resonant switching in the MOSFET and subsequently low switching losses and EMI generation. In addition, a duty ratio of over 50% is possible as long as an 800-V rated MOSFET is used for universal offline applications.

This is a very effective scheme for using synchronous secondary rectification for power levels up to around 500 W if overall conversion efficiency is the primary goal. The major drawback is the additional MOSFET, the necessary gate-drive circuitry, and the associated timing sequence that needs to be generated to control it. It should also be noted that the design of the transformer, particularly the primary and leakage inductance parameters, can be more critical since both of these parameters form a resonant circuit with the clamp capacitor. The transformer design typically needs to be gapped to lower the primary inductance to optimize the resonant turn-off waveform.

Nondissipative, Passive Clamp

An interesting "hybrid" configuration using features of the reset winding, the snubber, and active-clamp versions of the forward converter is shown in Figure 12. With a little circuit manipulation the clamp diode can be relocated to the other end of the reset winding and a snubber/clamp capacitor can be connected from the MOSFET Q1 drain back to the anode side of the reset-winding diode. In this configuration, the capacitor will absorb any leakage-inductance energy associated with the primary-to-reset winding and control the rate of rise of the voltage on the MOSFET such that switching losses at turn off can be minimized.

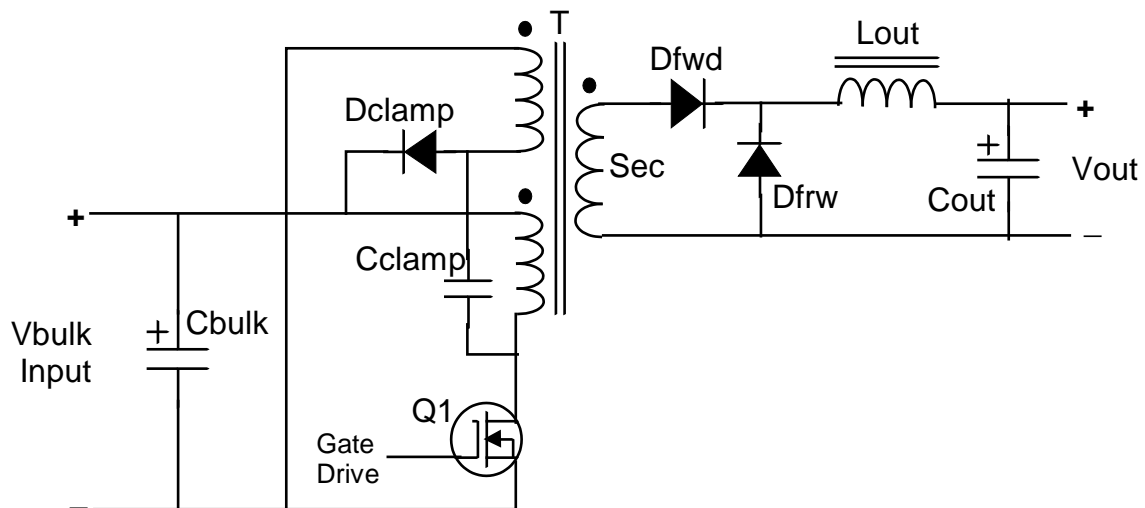

Figure 12. Passive clamp/snubber circuit.

Note that when the MOSFET is on, the capacitor is essentially discharged via the reset winding and stored energy is returned to the input bulk capacitor. What we have here is essentially a lossless snubber circuit. With larger values of Cclamp, the circuit can be made quasi-resonant (with the primary inductance) if necessary, to further improve switching losses and EMI characteristics. As with the original clamp winding configuration, the

duty ratio D is still limited to less than 50%. This passive clamp circuit is a favorite when simplicity, yet efficient performance is necessary.

Two-Switch Forward Converter

The two-switch forward converter shown in Figure 13 is definitely the most-popular forward implementation despite the added circuit complexity. This is because the MOSFET drain voltage is effectively clamped to V_{dc} input, and, consequently, lower-voltage MOSFETs can be used with much-lower on-state losses than is possible with 800-V (or greater) parts normally needed for offline single-switch forward converters.

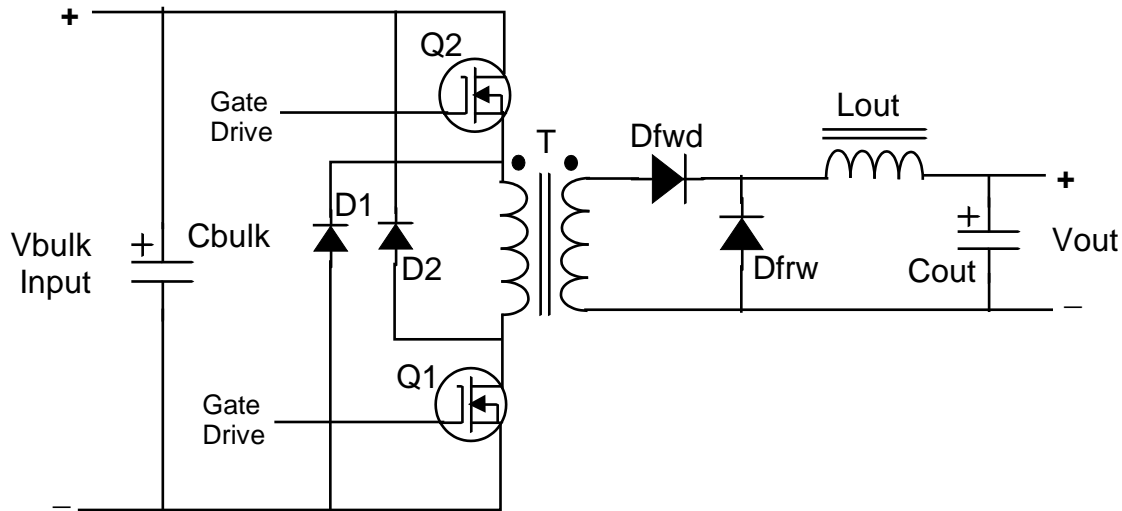

Figure 13. Two-switch forward converter.

By placing the switching MOSFET on each end of the transformer primary and cross coupling a pair of reset or commutating diodes back to the bulk-input bus, the maximum MOSFET drain voltage is constrained to V_{bulk} plus the two commutating-diode forward-voltage drops. Since the transformer primary is also used as the reset winding, there is no associated leakage inductance voltage spike as was the case with the single-switch forward with separate reset winding. The two-switch forward is also limited to less than 50% duty ratio due to the MOSFET drain voltages being clamped to V_{bulk} , thus requiring exactly the same core-reset time as the switch on-time.

Note that a floating gate driver or drive transformer is needed for the upper MOSFET in this circuit, which is switched in phase with the lower MOSFET. This particular forward-converter implementation is a very robust circuit and tends to be the industry “workhorse” for power levels up to a kilowatt and even more in some cases. A popular “mutation” of the two-switch forward is the so called “interleaved” version where two identical two-switch forwards are operated 180 degrees out of phase and their outputs are summed after the output chokes at a single output capacitor.

For improved efficiency, synchronous-rectification implementation of D_{fwd} is relatively easy, however, maintaining the freewheel diode in conduction for the entire off-period usually requires a current-sensing type of scheme for the D_{frw} synchronous MOSFET. Using the “self-driven” approach via the transformer secondary flyback voltage will only keep D_{frw} on as long as the flyback voltage persists, which will be the same as T_{on} . Once it disappears, the body diode of the MOSFET used for D_{frw} will conduct the freewheel current and conduction dissipation in this part will be quite high for the period it is on.

Forward Converter General Comments

All forward topologies will have poorer transformer core “utilization” because the core flux will operate in only one quadrant of the BH loop. As a consequence, a larger core will be required than that for a similar power-level half-bridge or full-bridge transformer, which have four-quadrant, bidirectional operation. Core losses, however, will be significantly less than a bidirectional topology since it is a function of B^2 .

Current-mode control is the desirable method for controlling the forward converter, however, the resonant reset and the active-clamp single-switch forwards could present problems due to a resonant “bump” on the leading edge of the MOSFET/primary-current waveform. If this bump amplitude exceeds the trailing-edge amplitude of the primary magnetizing current, a cycle-by-cycle peak detect type of current sensing will prematurely trip the

current-sensing circuit and terminate the half-cycle pulses, resulting in unstable operation. In such cases, voltage-mode operation is recommended.

There are forward-converter designs that will allow greater than 50% duty ratio operation as long as the transformer volt-second product is balanced. If current-mode control is used, keep in mind that slope compensation will be required for stability if D exceeds 50%.

The output choke for a forward converter will typically require more inductance than that of a similar bidirectional converter since it "sees" the converter switching frequency rather than double that frequency. The short on-time to off-time will also result in a higher-amplitude output-choke ripple current.

Bidirectional Converters

Bidirectional converters include the half bridge, full bridge (sometimes referred to as an "H" bridge), and the center-tap, push pull (CTPP). The CTPP will not be covered here since it is not widely used now except in special, low-voltage dc-dc converter applications. One of the primary advantages of the bidirectional converter is that transformer-core utilization is maximized because the flux swing is in all four quadrants and primary turns are minimized. As a consequence, they typically require the smallest core geometries for a given power level. The half- and full-bridge topologies are also voltage "clamped" topologies where the maximum voltage seen by the switching MOSFET drains is just the worst-case bulk V_{dc} .

One of the major drawbacks is the added complexity for the gate-drive to the MOSFETs. One or more paralleled MOSFETs are on the "high" or floating side of the transformer primary and require drive through either a small gate-drive transformer, or via a so-called "high-side" driver chip that allows for the switched, offset voltage required by the gates for the upper-side devices.

Perhaps one of the biggest drawbacks of the bidirectional converters from a reliability standpoint is the fact that a pair of series MOSFETs is connected directly across the bulk dc bus. If, for even a few nanoseconds, both devices are on simultaneously, catastrophic destruction will take place.

For this reason, the design of the gate-drive circuitry, the internal timing and noise immunity of the control chip, and the printed circuit layout of the areas associated with these components are critical. Short trace runs, low-inductance traces and minimal parasitic effects are imperative for the board layout. This is particularly true if high-side gate-driver chips are used, particularly at high frequencies. Such driver chips are not recommended for kilowatt applications where noise immunity can be compromised by high dI/dt and dV/dt waveforms in hard-switched implementations. When drive transformers are used, separate transformers should be used for each of the two different drive phases. Single drive transformers handling both phases will typically exhibit leakage inductance characteristics between opposite-phased secondary windings that can cause inadvertent and unwanted switch turn-on.

Half-Bridge Converter

The schematic of the basic half-bridge converter is shown in Figure 14. Note that the switching MOSFETs Q1 and Q2 alternately couple capacitors C1 and C2 across the primary of T1, respectively, and that the polarity is reversed each half-cycle providing the bidirectional, quasi-square wave drive. These capacitors form a voltage divider across the input bulk dc such that the switched primary voltage is half of the voltage on C_{bulk} . As a consequence, the peak current in the half-bridge primary winding is approximately the same as that of a forward converter operating at the same power level.

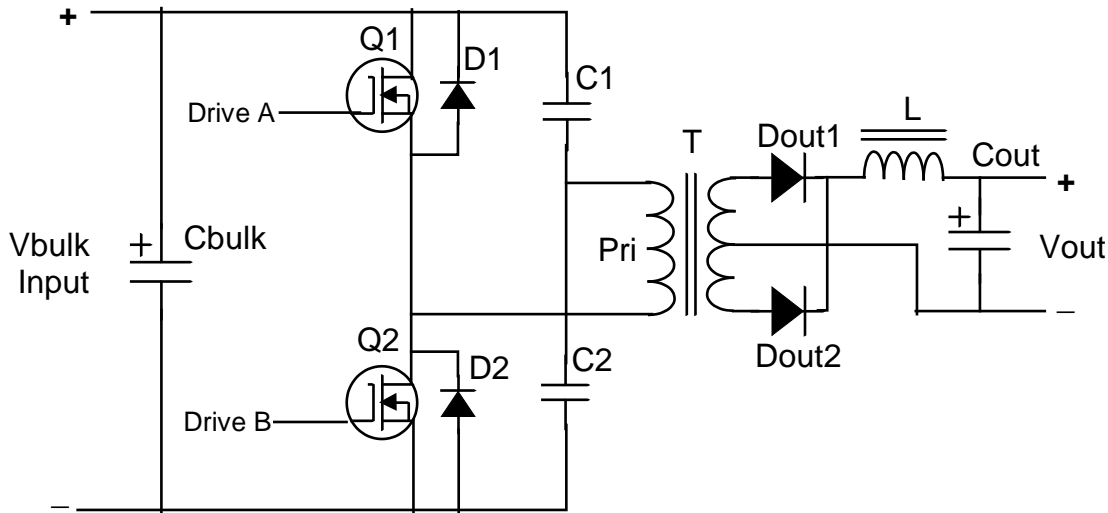

Figure 14. Half-bridge converter.

The real advantage comes in the bidirectional nature of the current and the lower switched-primary voltage such that the transformer core utilization is maximized. With operation in all four quadrants of the B-H loop, and half of the bulk voltage impressed on the winding, the primary turns will be minimal compared to the other topologies. This will allow for a very small and “dense” transformer construction for the half-bridge.

One caution with the half-bridge topology that is often overlooked: current-mode control with peak primary-current sensing cannot be used, and the control chip must be a voltage-mode-type controller. With peak-detect current-mode control, a runaway pulse-width condition ensues due to the fact that the primary is ac coupled through either C1 or C2. This creates an incompatible conflict condition between the primary volt-second product and the ampere-turns parameters for the primary circuit.

There have been several “band aid” circuits for this problem but they are generally not worth the added circuitry or expense. The crux of the problem is that the half-bridge primary is always ac coupled through a capacitor to the switching devices. There is another slight variation of the half-bridge topology where one primary coupling capacitor can be used instead of two. However, this configuration can cause unmanageable peak currents at circuit startup if the transformer is designed right to its flux density limits to minimize its size.

Another advantage of the half-bridge (or any bidirectional converter) is that the input-current ripple seen by the output choke L will be double the switching frequency of the inverter due to full-wave rectification, so the inductance and size of the output choke can be reduced over that of an equivalent-power forward converter. Half-bridge topologies can be used in just about any power level up to several kilowatts depending on the nature of the application’s size and cost restraints. Typical commercial uses are in the 500-W to 2-kW power range.

Since current-mode control is a very desirable feature but not useful here, the half-bridge can be very effectively used in what is called an LLC resonant mode for the medium-power ranges where compactness and efficiency are necessary and current-mode control is not required. This particular resonant implementation is extremely useful in applications where very high efficiency along with a low EMI signature is necessary.

Full-Bridge Converter

By replacing capacitors C1 and C2 with another pair of MOSFETs, the half-bridge can be converted into a “full” or “H” bridge where the full bulk voltage can now be alternately impressed across the primary with the proper gate-drive phasing. The full bridge is shown in Figure 15. With the full bulk voltage being switched across the transformer primary, double the amount of power is available from this configuration over the half-bridge for the same peak primary current. The transformer primary will, of course, have to be wound with more turns to accommodate the higher primary voltage, thus resulting in a somewhat larger core requirement than the half-bridge. In today’s newer MOSFETs, the intrinsic device body diode can be used in lieu of the external commutating diodes D1 through D4 as long as this internal diode has fast switching characteristics.

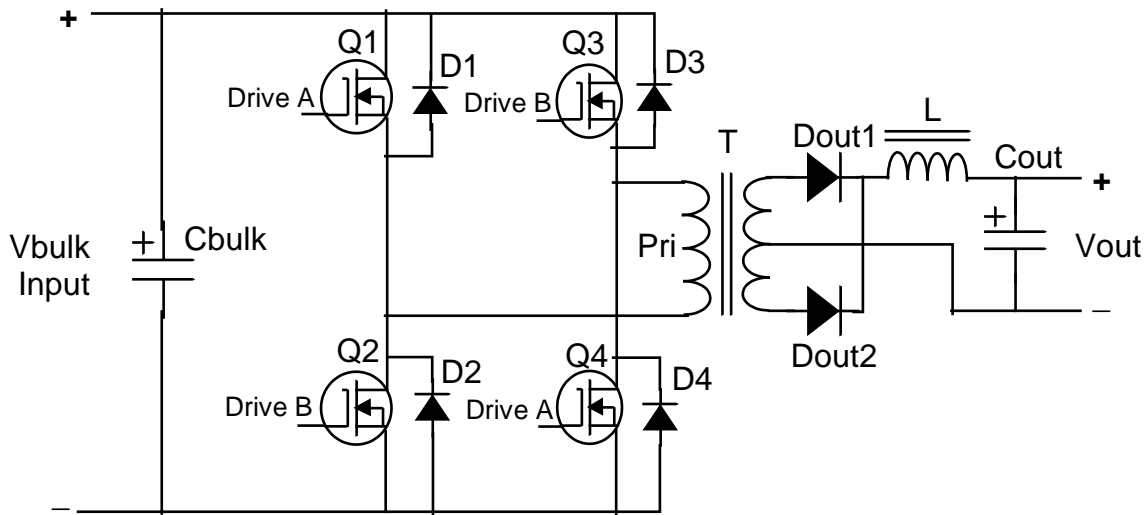

Figure 15. Full-bridge converter.

In the schematic configuration, current-mode control is applicable to the full bridge since the transformer primary is directly coupled to the switching bridge. In earlier bipolar transistor implementations where voltage-mode control was used, a polypropylene film capacitor similar to C1 or C2 in the half-bridge schematic was inserted in series with the primary to alleviate potential volt-second imbalances due to mismatched storage times in the bipolar devices. Adding this capacitor would obviously preclude the use of current-mode control for the same reasons it is not applicable in the half-bridge.

The full bridge is the ultimate high-power topology because all the parameters necessary to get the optimum power component utilization are brought together in this converter. The “price”, of course, is the more-complex gate drive necessary to handle all four banks of MOSFETs in the proper timing sequence. The typical power range is from a kilowatt to about 5 kW for “hard-switched” offline applications. If a phase-shifted or resonant version is used, the full-bridge is capable of power levels in the tens of kilowatts and even higher. The full-bridge topology is also useful in telecom applications of 48 V dc input where 500 W to several kilowatts of output power is necessary.

Bidirectional Converter General Comments

Since the above-mentioned bidirectional converters are buck derived, i.e. the secondary output is a buck L/C stage, the practical output-voltage level is typically limited to below 100 V dc due to output inductor size and control-loop feedback issues with high-inductance chokes. Transformer secondary winding capacitance can also be an issue with high output voltages. In such cases where high voltage at high power is required, the LLC resonant version of either the half- or full-bridge topology should be used where the output inductor is not needed (see section on resonant converters.)

One of the primary issues that can cause problems in high-power topologies is a lack of noise immunity in the control and drive circuitry. Care must be taken in both the printed circuit board layout and the design of the gate-drive technique. Liberal ground planes and careful attention to power and analog grounds is a necessity. This is absolutely paramount if semiconductor-based, high-side gate-drive circuits are used.

The vertical series connection of two MOSFETs directly across the bulk dc bus cannot be overlooked because with high dV/dt or dI/dt hard switching, the Miller capacitance of the MOSFET’s gate can be instrumental in causing a parasitic turn-on of one device when the other switches on. Subsequently, the effective impedance of the gate-drive circuit should look very low for the device that is supposed to be off.

Transformer core losses will always be higher in a bidirectional converter than in a unidirectional converter since the magnetic flux will transverse all four quadrants of the B-H loop and core losses are proportional to B^2 . It may be advantageous to design for less than maximum flux density or at least use the lowest-loss ferrite material for high-power designs.

Half-cycle transformer flux imbalance (B-H loop flux “walking”) used to be a major problem with the old bipolar switches. Although the lack of storage time in MOSFETs has helped that situation, one should still be aware of it. The use of current-mode control in the full-bridge and the use of voltage-mode control in the half-bridge

along with the ac (capacitive) coupled primary should negate any such half-cycle current imbalances that may be caused by circuit asymmetries in the transformer windings or the output rectifiers.

Resonant Topologies

Although any topology can be made resonant, the half- and full-bridge configurations are the ones that are typically made resonant for high-power and/or high-efficiency applications where switching losses need to be minimized. In such implementations, phase-shifting gate-drive circuitry or additional capacitances and inductances are added to the PWM converter to force either the switched-current or voltage waveforms to be less steep (quasi-resonance) such that zero-voltage switching (ZVS) or zero-current switching (ZCS) can occur. Nonresonant "hard switching" results in simultaneous voltage and current appearing on the MOSFETs momentarily during the switching transitions with the result of high switching losses, particularly in high-frequency implementations.

The bidirectional converters can also be made fully resonant for even higher efficiency and lower EMI signatures. In this case, frequency or pulse-rate modulation (PRM) is required to control the overall duty ratio since the resonant period must be kept constant. Figure 16 shows a resonant half-bridge generally referred to as an LLC half-bridge. In the resonant configuration, the transformer's primary leakage inductance is made to resonate with the parallel capacitance of bulk divider capacitors C1 and C2. By varying the frequency of the converter the resonant L/C circuit can be made to function as a variable impedance, thus controlling the output voltage and/or current via the frequency.

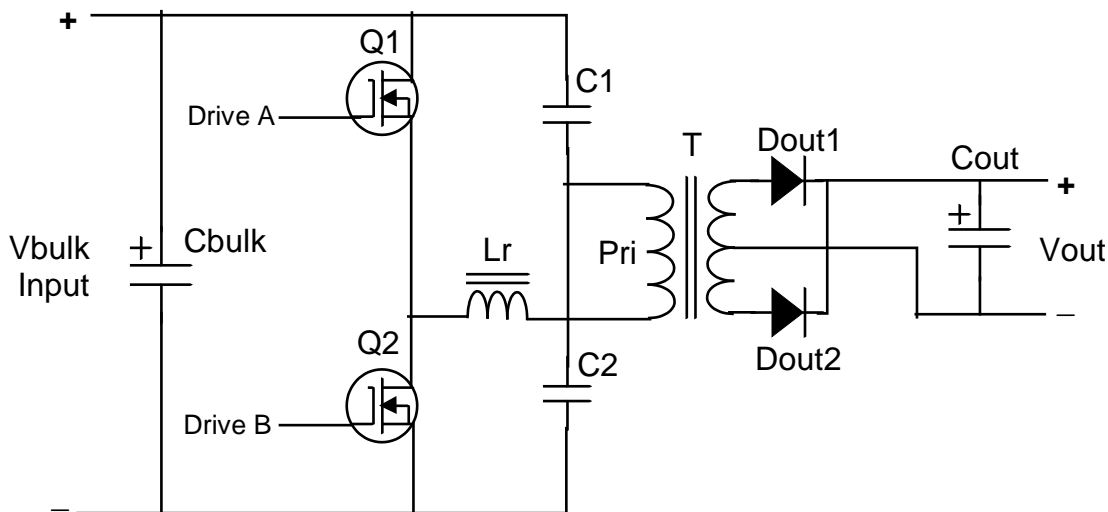

Figure 16. LLC resonant half bridge.

In cases where the transformer leakage-inductance value cannot be made exactly the desired resonant value, a series "shim" inductance (L_r) is added to make up the difference. By using this series-resonant configuration, the converter output characteristic is that of a current source, so an output choke typical of the buck-derived secondary is not necessary. This topology is particularly efficient due to its zero current and zero voltage switching characteristics and is also ideal for high output-voltage applications.

The design of the transformer for this converter is not a trivial task, particularly if the transformer leakage inductance is to be the complete resonant inductor element. Since leakage inductance is a function of core winding geometry and primary turns, it can be difficult to find a particular combination that satisfies all the necessary transformer electrical parameters without adding an additional shim inductance.

The active-clamp forward converter is actually a quasi-resonant (QR) implementation since the clamp capacitor is made to resonate with the transformer's primary magnetizing inductance. The passive clamp version can also be made quasi-resonant (QR) depending on the selection of the clamp capacitor and the primary inductance of the transformer. There are QR versions of the two-switch forward, however, these are rare and are typically protected by patents at this time.

The most cost-effective and useful QR implementation of the flyback is the CRM version with valley switching that was mentioned in the flyback part of this article. The low MOSFET switching losses coupled with the easy

ability to implement synchronous output rectification makes this configuration hard to beat for simplicity and high efficiency.

There are numerous techniques to make just about any topology either quasi-resonant or fully resonant for the purposes of improved efficiency at higher switching frequencies where packaging density is imperative. As with most areas of electronics there is always a potential performance, cost and/or circuit complexity trade-off.

Additional Reading

Rudy Severns and Gordon Bloom, "Modern DC-to-DC Switchmode Power Converter Circuits, Van Nostrand Reinhold, 1985, ISBN 0-442-21396-4

Keith Billings, "Switchmode Power Supply Handbook," McGraw-Hill, 1989, ISBN 0-07-0053330-8

Ralph Tarter, "Solid-State Power Conversion Handbook," John Wiley & Sons, 1993, ISBN 0-471-57243-8

Christophe Basso, "Switch-Mode Power Supply Spice Cookbook," McGraw-Hill, 2001, ISBN 0-07-137646-1

Christophe Basso, "Switch-Mode Power Supplies," McGraw-Hill, 2008, ISBN 978-0-07-159769-2

ON Semiconductor Application Notes: AND8069, AND8089, AND8112, AND8127, AND8161, AND8252, AND8255, AND8293, AND8311, and AND8397.

ON Semiconductor Reference Designs: TND313, TND316, TND330, and TND359.

About the Author



Frank Cathell has been a senior applications engineer with ON Semiconductor for over 6 years. Frank has worked in the power electronics industry for over 35 years and has obtained several patents for power conversion circuits and has written numerous articles and/or papers on the subject. Frank's previous employment has included Lambda Electronics, International Power Systems, Maxwell Laboratories, Tectrol Inc. and others in addition to his own past consulting business.

For further reading on power supply topologies, see the [How2Power Design Guide](#) and search the Topology category. Also, for examples of charts comparing different power supply topologies (like those referred to at the beginning of Frank Cathell's article), see the [Power Around the Web](#) page, where you'll find descriptions of such charts and links to them under "Charts & References (Power Electronics)."