

# Secondary-Side Bridge Rectification for Wireless Charging Applications

Efficiency considerations are critical for wireless charging solutions.

By Ann Starks, Applications Engineer, Power MOSFET Division, ON Semiconductor

In today's industry there is a continual need for on-the-go power management, and wireless (contactless) charging solutions are becoming more and more prevalent in the marketplace. While not as efficient as existing wired solutions, wireless charging provides increased convenience to the consumer and eliminates the need for additional charging cables. Wireless charging has applications in the portable electronics industry, the auto industry, and even the medical industry.

In today's high tech society, there is an increasing desire for convenient charging solutions for multiple electrical devices. Potential wireless charging market opportunities include use in vehicles, airports, and inside the home. Gaming platforms now offer wireless charging options for their controllers with the goal of added convenience to the consumer. As wireless charging gains popularity, many cell phone manufacturers have begun offering battery covers that incorporate additional circuitry to make their products compatible with wireless charging.

Wireless charging is not a new concept. For years, electronic toothbrushes and razors have utilized this charging method. The consumer simply places the device into the base unit to charge the battery, without the need for exposed metal contacts. Wireless charging reduces or eliminates the need for charging cables, and can provide the ability to charge multiple devices at

once by simply placing them on a charging pad.

Wireless charging is accomplished by use of an air-core transformer. The primary winding is located in the charging pad and the secondary winding is located within the device itself. The charging pad induces a current in the secondary winding that passes through a full-bridge rectifier and additional circuitry within the hand-held device to create a DC voltage that charges the battery. Figure 1 shows an example block diagram of a wireless charging circuit. The base unit is powered from a standard wall outlet. Once the hand-held device is placed on the base unit, the battery begins to charge.

## Transformer Basics

When current passes through a coil of wire, a magnetic field is produced. The transformer uses this fundamental property to induce a current from one winding to another. The turns ratio,  $N$ , is the ratio of number of turns in the secondary winding to the number of turns in the primary winding.

$$N = \frac{n_s}{n_p}$$

The turns ratio is used to calculate the voltage and current induced in the secondary winding. The voltage produced in the secondary winding can be calculated as:

$$V_s = V_p * N$$

The current in the secondary winding is calculated as:

$$I_s = \frac{I_p}{N}$$

Transformers can be designed in various configurations and use a core material to induce the magnetic field in the secondary winding. Permeability,  $\mu$ , is a measure of how effectively a magnetic field is created within the transformer. In other words, how efficiently the transformer delivers power to the secondary winding. The higher the permeability, the more effective the transformer is at transferring power from the primary to the secondary. Intrinsic permeability is the permeability of free space in a vacuum, and is defined as:

$$\mu_0 = 4\pi * 10^{-7} \text{N/A}^2$$

Units are in Newtons per Ampere-squared. The relative permeability is defined as the permeability of a specific material

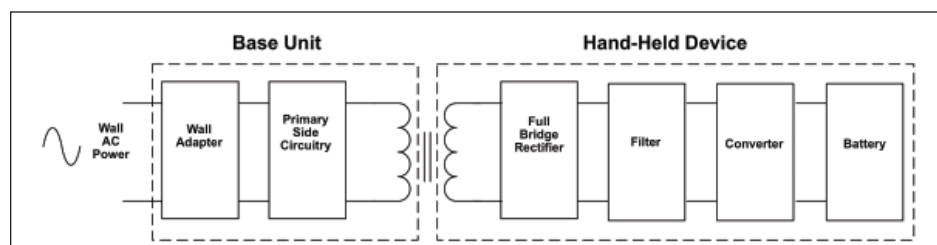

Figure 1 (above): Wireless Charging Example Diagram

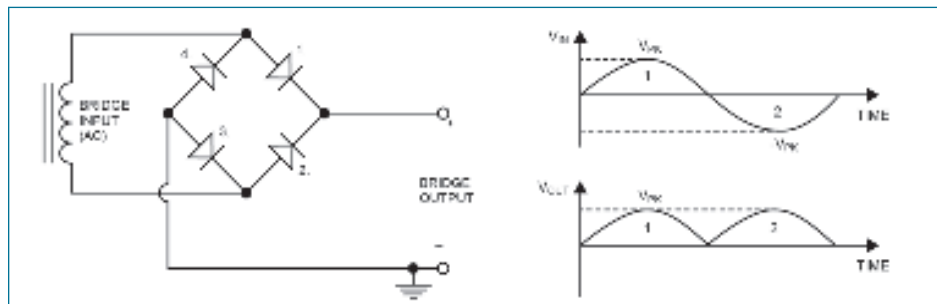

Figure 2 (above): Full Bridge Rectifier: 4 Diode Configuration

divided by the intrinsic permeability, or:

$$\text{Relative Permeability} = \frac{\mu}{\mu_0}$$

A very popular material used in today's industry is the Ferrite core. The relative permeability of a manganese zinc ferrite core is 640 or greater. For wireless chargers, however, air is the core material. This is because the primary winding is located in a separate unit from the secondary winding. The relative permeability of air is 1, resulting in a much less efficient transformer. Because the transformer efficiency is low, the efficiency of the rest of the circuit becomes very important.

### Secondary Side Bridge Rectification

The full-bridge rectifier and filter circuit produces a constant DC voltage from the AC signal induced in the secondary winding. Figure 2 shows a full-bridge rectifier circuit using a four-diode configuration.

When diodes 1 and 3 are forward-biased, diodes 2 and 4 are reverse-biased, and vice versa. Therefore, the main power loss across the bridge is the forward drop across the two diodes. A standard diode has a voltage drop of approximately 0.7 V. This means that the power loss across the two diodes is:

$$P_{\text{loss}} = I_{\text{Load}} * (V_{F1} + V_{F2}) = I_{\text{Load}} * 2^{(0.7V)}$$

A Schottky diode has a much lower forward voltage drop, typically around 0.4 V. For the bridge configuration shown in Figure 2, the Schottky diodes give better efficiency. The example input waveform shown in Figure 2 is a sine wave with amplitude VPK. The rectified output has an amplitude of VPK and both halves of the cycle are positive.

Figure 3 shows the current path across the bridge and load for Region 1 and Region 2 of the input voltage sine wave. During the first half of the input voltage cycle (Region 1 and Figure 4a) the voltage at node a is higher than the voltage at node b. Current flows through diode 1, across the load, and returns to the transformer through diode 3. During the second half of the input voltage cycle (Region 2 and Figure 4b) the voltage at node b is higher than the voltage at node a, and current flows in the opposite direction through diode 2, across the load, and returns to the transformer through diode 4. In each case, current flows in the same direction across the load itself, producing the output voltage waveform seen in Figure 2.

VIEW THIS ARTICLE ONLINE!  
» GO TO:  
<http://bit.ly/wdd-tech>

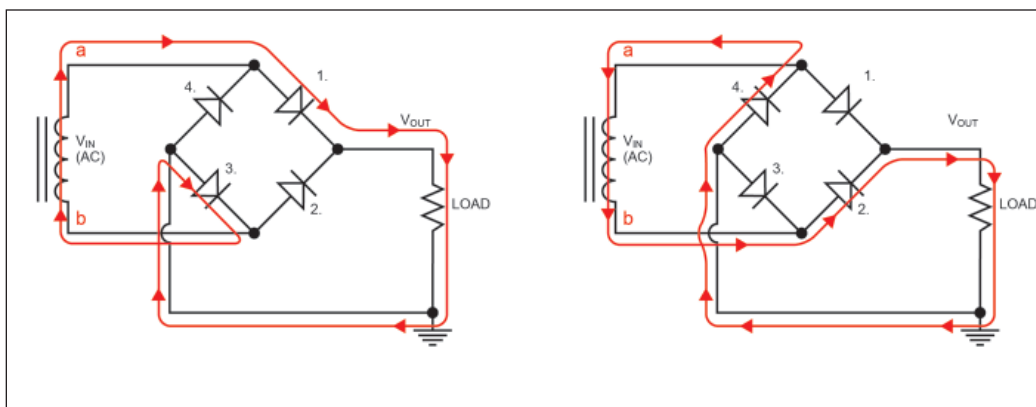

Figure 3: Current Path During (a) Region 1 and (b) Region 2 of the Input Waveform.

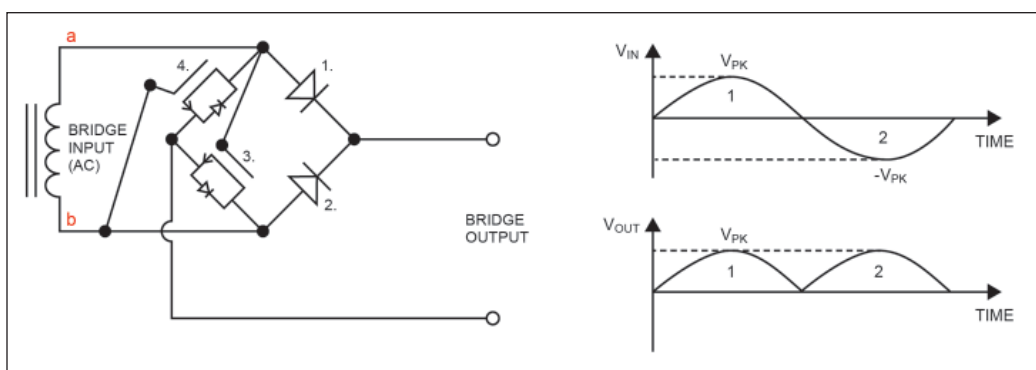

Figure 4: Full Bridge Rectifier: 2 Diode, 2 MOSFET Configuration

A second full bridge rectifier configuration consists of two diodes and two MOSFET devices. Figure 4 shows an example of this configuration.

For this bridge configuration, diodes 3 and 4 are replaced with N-channel MOSFETs. The gate of MOSFET 3 is tied to node a and the gate of MOSFET 4 is connected to node b. The body diode of each MOSFET blocks current flow when that MOSFET is off. The example bridge input and output waveforms are the same as the previous bridge configuration. During Region 1, the voltage at node a is higher than the voltage at node b. Diode 1 is forward-biased, Diode 2 is reverse-biased, MOSFET 3 is on and MOSFET 4 is off (with the body diode of MOSFET 4 reverse-biased). During Region 2, the voltage at node b is higher than the voltage at node a. Diode 2 is forward-biased, Diode 1 is reverse-biased, MOSFET 4 is on and MOSFET 3 is off (with the body diode of MOSFET 3 reverse-biased).

The current path and resulting output waveform is the same as the previous configuration. However, by replacing two diodes with MOSFETs, the bridge effi-

ciency is increased, and the power loss across the diode and MOSFET becomes:

$$P_{\text{loss}} = I_{\text{Load}} * V_{F1} + I_{\text{Load}}^2 * R_{\text{DS(ON)}}$$

The third implementation results in the lowest power loss. This power loss savings translates directly into improved efficiency of the secondary circuit as a whole, making the wireless charging solution more energy efficient.

Efficiency considerations are critical for wireless charging solutions, due to the lower efficiency nature of the air-gap transformer over traditional wired solutions. Therefore, to maximize the performance for wireless charging, the efficiency of each circuit block must be carefully considered and addressed. Implementing a two-diode and two-MOSFET solution results in a large power loss savings. For the electronics industry today, energy conservation and improved efficiency are at the forefront of the minds of both consumer and manufacturers. As wireless charging gains momentum, so too does the increased need for high-efficiency and high performance solutions. **WDD**