



Is Now Part of



ON Semiconductor®

To learn more about ON Semiconductor, please visit our website at
www.onsemi.com

ON Semiconductor and the ON Semiconductor logo are trademarks of Semiconductor Components Industries, LLC dba ON Semiconductor or its subsidiaries in the United States and/or other countries. ON Semiconductor owns the rights to a number of patents, trademarks, copyrights, trade secrets, and other intellectual property. A listing of ON Semiconductor's product/patent coverage may be accessed at www.onsemi.com/site/pdf/Patent-Marking.pdf. ON Semiconductor reserves the right to make changes without further notice to any products herein. ON Semiconductor makes no warranty, representation or guarantee regarding the suitability of its products for any particular purpose, nor does ON Semiconductor assume any liability arising out of the application or use of any product or circuit, and specifically disclaims any and all liability, including without limitation special, consequential or incidental damages. Buyer is responsible for its products and applications using ON Semiconductor products, including compliance with all laws, regulations and safety requirements or standards, regardless of any support or applications information provided by ON Semiconductor. "Typical" parameters which may be provided in ON Semiconductor data sheets and/or specifications can and do vary in different applications and actual performance may vary over time. All operating parameters, including "Typicals" must be validated for each customer application by customer's technical experts. ON Semiconductor does not convey any license under its patent rights nor the rights of others. ON Semiconductor products are not designed, intended, or authorized for use as a critical component in life support systems or any FDA Class 3 medical devices or medical devices with a same or similar classification in a foreign jurisdiction or any devices intended for implantation in the human body. Should Buyer purchase or use ON Semiconductor products for any such unintended or unauthorized application, Buyer shall indemnify and hold ON Semiconductor and its officers, employees, subsidiaries, affiliates, and distributors harmless against all claims, costs, damages, and expenses, and reasonable attorney fees arising out of, directly or indirectly, any claim of personal injury or death associated with such unintended or unauthorized use, even if such claim alleges that ON Semiconductor was negligent regarding the design or manufacture of the part. ON Semiconductor is an Equal Opportunity/Affirmative Action Employer. This literature is subject to all applicable copyright laws and is not for resale in any manner.

Application Note AN-3007

MID400 Power Line Monitor

Introduction

The MID400 is an optically isolated AC line-to-logic interface device for monitoring ON or OFF status of an AC power line. The logic circuitry operates from a standard 5V supply. The MID400 is packaged in a compact 8-pin plastic DIP. The optical isolation provided by the MID400 makes it suitable for power-to-logic interface applications such as industrial controls medical equipment, computers and other fail-safe type monitor systems in which status information about the AC line is essential.

Internal Components

During assembly two infrared GaAs LED diodes are mounted on an input lead frame, and a photodetector/amplifier chip is mounted on an output frame. Use of two separate lead frames insures high electrical isolation between input and output terminals after trimming of the lead frame edges. Light emitted by the input LED's is optically coupled through a transparent material to the surface of the photodetector. The LED's are connected back-to-back, and power line status is monitored by the LED's in series with an external current limiting resistor. When the high gain photodetector and amplifier senses light output from the two LED's, it drives an output NPN transistor to the ON state.

The photodetector amplifier circuit is shown in Figure 1. The Photodiode, D3, is coupled into a high gain 3 stage emitter follower current amplifier ($Q_1Q_3Q_5$) driving into an output

transistor Q_8 . The emitter follower loads are comprised of constant current circuits formed by $Q_2, R_2, Q_4, R_3, Q_6,$ and R_4 . Constant current level in these devices is established by the constant voltage source formed by the base emitter voltage of Q_7 and R_5 .

The common point of the output photodiode/amplifier is brought out to pin 7 to allow connection of an external integrator capacitor or other circuits. Because the amplifier has a high current gain factor of 10,000 to 100,000, its input impedance (at pin 7) is extremely high.

Switching time of the amplifier is intentionally designed to be slow, so that the MID400 only responds to an absence of input signal over a few milliseconds, and not during the short zero-crossing period of the AC input voltage waveform.

Basic Circuit Operation

Consider the test circuit shown in Figure 2. Back-to-back input diodes D_1 and D_2 each conduct on every half cycle of the AC input waveform, producing 120Hz light pulses. The light output causes the photodiode to conduct, raising the potential of the input to the amplifier, and in turn driving the output NPN transistor ON. When input current is removed, light from the two LED's ceases, charge established by the photodiode current on the input amplifier leaks away, and the NPN transistor turns OFF. There are basically three operation modes: Saturated, unsaturated, and the "OFF" STATE mode.

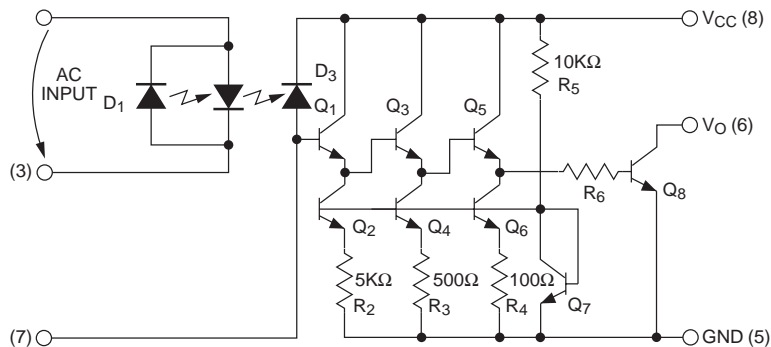

Figure 1. Circuit Schematic of MID400 AC Line Monitor

Saturated Mode

When input AC is above the recommended 4mA RMS minimum input current, the 120Hz photodiode pulses are sufficient to saturate the amplifier, so that the MID400 output is low at pin 6 as long as the AC input signal is present, (see Figure 3).

Unsaturated Mode

If input current is dropped below the recommended 4mA RMS minimum input current, the amplifier drops out of saturation during the zero-crossing periods of the input AC waveform and 120Hz pulses appear on the MID400 output pin 6, (see Figure 4). Under these conditions the device makes an attractive, simple 120Hz clock generator that is free from most of the normal power line transients for many digital applications.

Off-State Mode

When the input RMS AC input current is below 0.15mA the MID400 output will be in the high state as per specifications.

Operation with an External Capacitor

Figure 5 shows a basic delay circuit obtained by addition of an integrating capacitor C_X to the photodiode/amplifier input point pin 7. Delay at POWER ON is short, as the photodiode, when conducting, has a low impedance providing a fast charge to the capacitor. The delay when AC is removed is long, because the capacitor discharges through various leak-ages of the amplifier and the photodiode. The waveforms in Figure 6 shows the capacitance on both TURN-ON and TURN-OFF delays. Figures 7 and 8 show plots of capacitance versus turn-on and turn-off time.

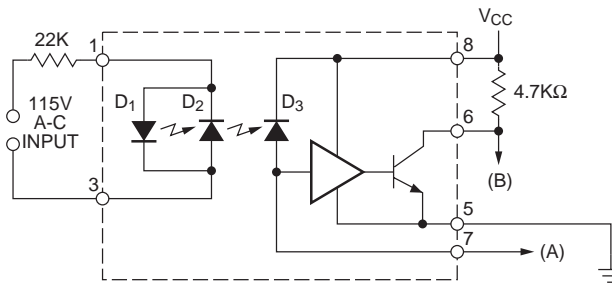

Figure 2. Test Circuit

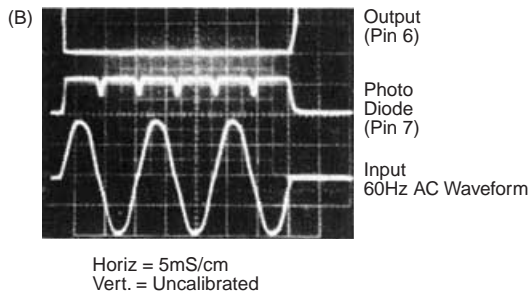

Figure 3. Saturated Operation

NOTE: Normal specified 4mA RMS input current. Output saturated (latched). The 120Hz pulses from the photodiode D_3 are above the threshold of the amplifier; therefore, the MID400 output is low anytime the AC current is present.

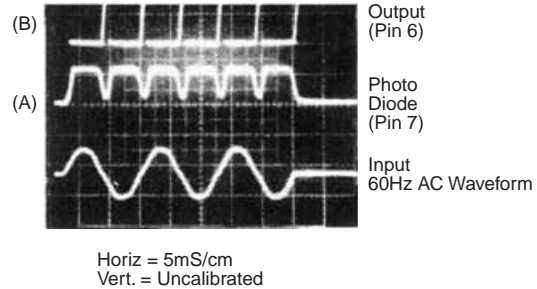

Figure 4. Unsaturated Operation

NOTE: Below normal specified 4mA RMS input current. The level of 120Hz pulses from the photodiode are now below the input threshold of the amplifier and the pulses appear on the output. The output pulse width depends on the AC input drive level.

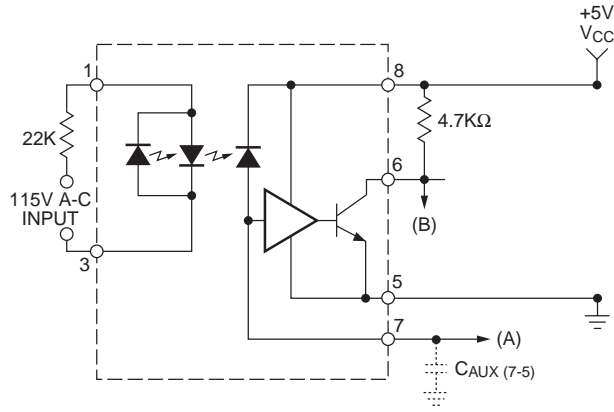

Figure 5. Circuit with Addition of Capacitor at Pin 7

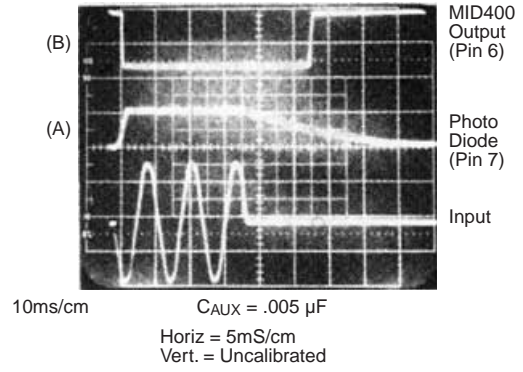

Figure 6. Waveforms with Capacitor Added at Pin 7

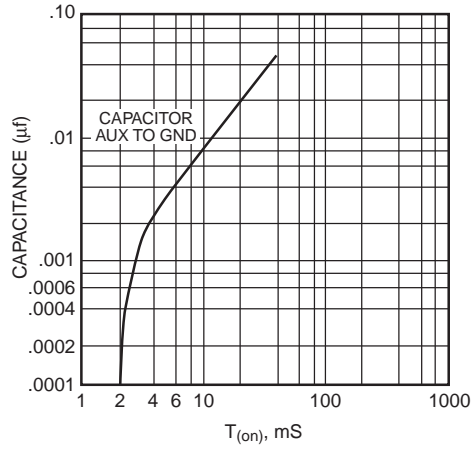

Figure 7. Plot of Capacitance Versus Turn-on Time

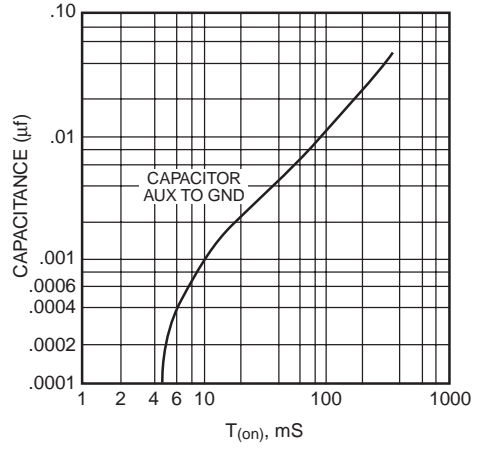

Figure 8. Plot of Capacitance Versus Turn-off Time

MID400 Interface Circuits using a 555 Timer

Addition of a 555 Timer at the MID400 output, as shown in Figure 9, produces an interface circuit with improved drive capability and output switching times, and better noise immunity. Figure 10 illustrates these switching time improvements.

The 555 Timer is basically being used as a SCHMITT trigger circuit with well defined input thresholds. The input HIGH state is $2/3 V_{CC}$, +5 volts in this case), and its LOW state is $1/3 V_{CC}$.

The output may be taken from either 555 pin 3 or from pin 7 discharge point with a pullup resistor. Both these Pins are high when AC current is applied to the MID400.

The 555 output is capable of supplying both sink and source currents up to 200mA. One advantage of using the 555 discharge output pin is that it can be tied to another similar unit to provide the "AND" function. That is both AC inputs to both units must be present before the 555 outputs can be high.

Figure 11 shows a circuit which includes a 555 Timer for shaping of waveforms. This circuit can provide an adjustable delay either at power on or power off. Delay is adjusted by the time constant of R_x and C_x . Insertion of diode D_1 , across R_x provides either a fast charge and slow discharge of C_x , or a slow charge and fast discharge when diode polarity is reversed. See waveforms in Figures 12 through 14. Because charge on the capacitor is established by the output of the MID400, the delay will vary according to whether the MID400 is operated in saturated mode or unsaturated mode. In the unsaturated mode delay will depend upon the ratio of the pulse ON to OFF time (Duty Factor).

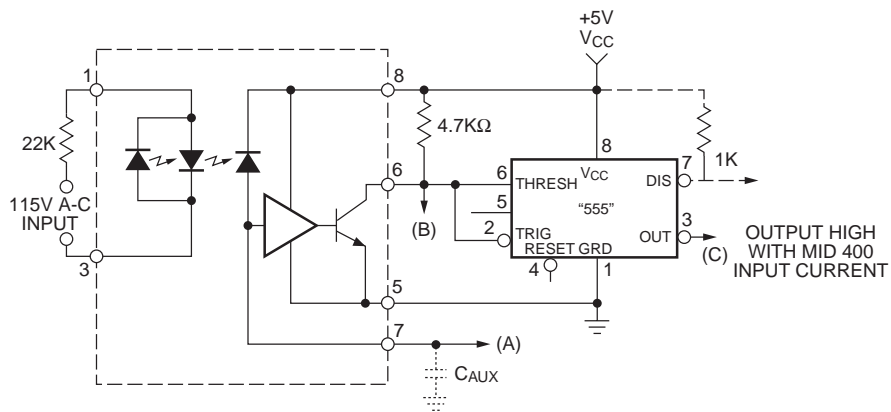

Figure 9. Circuit with 555 Timer Added

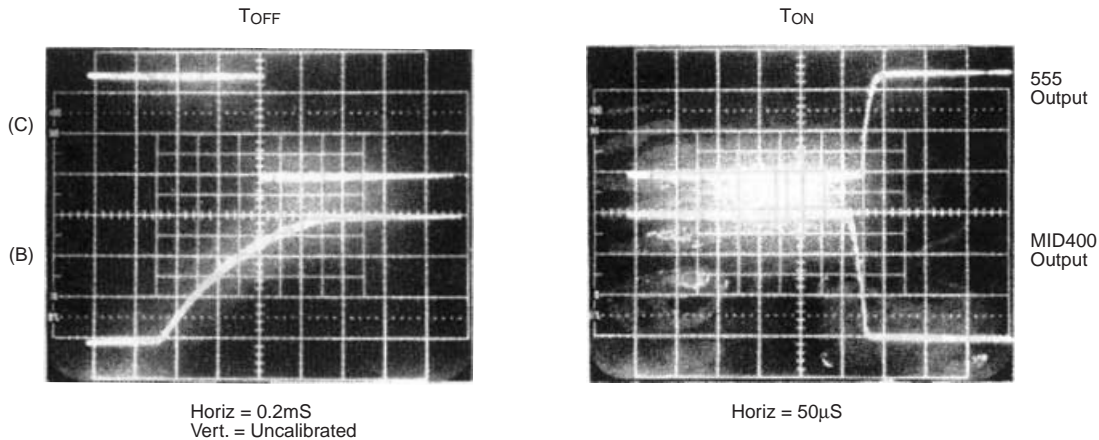

Figure 10. Output Waveforms for T_{ON} , T_{OFF} . Pin 7 Auxiliary Input Open Using the 555 Circuit (Fig. 9)

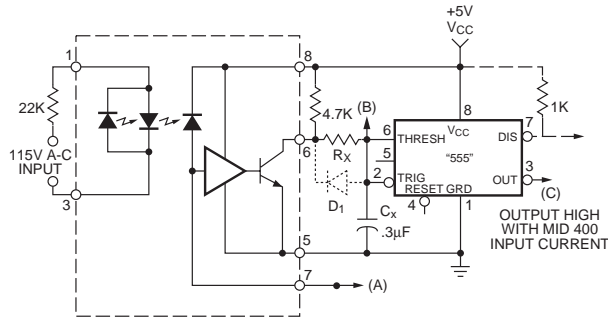
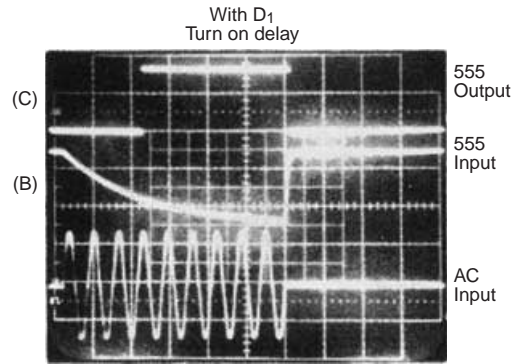
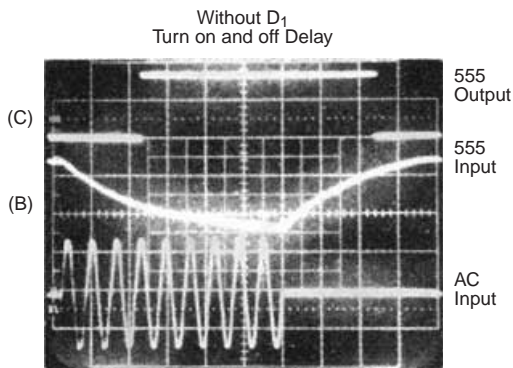

Figure 11. Adjustable Delay Turn Off/On Circuit



Horiz = 20mS/cm
 Vert. = Uncalibrated
 $R_X = 200K\Omega$
 $C_X = 0.3\mu F$

Figure 13. Delay Turn On, D_1 Diode Connected In Reverse Polarity to That Shown in Circuit Schematic



Horiz = 20mS/cm
 Vert. = Uncalibrated
 $R_X = 200K\Omega$
 $C_X = 0.3\mu F$

Figure 12. Output Without D_1 Diode

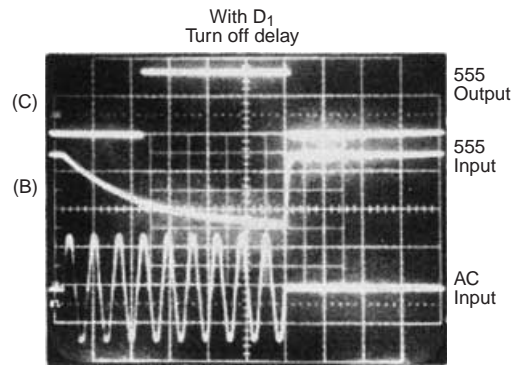

Horiz = 20mS/cm
 Vert. = Uncalibrated
 $R_X = 200K\Omega$
 $C_X = 0.3\mu F$

Figure 14. Delay Turn Off, D_1 Diode Connected as Shown in Circuit Schematic

Figure 15 shows a precision delay circuit. Here delay is provided by using the 555 Timer as a missing pulse detector or one-shot. The time out is independent of whether the MID400 is operated in saturated or unsaturated mode. In unsaturated mode the Timer is continuously being reset by the 120Hz pulses from the MID400 and output of the 555 is high. When an AC line fails, there are no 120 Hz pulses, the 555 times out and the output then goes low. Refer to waveforms in Figure 16.

A larger capacitor at C_x will increase the time-out period of the 555 causing it not to detect the missing input cycles as shown in Figure 17.

With the MID400 operated in the saturated mode, the output of the MID400 is low, which turns on the PNP transistor Q_1 , stopping C_x from charging, and the 555 output is high.

On AC line failure the MID400 goes high, causing Q_1 to turn off and allowing C_x to charge, so that after the required time the 555 is allowed to go LOW. Refer to the waveform in Figure 18.

By the choice of the time constant $R_x C_x$ the circuit in either a saturated or unsaturated mode can be made to either respond or not respond to one or more AC input cycles as shown in Figures 16 through 19.

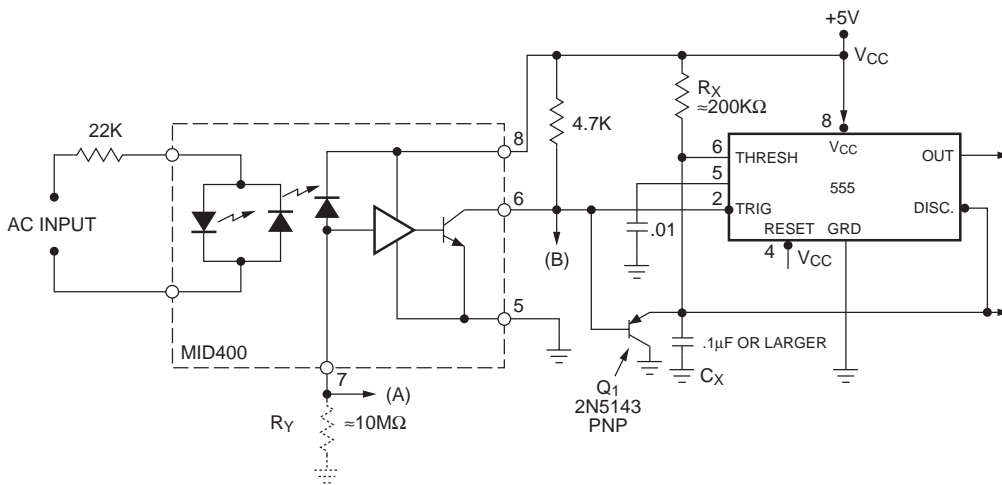

Figure 15. Precision Delay Circuit

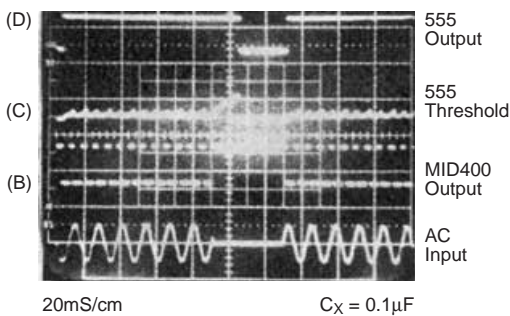

Figure 16. Unsaturated Mode – Detects Missing AC Input Cycles (when more than one cycle is missing)

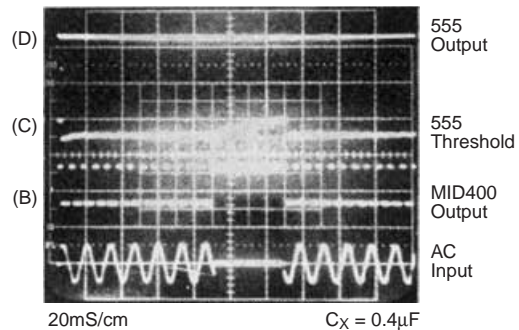

Figure 17. Unsaturated Mode – Does NOT Detect Missing AC Input Cycles

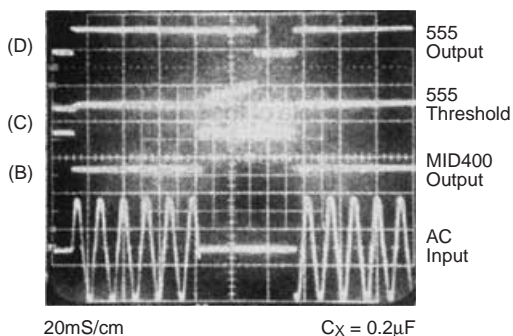

Figure 18. Saturated Mode – Detects Missing AC Input Cycles

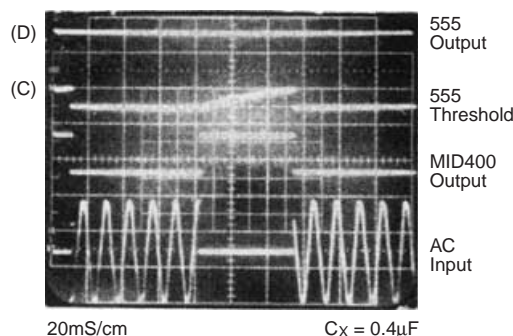

Figure 19. Saturated Mode – Does NOT Detect Missing AC Input Cycles

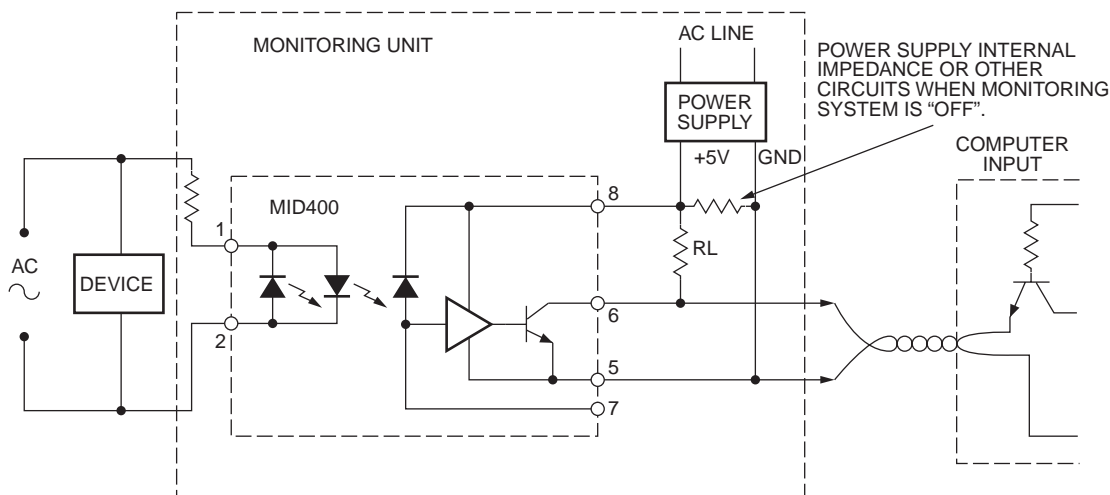

Figure 20. Example For Fail Safe Considerations

Other Special Design Considerations

Special mention must be made about effects on MID400 operation caused by leakage at pin 7. To avoid problems keep the impedance at 10 megohm or greater. If a capacitor is connected to pin 7, make sure it is a high quality type (such as Mylar) that exhibits very low leakage. (Even current leakage between printed circuit traces can have noticeable effects on circuit operation if the board material has poor dielectric insulation characteristics.)

Designs for Fail-Safe Operation

In those industrial, military, computer, and medical system applications where fail-safe operation is important, circuit response must also be considered when the AC input or the V_{CC} supply, (or even both), switch off.

Table 1 lists the MID400 output response under these conditions. This “Truth Table” shows that the MID400 output NPN transistor can be ON (conducting) only when AC current is flowing through MID400 input LED diodes **and** the 5V V_{CC} to the MID400 is present (ON).

Table 1. Fail-Safe Truth Table

AC Line Input	+5 V_{CC} Supply	MID400 Output Condition
ON	ON	ON (conducting)
ON	OFF	OPEN (non-conducting)
OFF	ON	OPEN (non-conducting)
OFF	OFF	OPEN (non-conducting)

This truth table reflects a MID400 being operated from a +5 volt supply which has a high impedance when not “ON.” However, other external factors can influence the apparent state of the MID400 output. For example, Figure 20 shows an application where the MID400 is monitoring the AC voltage of a device. The MID400 is supplied by a separate 5V supply in the “MONITOR UNIT” fed from a separate AC line. The output of MID400 is fed to a remote computer with a TTL type input circuit.

In this system it is quite feasible to get an erroneous apparent output from the MID400 if R_L is 1000 ohms, or less, and the 5V power supply in the monitor system presents a low impedance when OFF. The TTL input to the computer might appear low due to current being forced through R_L and the low impedance of the OFF 5V power supply. This can be eliminated by the addition of a diode D_x as shown in Figure 21.

In some applications additional circuitry may have to be added to insure fail-safe operation. One such example is the monitor circuit shown later, Figure 24. There, both voltage and current are monitored.

Another interesting condition to consider is operation of the MID400 if its LED input diodes are "blown out" by excessive current. In this case the MID400 output will be in the high state, still indicating an error condition.

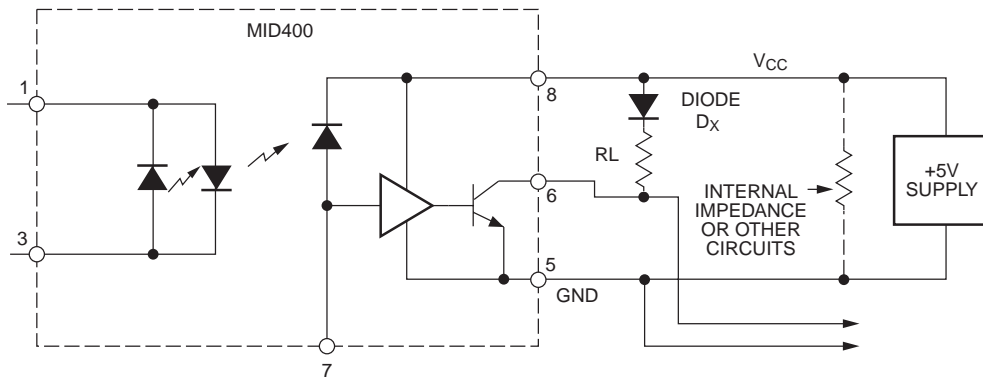

Figure 21. Diode D_x Added to Stop Reverse Current When MID400 + 5V V_{CC} Line is Off

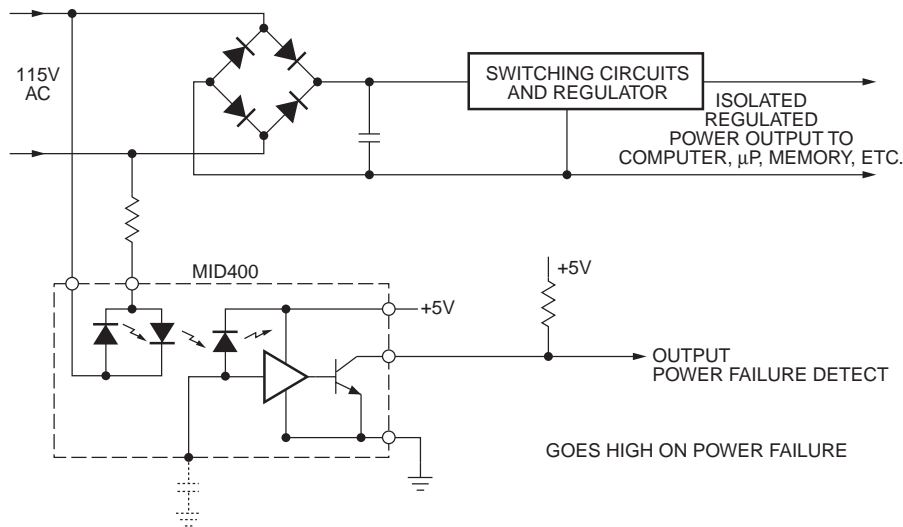

Figure 22. Circuit for Switching Power Supply

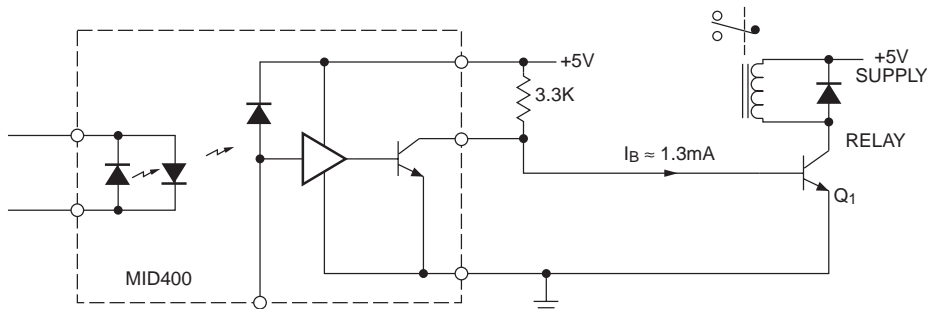

Figure 23. Relay Interface Circuit

Application Circuits

Figure 22 shows a circuit for a switching power supply to give advanced warning of power failure to computer, micro-processor, memory etc., so that an orderly power down sequence can be initiated. Such a circuit is useful because a switching power supply inherently provides power storage for a limited period of time after removal of AC input power.

Figure 23 shows a circuit that allows a relay or solenoid of almost any voltage and current rating to be controlled by the MID400. NPN transistor Q_1 must have adequate beta and voltage/current ratings for the application. The relay is energized when no AC current is flowing in the MID400 input diodes.

Figure 24 shows a circuit that uses two MID400s to monitor both voltage and current. When both voltage and current are

being supplied to the load, the output of the “NOR” gate is high. If the load current drops due to either an open circuit or failure, the output of the “NOR” gate is low.

If both voltage and current are not present the output is low. Care must be taken in overall systems design to insure fail-safe operation is achieved for all possible conditions. This topic was discussed previously in this Note.

Figure 25 shows a circuit to monitor a fuse or a circuit breaker. With this circuit, consideration must be given to Fail-Safe operation. Note that if the load is a very high impedance, there might not be sufficient current to operate the MID400. In other words, the output of MID400 is low on an open fuse or breaker. If V_{CC} to the MID400 is off and the fuse opens, no MID400 indication will result.

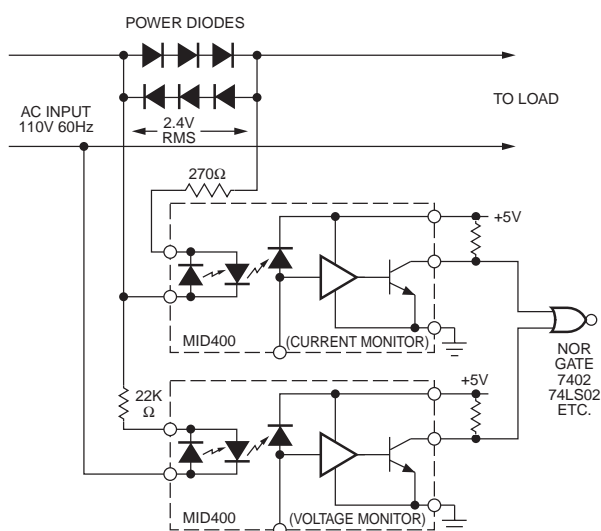

Figure 24. AC Power Line Voltage and Current Monitor

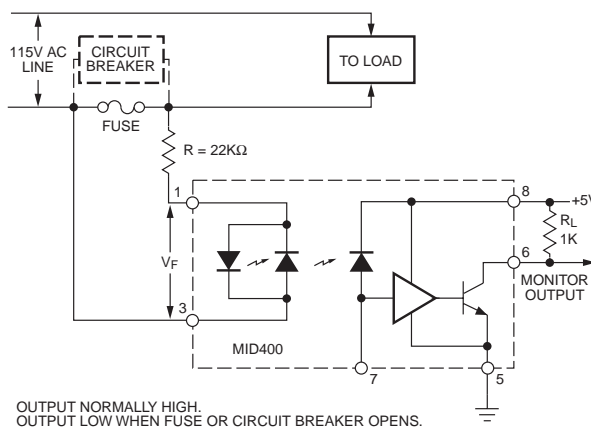
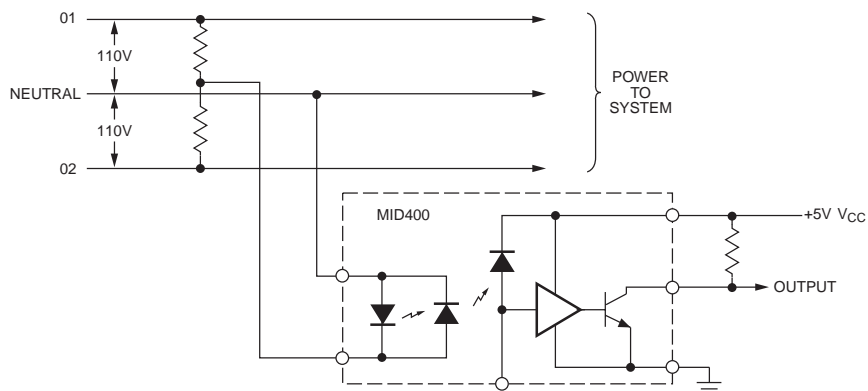
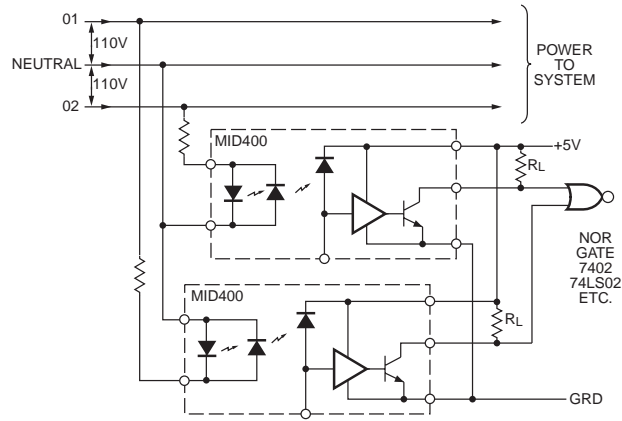

Figure 25. Fuse or Circuit Breaker Monitor



NOTE: Circuit detects failure of either but not both phases
 Figure 26. Monitor Circuit for Two Phase Power Line



NOTE: Circuit detects failure of either or both phases
Figure 27. Alternate Monitor Circuit for Two Phase Power Line

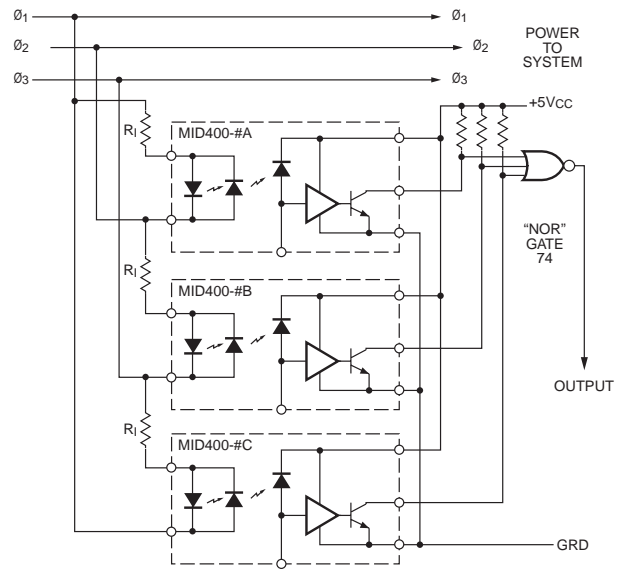

Figure 28. Monitor Circuit for Three Phase Power Line

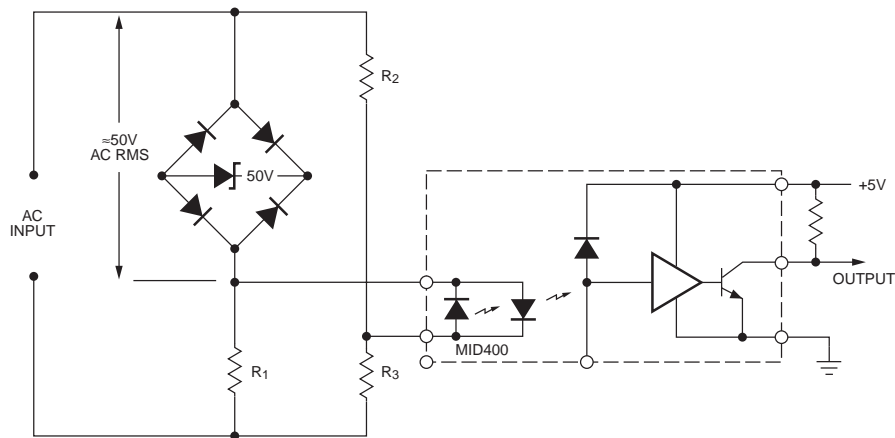

Figure 29. AC Voltage Deviation Monitor

Additional Application Ideas

The following circuits are included for their intrinsic value, but may need further refining for use in a specific application.

Figure 26 shows a circuit to detect failure of either but not **both** phases on a two phase AC power line. The MID400 output goes LOW when a phase fails. Figure 27 shows a more complicated circuit that will detect failure of either or both phases on a two phase line. The NOR gate output stays HIGH so long as **both** phases are present, but switches to LOW if either or both phases fail.

Figure 28 shows a circuit to monitor a three phase line. This circuit detects a failure on a single phase, as well as all phases failing simultaneously. The output from the NOR gate is normally high when all phases are present.

The input current limiting resistor R_1 is chosen so the MID400s operate in saturated mode. If a phase fails, for example phase \emptyset_1 goes open circuit, this effectively places MID400's #A and #B in series, causing them now to operate in non-saturated mode and produce 120Hz pulses. Therefore the output "NOR" gate outputs pulses to indicate phase failure. The output NOR gate is low when there is no power on any phase.

In some applications, for example when monitoring the power to a three phase motor, if a phase opens when the motor is running, it might run “single phase.” The motor might then generate sufficient back EMF on the open phase to maintain the input current to the MID400, and under such a condition this MID400 monitoring system is not effective.

Figure 29 illustrates the basic circuit concept for an AC voltage deviation monitor. Here the zener diode and bridge rectifier establish a given AC voltage, irrespective of AC input voltage, over a given range. This is compared with the voltage developed by R_2 and R_3 . Depending upon the choice of zener voltage and ratio of R_2 and R_3 , the circuit can operate in a number of modes:

1. Voltage Deviation Monitor to give a low output when the AC voltage deviates from a set standard. The voltage at the junction of R_2 and R_3 is made equal to the zener voltage for a given AC input voltage. A deviation from the standard causes current flow through the MID400's diodes.
2. Over Voltage Monitor (over a given range). For normal AC input voltage, R_2 and R_3 are chosen for a current flow through the MID400; when AC input voltage goes too high, the current ceases through the MID400 input diodes.
3. Under Voltage Monitor (over a given range). Similar to above, except R_2 and R_3 are chosen so current through the MID400 input diodes ceases if AC with low input voltage is too low.

It should be noted that in this circuit the magnitude of current through the MID400 input diodes is governed by choice of R_1 , R_2 and R_3 resistor values.

MID400 Benefits

This small size device connects through an external resistor directly to AC power lines and offers both input-to-output noise immunity as well as electrical surge isolation, up to 2500 VRMS (or 3550 VDC). Its output is compatible with TTL logic. Also the MID400 is UL recognized (File #E90700, Volume 2), has low power consumption, and operates from a single V_{CC} supply up to 7 volts. Besides inputs from power lines, the MID400 can also be connected to AC surges of other frequencies and even to DC sources (for detection of power). Output current is 16mA when a minimum 4mA RMS input current is applied to the input LEDs. When an inexpensive and readily available 555 Timer is connected to the MID400 output, circuits can be built having high sink and source current drive capabilities. These simple circuits can also be designed for a wide range of adjustable delays, and with rise and fall times compatible with TTL computer circuits.

Conclusion

This Application Note has summarized internal operation of the MID400 and described several classes of application circuits. Refer to the MID400 Data Sheet for a listing of Absolute Maximum Ratings and specifications for its Electrical Characteristics.

DISCLAIMER

FAIRCHILD SEMICONDUCTOR RESERVES THE RIGHT TO MAKE CHANGES WITHOUT FURTHER NOTICE TO ANY PRODUCTS HEREIN TO IMPROVE RELIABILITY, FUNCTION OR DESIGN. FAIRCHILD DOES NOT ASSUME ANY LIABILITY ARISING OUT OF THE APPLICATION OR USE OF ANY PRODUCT OR CIRCUIT DESCRIBED HEREIN; NEITHER DOES IT CONVEY ANY LICENSE UNDER ITS PATENT RIGHTS, NOR THE RIGHTS OF OTHERS.

LIFE SUPPORT POLICY

FAIRCHILD'S PRODUCTS ARE NOT AUTHORIZED FOR USE AS CRITICAL COMPONENTS IN LIFE SUPPORT DEVICES OR SYSTEMS WITHOUT THE EXPRESS WRITTEN APPROVAL OF THE PRESIDENT OF FAIRCHILD SEMICONDUCTOR CORPORATION. As used herein:

1. Life support devices or systems are devices or systems which, (a) are intended for surgical implant into the body, or (b) support or sustain life, or (c) whose failure to perform when properly used in accordance with instructions for use provided in the labeling, can be reasonably expected to result in significant injury to the user.
2. A critical component is any component of a life support device or system whose failure to perform can be reasonably expected to cause the failure of the life support device or system, or to affect its safety or effectiveness.

ON Semiconductor and  are trademarks of Semiconductor Components Industries, LLC dba ON Semiconductor or its subsidiaries in the United States and/or other countries. ON Semiconductor owns the rights to a number of patents, trademarks, copyrights, trade secrets, and other intellectual property. A listing of ON Semiconductor's product/patent coverage may be accessed at www.onsemi.com/site/pdf/Patent-Marking.pdf. ON Semiconductor reserves the right to make changes without further notice to any products herein. ON Semiconductor makes no warranty, representation or guarantee regarding the suitability of its products for any particular purpose, nor does ON Semiconductor assume any liability arising out of the application or use of any product or circuit, and specifically disclaims any and all liability, including without limitation special, consequential or incidental damages. Buyer is responsible for its products and applications using ON Semiconductor products, including compliance with all laws, regulations and safety requirements or standards, regardless of any support or applications information provided by ON Semiconductor. "Typical" parameters which may be provided in ON Semiconductor data sheets and/or specifications can and do vary in different applications and actual performance may vary over time. All operating parameters, including "Typicals" must be validated for each customer application by customer's technical experts. ON Semiconductor does not convey any license under its patent rights nor the rights of others. ON Semiconductor products are not designed, intended, or authorized for use as a critical component in life support systems or any FDA Class 3 medical devices or medical devices with a same or similar classification in a foreign jurisdiction or any devices intended for implantation in the human body. Should Buyer purchase or use ON Semiconductor products for any such unintended or unauthorized application, Buyer shall indemnify and hold ON Semiconductor and its officers, employees, subsidiaries, affiliates, and distributors harmless against all claims, costs, damages, and expenses, and reasonable attorney fees arising out of, directly or indirectly, any claim of personal injury or death associated with such unintended or unauthorized use, even if such claim alleges that ON Semiconductor was negligent regarding the design or manufacture of the part. ON Semiconductor is an Equal Opportunity/Affirmative Action Employer. This literature is subject to all applicable copyright laws and is not for resale in any manner.

PUBLICATION ORDERING INFORMATION

LITERATURE FULFILLMENT:

Literature Distribution Center for ON Semiconductor
19521 E. 32nd Pkwy, Aurora, Colorado 80011 USA
Phone: 303-675-2175 or 800-344-3860 Toll Free USA/Canada
Fax: 303-675-2176 or 800-344-3867 Toll Free USA/Canada
Email: orderlit@onsemi.com

N. American Technical Support: 800-282-9855 Toll Free
USA/Canada
Europe, Middle East and Africa Technical Support:
Phone: 421 33 790 2910
Japan Customer Focus Center
Phone: 81-3-5817-1050

ON Semiconductor Website: www.onsemi.com
Order Literature: <http://www.onsemi.com/orderlit>
For additional information, please contact your local
Sales Representative