

ADP3207C

7-Bit Programmable, Multi-Phase Mobile, CPU Synchronous Buck Controller

The ADP3207C is a high efficiency, multi-phase, synchronous, buck-switching regulator controller optimized for converting notebook battery voltage into the core supply voltage required by high performance Intel processors. The part uses an internal 7-bit Digital-to-Analog Converter (DAC) to read Voltage Identification (VID) code directly from the processor that sets the output voltage. The phase relationship of the output signals can be programmed to provide 1-, 2-, or 3-phase operation, allowing for the construction of up to three interleaved buck-switching stages.

The ADP3207C uses a multi-mode architecture to drive the logic-level PWM outputs at a programmable switching frequency that can be optimized depending on the output current requirement. The part switches between multi-phase and single-phase operation to maximize its effectiveness under all load conditions. In addition, the ADP3207C includes a programmable slope function to adjust the output voltage as a function of the load current. As a result, it is always best positioned for a system transient.

The chip also provides accurate and reliable short-circuit protection, adjustable current limiting, and a delayed power-good output that accommodates On-the-Fly (OTF) output voltage changes requested by the CPU.

The ADP3207C is specified over the extended commercial temperature range of -10°C to 100°C and is available in a 40-lead LFCSP.

The ADP3207CF has a soft-start time one tenth of ADP3207C. There are no other differences between the ADP3207C and ADP3207CF.

Features

- 1-, 2-, or 3-Phase Operation at Up to 750 kHz per Phase
- ± 7 mV Worst-Case Differential Sensing Error
Overtemperature
- Input Voltage Range of 3.3 V to 22 V
- Interleaved PWM Outputs for Driving External High Power MOSFET Drivers
- Enhanced PWM FlexMode™ for Excellent Load Transient Performance
- Automatic Power-Saving Modes Maximize Efficiency During Light Load and Deeper Sleep Operation
- Soft Transient Control Reduces Inrush Current and Audio Noise
- Active Current Balancing Between Output Phases

- Independent Current Limit and Load Line Setting Inputs for Additional Design Flexibility
- Built-In, Power-Good Masking Supports VID OTF
- 7-Bit Digitally Programmable 0.3 V to 1.5 V Output
- Overload and Short-Circuit Protection Latchoff Delay
- Built-In, Clock Enable Output Delays CPU Clock Until CPU Supply Voltage Stabilizes
- Current Monitor Output Signals the Total Output Power of the Buck Converter
- This is a Pb-Free Device

Applications

- Notebook Power Supplies for Next Generation Intel® Processors



ON Semiconductor®

<http://onsemi.com>

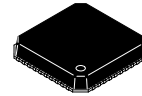

LFCSP40
CASE 932AC

MARKING DIAGRAMS

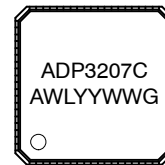

A = Assembly Location
WL = Wafer Lot
YYWW = Date Code
G = Pb-Free Package

ORDERING INFORMATION

See detailed ordering and shipping information in the package dimensions section on page 31 of this data sheet.

ADP3207C

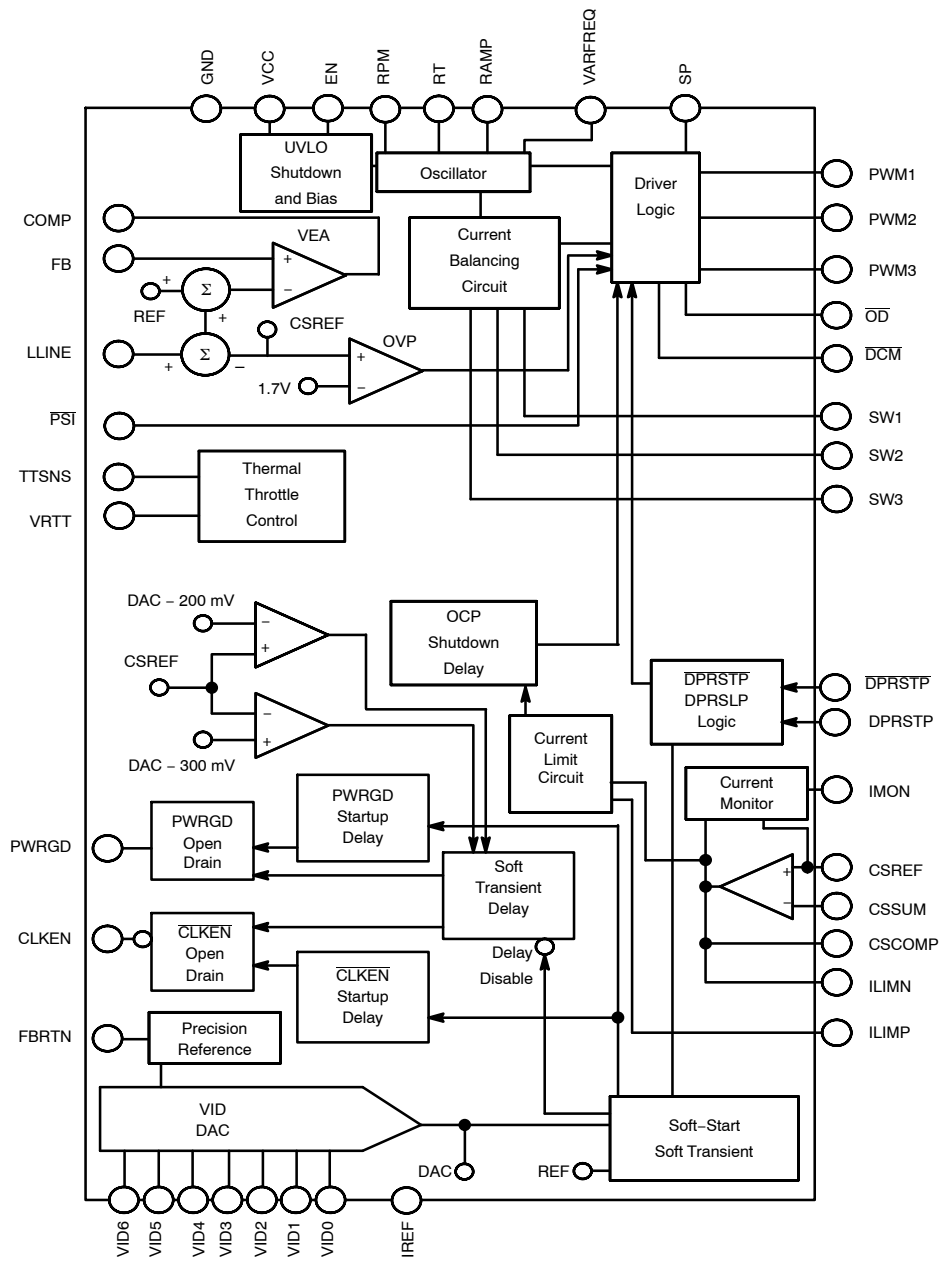

Figure 1. Functional Block Diagram

ADP3207C

ABSOLUTE MAXIMUM RATINGS

Parameter	Rating	Unit
V _{CC}	-0.3 to +6.0	V
FBRTN	-0.3 to +0.3	V
SW1 to SW3 DC t < 200 ns	-5 to +22 -10 to +28	V
RAMPADJ (In Shutdown)	-0.3 to +22	V
All Other Inputs and Outputs	-0.3 to V _{CC} + 0.3	V
Storage Temperature Range	-65 to +150	°C
Operating Ambient Temperature Range	-10 to 100	°C
Operating Junction Temperature	125	°C
Thermal Impedance (θ_{JA})	98	°C/W
Lead Temperature		°C
Soldering (10 sec)	300	
Infrared (15 sec)	260	

Stresses exceeding Maximum Ratings may damage the device. Maximum Ratings are stress ratings only. Functional operation above the Recommended Operating Conditions is not implied. Extended exposure to stresses above the Recommended Operating Conditions may affect device reliability.

NOTE: This device is ESD sensitive. Use standard ESD precautions when handling.

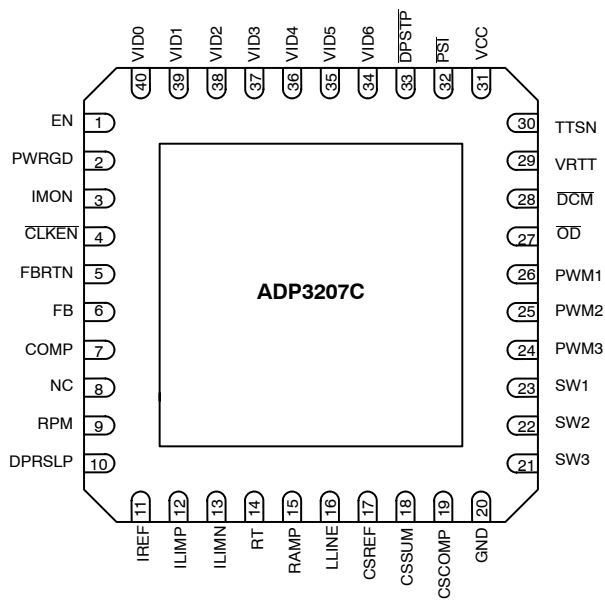

Figure 2. Pin Configuration
(Top View)

ADP3207C

PIN FUNCTION DESCRIPTIONS

Pin No	Mnemonic	Description
1	EN	Power Supply Enable Input. Pulling this pin to GND disables the PWM outputs and pulls the PWRGD output low.
2	PWRGD	Power-Good Output. Open-drain output that signals when the output voltage is outside of the proper operating range. The pull-high voltage on this pin cannot be higher than V_{CC} .
3	IMON	Current Monitor Output. This pin sources a current proportional to the output load current. A resistor to FBRTN sets the current monitor gain.
4	\overline{CLKEN}	Clock Enable Output. The pull-high voltage on this pin cannot be higher than V_{CC} .
5	FBRTN	Feedback Return. VID DAC and error amplifier reference for remote sensing of the output voltage.
6	FB	Feedback Input. Error amplifier input for remote sensing of the output voltage.
7	COMP	Error Amplifier Output and Compensation Point.
8	NC	Not Connected.
9	RPM	RPM Mode Timing Control Input. A resistor between this pin to ground sets the RPM mode turn-on threshold voltage.
10	DPRSLP	Deeper Sleep Control Input.
11	IREF	This pin sets the internal bias currents. A 80k Ω resistor is connected from this pin to ground.
12	ILIMP	Current Limit Set. An external resistor from ILIMN to ILIMP sets the current limit threshold of the converter.
13	ILIMN	Current Limit Set. An external resistor from ILIMN to ILIMP sets the current limit threshold of the converter.
14	RT	Multi-phase Frequency Setting Input. An external resistor connected between this pin and GND sets the oscillator frequency of the device when operating in multi-phase PWM mode.
15	RAMPADJ	PWM Ramp Current Input. An external resistor from the converter input voltage to this pin sets the internal PWM ramp.
16	LLSET	Output Load Line Programming Input. The center point of a resistor divider between CSREF and CSCOMP is connected to this pin to set the load line slope.
17	CSREF	Current Sense Reference Voltage Input. The voltage on this pin is used as the reference for the current sense amplifier and the power-good and crowbar functions. This pin should be connected to the common point of the output inductors.
18	CSSUM	Current Sense Summing Node. External resistors from each switch node to this pin sum the inductor currents together to measure the total output current.
19	CSCOMP	Current Sense Compensation Point. A resistor and capacitor from this pin to CSSUM determine the gain of the current sense amplifier and the positioning loop response time.
20	GND	Ground. All internal biasing and the logic output signals of the device are referenced to this ground.
21 to 23	SW3 to SW1	Current Balance Inputs. Inputs for measuring the current level in each phase. The SW pins of unused phases should be left open.
24 to 26	PWM3 to PWM1	Logic-Level PWM Outputs. Each output is connected to the input of an external MOSFET driver, such as the ADP3611. Connecting the PWM2 and/or PWM3 outputs to V_{CC} causes that phase to turn off, allowing the ADP3207C to operate as a 1-, 2-, or 3-phase controller.
27	\overline{OD}	Multi-phase Output Disable Logic Output. This pin is actively pulled low when the ADP3207C enters single-phase mode or during shutdown. Connect this pin to the SD inputs of the Phase 2 and Phase 3 MOSFET drivers.
28	DCM	Discontinuous Current Mode Enable Output. This pin is actively pulled low when the single-phase inductor current crosses zero.
29	VRTT	Voltage Regulator Thermal Throttling Logic Output. This pin goes high if the temperature at the monitoring point connected to TTSENSE exceeds the programmed VRTT temperature threshold.
30	TTSENSE	Thermal Throttling Sense Input and OVP Disable. The center point of a resistor divider (where the lower resistor is an NTC thermistor) between V_{CC} and GND is connected to this pin to remotely sense the temperature at the desired thermal monitoring point. Connect TTSENSE V_{CC} if Thermal Throttling is not used.
31	VCC	Supply Voltage for the Device.
32	PSI	Power State Indicator Input. Pulling this pin to GND forces the ADP3207C to operate in single-phase mode.
33	DRPSTP	Deeper Stop Control Input.
34 to 40	VID6 to VID0	Voltage Identification DAC Inputs. When in normal operation mode, the DAC output programs the FB regulation voltage from 0.3 V to 1.5 V (see Table 3).

ADP3207C

ELECTRICAL CHARACTERISTICS $V_{CC} = 5.0\text{ V}$, $FBRN = GND$, $EN = V_{CC}$, $V_{VID} = 0.50\text{ V to }1.5000\text{ V}$, $\overline{PS1} = 1.05\text{ V}$, $DPRSLP = GND$, $DPRSTP = 1.05\text{ V}$, $LLSET = CSREF$, $T_A = -10^\circ\text{C to }100^\circ\text{C}$, unless otherwise noted (Note 1). $R_{REF} = 80\text{ k}\Omega$. Current entering a pin (sunk by the device) has a positive sign.

Parameter	Symbol	Conditions	Min	Typ	Max	Unit
VOLTAGE CONTROL – Voltage Error Amplifier (VEAMP)						
FB, LLINE Voltage Range (Note 2)	V_{FB}, V_{LLINE}	Relative to $CSREF = V_{DAC}$	-200		+200	mV
FB, LLINE Offset Voltage (Note 2)	V_{OSVEA}	Relative to $CSREF = V_{DAC}$	-0.5		+0.5	mV
FB Bias Current (Note 2)	I_{FB}		-1.0		1.0	A
LLINE Bias Current (Note 2)	I_{LL}		-50		50	nA
LLINE Positioning Accuracy	$V_{FB} - V_{VID}$	Measured on FB relative to V_{VID} , LLINE forced 80 mV below $CSREF$	-78	-80	-82	mV
COMP Voltage Range	V_{COMP}	Operating Range	0.85		4.0	V
COMP Current	I_{COMP}	COMP = 2.0 V, $CSREF = V_{DAC}$ FB forced 200 mV below $CSREF$ FB forced 200 mV above $CSREF$		0.75 6.0		mA
COMP Slew Rate	SR_{COMP}	$C_{COMP} = 10\text{ pF}$, $CSREF = V_{DAC}$, Open loop configuration FB forced 200 mV below $CSREF$ FB forced 200 mV above $CSREF$		15 -20		V/ μ s
Gain Bandwidth (Note 2)	GBW	Non-inverting unit gain configuration, $R_{FB} = 1\text{ k}\Omega$		20		MHz

VID DAC VOLTAGE REFERENCE

V_{DAC} Voltage Range		See VID Code Table	0		1.5	V
V_{DAC} Accuracy	$V_{FB} - V_{VID}$	Measured on FB (includes offset), relative to V_{VID} , for VID table see Table 3, $T_A = -10^\circ\text{C to }85^\circ\text{C}$ $V_{VID} = 1.2125\text{ V to }1.5000\text{ V}$ $V_{VID} = 0.3000\text{ V to }1.2000\text{ V}$	-9.0 -7.0		+9.0 +7.0	mV
V_{DAC} Differential Non-linearity (Note 2)			-1.0		+1.0	LSB
V_{DAC} Line Regulation	ΔV_{FB}	$V_{CC} = 4.75\text{ V to }5.25\text{ V}$		0.05		%
V_{DAC} Boot Voltage	V_{BOOTFB}	Measured during boot delay period		1.200		V
Soft-Start Delay (Note 2)	t_{DSS}	Measured from EN pos edge to $FB = 50\text{ mV}$		200		μ s
Soft-Start Time	t_{SS}	Measured from EN pos edge to FB settles to $V_{BOOT} = 1.2\text{ V}$ within -5% ADP3207C ADP3207CF		1.4 0.14		ms
Boot Delay	t_{BOOT}	Measured from FB settling to $V_{BOOT} = 1.2\text{ V}$ within -5% to $CLKEN$ neg edge		100		μ s
V_{DAC} Slew Rate		Soft-Start ADP3207C Soft-Start ADP3207CF Non-LSB VID step, $DPRSLP = H$, Slow C4 Entry/Exit Non-LSB VID step, $DPRSLP = L$, Fast C4 Exit		0.0625 0.625 0.25 1.0		LSB/ ms
FBRN Current	I_{FBRN}			90	200	μ A

VOLTAGE MONITORING AND PROTECTION – Power Good

CSREF Undervoltage Threshold	$V_{UVCSREF}$	Relative to nominal DAC Voltage: = 0.5125 V to 1.5 V = 0.3 V to 0.5 V	-240 -160	-300 -300	-360 -360	mV
CSREF Overvoltage Threshold	$V_{OVCSREF}$	Relative to nominal DAC Voltage	150	200	250	mV
CSREF Crowbar Voltage Threshold	$V_{CBCSREF}$	Relative to FBRN	1.65	1.7	1.75	V

1. All limits at temperature extremes are guaranteed via correlation using standard Statistical Quality Control (SQC).
2. Guaranteed by design or bench characterization, not production tested.

ADP3207C

ELECTRICAL CHARACTERISTICS $V_{CC} = 5.0\text{ V}$, $F_{BRTN} = \text{GND}$, $EN = V_{CC}$, $V_{VID} = 0.50\text{ V}$ to 1.5000 V , $\overline{PSI} = 1.05\text{ V}$, $DPRSLP = \text{GND}$, $\overline{DPRSTP} = 1.05\text{ V}$, $LLSET = \text{CSREF}$, $T_A = -10^\circ\text{C}$ to 100°C , unless otherwise noted (Note 1). $R_{REF} = 80\text{ k}\Omega$. Current entering a pin (sunk by the device) has a positive sign.

Parameter	Symbol	Conditions	Min	Typ	Max	Unit
-----------	--------	------------	-----	-----	-----	------

VOLTAGE MONITORING AND PROTECTION – Power Good

CSREF Reverse Voltage Threshold	$V_{RVCSREF}$	Relative to F_{BRTN} , Latchoff mode: CSREF Falling CSREF Rising	-350	-300 -70	-5.0	mV
PWRGD Low Voltage	V_{PWRGD}	$I_{PWRGD}(\text{SINK}) = 4\text{ mA}$		85	150	mV
PWRGD High, Leakage Current	I_{PWRGD}	$V_{PWRGD} = 5.0\text{ V}$			1.0	μA
PWRGD Startup Delay	$T_{SSPWRGD}$	Measured from $CLKEN$ neg edge to PWRGD Pos Edge		8.0		ms
PWRGD Latchoff Delay	$T_{LOFFPWRGD}$	Measured from Out-off-Good-Window event to Latchoff (switching stops)		8.0		ms
PWRGD Propagation Delay	$T_{PDPWRGD}$	Measured from Out-off-Good-Window event to PWRGD neg edge		200		ns
Crowbar Latchoff Delay (Note 2)	T_{LOFFCB}	Measured from Crowbar event to Latchoff (switching stops)		200		ns
PWRGD Masking Time		Triggered by any VID change or OCP event		100		μs
CSREF Soft-Stop Resistance		$EN = \text{L}$ or Latchoff condition		70		Ω

CURRENT CONTROL – Current Sense Amplifier (CSAMP)

CSSUM, CSREF Common-Mode Range (Note 2)		Voltage range of interest	0		2.0	V
CSSUM, CSREF Offset Voltage	V_{OSCSA}	CSREF – CSSUM, $T_A = -10^\circ\text{C}$ to 85°C $T_A = 25^\circ\text{C}$	-1.7 -0.5		+1.7 +0.5	mV
CSSUM Bias Current	I_{BCSSUM}		-50		+50	nA
CSREF Bias Current	I_{BCSREF}		-50		+50	nA
CSCOMP Voltage Range (Note 2)		Operating Range	0.05		2.0	V
CSCOMP Current	$I_{CSCOMPsource}$ $I_{CSCOMPsink}$	CSCOMP = 2.0 V CSSUM forced 200 mV below CSREF CSSUM forced 200 mV above CSREF		-750 1.0		μA mA
CSCOMP Slew Rate		$C_{CSCOMP} = 10\text{ pF}$, Open Loop Configuration CSSUM forced 200 mV below CSREF CSSUM forced 200 mV above CSREF		10 -10		V/ μs
Gain Bandwidth (Note 2)	GBW_{CSA}	Non-inverting unit gain configuration $R_{FB} = 1\text{ k}\Omega$		20		MHz

CURRENT MONITORING AND PROTECTION

Current Reference I_{REF} Voltage	V_{REF}	$R_{REF} = 80\text{ k}\Omega$ to set $I_{REF} = 20\text{ }\mu\text{A}$	1.55	1.6	1.65	V
Current Limiter (OCP) Current Limit Threshold	V_{LIMTH}	Measured from CSCOMP to CSREF, $R_{LIM} = 4.5\text{ k}\Omega$, 2-ph configuration, $\overline{PSI} = \text{H}$ 2-ph configuration, $\overline{PSI} = \text{L}$ Measured from CSCOMP to CSREF, $R_{LIM} = 4.5\text{ k}\Omega$, 3-ph configuration, $\overline{PSI} = \text{H}$ 3-ph configuration, $\overline{PSI} = \text{L}$ 1-ph configuration	-70 -30	-90 -45	-115 -65	mV
Current Limit Latchoff Delay		Measured from OCP event to PWRGD deassertion		8.0		ms

1. All limits at temperature extremes are guaranteed via correlation using standard Statistical Quality Control (SQC).
2. Guaranteed by design or bench characterization, not production tested.

ADP3207C

ELECTRICAL CHARACTERISTICS $V_{CC} = 5.0$ V, $FBRTN = GND$, $EN = V_{CC}$, $V_{VID} = 0.50$ V to 1.5000 V, $\overline{PSI} = 1.05$ V, $DPRSLP = GND$, $\overline{DPRSTP} = 1.05$ V, $LLSET = CSREF$, $T_A = -10^\circ\text{C}$ to 100°C , unless otherwise noted (Note 1). $R_{REF} = 80$ k Ω . Current entering a pin (sunk by the device) has a positive sign.

Parameter	Symbol	Conditions	Min	Typ	Max	Unit
-----------	--------	------------	-----	-----	-----	------

CURRENT MONITOR

Current Gain Accuracy	I_{MON}/I_{LIM}	Measured from I_{LIMP} to I_{MON} $I_{LIM} = -20$ μA $I_{LIM} = -10$ μA	9.3 9.2	10 10	10.7 10.8	
I_{MON} Clamp Voltage	V_{MAXMON}	Relative to $FBRTN$, $I_{LIMP} = -30$ μA	1.05		1.15	V

PULSE WIDTH MODULATOR – Clock Oscillator

R_T Voltage	V_{RT}	$R_T = 125$ k Ω , $V_{VID} = 1.4000$ V See also $V_{RT}(V_{VID})$ formula	1.12	1.2	1.28	V
PWM Clock Frequency Range (Note 2)	f_{CLK}	Operating Range	0.3		3.0	MHz
PWM Clock Frequency	f_{CLK}	$T_A = +25^\circ\text{C}$, $V_{VID} = 1.2000$ V $R_T = 73$ k Ω $R_T = 125$ k Ω $R_T = 180$ k Ω	1150 500	1450 850 630	1750 780	kHz

RAMP GENERATOR

RAMP Voltage	V_{RAMP}	$EN = \text{high}$, $I_{RAMP} = 30$ μA $EN = \text{low}$	0.9	1.0 V_{IN}	1.1	V
RAMP Current Range (Note 2)	I_{RAMP}	$EN = \text{high}$ $EN = \text{low}$, $RAMP = 19$ V	1.0 -0.5		100 +0.5	μA

PWM COMPARATOR

PWM Comparator Offset (Note 2)	V_{OSRPM}	$V_{RAMP} - V_{COMP}$	-3.0		3.0	mV
--------------------------------	-------------	-----------------------	------	--	-----	----

RPM COMPARATOR

RPM Current	I_{RPM}	$V_{VID} = 1.2$ V, $R_T = 125$ k Ω See also $I_{RPM}(R_T)$ formula		-8.8		μA
RPM Comparator Offset (Note 2)	V_{OSRPM}	$V_{COMP} - (1 + V_{RPM})$	-3.0		3.0	mV

EPWM CLOCK SYNC

Trigger Threshold (Note 2)		Relative to $COMP$ sampled T_{CLK} earlier 3-phase configuration 2-phase configuration 1-phase configuration		300 350 400		mV
----------------------------	--	---	--	-------------------	--	----

SWITCH AMPLIFIER

SW Common Mode Range (Note 2)	$V_{SW(X)CM}$	Operating Range for current sensing	-600		+200	mV
SW Input Resistance	$R_{SW(X)}$	$SW_X = 0$ V	20	32	45	k Ω

ZERO CURRENT SWITCHING COMPARATOR

SW ZCS Threshold	$V_{DCM(SW1)}$	DCM mode, $DPRSLP = 3.3$ V		-4.0		mV
Masked Off Time	$t_{OFFMSKD}$	Measured from PWM neg edge to PWM Pos Edge at max frequency of operation		700		ns

SYSTEM I/O BUFFERS VID[6:0], \overline{PSI} INPUTS

Input Voltage		Refers to driving signal level Logic low, $I_{sink} \geq 1$ μA Logic high, $I_{source} \leq -5$ μA	0.7		0.3	V
Input Current		$V = 0.2$ V $VID[6:0]$, $DPRSLP$ (active pulldown to GND) \overline{PSI} (active pullup to V_{CC})		-1.0 +2.0		μA
VID Delay Time (Note 2)		Any VID edge to FB change 10%	200			ns

1. All limits at temperature extremes are guaranteed via correlation using standard Statistical Quality Control (SQC).
2. Guaranteed by design or bench characterization, not production tested.

ADP3207C

ELECTRICAL CHARACTERISTICS $V_{CC} = 5.0\text{ V}$, $F_{BRTN} = \text{GND}$, $EN = V_{CC}$, $V_{VID} = 0.50\text{ V}$ to 1.5000 V , $\overline{PSI} = 1.05\text{ V}$, $DPRSLP = \text{GND}$, $\overline{DPRSTP} = 1.05\text{ V}$, $LLSET = \text{CSREF}$, $T_A = -10^\circ\text{C}$ to 100°C , unless otherwise noted (Note 1). $R_{REF} = 80\text{ k}\Omega$. Current entering a pin (sunk by the device) has a positive sign.

Parameter	Symbol	Conditions	Min	Typ	Max	Unit
DPRSLP						
Input Voltage		Refers to driving signal level Logic low, $I_{\text{sink}} \geq 1\ \mu\text{A}$ Logic high, $I_{\text{source}} \leq -5\ \mu\text{A}$	2.3		0.4	V
Input Current		DPRSLP = low DPRSLP = high		-1.0 +2.0		μA
DPRSTP						
Input Voltage (Note 2)		Refers to driving signal level Logic low, $I_{\text{sink}} \geq 1\ \mu\text{A}$ Logic high, $I_{\text{source}} \leq -5\ \mu\text{A}$	0.7		0.3	V
Input Current (Note 2)				1.0		μA
EN INPUT						
Input Voltage		Refers to driving signal level Logic low, $I_{\text{sink}} \geq 1\ \mu\text{A}$ Logic high, $I_{\text{source}} \leq -5\ \mu\text{A}$	2.3		0.3	V
Input Current		EN = L or EN = H (Static) $0.8\text{ V} < \text{EN} < 1.6\text{ V}$ (During Transition)		10 70		nA μA
CLKEN OUTPUT						
Output Low Voltage		Logic low, $I_{\text{sink}} = 4\text{ mA}$		30	200	mV
Output High, Leakage Current		Logic high, $V_{\text{CLKEN}} = V_{CC}$			1.0	μA
THERMAL MONITORING AND PROTECTION						
TTSNS Voltage Range (Note 2)			0		5.0	V
TTSNS Threshold		$V_{CC} = 5.0\text{ V}$, TTSNS is falling	2.45	2.5	2.55	V
TTSNS Bias Current		TTSNS = 2.6 V	-2.0		2.0	μA
VRTT Output Voltage	V_{VRTT}	Logic low, $I_{\text{VRTT(SINK)}} = 400\ \mu\text{A}$ Logic high, $I_{\text{VRTT(SOURCE)}} = -400\ \mu\text{A}$	4.0	10 5.0	50	mV V
TTSNS Hysteresis			50	100		mV
PWM, $\overline{\text{OD}}$, AND $\overline{\text{DCM}}$ OUTPUT						
Output Low Voltage		Logic Low, $I_{\text{SINK}} = 400\ \mu\text{A}$ Logic High, $I_{\text{SOURCE}} = -400\ \mu\text{A}$	4.0	10 5.0	200	mV V
SUPPLY						
Supply Voltage Range	V_{CC}		4.5		5.5	V
Supply Current		EN = H EN = 0 V		6.0 20	10 100	mA μA
V_{CC} OK Threshold	V_{CCOK}	V_{CC} is Rising		4.4	4.5	V
V_{CC} UVLO Threshold	V_{CCUVLO}	V_{CC} is Falling	4.0	4.15		V
V_{CC} Hysteresis (Note 2)				150		mV

1. All limits at temperature extremes are guaranteed via correlation using standard Statistical Quality Control (SQC).
2. Guaranteed by design or bench characterization, not production tested.

ADP3207C

TEST CIRCUITS

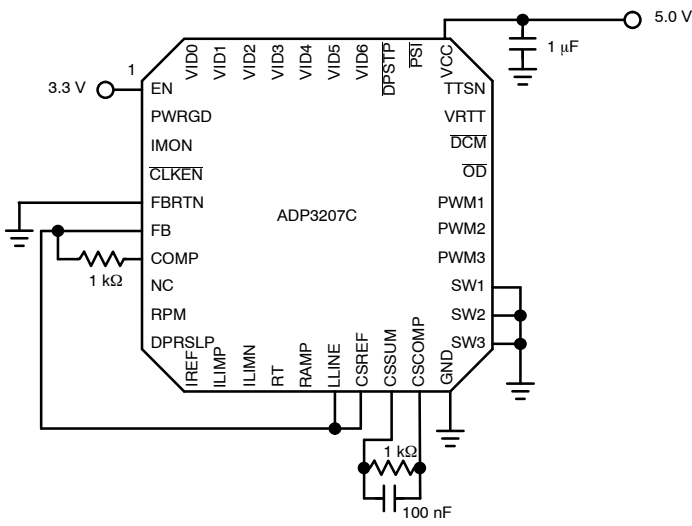

Figure 3. Closed-Loop Output Voltage Accuracy

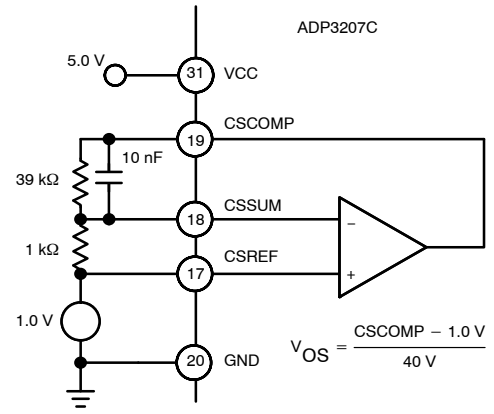

Figure 4. Current Sense Amplifier V_{OS}

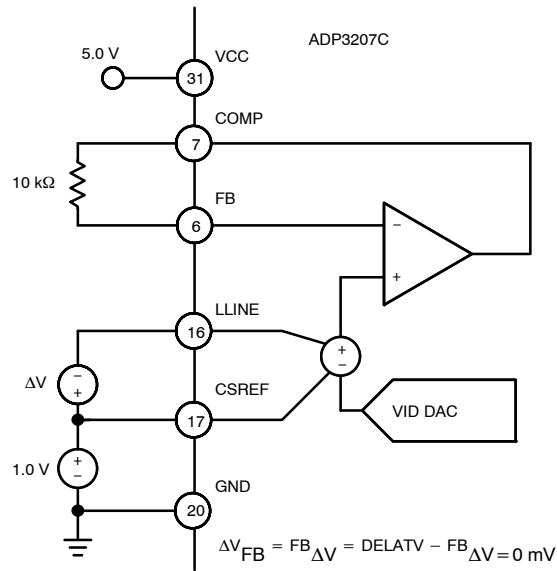

Figure 5. Positioning Accuracy

ADP3207C

TYPICAL PERFORMANCE CHARACTERISTICS

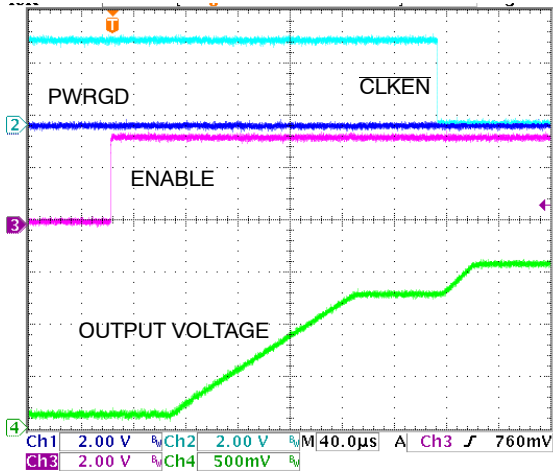

Figure 6. ADP3207CF Startup

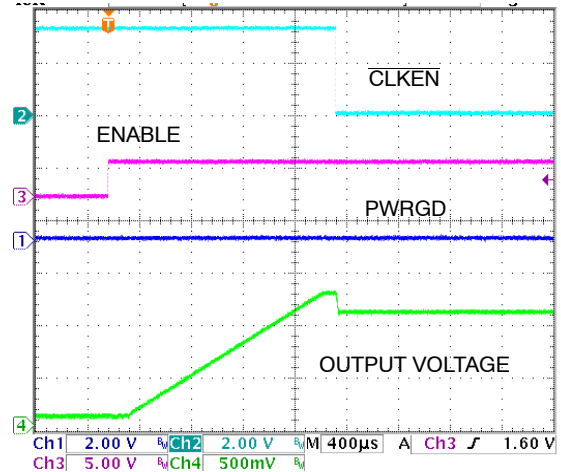

Figure 7. ADP3207C Startup

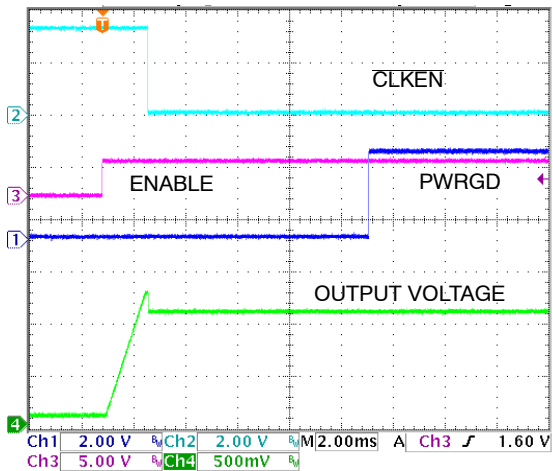

Figure 8. ADP3207C Startup

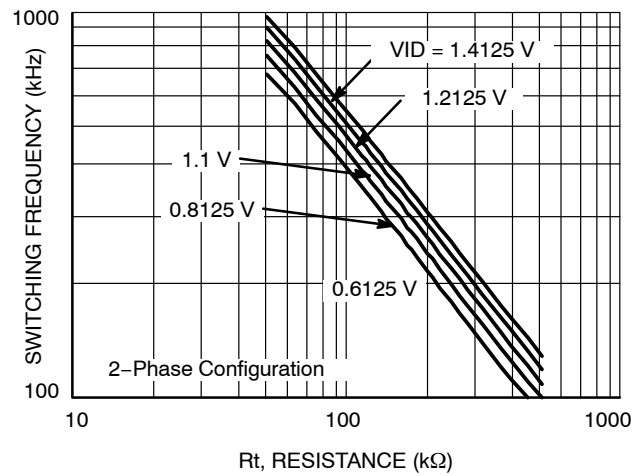

Figure 9. Per Phase Switching Frequency vs. RT Resistance

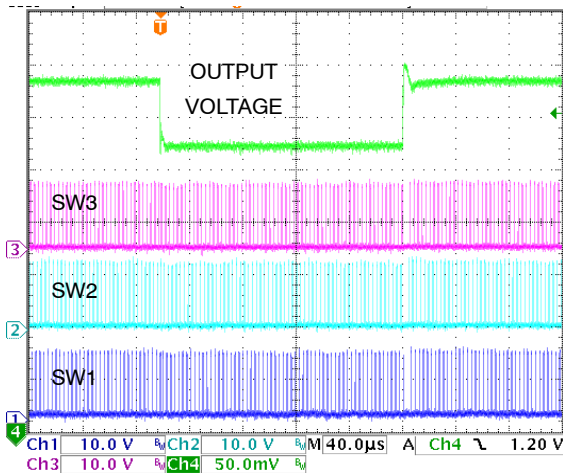

Figure 10. Load Transient

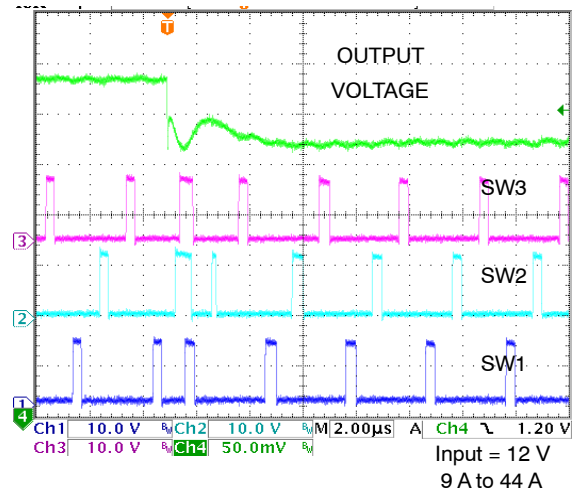

Figure 11. Load Transient

TYPICAL PERFORMANCE CHARACTERISTICS

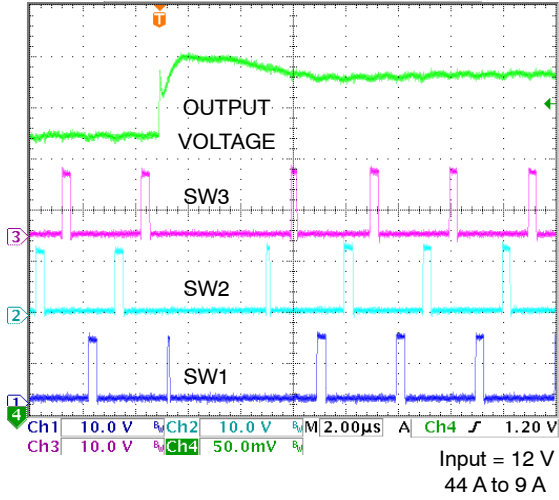

Figure 12. Load Transient

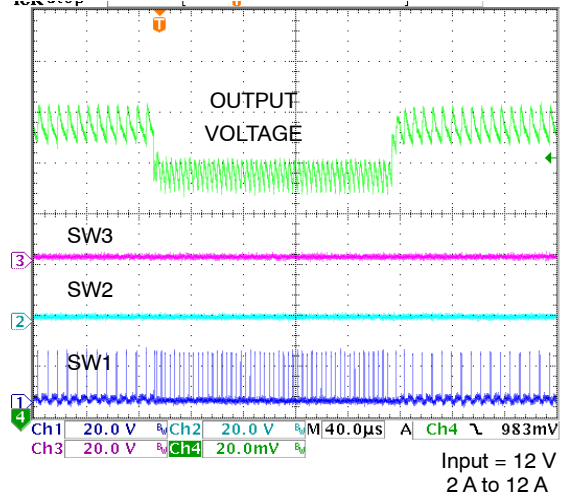

Figure 13. Single Phase Load Transient

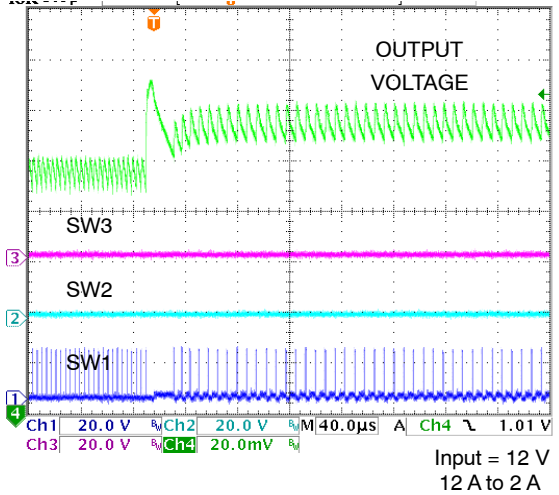

Figure 14. Single Phase Load Transient

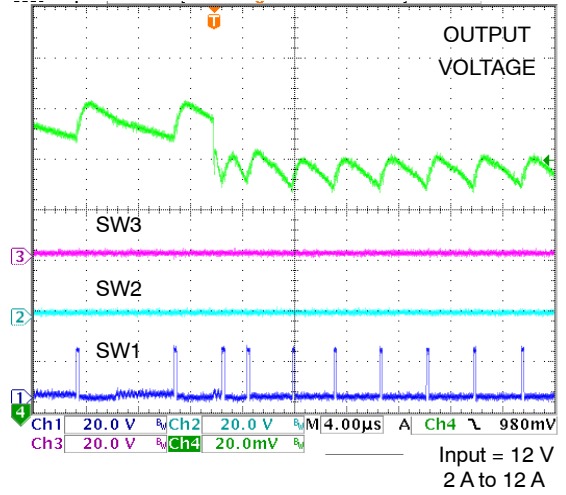

Figure 15. Single Phase Load Transient

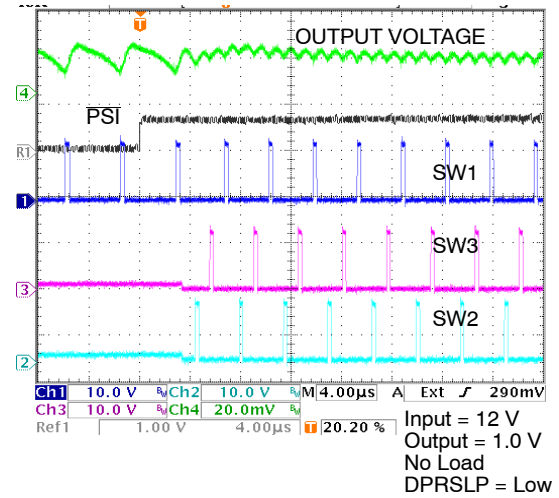

Figure 16. $\overline{\text{PSI}}$ Transition

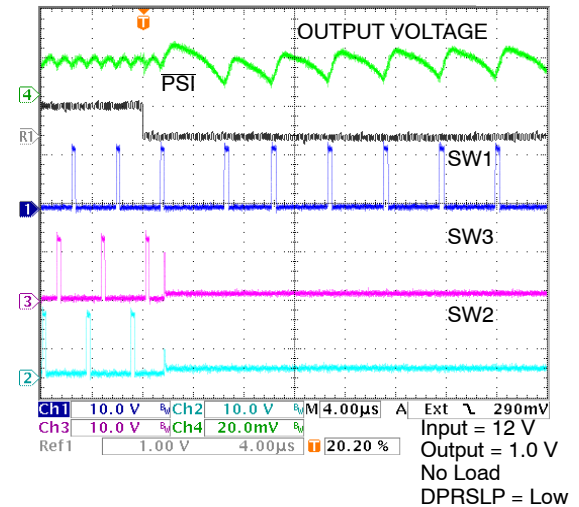

Figure 17. $\overline{\text{PSI}}$ Transition

TYPICAL PERFORMANCE CHARACTERISTICS

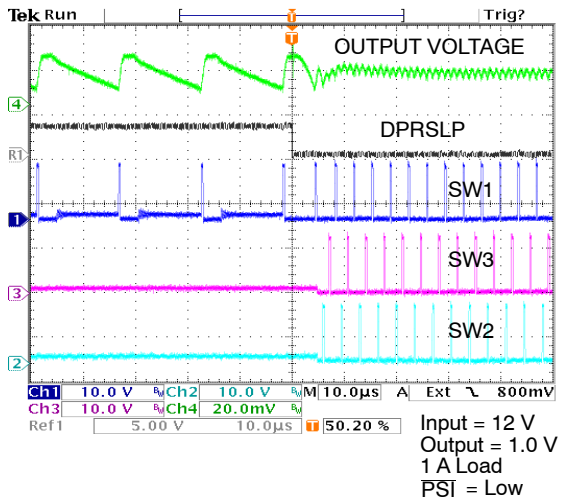

Figure 18. DPRSLP Transition

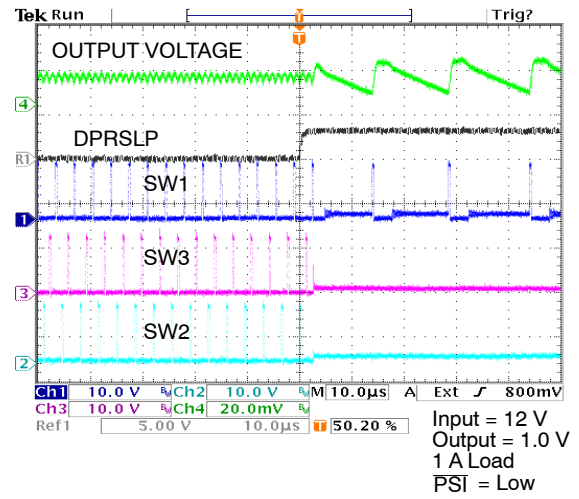

Figure 19. DPRSLP Transition

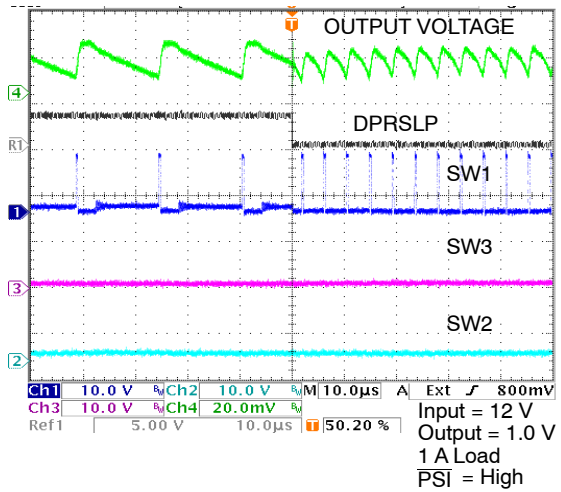

Figure 20. DPRSLP Transition

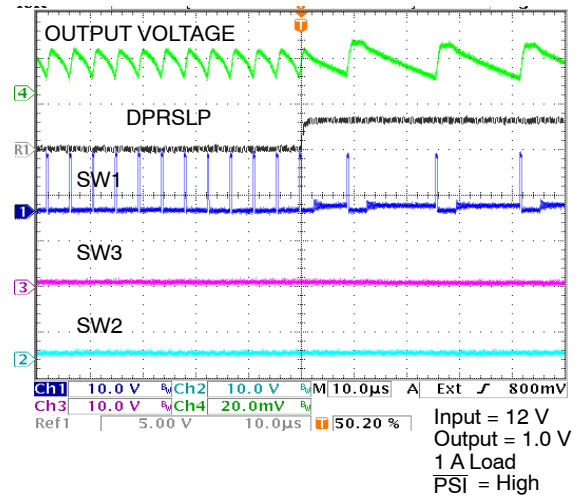

Figure 21. DPRSLP Transition

ADP3207C

TYPICAL PERFORMANCE CHARACTERISTICS

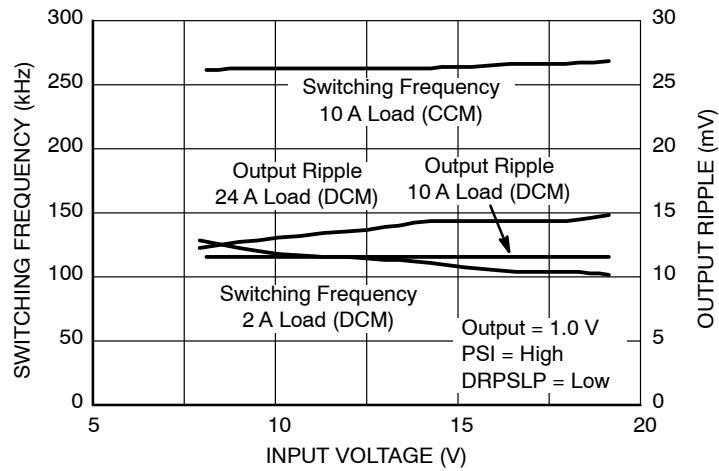

Figure 22. Switching Frequency and Output Ripple in RPM

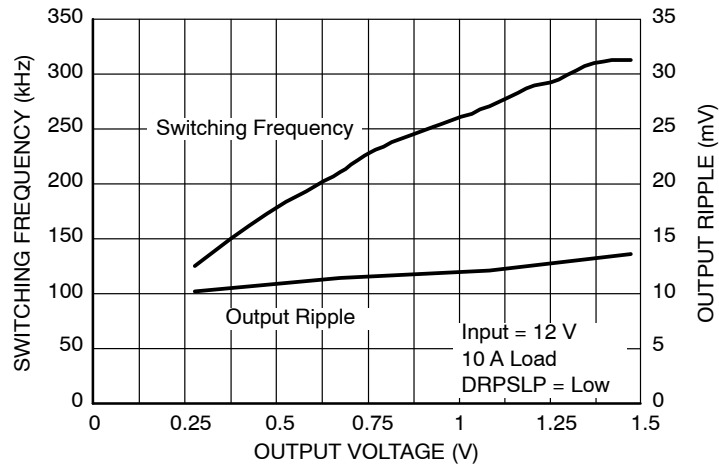

Figure 23. Switching Frequency and Output Ripple in RPM

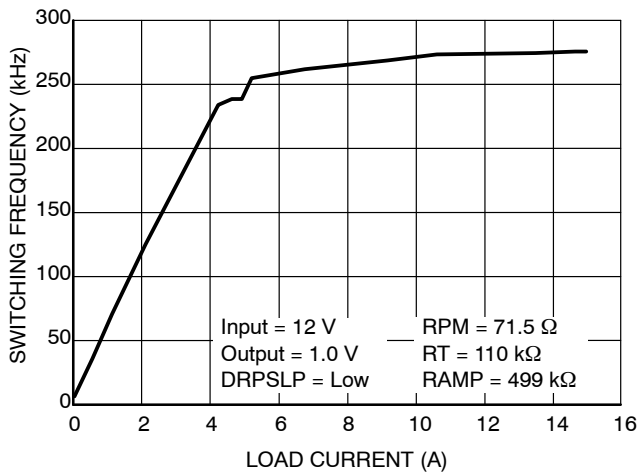

Figure 24. Switching Frequency in RPM

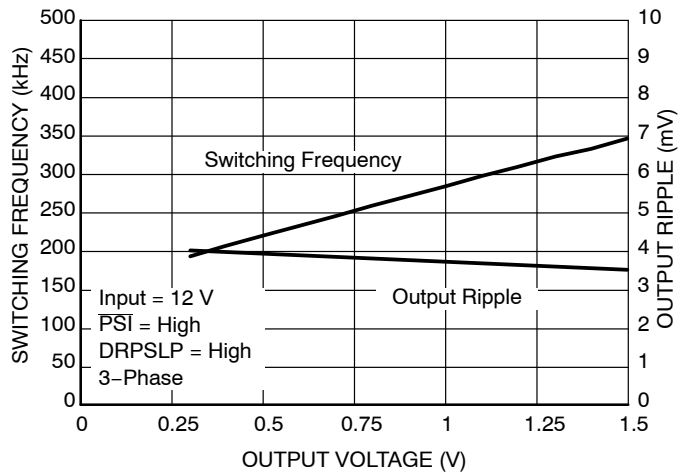

Figure 25. Switching Frequency in PWM

Theory of Operation

The ADP3207C combines a multi-mode Ramp Pulse Modulated (PWM/RPM) control with multi-phase logic outputs for use in 1-, 2-, and 3-phase synchronous buck CPU core supply power converters. The internal 7-bit VID DAC conforms to Intel IMVP-6 specifications. Multi-phase operation is important for producing the high currents and low voltages demanded by today's microprocessors. Handling high currents in a single-phase converter puts high thermal stress on the system components, such as the inductors and MOSFETs.

The multi-mode control of the ADP3207C ensures a stable high performance topology for:

- Balancing currents and thermals between phases
- High speed response at the lowest possible switching frequency and minimal output decoupling
- Minimizing thermal switching losses due to lower frequency operation
- Tight load line regulation and accuracy
- High current output by supporting up to 3-phase operation
- Reduced output ripple due to multi-phase ripple cancellation
- High power conversion efficiency both at heavy load and light load
- PC board layout noise immunity
- Ease of use and design due to independent component selection
- Flexibility in operation by allowing optimization of design for low cost or high performance

Number of Phases

The number of operational phases and their phase relationship is determined by internal circuitry that monitors the PWM outputs. Normally, the ADP3207C operates as a 3-phase controller. For 2-phase operation, the PWM3 pin is connected to V_{CC} 5.0 V programs, and for 1-phase operation, the PWM3 and PWM2 pins are connected to V_{CC} 5.0 V programs.

When the ADP3207C is initially enabled, the controller sinks 50 μ A on the PWM2 and PWM3 pins. An internal comparator checks the voltage of each pin against a high threshold of 3.0 V. If the pin voltage is high due to pullup to the V_{CC} 5.0 V rail, then the phase is disabled. The phase detection is made during the first three clock cycles of the internal oscillator. After phase detection, the 50 μ A current sink is removed. The pins that are not connected to the V_{CC}

5.0 V rail function as normal PWM outputs. The pins that are connected to V_{CC} enter into high impedance state.

The PWM outputs are 5.0 V logic-level signals intended for driving external gate drivers, such as the ADP3611. Because each phase is monitored independently, operation approaching 100% duty cycle is possible. In addition, more than one output can operate at a time to allow overlapping phases.

Operation Modes

For the ADP3207C, the number of phases can be selected by the user as described in the Number of Phases section, or they can dynamically change based on system signals to optimize the power conversion efficiency at heavy and light CPU loads.

During a VID transient or at a heavy load condition, indicated by DPRSLP going low and \overline{PSI} going high, the ADP3207C runs in full-phase mode. All user-selected phases operate in interleaved PWM mode, which results in minimal V_{Core} ripple and best transient performance. While in light load mode, indicated by either \overline{PSI} going low or DPRSLP going high, only Phase 1 of the ADP3207C is in operation to maximize power conversion efficiency.

In addition to the change of phase number, the ADP3207C dynamically changes operation modes. In multi-phase operation, the ADP3207C runs in PWM mode, with switching frequency controlled by the master clock. In single-phase mode based on the \overline{PSI} signal, the ADP3207C switches to RPM mode, where the switching frequency is no longer controlled by the master clock, but by the ripple voltage appearing on the COMP pin. The PWM1 pin is set to high each time the COMP pin voltage rises to a limit determined by the VID voltage and programmed by the external resistor connected between Pin VRPM and Pin RRPM. In single-phase mode based on the DPRSLP signal, the ADP3207C runs in RPM mode, with the synchronous rectifier (low-side) MOSFETs of Phase 1 being controlled by the \overline{DCM} pin to prevent any reverse inductor current. Thus, the switch frequency varies with the load current, resulting in maximum power conversion efficiency in deeper sleep mode of CPU operation. In addition, during any VID transient, system transient (entry/exit of deeper sleep), or current limit, the ADP3207C goes into full phase mode, regardless of DPRSLP and \overline{PSI} signals, eliminating current stress to Phase 1.

Table 1 summarizes how the ADP3207C dynamically changes phase number and operation modes based on system signals and operating conditions.

Table 1. Phase Number and Operation Modes

PSI	DPRSLP	VID Transient Period (Note 1)	Hit Current Limit	No. of Phases Selected by User	No. of Phases in Operation	Operation Mode
DNC	DNC	Yes	DNC	N 3, 2, or 1	N	PWM, CCM Only
1	0	No	DNC	N 3, 2, or 1	N	PWM, CCM Only
0	0	No	No	DNC	Phase 1 only	RPM, CCM Only
0	0	No	Yes	DNC	N	PWM, CCM Only
DNC	1	No	No	DNC	Phase 1 only	RPM, Automatic CCM / DCM
DNC	1	No	Yes	DNC	N	PWM, CCM Only

1. VID transient period is the time following any VID change, including entrance and exit of deeper sleep mode. The duration of VID transient period is the same as that of PWRGD masking time.
2. DNC = Do Not Care.
3. CCM = Continuous Conduction Mode.
4. DCM = Discontinuous Conduction Mode.

Switch Frequency Setting

Master Clock Frequency for PWM Mode

The clock frequency of the ADP3207C is set by an external resistor connected from the RT pin to ground. The frequency varies with the VID voltage; the lower the VID voltage, the lower the clock frequency. The variation of clock frequency with VID voltage makes VCore ripple remain constant and improves power conversion efficiency at a lower VID voltage.

To determine the switching frequency per phase, the clock is divided by the number of phases in use. If PWM3 is pulled up to VCC, then the master clock is divided by 2 for the frequency of the remaining phases. If PWM2 and PWM3 are pulled up to VCC, then the switching frequency of a Phase 1 equals the master clock frequency. If all phases are in use, divide by 3.

Switching Frequency for RPM Mode–Phase 1

When ADP3207C operates in single–phase RPM mode, its switching frequency is not controlled by the master clock, but by the ripple voltage on the COMP pin. The PWM1 pin is set high each time the COMP pin voltage rises to a voltage limit determined by the VID voltage and the external resistance connected between Pin RPM and ground. Whenever PWM1 pin is high, an internal ramp signal rises at a slew rate programmed by the current flowing into the RAMP pin. Once this internal ramp signal hits the COMP pin voltage, the PWM1 pin is reset to low.

In continuous current mode, the switching frequency of RPM operation is maintained almost constantly. While in discontinuous current mode, the switching frequency reduces with the load current.

Output Voltage Differential Sensing

The ADP3207C combines differential sensing with a high accuracy, VID DAC, precision REF output and a low offset error amplifier to meet the rigorous accuracy requirement of the Intel IMVP–6 specification. In steady–state, the VID DAC and error amplifier meet the worst–case error specification of ± 10 mV over the full operating output voltage and temperature range.

The CPU core output voltage is sensed between the FB pin and the FBRTN pin. Connect FB through a resistor to the positive regulation point, usually the VCC remote sense pin of the microprocessor. Connect FBRTN directly to the negative remote sense point, the VSS sense point of the CPU. The internal VID DAC and precision voltage reference are referenced to FBRTN and have a maximum current of 200 μ A to guarantee accurate remote sensing.

Output Current Sensing

The ADP3207C provides a dedicated current sense amplifier (CSA) to monitor the total output current of the converter for proper voltage positioning vs. load current and for current limit detection. Sensing the load current being delivered to the load is inherently more accurate than detecting peak current or sampling the current across a sense element, such as the low–side MOSFET. The current sense amplifier can be configured several ways depending on system requirements, including:

- Output inductor ESR sensing without use of a thermistor for lowest cost
- Output inductor ESR sensing with use of a thermistor that tracks inductor temperature to improve accuracy
- Discrete resistor sensing for highest accuracy

The positive input of the CSA is connected to the CSREF pin, which is connected to the output voltage. At the negative input CSSUM pin of the CSA, signals from the sensing element (that is, in case of inductor RDC sensing, signals from the switch node side of the output inductors) are summed together by using series summing resistors. The feedback resistor between CSCOMP and CSSUM sets the gain of the current sense amplifier, and a filter capacitor is placed in parallel with this resistor. The current information is then given as the voltage difference between CSREF and CSCOMP. This signal is used internally as a differential input for the current limit comparator.

An additional resistor divider connected between CSREF and CSCOMP with the midpoint connected to LLSET can be used to set the load line required by the microprocessor specification. The current information for load line setting is

then given as the voltage difference of CSREF – LLSET. The configuration in the previous paragraph makes it possible for the load line slope to be set independent of the current limit threshold. In the event that the current limit threshold and load line do not have to be independent, the resistor divider between CSREF and CSCOMP can be omitted and the CSCOMP pin can be connected directly to LLSET. To disable voltage positioning entirely (that is, to set no load line), tie LLSET to CSREF.

To provide the best accuracy for current sensing, the CSA is designed to have a low offset input voltage. In addition, the sensing gain is set by an external resistor ratio.

Active Impedance Control Mode

To control the dynamic output voltage droop as a function of the output current, the signal proportional to the total output current is converted to a voltage that appears between CSREF and LLINE. This voltage can be scaled to equal the droop voltage, which is calculated by multiplying the droop impedance of the regulator with the output current. The droop voltage is then used as the control voltage of the PWM regulator. The droop voltage is subtracted from the DAC reference output voltage and determines the voltage positioning setpoint. The setup results in an enhanced feed forward response.

Current Control Mode and Thermal Balance

The ADP3207C has individual inputs for monitoring the current in each phase. The phase current information is combined with an internal ramp to create a current balancing feedback system that is optimized for initial current accuracy and dynamic thermal balance. The current balance information is independent of the total inductor current information used for voltage positioning described in the Active Impedance Control Mode section.

The magnitude of the internal ramp can be set so the transient response of the system becomes optimal. The ADP3207C also monitors the supply voltage to achieve feed-forward control whenever the supply voltage changes. A resistor connected from the power input voltage rail to the RAMP pin determines the slope of the internal PWM ramp. Detailed information about programming the ramp is given in the Ramp Resistor Selection section.

External resistors are in series with the SW1 pin, SW2 pin, and the SW3 pin to create an intentional current imbalance. Such a condition can exist when one phase has better cooling and supports higher currents than the other phase. Resistor RSW2 and Resistor RSW3 (see the Typical Application Circuit in Figure 28) can be used to adjust thermal balance. It is recommended to add these resistors during the initial design to make sure placeholders are provided in the layout.

To increase the current in any given phase, users should make RSW for that phase larger (that is, make $RSW = 1.5 \text{ k}\Omega$ for the hottest phase and do not change it during balance optimization). Increasing RSW to $1.5 \text{ k}\Omega$ makes a substantial increase in phase current. Increase each RSW value by small

amounts to achieve thermal balance starting with the coolest phase.

If adjusting current balance between phases is not needed, RSW should be $1 \text{ k}\Omega$ for all phases.

Voltage Control Mode

A high gain bandwidth error amplifier is used for the voltage-mode control loop. The non-inverting input voltage is set via the 7-bit VID DAC. The VID codes are listed in Table 3. The non-inverting input voltage is offset by the droop voltage as a function of current, commonly known as active voltage positioning. The output of the error amplifier is the COMP pin, which sets the termination voltage for the internal PWM ramps.

The negative input, FB, is tied to the output sense location through a resistor, RB, for sensing and controlling the output voltage at the remote sense point. The main loop compensation is incorporated in the feedback network connected between FB and COMP.

Enhanced PWM Mode

Enhanced PWM mode is intended to improve the transient response to a load step up. In traditional PWM controllers, when a load step up occurred, the controller had to wait until the next turn on of the PWM signal to respond to the load change. Enhanced PWM mode allows the controller to respond immediately when a load step up occurs. This allows the phases to respond when the load increase transition takes place. EWPM is disabled in RPM operation.

Power-Good Monitoring

The power-good comparator monitors the output voltage via the CSREF pin. The PWRGD pin is an open drain output that can be pulled up through an external resistor to a voltage rail that is not necessarily the same V_{CC} voltage rail of the controller. Logic high level indicates that the output voltage is within the voltage limits defined by a window around the VID voltage setting. PWRGD goes low when the output voltage is outside of that window.

Following the IMVP-6 specification, the PWRGD window is defined as -300 mV below and $+200 \text{ mV}$ above the actual VID DAC output voltage. For any DAC voltage below 300 mV , only the upper limit of the PWRGD window is monitored. To prevent false alarm, the power-good circuit is masked during various system transitions, including any VID change and entrance/exit out of deeper sleep. The duration of the PWRGD mask is set by an internal timer to be about $100 \mu\text{s}$. In conditions where a larger than 200 mV voltage drop occurs during deeper sleep entry or slow deeper sleep exit, the duration of PWRGD masking is extended by an internal logic circuit.

Powerup Sequence and Soft-Start

The power-on, ramp-up time of the output voltage is set internally. The reference voltage of the voltage error amplifier is connected to an internal DAC. This DAC converts the VID

code to an analog reference voltage. During startup, the DAC ignores the VID code. The internal DAC steps through each VID code from 0 V to the boot voltage. The DAC steps to the next VID code every 16 μ s. With 12.5 mV difference between VID codes, the soft-start slew rate is 12.5 mV / 16 μ s or approximately 0.78 mV/ μ s. This gives a soft-start time of approximately 1.5 ms.

After the DAC reaches the boot voltage, an internal 100 μ s timer starts. This is the 100 μ s boot time. After the boot time is over, the $\overline{\text{CLKEN}}$ is asserted low. The DAC then reads the VID code. There is a soft transition from the boot voltage to the VID voltage. After $\overline{\text{CLKEN}}$ is asserted low, there is an internal 8 ms timer that asserts PWRGD high. The whole powerup sequence, including soft-start, is illustrated in Figure 26.

In V_{CC} UVLO or in shutdown, PWM1, PWM2, and PWM3 are pulled low. When V_{CC} ramps above the upper UVLO threshold and EN is asserted high, the ADP3207C enables internal bias and starts a reset cycle that lasts about 50 μ s to 60 μ s. Next, when initial reset is over, the chip detects the number of phases set by the user and gives a go signal to start the internal soft-start. After the $\overline{\text{CLKEN}}$ is asserted low, the ADP3207C reads the VID codes provided by the CPU on VID0 to VID6 input pins. The V_{Core} voltage changes from V_{BOOT} to the VID voltage by a well-controlled soft transition, as introduced in the Soft Transient section.

The PWRGD signal is not asserted until there is a $t_{\text{CPU_PWRGD}}$ delay of approximately 8 ms, which is fixed internally by the ADP3207C.

If either EN is taken low or V_{CC} drops below the lower V_{CC} UVLO threshold, the PWM1, PWM2, and PWM3 signals stop switching. An internal MOSFET discharges the output voltage through the CSREF pin. The internal CSREF MOSFET has a resistance of approximately 100 Ω .

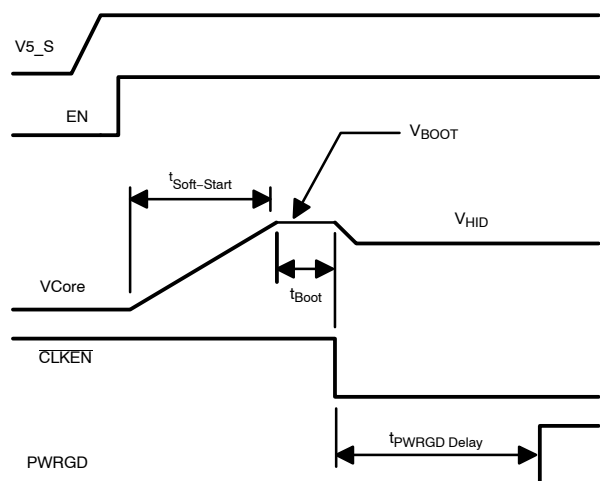

Figure 26. Powerup Sequence

Soft Transient

The ADP3207C provides a soft transient function to reduce inrush current during various transitions, including the entrance/exit of deeper sleep and the transition from V_{BOOT} to VID voltage. Reducing the inrush current helps

decrease the acoustic noise generated by the MLCC input capacitors and inductors.

The soft transient feature is implemented internally. When the ADP3207C detects a new VID code, the DAC steps through each VID code until it reaches the final code. For a fast slew rate, the ADP3207C steps to the next VID code every 1 μ s. This gives a fast slew rate of 12.5 mV/ μ s. For a slow slew rate, the ADP3207C steps to the next VID code every 4 μ s. This gives a slew rate of 3.125 mV/ μ s.

With DPRSLP asserted high, the slow slew rate is enabled. With DPRSLP asserted low, the fast slew rate is enabled. Table 2 summarizes the soft transient slew rate.

Table 2. Soft Transient Slew Rate

VID Transient	DPRSLP	Slew Rate
Fast Exit from Deeper Sleep	LOW	+12.5 mV/ μ s
Slow Exit from Deeper Sleep	HIGH	+3.125 mV/ μ s
Transient from V_{BOOT} to VID	DNC (Note 1)	± 3.125 mV/ μ s

1. DNC = Do Not Care.

Current Limit

The ADP3207C compares the differential output of a current sense amplifier to a programmable current limit setpoint to provide current limiting function. The current limit set point is set with a resistor connected from I_{LIM} pin to CSREF pin. This is the R_{lim} resistor. During normal operation, the voltage on the I_{LIM} pin is equal to the CSREF pin. The voltage across R_{lim} is equal to the voltage across the current sense amplifier (from CSREF pin to CSCOMP pin). This voltage is proportional to output current. The current through R_{lim} is proportional to the output inductor current. The current through R_{lim} is compared with an internal reference current. When the R_{lim} current goes above the internal reference current, the ADP3207C goes into current limit. The current limit circuit is shown in Figure 11.

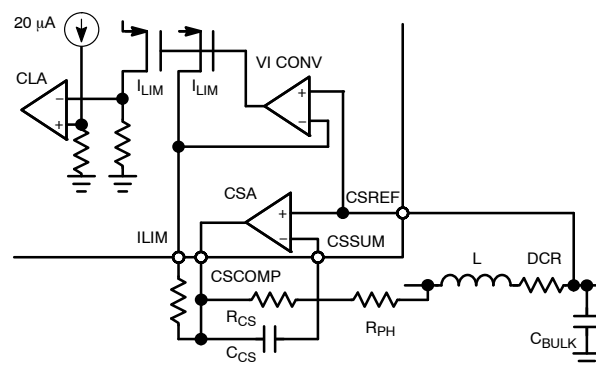

Figure 27. Current Limit Circuit

During startup when the output voltage is below 200 mV, a secondary current limit is activated. This is necessary because the voltage swing on CSCOMP cannot extend below ground. The secondary current limit circuit clamps the internal COMP voltage and sets the internal compensation ramp termination voltage at 1.5 V level. The clamp actually limits voltage drop across the low side MOSFETs through the current balance circuitry.

An inherent per phase current limit protects individual phases in case one or more phases stop functioning because of a faulty component. This limit is based on the maximum normal-mode COMP voltage.

After 9 ms in current limit, the ADP3207C will latchoff. The latchoff can be reset by removing and reapplying V_{CC} , or by recycling the EN pin low and high for a short time.

The latchoff can be reset by removing and reapplying V_{CC} , or by recycling the EN pin low and high for a short time.

Changing VID OTF

The ADP3207C is designed to track dynamically changing VID code. As a result, the converter output voltage, that is, the CPU V_{CC} voltage, can change without the need to reset either the controller or the CPU. This concept is commonly referred to as VID OTF transient. A VID OTF can occur either under light load or heavy load conditions. The processor signals the controller by changing the VID inputs in LSB incremental steps from the start code to the finish code. The change can be either upwards or downwards steps.

When a VID input changes state, the ADP3207C detects the change but ignores the new code for a minimum of 400 ns. This keep out is required to prevent reaction to false code that can occur by a skew in the VID code while the 7-bit VID input code is in transition. Additionally, the VID change triggers a PWRGD masking timer to prevent a PWRGD failure. Each VID change resets and retriggers the internal PWRGD masking timer. As listed in Table 2, during any VID transient, the ADP3207C forces a multi-phase PWM mode regardless of system input signals.

Output Crowbar

To protect the CPU load and output components of the converter, the PWM outputs are driven low, and \overline{DCM} and \overline{OD} are driven high (that is, commanded to turn on the low-side MOSFETs of all phases) when the output voltage exceeds an OVP threshold of 1.7 V as specified by IMVP-6.

Turning on the low-side MOSFETs discharges the output capacitor as soon as reverse current builds up in the inductors. If the output overvoltage is due to a short of the high-side MOSFET, then this crowbar action current limits the input supply or causes the input rail fuse to blow, protecting the microprocessor from destruction.

Once Overvoltage Protection (OVP) is triggered, the ADP3207C is latched off. The latchoff function can be reset by removing and reapplying V_{CC} , or by recycling EN low and high for a short time. OVP can be disabled by grounding the TTSENSE pin. The OVP comparator monitors the output voltage via the CSREF pin.

Reverse Voltage Protection

Very large reverse currents in inductors can cause negative V_{Core} voltage, which is harmful to the CPU and other output components. ADP3207C provides Reverse Voltage Protection (RVP) function without additional system cost. The V_{Core} voltage is monitored through the

CSREF pin. Any time the CSREF pin voltage is below -300 mV, the ADP3207C triggers its RVP function by disabling all PWM outputs and setting both the \overline{DCM} and \overline{OD} pins low. Thus, all the MOSFETs are turned off. The reverse inductor current can be quickly reset to 0 by dumping the energy built up in the inductor into the input dc voltage source via the forward biased body diode of the high-side MOSFETs. The RVP function is terminated when the CSREF pin voltage returns above -100 mV.

Occasionally, overvoltage crowbar protection results in negative V_{Core} voltage, because turn-on of all low-side MOSFETs leads to very large reverse inductor current. To prevent damage of the CPU by negative voltage, ADP3207C keeps its RVP monitoring function alive even after OVP latchoff. During OVP latchoff, if the CSREF pin voltage drops below -300 mV, then all low-side MOSFETs are turned off by setting both \overline{DCM} and \overline{OD} low. The \overline{DCM} pin and the \overline{OD} pin are set high again when CSREF voltage recovers above -100 mV.

Output Enable and UVLO

The V_{CC} supply voltage to the controller must be higher than the UVLO upper threshold, and the EN pin must be higher than its logic threshold so the ADP3207C can begin switching. If the V_{CC} voltage is less than the UVLO threshold, or the EN pin is logic low, then the ADP3207C is in shutdown. In shutdown, the controller holds the PWM outputs at ground, shorts the SS pin capacitor to ground, and drives \overline{DCM} and \overline{OD} pins low.

Proper power supply sequencing during startup and shutdown of the ADP3207C must be adhered to. All input pins must be at ground prior to applying or removing V_{CC} . All output pins should be left in high impedance state while V_{CC} is off.

Thermal Throttling Control

The ADP3207C includes a thermal monitoring circuit to detect if the temperature of the variable resistor (VR) has exceeded a user-defined thermal throttling threshold. The thermal monitoring circuit requires an external resistor divider connected between the V_{CC} pin and GND. The divider consists of an NTC thermistor and a resistor. To generate a voltage that is proportional to temperature, the midpoint of the divider is connected to the TTSENSE pin. Whenever the temperature trips the set alarm threshold, an internal comparator circuit compares the TTSENSE voltage to a half V_{CC} threshold and outputs a logic level signal at the VRTT output. The VRTT output is designed to drive an external transistor that, in turn, provides the high current, open drain \overline{VRTT} signal that is required by the IMVP-6 specification. When the temperature is around the set alarm point, the internal VRTT comparator has a hysteresis of about 100 mV to prevent high frequency oscillation of VRTT. The TTSENSE pin also serves the function of disabling OVP. In extreme heat, users should make sure that the TTSENSE pin voltage remains above 1.0 V if OVP is desired.

ADP3207C

Current Monitor Output

The ADP3207C has an output current monitor. The I_{MON} pin sources a current proportional to the inductor current. A

resistor from I_{MON} pin to FBRTN sets the gain. A 0.1 μF is added in parallel with R_{MON} to filter the inductor ripple. The I_{MON} pin is clamped to prevent it from going above 1.15 V

Table 3. VID Code Table

VID6	VID5	VID4	VID3	VID2	VID1	VID0	Output (V)
0	0	0	0	0	0	0	1.5000
0	0	0	0	0	0	1	1.4875
0	0	0	0	0	1	0	1.4750
0	0	0	0	0	1	1	1.4625
0	0	0	0	1	0	0	1.4500
0	0	0	0	1	0	1	1.4375
0	0	0	0	1	1	0	1.4250
0	0	0	0	1	1	1	1.4125
0	0	0	1	0	0	0	1.4000
0	0	0	1	0	0	1	1.3875
0	0	0	1	0	1	0	1.3750
0	0	0	1	0	1	1	1.3625
0	0	0	1	1	0	0	1.3500
0	0	0	1	1	0	1	1.3375
0	0	0	1	1	1	0	1.3250
0	0	0	1	1	1	1	1.3125
0	0	1	0	0	0	0	1.3000
0	0	1	0	0	0	1	1.2875
0	0	1	0	0	1	0	1.2750
0	0	1	0	0	1	1	1.2625
0	0	1	0	1	0	0	1.2500
0	0	1	0	1	0	1	1.2375
0	0	1	0	1	1	0	1.2250
0	0	1	0	1	1	1	1.2125
0	0	1	1	0	0	0	1.2000
0	0	1	1	0	0	1	1.1875
0	0	1	1	0	1	0	1.1750
0	0	1	1	0	1	1	1.1625
0	0	1	1	1	0	0	1.1500
0	0	1	1	1	0	1	1.1375
0	0	1	1	1	1	0	1.1250
0	0	1	1	1	1	1	1.1125
0	1	0	0	0	0	0	1.1000
0	1	0	0	0	0	1	1.0875
0	1	0	0	0	1	0	1.0750
0	1	0	0	0	1	1	1.0625
0	1	0	0	1	0	0	1.0500
0	1	0	0	1	0	1	1.0375
0	1	0	0	1	1	0	1.0250
0	1	0	0	1	1	1	1.0125
0	1	0	1	0	0	0	1.0000
0	1	0	1	0	0	1	0.9875
0	1	0	1	0	1	0	0.9750
0	1	0	1	0	1	1	0.9625

ADP3207C

Table 3. VID Code Table

VID6	VID5	VID4	VID3	VID2	VID1	VID0	Output (V)
0	1	0	1	1	0	0	0.9500
0	1	0	1	1	0	1	0.9375
0	1	0	1	1	1	0	0.9250
0	1	0	1	1	1	1	0.9125
0	1	1	0	0	0	0	0.9000
0	1	1	0	0	0	1	0.8875
0	1	1	0	0	1	0	0.8750
0	1	1	0	0	1	1	0.8625
0	1	1	0	1	0	0	0.8500
0	1	1	0	1	0	1	0.8375
0	1	1	0	1	1	0	0.8250
0	1	1	0	1	1	1	0.8125
0	1	1	1	0	0	0	0.8000
0	1	1	1	0	0	1	0.7875
0	1	1	1	0	1	0	0.7750
0	1	1	1	0	1	1	0.7625
0	1	1	1	1	0	0	0.7500
0	1	1	1	1	0	1	0.7375
0	1	1	1	1	1	0	0.7250
0	1	1	1	1	1	1	0.7125
1	0	0	0	0	0	0	0.7000
1	0	0	0	0	0	1	0.6875
1	0	0	0	0	1	0	0.6750
1	0	0	0	0	1	1	0.6625
1	0	0	0	1	0	0	0.6500
1	0	0	0	1	0	1	0.6375
1	0	0	0	1	1	0	0.6250
1	0	0	0	1	1	1	0.6125
1	0	0	1	0	0	0	0.6000
1	0	0	1	0	0	1	0.5875
1	0	0	1	0	1	0	0.5750
1	0	0	1	0	1	1	0.5625
1	0	0	1	1	0	0	0.5500
1	0	0	1	1	0	1	0.5375
1	0	0	1	1	1	0	0.5250
1	0	0	1	1	1	1	0.5125
1	0	1	0	0	0	0	0.5000
1	0	1	0	0	0	1	0.4875
1	0	1	0	0	1	0	0.4750
1	0	1	0	0	1	1	0.4625
1	0	1	0	1	0	0	0.4500
1	0	1	0	1	0	1	0.4375
1	0	1	0	1	1	0	0.4250
1	0	1	0	1	1	1	0.4125
1	0	1	1	0	0	0	0.4000
1	0	1	1	0	0	1	0.3875
1	0	1	1	0	1	0	0.3750

ADP3207C

Table 3. VID Code Table

VID6	VID5	VID4	VID3	VID2	VID1	VID0	Output (V)
1	0	1	1	0	1	1	0.3625
1	0	1	1	1	0	0	0.3500
1	0	1	1	1	0	1	0.3375
1	0	1	1	1	1	0	0.3250
1	0	1	1	1	1	1	0.3125
1	1	0	0	0	0	0	0.3000
1	1	0	0	0	0	1	0.2875
1	1	0	0	0	1	0	0.2750
1	1	0	0	0	1	1	0.2625
1	1	0	0	1	0	0	0.2500
1	1	0	0	1	0	1	0.2375
1	1	0	0	1	1	0	0.2250
1	1	0	0	1	1	1	0.2125
1	1	0	1	0	0	0	0.2000
1	1	0	1	0	0	1	0.1875
1	1	0	1	0	1	0	0.1750
1	1	0	1	0	1	1	0.1625
1	1	0	1	1	0	0	0.1500
1	1	0	1	1	0	1	0.1375
1	1	0	1	1	1	0	0.1250
1	1	0	1	1	1	1	0.1125
1	1	1	0	0	0	0	0.1000
1	1	1	0	0	0	1	0.0875
1	1	1	0	0	1	0	0.0750
1	1	1	0	0	1	1	0.0625
1	1	1	0	1	0	0	0.0500
1	1	1	0	1	0	1	0.0375
1	1	1	0	1	1	0	0.0250
1	1	1	0	1	1	1	0.0125
1	1	1	1	0	0	0	0.0000
1	1	1	1	0	0	1	0.0000
1	1	1	1	0	1	0	0.0000
1	1	1	1	0	1	1	0.0000
1	1	1	1	1	0	0	0.0000
1	1	1	1	1	0	1	0.0000
1	1	1	1	1	1	0	0.0000
1	1	1	1	1	1	1	0.0000

ADP3207C

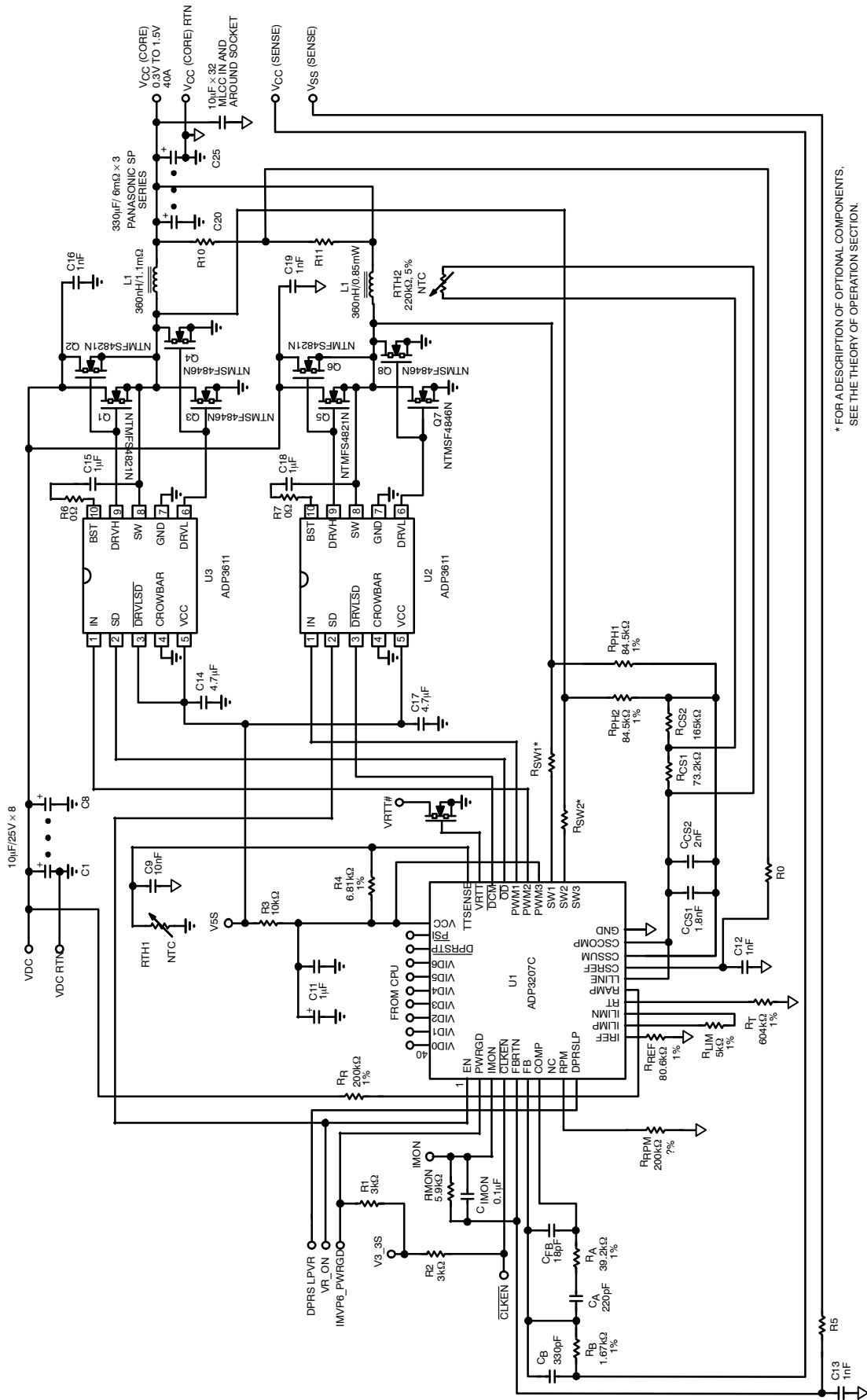

* FOR A DESCRIPTION OF OPTIONAL COMPONENTS, SEE THE THEORY OF OPERATION SECTION.

Figure 28. Typical 2-Phase Application Circuit

Application Information

The design parameters for a typical Intel IMVP6-compliant CPU core VR application are as follows:

- Maximum input voltage (V_{INMAX}) = 19 V
- Minimum input voltage (V_{INMIN}) = 7.0 V
- Output voltage by VID setting (V_{VID}) = 1.150 V
- Maximum output current (I_O) = 44 A
- Load line slope (R_O) = 2.1 m Ω
- Maximum output current step (ΔI_O) = 34.5 A
- Maximum output thermal current (I_{OTDC}) = 32 A
- Number of phases (n) = 2
- Switching frequency per phase (f_{SW}) = 280 kHz
- Duty cycle at maximum input voltage (D_{MIN}) = 0.061
- Duty cycle at minimum input voltage (D_{MAX}) = 0.164

Setting the Clock Frequency for PWM Mode

In PWM mode operation, the ADP3207C uses a fixed-frequency control architecture. The frequency is set by an external timing resistor (R_T). The clock frequency and the number of phases determine the switching frequency per phase, which directly relates to switching losses and the sizes of the inductors and input and output capacitors. In a 2-phase design, a clock frequency of 560 kHz sets the switching frequency to 280 kHz per phase. This selection represents a trade-off between the switching losses and the minimum sizes of the output filter components. To achieve a 560 kHz oscillator frequency at VID voltage 1.150 V, R_T has to be 237 k Ω . Alternatively, the value for R_T can be calculated using:

$$R_T = \frac{V_{VID} + 1.0 \text{ V}}{n \times f_{SW} \times 16 \text{ pF}} - 5 \text{ k}\Omega \quad (\text{eq. 1})$$

where 16 pF and 5 k Ω are internal IC component values. For good initial accuracy and frequency stability, it is recommended to use a 1% resistor.

Current Monitor Output

The I_{MON} pin output a current proportional to the inductor current.

Inductor Selection

The choice of inductance determines the ripple current in the inductor. Less inductance leads to more ripple current, which increases the output ripple voltage and conduction losses in the MOSFETs. However, this allows the use of smaller size inductors, and for a specified peak-to-peak transient deviation, it allows less total output capacitance. Conversely, a higher inductance means lower ripple current and reduced conduction losses but requires larger size inductors and more output capacitance for the same peak-to-peak transient deviation. In a multi-phase converter, the practical peak-to-peak inductor ripple current is less than 50% of the maximum dc current in the same inductor. Equation 2 shows the relationship between the inductance, oscillator frequency, and peak-to-peak ripple current.

Equation 3 can be used to determine the minimum inductance based on a given output ripple voltage.

$$I_R = \frac{V_{VID} \times (1 - D_{MIN})}{f_{SW} \times L} \quad (\text{eq. 2})$$

$$L \geq \frac{V_{VID} \times R_O \times (1 - (n \times D_{MIN})) \times (1 - D_{MIN})}{f_{SW} \times V_{RIPPLE}} \quad (\text{eq. 3})$$

Solving Equation 3 for a 20 mV peak-to-peak output ripple voltage yields:

$$L \geq \frac{1.150 \text{ V} \times 2.1 \text{ m}\Omega \times (1 - (2 \times 0.061)) \times (1 - 0.061)}{280 \text{ kHz} \times 20 \text{ mV}} = 356 \text{ nH} \quad (\text{eq. 4})$$

If the ripple voltage ends up being less than the initially selected value, then the inductor can be changed to a smaller value until the ripple value is met. This iteration allows optimal transient response and minimum output decoupling.

The smallest possible inductor should be used to minimize the number of output capacitors. For this example, choosing a 360 nH inductor is a good starting point and gives a calculated ripple current of 10.7 A. The inductor should not saturate at the peak current of 27.4 A and should be able to handle the sum of the power dissipation caused by the average current of 16 A in the winding and core loss.

Another important factor in the inductor design is the DCR, which is used to measure phase currents. A large DCR causes excessive power losses, though too small a value leads to increased measurement error. This example uses an inductor with a DCR of 0.89 m Ω .

Selecting a Standard Inductor

Once the inductance and DCR are known, the next step is to either design an inductor or select a standard inductor that comes as close as possible to meeting the overall design goals. It is also important to have the inductance and DCR tolerance specified to keep the accuracy of the system controlled; 20% inductance and 15% DCR (at room temperature) are reasonable expectations that most manufacturers can meet.

Power Inductor Manufacturers

The following companies provide surface mount power inductors optimized for high power applications upon request:

- Vishay Dale Electronics, Inc.
- Panasonic
- Sumida Corporation
- NEC Tokin Corporation

Output Droop Resistance

The inductor design requires that the regulator output voltage measured at the CPU pins drops when the output current increases. The specified voltage drop corresponds to a dc output resistance (R_O).

The output current is measured by summing the currents of the resistors monitoring the voltage across each inductor and

by passing the signal through a low-pass filter. This summer-filter is implemented by the CS amplifier that is configured with resistors $R_{PH(X)}$ (summer), and R_{CS} and C_{CS} (filter). The output resistance of the regulator is set by the following equations:

$$R_O = \frac{R_{CS}}{R_{PH(X)}} \times R_L \quad (\text{eq. 5})$$

$$C_{CS} = \frac{L}{R_L \cdot R_{CS}} \quad (\text{eq. 6})$$

where R_L is the DCR of the output inductors.

Users have the flexibility of choosing either R_{CS} or $R_{PH(X)}$. Due to the current drive ability of the CSCOMP pin, the R_{CS} resistance should be larger than 100 k Ω . For example, users should initially select R_{CS} to be equal to 220 k Ω , then use Equation 6 to solve for C_{CS} .

$$C_{CS} = \frac{360 \text{ nH}}{0.89 \text{ m}\Omega \times 220 \text{ k}\Omega} = 1.84 \text{ nF}$$

Because C_{CS} is not the standard capacitance, it is implemented with two standard capacitors in parallel: 1.8 nF and 47 pF. For the best accuracy, C_{CS} should be a 5% NPO capacitor. Next, solve $R_{PH(X)}$ by rearranging Equation 5.

$$R_{PH(X)} \geq \frac{0.89 \text{ m}\Omega}{2.1 \text{ m}\Omega} \cdot 220 \text{ k}\Omega = 93.2 \text{ k}\Omega$$

The standard 1% resistor for $R_{PH(X)}$ is 93.1 k Ω .

To prevent the saturation of the current sense amplifier when multiple phases turn on together, it is recommended to keep $R_{PH(X)} > 90 \text{ k}\Omega$ in the 2-phase application and $R_{PH(X)} > 133 \text{ k}\Omega$ in the 3-phase application.

To avoid high frequency noise coupling across the R_{PH} resistors, the size of the R_{PH} resistors should not be smaller than the 0603 size.

Inductor DCR Temperature Correction

With the inductor DCR used as a sense element, and copper wire being the source of the DCR, users need to compensate for temperature changes in the inductor's winding. Fortunately, copper has a well-known temperature coefficient (TC) of 0.39%/°C.

If R_{CS} is designed to have an opposite sign but equal percentage change in resistance, then it cancels the temperature variation of the inductor DCR. Due to the nonlinear nature of NTC thermistors, series resistors, R_{CS1} and R_{CS2} (see Figure 29) are needed to linearize the NTC and produce the desired TC tracking.

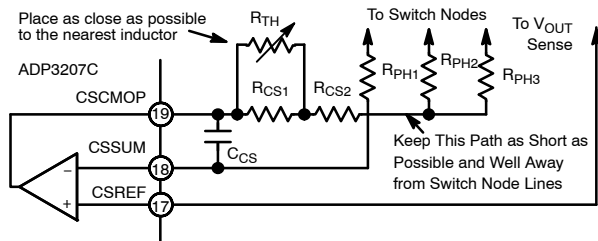

Figure 29. Temperature Compensation Circuit Values

The following procedure and equations yield values for R_{CS1} , R_{CS2} , and R_{TH} (the thermistor value at 25°C) for a given R_{CS} value:

1. Select an NTC to be used based on type and value. Because there is no value yet, start with a thermistor with a value close to R_{CS} . The NTC should also have an initial tolerance of better than 5%.
2. Based on the type of NTC, find its relative resistance value at two temperatures. Temperatures that work well are 50°C and 90°C. These are called Resistance Value A (A is $R_{TH}(50^\circ\text{C})/R_{TH}(25^\circ\text{C})$) and Resistance Value B (B is $R_{TH}(90^\circ\text{C})/R_{TH}(25^\circ\text{C})$). Note the relative value of NTC is always 1 at 25°C.
3. Next, find the relative value of R_{CS} that is required for each of these temperatures. This is based on the percentage of change needed, which is initially 0.39%/°C. These are called r_1 and r_2 .

$$r_1 = \frac{1}{1 + TC \cdot (T_1 - 25)} \quad (\text{eq. 7})$$

$$r_2 = \frac{1}{1 + TC \cdot (T_2 - 25)}$$

Where:

$$\begin{aligned} TC &= 0.0039 \\ T_1 &= 50^\circ\text{C} \\ T_2 &= 90^\circ\text{C} \end{aligned}$$

4. Compute the relative values for r_{CS1} , r_{CS2} , and r_{TH} using:

$$r_{CS2} = \frac{(A - B) \times r_1 \times r_2 - A \times (1 - B) \times r_2 + B \times (1 - A) \times r_1}{A \times (1 - B) \times r_1 - B \times (1 - A) \times r_2 - (A - B)}$$

$$r_{CS1} = \frac{(1 - A)}{\frac{1}{1 - r_{CS2}} - \frac{1}{r_1 - r_{CS2}}}$$

$$r_{TH} = \frac{1}{\frac{1}{1 - r_{CS2}} - \frac{1}{r_{CS1}}} \quad (\text{eq. 8})$$

5. Calculate $R_{TH} = R_{TH} \times R_{CS}$, then select the closest value of thermistor that is available. Also, compute a scaling factor k based on the ratio of the actual thermistor value relative to the computed one.

$$k = \frac{R_{TH(\text{ACTUAL})}}{R_{TH(\text{CALCULATED})}} \quad (\text{eq. 9})$$

6. Finally, calculate values for R_{CS1} and R_{CS2} using:

$$\begin{aligned} R_{CS1} &= R_{CS} \times k \times r_{CS1} \\ R_{CS2} &= R_{CS} \times ((1 - k) + (k \times r_{CS2})) \quad (\text{eq. 10}) \end{aligned}$$

This example starts with a thermistor value of 100 k Ω and uses a Vishay NTHS0603N04 NTC thermistor (a 0603 size thermistor) with A = 0.3359 and B = 0.0771. From this data, $r_{CS1} = 0.359$, $r_{CS2} = 0.729$, and $r_{TH} = 1.094$. Solving for R_{TH} yields 240 k Ω , so 220 k Ω is chosen, making k = 0.914. Finally, R_{CS1} and R_{CS2} are 72.3 k Ω and 166 k Ω . Choosing the closest 1% resistor values yields a choice of 71.5 k Ω and 165 k Ω .

C_{OUT} Selection

The required output decoupling for processors and platforms is typically recommended by Intel. The following guidelines can also be used if both bulk and ceramic capacitors are in the system:

- Select the total amount of ceramic capacitance. This is based on the number and type of capacitors to be used. The best location for ceramics is inside the socket; 20 pieces of Size 0805 being the physical limit. Additional capacitors can be placed along the outer edge of the socket.
- Select the number of ceramics and find the total ceramic capacitance (C_Z). Combined ceramic values of 200 μF to 300 μF are recommended and are usually made up of multiple 10 μF or 22 μF capacitors.
- Note that there is an upper limit imposed on the total amount of bulk capacitance (C_X) when considering the VID OTF output voltage stepping (voltage step V_V in time t_V with error of V_{ERR}), and also a lower limit based on meeting the critical capacitance for load release at a given maximum load step ΔI_O. For a step-off load current, the current version of the IMVP-6 specification allows a maximum VCore overshoot (V_{OSMAX}) of 10 mV, plus 1.5% of the VID voltage. For example, if the VID is 1.150 V, then the largest overshoot allowed is 50 mV.

$$C_{X(MIN)} \geq \left[\frac{L \times \Delta I_O}{n \times \left(R_O + \frac{V_{OSMAX}}{\Delta I_O} \right) \times V_{VVID}} - C_Z \right] \quad (\text{eq. 11})$$

$$C_{X(MAX)} \leq \frac{L}{nK^2 R_O^2} \times \frac{V_V}{V_{VVID}} \times \left[\sqrt{1 + \left(\frac{V_{VVID}}{t_V} \times \frac{nKR_O}{L} \right)^2} - 1 \right] - C_Z \quad (\text{eq. 12})$$

where:

$$K = -1n \left(\frac{V_{ERR}}{V_V} \right) \quad (\text{eq. 13})$$

To meet the conditions of these equations and transient response, the ESR of the bulk capacitor bank (R_X) should be less than two times the droop resistance, R_O. If the C_{X(MIN)} is larger than the C_{X(MAX)}, the system does not meet the VID OTF and/or deeper sleep exit specification and can require a smaller inductor or more phases (the switching frequency can also have to be increased to keep the output ripple the same).

For example, if using 32 pieces of 10 μF 0805 MLC capacitors (C_Z = 320 μF), the fastest VID voltage change is the exit of deeper sleep, and the VCore change is 220 mV in 22 μs with a setting error of 10 mV.

Where K = 3.1, solving for the bulk capacitance yields.

$$C_{X(MIN)} \geq \left[\frac{360 \text{ nH} \cdot 34.5 \text{ A}}{2 \cdot \left(2.1 \text{ m}\Omega + \frac{50 \text{ mV}}{34.5 \text{ A}} \right) \cdot 1.150 \text{ V}} - 320 \text{ }\mu\text{F} \right] = 0.8 \text{ mF}$$

$$C_{X(MAX)} \leq \frac{360 \text{ nH} \times 220 \text{ mV}}{2 \times 3.1^2 \times (2.1 \text{ m}\Omega)^2 \times 1.150 \text{ V}} \times \left[\sqrt{1 + \left(\frac{22 \text{ }\mu\text{s} \times 1.150 \text{ V} \times 2 \times 3.1 \times 2.1 \text{ m}\Omega}{220 \text{ mV} \times 360 \text{ nH}} \right)^2} - 1 \right] - 320 \text{ }\mu\text{F} = 2.3 \text{ mF}$$

Using three 330 μF Panasonic SP capacitors with a typical ESR of 6 mΩ each, yields C_X = 0.99 mF with an R_X = 2.0 mΩ.

One last check should be made to ensure that the ESL of the bulk capacitors (L_X) is low enough to limit the high frequency ringing during a load change. This is tested using:

$$L_X \leq C_2 \times R_O^2 \times Q^2$$

$$L_X \leq C_{320 \text{ }\mu\text{F}} \times (2.1 \text{ m}\Omega)^2 \times 2 = 2 \text{ nH} \quad (\text{eq. 14})$$

Where:

Q is limited to the √2 to ensure a critically damped system.

In this example, L_X is about 330 pH for the three SP capacitors, which satisfies this limitation. If the L_X of the chosen bulk capacitor bank is too large, the number of ceramic capacitors may need to be increased if there is excessive ringing.

Note that for this multi-mode control technique, an all-ceramic capacitor design can be used as long as the conditions of Equations 11, 12, and 13 are satisfied.

Power MOSFETs

For normal 20 A per phase application, the N-channel power MOSFETs are selected for two high-side switches and two low-side switches per phase. The main selection parameters for the power MOSFETs are V_{GS(TH)}, Q_G, C_{ISS}, C_{RSS}, and R_{DS(ON)}. Because the gate drive voltage (the supply voltage to the ADP3611) is 5.0 V, logic-level threshold MOSFETs must be used.

The maximum output current I_O determines the R_{DS(on)} requirement for the low-side (synchronous) MOSFETs. In the ADP3207C, currents are balanced between phases; the current in each low-side MOSFET is the output current divided by the total number of MOSFETs (n_{SF}). With conduction losses being dominant, Equation 15 shows the total power dissipated in each synchronous MOSFET in terms of the ripple current per phase (I_R) and average total output current (I_O):

$$P_{SF} = (1 - D) \times \left[\left(\frac{I_O}{n_{SF}} \right) + \frac{1}{12} \times \left(\frac{n \times I_R}{n_{SF}} \right)^2 \right] \times R_{DS(SF)} \quad (\text{eq. 15})$$

Knowing the maximum output thermal current and the maximum allowed power dissipation, users can find the required $R_{DS(on)}$ for the MOSFET. For 8-lead SOIC or 8-lead SOIC-compatible packaged MOSFETs the junction to ambient (PCB) thermal impedance is $50^{\circ}\text{C}/\text{W}$. In the worst case, the PCB temperature is 90°C during heavy load operation of the notebook; a safe limit for P_{SF} is 0.6 W at 120°C junction temperature. Therefore, for this example (32 A maximum thermal current), $R_{DS(SF)}$ (per MOSFET) is less than $9.6\text{ m}\Omega$ for two pieces of low-side MOSFET. This $R_{DS(SF)}$ is also at a junction temperature of about 120°C ; therefore, the $R_{DS(SF)}$ (per MOSFET) should be lower than $6.8\text{ m}\Omega$ at room temperature, giving $9.6\text{ m}\Omega$ at high temperature.

Another important factor for the synchronous MOSFET is the input capacitance and feedback capacitance. The ratio of feedback to input needs to be small (less than 10% is recommended) to prevent accidental turn-on of the synchronous MOSFETs when the switch node goes high.

The high-side (main) MOSFET has to be able to handle two main power dissipation components, conduction and switching losses. The switching loss is related to the amount of time it takes for the main MOSFET to turn on and off and to the current and voltage that are being switched. Basing the switching speed on the rise and fall time of the gate driver impedance and MOSFET input capacitance, Equation 16 provides an approximate value for the switching loss per main MOSFETs.

$$P_{S(MF)} = 2 \times f_{SW} \times \frac{V_{CC} \times I_O}{n_{MF}} \times R_G \times \frac{n_{MF}}{n} \times C_{ISS} \quad (\text{eq. 16})$$

Where:

n_{MF} is the total number of main MOSFETs. R_G is the total gate resistance ($1.5\ \Omega$ for the ADP3611 and about $0.5\ \Omega$ for two pieces of typical high speed switching MOSFETs, making $R_G = 2\ \Omega$). C_{ISS} is the input capacitance of the main MOSFET. The best thing to reduce switching loss is to use lower gate capacitance devices.

The conduction loss of the main MOSFET is given by:

$$P_{C(MF)} = D \times \left[\left(\frac{I_O}{n_{MF}} \right)^2 + \frac{1}{12} \times \left(\frac{n \times I_R}{n_{MF}} \right)^2 \right] \times R_{DS(MF)} \quad (\text{eq. 17})$$

Where: $R_{DS(MF)}$ is the on-resistance of the MOSFET.

Typically, for main MOSFETs, users want the highest speed (low C_{ISS}) device, but these usually have higher on-resistance. Users must select a device that meets the total power dissipation (0.6 W for a single 8-lead SOIC) when combining the switching and conduction losses.

For example, using an IRF7821 device as the main MOSFET (four in total; that is, $n_{MF} = 4$), with about $C_{ISS} = 1010\text{ pF}$ (maximum) and $R_{DS(MF)} = 18\text{ m}\Omega$ (maximum at $T_J = 120^{\circ}\text{C}$) and an IR7832 device as the synchronous MOSFET (four in total; that is, $n_{SF} = 4$), $R_{DS(SF)} = 6.7\text{ m}\Omega$ (maximum at $T_J = 120^{\circ}\text{C}$). Solving for the power dissipation per MOSFET at $I_O = 32\text{ A}$ and $I_R = 10.7\text{ A}$

yields 420 mW for each synchronous MOSFET and 410 mW for each main MOSFET.

One last consideration is the power dissipation in the driver for each phase. This is best described in terms of the QG for the MOSFETs and is given by:

$$P_{DRV} = \left[\frac{f_{SW}}{2 \times n} \times (n_{MF} \times Q_{GMF} + n_{SF} \times Q_{GSF}) + I_{CC} \right] \times V_{CC} \quad (\text{eq. 18})$$

Where:

Q_{GMF} is the total gate charge for each main MOSFET.

Q_{GSF} is the total gate charge for each synchronous MOSFET.

This also shows the standby dissipation ($I_{CC} \times V_{CC}$) of the driver. For the ADP3611, the maximum dissipation should be less than 300 mW , considering its thermal impedance is $220^{\circ}\text{C}/\text{W}$, and the maximum temperature increase is 50°C . For this example, with $I_{CC} = 2\text{ mA}$, $Q_{GMF} = 14\text{ nC}$, and $Q_{GSF} = 51\text{ nC}$, there is 120 mW dissipation in each driver, which is below the 300 mW dissipation limit. Refer to data sheet ADP3611 for more details.

Ramp Resistor Selection

The ramp resistor (R_R) is used for setting the size of the internal PWM ramp. The value of this resistor is chosen to provide the best combination of thermal balance, stability, and transient response. Use this equation to determine a starting value:

$$R_R = \frac{A_R \times L}{3 \times A_D \times R_{DS} \times C_R} \quad (\text{eq. 19})$$

$$R_R = \frac{0.5 \times 360\text{ nH}}{3 \times 5 \times 5.2\text{ m}\Omega \times 5\text{ pF}} = 462\text{ k}\Omega$$

Where:

A_R is the internal ramp amplifier gain.

A_D is the current balancing amplifier gain.

R_{DS} is the total low-side MOSFET on-resistance,

C_R is the internal ramp capacitor value.

Another consideration in the selection of R_R is the size of the internal ramp voltage (see Equation 20). For stability and noise immunity, keep this ramp size larger than 0.5 V . In addition, larger ramp size helps to reduce output voltage ringing back during step load transient, where EPWM is triggered. Taking these into consideration, the value of R_R is selected as $200\text{ k}\Omega$.

The internal ramp voltage magnitude can be calculated by:

$$V_R = \frac{A_R \times (1 - D) \times V_{VID}}{R_R \times C_R \times f_{SW}} \quad (\text{eq. 20})$$

$$V_R = \frac{0.2 \times (1 - 0.061) \times 1.150\text{ V}}{200\text{ k}\Omega \times 5\text{ pF} \times 280\text{ kHz}} = 0.77\text{ V}$$

The size of the internal ramp can be made larger or smaller. If it is made larger, then stability and transient response improves, but thermal balance degrades. Likewise, if the ramp is made smaller, then thermal balance improves at the sacrifice of transient response and stability. The factor of three in the denominator of Equation 19 sets a minimum

ramp size that gives an optimal balance for good stability, transient response, and thermal balance.

COMP Pin Ramp

There is a ramp signal on the COMP pin due to the droop voltage and output voltage ramps. This ramp amplitude adds to the internal ramp to produce the following overall ramp signal at the PWM input:

$$V_{RT} = \frac{V_R}{\left(1 - \frac{2 \times (1 - n \times D)}{n \times f_{SW} \times C_X \times R_O}\right)} \quad (\text{eq. 21})$$

For this example, the overall ramp signal is found to be 2.2 V.

Setting the Switching Frequency for RPM Mode Operation of Phase.

During the RPM mode operation of Phase 1, the ADP3207C runs in pseudo constant frequency, given that the load current is high enough for continuous current mode. While in discontinuous current mode, the switching frequency is reduced with the load current in a linear manner. When considering power conversion efficiency in light load, lower switching frequency is usually preferred for RPM mode. However, the VCore ripple specification in the IMVP-6 sets the limitation for lowest switching frequency. Therefore, depending on the inductor and output capacitors, the switching frequency in RPM mode can be equal, larger, or smaller than its counterpart in PWM mode.

A resistor from RPM to GND sets the pseudo constant frequency as following:

$$R_{RPM} = \frac{2 \times R_T}{V_{VID} + 1.0 \text{ V}} \times \frac{A_R \times (1 - D) \times V_{VID}}{R_R \times C_R \times f_{SW}} - 0.5 \text{ k}\Omega \quad (\text{eq. 22})$$

Where:

A_R is the internal ramp amplifier gain.

C_R is the internal ramp capacitor value.

R_R is an external resistor on the RAMPADJ pin to set the internal ramp magnitude.

Because $R_R = 280 \text{ k}\Omega$, the following resistance sets up 300 kHz switching frequency in RPM operation:

$$R_{RPM} = \frac{2 \times 280 \text{ k}\Omega}{1.150 \text{ V} + 1.0 \text{ V}} \times \frac{0.5 \times (1 - 0.061) \times 1.150}{462 \text{ k}\Omega \times 5 \text{ pF} \times 300 \text{ kHz}} - 5 \Omega = 202 \text{ k}\Omega \quad (\text{eq. 23})$$

Output Current Monitor

The ADP3207C has output current monitor. The I_{MON} pin sources a current proportional to the total inductor current. A resistor, R_{MON} , from I_{MON} to FBRTN sets the gain of the output current monitor. A 0.1 μF is placed in parallel with R_{MON} to filter the inductor current ripple and high frequency load transients. Since the I_{MON} pin is connected directly to the CPU, it is clamped to prevent it from going above 1.15 V.

The I_{MON} pin current is equal to the R_{LIM} times a fixed gain of 10. R_{MON} can be found using the following equation:

$$R_{MON} = \frac{1.15 \text{ V} \times R_{LIM}}{10 \times R_O \times I_{FS}} \quad (\text{eq. 24})$$

Where:

R_{MON} is the current monitor resistor. R_{MON} is connected from I_{MON} pin to FBRTN.

R_{LIM} is the current limit resistor.

R_O is the output load line resistance.

I_{FS} is the output current when the voltage on I_{MON} is at full scale.

Current Limit Setpoint

To select the current limit setpoint, we need to find the resistor value for R_{LIM} . The current limit threshold for the ADP3207C is set when the current in R_{LIM} is equal to the internal reference current of 20 μA . The current in R_{LIM} is equal to the inductor current times R_O . R_{LIM} can be found using the following equation:

$$R_{LIM} = \frac{I_{LIM} \times R_O}{20 \mu\text{A}} \quad (\text{eq. 25})$$

Where:

R_{LIM} is the current limit resistor. R_{LIM} is connected from the I_{LIM} pin to ground.

R_O is the output load line resistance.

I_{LIM} is the current limit set point. This is the peak inductor current that will trip current limit.

In this example, if choosing 55 A for I_{LIM} , R_{LIM} is 5.775 k Ω , which is close to a standard 1% resistance of 5.76 k Ω .

The per phase current limit described earlier has its limit determined by the following:

$$I_{PHLIM} \cong \frac{V_{COMP(MAX)} - V_R - V_{BIAS}}{A_D \times R_{DS(MAX)}} + \frac{I_R}{2} \quad (\text{eq. 26})$$

For the ADP3207C, the maximum COMP voltage ($V_{COMP(MAX)}$) is 3.3 V, the COMP pin bias voltage (V_{BIAS}) is 1.0 V, and the current balancing amplifier gain (A_D) is 5. Using a V_R of 0.55 V, and a $R_{DS(MAX)}$ of 3.8 m Ω (low-side on-resistance at 150°C) results in a per phase limit of 85 A. Although this number seems high, this current level can only be reached with a absolute short at the output and the current limit latchoff function shutting down the regulator before overheating occurs.

This limit can be adjusted by changing the ramp voltage V_R . However, users should not set the per phase limit lower than the average per phase current (I_{LIM}/n).

There is also a per phase initial duty-cycle limit at maximum input voltage:

$$D_{LIM} = D_{MIN} \times \frac{V_{COMP(MAX)} - V_{BIAS}}{V_R} \quad (\text{eq. 27})$$

For this example, the duty-cycle limit at maximum input voltage is found to be 0.25 when D is 0.061.

Feedback Loop Compensation Design

Optimized compensation of the ADP3207C allows the best possible response of the regulator's output to a load change. The basis for determining the optimum compensation is to make the regulator and output decoupling appear as an output

impedance that is entirely resistive over the widest possible frequency range, including dc, and equal to the droop resistance (R_O). With the resistive output impedance, the output voltage droops in proportion with the load current at any load current slew rate. This ensures the optimal positioning and minimizes the output decoupling.

With the multi-mode feedback structure of the ADP3207C, users need to set the feedback compensation to make the converter output impedance work in parallel with the output decoupling. Several poles and zeros are created by the output inductor and decoupling capacitors (output filter) that need to be compensated for.

A type-three compensator on the voltage feedback is adequate for proper compensation of the output filter. Equations 28 to 36 is intended to yield an optimal starting point for the design; some adjustments can be necessary to account for PCB and component parasitic effects (refer to the Tuning Procedure for ADP3207C section).

The first step is to compute the time constants for all of the poles and zeros in the system:

$$R_E = n \times R_O + A_D \times R_{DS} + \frac{R_L \times V_{RT}}{V_{ID}} + \frac{2 \times L \times (1 - n \times D) \times V_{RT}}{n \times C_X \times R_O \times V_{VID}} \quad (\text{eq. 28})$$

$$T_A = C_X \times (R_O - R') + \frac{L_X}{R_O} \times \frac{R_O - R'}{R_X} \quad (\text{eq. 29})$$

$$T_B = (R_X + R' - R_O) \times C_X \quad (\text{eq. 30})$$

$$T_C = \frac{V_{RT} \times \left(L - \frac{A_D \times R_{DS}}{2 \times f_{SW}} \right)}{V_{VID} \times R_E} \quad (\text{eq. 31})$$

$$T_D = \frac{C_X \times C_Z \times R_O^2}{C_X \times (R_O - R') + C_Z \times R_O} \quad (\text{eq. 32})$$

Where:

R' is the PCB resistance from the bulk capacitors to the ceramics. R_{DS} is the total low-side MOSFET on-resistance per phase.

For this example, A_D is 5, $V_{RT} = 1.5$ V, R' is approximately 0.4 m Ω (assuming an 8-layer motherboard), and L_X is 250 pH for the four Panasonic SP capacitors.

The compensation values can be solved using the following:

$$C_A = \frac{n \times R_O \times T_A}{R_E \times R_B} \quad (\text{eq. 33})$$

$$R_A = \frac{T_C}{C_A} \quad (\text{eq. 34})$$

$$C_B = \frac{T_B}{R_B} \quad (\text{eq. 35})$$

$$C_{FB} = \frac{T_D}{R_A} \quad (\text{eq. 36})$$

The standard values for these components are subject to the tuning procedure, as introduced in the C_{IN} Selection and Input Current D_I/D_T Reduction section.

C_{IN} Selection and Input Current D_I/D_T Reduction

In continuous inductor current mode, the source current of the high-side MOSFET is approximately a square wave with a duty ratio equal to $n \times V_{OUT}/V_{IN}$ and an amplitude of 1-nth the maximum output current. To prevent large voltage transients, a low ESR input capacitor sized for the maximum rms current must be used. The maximum rms capacitor current happens at the lowest input voltage, and is given by:

$$I_{CRMS} = D \times I_O \times \sqrt{\frac{1}{n \times D} - 1} \quad (\text{eq. 37})$$

$$I_{CRMS} = 0.164 \times 44 \text{ A} \times \sqrt{\frac{1}{2 \times 0.164} - 1} = 10.3 \text{ A}$$

In a typical notebook system, the battery rail decouplings are MLCC capacitors or a mixture of MLCC capacitors and bulk capacitors. In this example, the input capacitor bank is formed by eight pieces of 10 μ F, and 25 V MLCC capacitors with a ripple current rating of about 1.5 A each.

RC Snubber

It is important in any buck topology to use a resistor capacitor snubber across the low side power MOSFET. The RC snubber dampens ringing on the switch node when the high side MOSFET turns on. The switch node ringing could cause EMI system failures and increased stress on the power components and controller. The RC snubber should be placed as close as possible to the low side MOSFET. Typical values for the resistor range from 1 Ω to 10 Ω . Typical values for the capacitor range from 330 pF to 4.7 nF. The exact value of the RC snubber depends on the PCB layout and MOSFET selection. Some fine tuning must be done to find the best values. The equation below is used to find the starting values for the RC snubber.

$$R_{Snubber} = \frac{1}{2 \times \pi \times f_{Ringing} \times C_{OSS}} \quad (\text{eq. 38})$$

$$C_{Snubber} = \frac{1}{\pi \times f_{Ringing} \times R_{Snubber}} \quad (\text{eq. 39})$$

$$P_{Snubber} = C_{Snubber} \times V_{Input}^2 \times f_{Switching} \quad (\text{eq. 40})$$

Where $R_{Snubber}$ is the snubber resistor.

$C_{Snubber}$ is the snubber capacitor.

$f_{Ringing}$ is the frequency of the ringing on the switch node when the high side MOSFET turns on.

C_{OSS} is the low side MOSFET output capacitance at V_{Input} . This is taken from the low side MOSFET data sheet.

V_{Input} is the input voltage.

$f_{Switching}$ is the switching frequency.

$P_{Snubber}$ is the power dissipated in $R_{Snubber}$.

Selecting Thermal Monitor Components

For single-point hot spot thermal monitoring, simply set R_{TTSET1} equal to the NTC thermistor's resistance at the alarm temperature (see Figure 30). For example, if the VR_{TT} alarm temperature is 100°C using a Vishay thermistor (NTHS-0603N011003J) with a resistance of 100 kΩ at 25°C, and 6.8 kΩ at 100°C, simply set $R_{TTSET1} = R_{TH1}$ (100°C) to 6.8 kΩ.

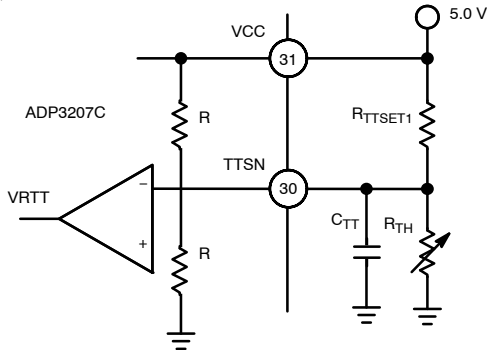

Figure 30. Single-Point Thermal Monitoring

Multiple-point hot spot thermal monitoring can be implemented as shown in Figure 31. If any of the monitored hot spots reach alarm temperature, the VR_{TT} signal is asserted. The following calculation sets the alarm temperature:

$$R_{TTSET1} = \frac{\frac{1}{2} + \frac{V_{FD}}{V_{REF}}}{\frac{1}{2} - \frac{V_{FD}}{V_{REF}}} R_{TH1ALARMTEMPERATURE} \quad (\text{eq. 41})$$

Where V_{FD} is the forward drop voltage of the parallel diode. Because the forward current is very small, the forward drop voltage is very low (100 mV). Assuming the same 100°C alarm temperature used in the single-spot thermal monitoring example, and the same Vishay thermistor, then Equation 41 leads to $R_{TTSET} = 7.37 \text{ k}\Omega$, whose closest standard resistor is 7.32 kΩ (1%).

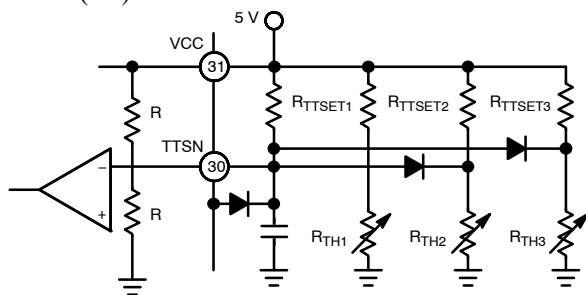

Figure 31. Multiple-Point Thermal Monitoring

The number of hot spots monitored is not limited. The alarm temperature of each hot spot can be set differently by playing different R_{TTSET1} , R_{TTSET2} , and R_{TTSETn} .

Tuning Procedure for ADP3207C

1. Build the circuit based on compensation values computed from Equations 1 to 41.
2. Hook-up the dc load to the circuit. Turn the circuit on and verify operation. Check for jitter at no load and full load.

DC Loadline Setting

3. Measure the output voltage at no load (V_{NL}). Verify that it is within tolerance.
4. Measure the output voltage at full load and at cold (V_{FLCOLD}). Let the board set for ~10 minutes at full load and measure the output (V_{FLHOT}). If there is a change of more than a few mV, then adjust R_{CS1} and R_{CS2} using Equations 42 and 43.

$$R_{CS2(NEW)} = R_{CS2(OLD)} \times \frac{V_{NL} - V_{FLCOLD}}{V_{NL} - V_{FLHOT}} \quad (\text{eq. 42})$$

5. Repeat Step 4 until cold and hot voltage measurements remain the same.
6. Measure output voltage from no load to full load using 5 A steps. Compute the load line slope for each change and then average it to get the overall load line slope (R_{OMEAS}).
7. If R_{OMEAS} is off from R_O by more than 0.05 mΩ, use the following to adjust the R_{PH} values:

$$R_{PH(NEW)} = R_{PH(OLD)} \times \frac{R_{OMEAS}}{R_O} \quad (\text{eq. 43})$$

8. Repeat Steps 6 and 7 to check load line and repeat adjustments if necessary.
9. Once completed with dc load line adjustment, do not change R_{PH} , R_{CS1} , R_{CS2} , or R_{TH} for the rest of procedure.
10. Measure output ripple at no load and full load with a scope to make sure it is within specification.

AC Loadline Setting

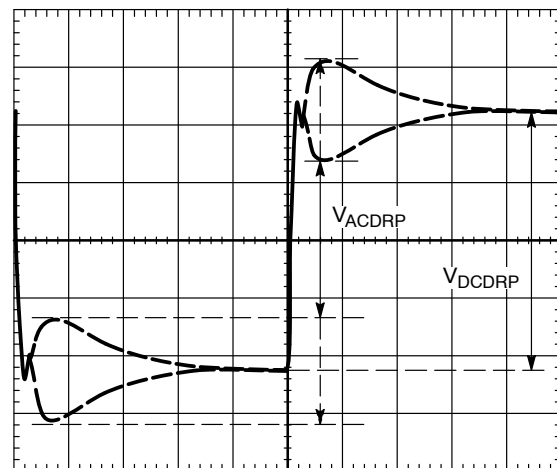

Figure 32. AC Loadline Waveform

11. Remove the dc load from the circuit and hook up the dynamic load.
12. Hook up the scope to the output voltage and set it to dc coupling with the time scale at 100 μs/div.
13. Set the dynamic load for a transient step of about 40 A at 1 kHz with a 50% duty cycle.
14. Measure the output waveform (using the dc offset on scope to see the waveform, if necessary). Try to use the vertical scale of 100 mV/div or finer.

15. Users should see a waveform that is similar to the one in Figure 33. Use the horizontal cursors to measure V_{ACDRP} and V_{DCDRP} as shown. Do not measure the undershoot or overshoot that occurs immediately after the step.
16. If the V_{ACDRP} and V_{DCDRP} are different by more than a couple of mV, use the following to adjust C_{CS} . (Note that users may need to parallel different values to get the right one due to the limited standard capacitor values available. It is also wise to have locations for two capacitors in the layout for this.)

$$C_{CS(NEW)} = C_{CS(OLD)} \times \frac{V_{ACDRP}}{V_{DCDRP}} \quad (\text{eq. 44})$$

17. Repeat Step 15 and Step 16. Repeat adjustments if necessary. Once completed, do not change C_{CS} for the rest of the procedure.
18. Set dynamic load step to maximum step size. Do not use a step size larger than needed. Verify that the output waveform is square, which means V_{ACDRP} and V_{DCDRP} are equal. Note: Make sure that the load step slew rate and turn-on are set for a slew rate of $\sim 150 \text{ A}/\mu\text{s}$ to $250 \text{ A}/\mu\text{s}$ (for example, a load step of 50 A should take 200 ns to 300 ns) with no overshoot. Some dynamic loads have an excessive turn-on overshoot if a minimum current is not set properly (this is an issue if using a V_{TT} tool).

Initial Transient Setting

19. With dynamic load still set at the maximum step size, expand the scope time scale to see $2 \mu\text{s}/\text{div}$ to $5 \mu\text{s}/\text{div}$. A waveform that has two overshoots and one minor undershoot can result (see Figure 33). Here, V_{DROOP} is the final desired value.

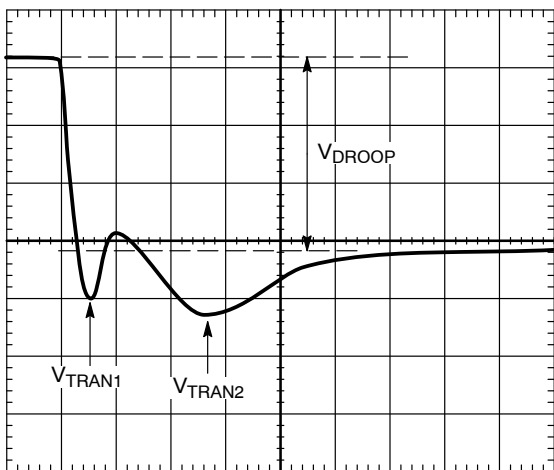

Figure 33. Transient Setting Waveform, Load Step

20. If both overshoots are larger than desired, make the following adjustments in the order they appear. Note that if these adjustments do not change the response, users are limited by the output decoupling. In addition, check the output response each time a change is made, as well as the switching nodes to make sure they are still stable.
- Make ramp resistor larger by 25% (R_{RAMP}).

b. For V_{TRAN1} , increase C_B or increase switching frequency.

c. For V_{TRAN2} , increase R_A and decrease C_A , both by 25%.

21. For load release (see Figure 34), if $V_{TRANREL}$ is larger than the IMVP-6 specification, there is not enough output capacitance. Either more capacitance is needed or the inductor values need to be smaller. If the inductors are changed, then start the design over using Equations 1 to 38 and this tuning guide.

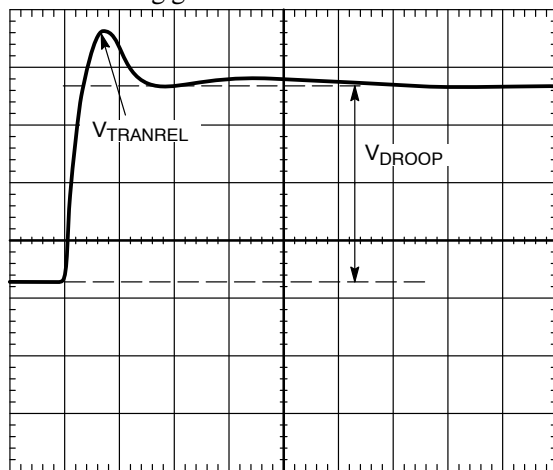

Figure 34. Transient Setting Waveform, Load Release

Layout and Component Placement

The following guidelines are recommended for optimal performance of a switching regulator in a PC system.

General Recommendations

For effective results, at least a 4-layer PCB is recommended. This allows the needed versatility for control circuitry interconnections with optimal placement, power planes for ground, input and output power, and wide interconnection traces in the rest of the power delivery current paths. Note that each square unit of 1 ounce copper trace has a resistance of $\sim 0.53 \text{ m}\Omega$ at room temperature.

When high currents need to be routed between PCB layers, vias should be used liberally to create several parallel current paths so that the resistance and inductance introduced by these current paths are minimized, and the via current rating is not exceeded.

If critical signal lines (including the output voltage sense lines of the ADP3207C) must cross through power circuitry, a signal ground plane should be interposed between those signal lines and the traces of the power circuitry. This serves as a shield to minimize noise injection into the signals at the expense of making signal ground a bit noisier.

An analog ground plane should be used around and under the ADP3207C for referencing the components associated with the controller. Tie this plane to the nearest output decoupling capacitor ground. It should not be tied to any other power circuitry to prevent power currents from flowing in it.

ADP3207C

The best location for the ADP3207C is close to the CPU corner where all the related signal pins are located: VID0 to VID6, \overline{PSI} , $V_{CCSENSE}$, and $V_{SSSENSE}$. The components around the ADP3207C should be located close to the controller with short traces. The most important traces to keep short and away from other traces are the FB and CSSUM pins (refer to Figure 28 for more details on layout for the CSSUM node.) The MLCC for the V_{CC} decoupling should be placed as close to the V_{CC} pin as possible. In addition, the noise filtering capacitor on the TTSENSE pin should also be as close to that pin as possible.

The output capacitors should be connected as closely as possible to the load (or connector) that receives the power (for example, a microprocessor core). If the load is distributed, then the capacitors should also be distributed, and generally in proportion to where the load tends to be more dynamic.

Power Circuitry

Avoid crossing any signal lines over the switching power path loop. This path should be routed on the PCB to encompass the shortest possible length to minimize radiated switching noise energy (that is, EMI) and conduction losses in the board. Failure to take proper precautions often results in EMI problems for the entire PC system as well as noise-related operational problems in the power converter control circuitry. The switching power path is the loop formed by the current path through the input capacitors and the power MOSFETs, including all interconnecting PCB traces and planes. The use of short and wide interconnection traces is especially critical in this path for two reasons: it minimizes the inductance in the switching loop, which can cause high energy ringing, and it accommodates the high current demand with minimal voltage loss.

Whenever a power-dissipating component (for example, a power MOSFET) is soldered to a PCB, the liberal use of vias, both directly on the mounting pad and immediately surrounding it, is recommended. Two important reasons for this are: improved current rating through the vias, and improved thermal performance from vias extended to the

opposite side of the PCB where a plane can more readily transfer the heat to the air. Make a mirror image of any pad being used to heat sink the MOSFETs on the opposite side of the PCB to achieve the best thermal dissipation to the air around the board. To further improve thermal performance, the largest possible pad area should be used.

The output power path should also be routed to encompass a short distance. The output power path is formed by the current path through the inductor, the output capacitors, and the load.

For best EMI containment, use a solid power ground plane as one of the inner layers extending fully under all the power components.

It is important for conversion efficiency that MOSFET drivers, such as ADP3611, are placed as close to the MOSFETs as possible. Thick and short traces are required between the driver and MOSFET gate, especially for the SR MOSFETs. Ground the MOSFET driver's GND pin through the closest vias.

Signal Circuitry

The output voltage is sensed and regulated between the FB pin and the FBRTN pin, which connects to the signal ground at the load. To avoid differential mode noise pickup in the sensed signal, the loop area should be small. Therefore, route the FB and FBRTN traces adjacent to each other atop the power ground plane back to the controller. To filter any noise from the FBRTN trace, using a 1000 pF MLCC is suggested. It should be placed between the FBRTN pin and local ground and as close to the FBRTN pin as possible.

Connect the feedback traces from the switch nodes as close as possible to the inductor. The CSREF signal should be Kelvin connected to the center point of the copper bar, which is the VCore common node for the inductors of all phases.

On the back side of the ADP3207C package, a metal pad can be used as the device heat sink. In addition, running vias under the ADP3207C is not recommended because the metal pad can cause shorting between vias.

ORDERING INFORMATION

Device	Temperature Range	Package	Shipping [†]
ADP3207CJCPZ-RL	0°C to 100°C	LFCSP40	2500 / Tape & Reel
ADP3207CFJCPZ-RL	0°C to 100°C	LFCSP40	2500 / Tape & Reel

[†]For information on tape and reel specifications, including part orientation and tape sizes, please refer to our Tape and Reel Packaging Specifications Brochure, BRD8011/D.

*The "Z" suffix indicates Pb-Free part.

MECHANICAL CASE OUTLINE

PACKAGE DIMENSIONS

ON Semiconductor®



LFCSP40 6x6, 0.5P
CASE 932AC-01
ISSUE A

DATE 23 JAN 2009

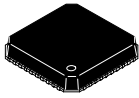

SCALE 2:1

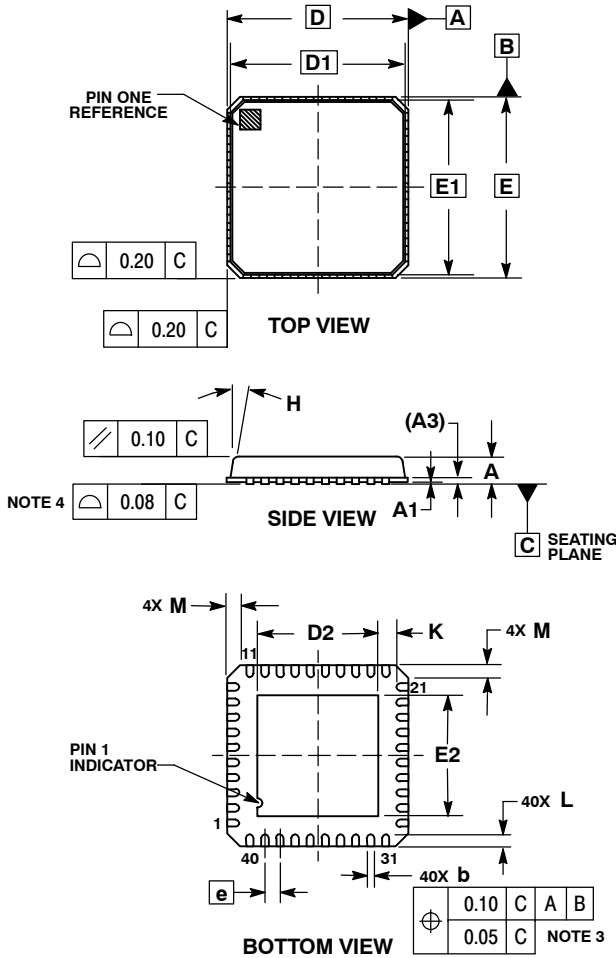

NOTES:

1. DIMENSIONING AND TOLERANCING PER ASME Y14.5M, 1994.
2. CONTROLLING DIMENSIONS: MILLIMETERS.
3. DIMENSION b APPLIES TO PLATED TERMINAL AND IS MEASURED BETWEEN 0.15 AND 0.30mm FROM THE TERMINAL TIP.
4. COPLANARITY APPLIES TO THE EXPOSED PAD AS WELL AS THE TERMINALS.

MILLIMETERS		
DIM	MIN	MAX
A	0.80	1.00
A1	0.00	0.05
A3	0.20	REF
b	0.18	0.30
D	6.00	BSC
D1	5.75	BSC
D2	3.95	4.25
E	6.00	BSC
E1	5.75	BSC
E2	3.95	4.25
e	0.50	BSC
H	---	12°
K	0.20	---
L	0.30	0.50
M	---	0.60

SOLDERING FOOTPRINT*

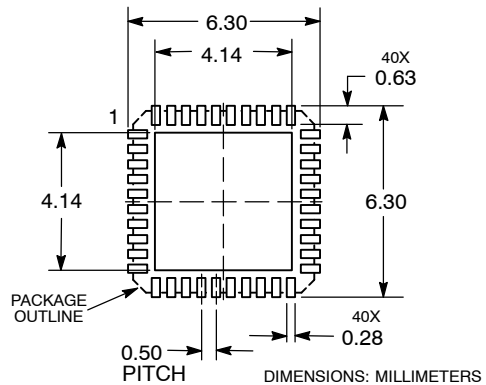

*For additional information on our Pb-Free strategy and soldering details, please download the ON Semiconductor Soldering and Mounting Techniques Reference Manual, SOLDERRM/D.

DOCUMENT NUMBER:	98AON26682D	Electronic versions are uncontrolled except when accessed directly from the Document Repository. Printed versions are uncontrolled except when stamped "CONTROLLED COPY" in red.
STATUS:	ON SEMICONDUCTOR STANDARD	
NEW STANDARD:		
DESCRIPTION:	LFCSP40, 6x6, 0.5P	PAGE 1 OF 2

onsemi, **Onsemi**, and other names, marks, and brands are registered and/or common law trademarks of Semiconductor Components Industries, LLC dba "**onsemi**" or its affiliates and/or subsidiaries in the United States and/or other countries. **onsemi** owns the rights to a number of patents, trademarks, copyrights, trade secrets, and other intellectual property. A listing of **onsemi**'s product/patent coverage may be accessed at www.onsemi.com/site/pdf/Patent-Marking.pdf. **onsemi** reserves the right to make changes at any time to any products or information herein, without notice. The information herein is provided "as-is" and **onsemi** makes no warranty, representation or guarantee regarding the accuracy of the information, product features, availability, functionality, or suitability of its products for any particular purpose, nor does **onsemi** assume any liability arising out of the application or use of any product or circuit, and specifically disclaims any and all liability, including without limitation special, consequential or incidental damages. Buyer is responsible for its products and applications using **onsemi** products, including compliance with all laws, regulations and safety requirements or standards, regardless of any support or applications information provided by **onsemi**. "Typical" parameters which may be provided in **onsemi** data sheets and/or specifications can and do vary in different applications and actual performance may vary over time. All operating parameters, including "Typicals" must be validated for each customer application by customer's technical experts. **onsemi** does not convey any license under any of its intellectual property rights nor the rights of others. **onsemi** products are not designed, intended, or authorized for use as a critical component in life support systems or any FDA Class 3 medical devices or medical devices with a same or similar classification in a foreign jurisdiction or any devices intended for implantation in the human body. Should Buyer purchase or use **onsemi** products for any such unintended or unauthorized application, Buyer shall indemnify and hold **onsemi** and its officers, employees, subsidiaries, affiliates, and distributors harmless against all claims, costs, damages, and expenses, and reasonable attorney fees arising out of, directly or indirectly, any claim of personal injury or death associated with such unintended or unauthorized use, even if such claim alleges that **onsemi** was negligent regarding the design or manufacture of the part. **onsemi** is an Equal Opportunity/Affirmative Action Employer. This literature is subject to all applicable copyright laws and is not for resale in any manner.

ADDITIONAL INFORMATION

TECHNICAL PUBLICATIONS:

Technical Library: www.onsemi.com/design/resources/technical-documentation
onsemi Website: www.onsemi.com

ONLINE SUPPORT: www.onsemi.com/support

For additional information, please contact your local Sales Representative at www.onsemi.com/support/sales