

MOSFET – N-Channel, POWERTRENCH®

60 V, 77 A, 4.1 mΩ

FDPF041N06BL1-F154

Description

This N-Channel MOSFET is produced using ON Semiconductor's advanced POWERTRENCH process that has been tailored to minimize the on-state resistance while maintaining superior switching performance.

Features

- $R_{DS(on)} = 3.5 \text{ m}\Omega$ (Typ.) @ $V_{GS} = 10 \text{ V}$, $I_D = 77 \text{ A}$
- Low FOM $R_{DS(on)} * Q_G$
- Low Reverse Recovery Charge, Q_{rr}
- Soft Reverse Recovery Body Diode
- Enables Highly Efficiency in Synchronous Rectification
- Fast Switching Speed
- 100% UIL Tested
- These Devices are Pb-Free and are RoHS Compliant

Applications

- Synchronous Rectification for ATX / Server / Telecom PSU
- Battery Protection Circuit
- Motor Drives and Uninterruptible Power Supplies
- Renewable System



ON Semiconductor®

www.onsemi.com

V_{DSS}	$R_{DS(on)} \text{ MAX}$	$I_D \text{ MAX}$
60 V	4.1 mΩ @ 10 V	77 A

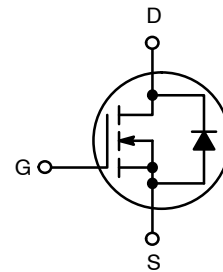

MOSFET

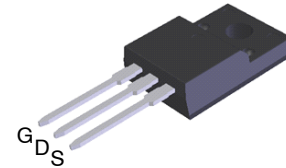

TO-220F Ultra Narrow Lead
CASE 221BN

MARKING DIAGRAM

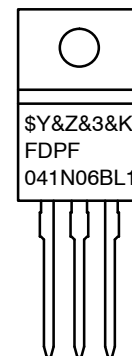

\$Y = ON Semiconductor Logo
&Z = Assembly Plant Code
&3 = Data Code (Year & Week)
&K = Lot
FDPF041N06BL1 = Specific Device Code

ORDERING INFORMATION

See detailed ordering and shipping information on page 2 of this data sheet.

FDPF041N06BL1-F154

ABSOLUTE MAXIMUM RATINGS (T_C = 25°C, Unless otherwise noted)

Symbol	Parameter	Value	Unit
V _{DSS}	Drain to Source Voltage	60	V
V _{GSS}	Gate to Source Voltage	±20	V
I _D	Drain Current	- Continuous (T _C = 25°C, Silicon Limited)	77
		- Continuous (T _C = 100°C, Silicon Limited)	55
I _{DM}	Drain Current	- Pulsed (Note 1)	308
E _{AS}	Single Pulsed Avalanche Energy (Note 2)	365	mJ
dv/dt	Peak Diode Recovery dv/dt (Note 3)	6.0	V/ns
P _D	Power Dissipation	(T _C = 25°C)	44.1
		- Derate Above 25°C	0.29
T _J , T _{STG}	Operating and Storage Temperature Range	-55 to +175	°C
T _L	Maximum Lead Temperature for Soldering Purpose, 1/8" from Case for 5 Seconds	300	°C

Stresses exceeding those listed in the Maximum Ratings table may damage the device. If any of these limits are exceeded, device functionality should not be assumed, damage may occur and reliability may be affected.

1. Repetitive rating: pulse-width limited by maximum junction temperature.
2. L = 3 mH, I_{AS} = 15,6 A, starting T_J = 25°C.
3. I_{SD} ≤ 100 A, di/dt ≤ 200 A/μs, V_{DD} ≤ BV_{DSS}, starting T_J = 25°C.

THERMAL CHARACTERISTICS

Symbol	Parameter	Value	Unit
R _{θJC}	Thermal Resistance, Junction to Case, Max.	3.4	°C/W
R _{θJA}	Thermal Resistance, Junction to Ambient, Max.	62.5	°C/W

PACKAGE MARKING AND ORDERING INFORMATION

Part Number	Top Marking	Package	Quantity
FDPF041N06BL1-F154	FDPF041N06BL1	TO-220F (Pb-Free)	50 Units / Tube

FDPF041N06BL1-F154

ELECTRICAL CHARACTERISTICS (T_C = 25°C unless otherwise noted)

Symbol	Parameter	Test Conditions	Min.	Typ.	Max.	Unit
--------	-----------	-----------------	------	------	------	------

OFF CHARACTERISTICS

BV _{DSS}	Drain to Source Breakdown Voltage	I _D = 250 μA, V _{GS} = 0 V	60	-	-	V
ΔBV _{DSS} / ΔT _J	Breakdown Voltage Temperature Coefficient	I _D = 250 μA, Referenced to 25°C	-	0.03	-	V/°C
I _{DSS}	Zero Gate Voltage Drain Current	V _{DS} = 48 V, V _{GS} = 0 V	-	-	1	μA
I _{GSS}	Gate to Body Leakage Current	V _{GS} = ±20 V, V _{DS} = 0 V	-	-	±100	nA

ON CHARACTERISTICS

V _{GS(th)}	Gate Threshold Voltage	V _{GS} = V _{DS} , I _D = 250 μA	2	-	4	V
R _{DS(on)}	Static Drain to Source On Resistance	V _{GS} = 10 V, I _D = 77 A	-	3.5	4.1	mΩ
g _{FS}	Forward Transconductance	V _{DS} = 10 V, I _D = 77 A	-	125	-	S

DYNAMIC CHARACTERISTICS

C _{iss}	Input Capacitance	V _{DS} = 30 V, V _{GS} = 0 V, f = 1 MHz	-	4280	5690	pF
C _{oss}	Output Capacitance		-	1050	1400	pF
C _{rss}	Reverse Transfer Capacitance		-	23	-	pF
C _{oss(er)}	Energy Related Output Capacitance	V _{DS} = 30 V, V _{GS} = 0 V	-	1787	-	pF
Q _{g(tot)}	Total Gate Charge at 10 V	V _{DS} = 30 V, I _D = 100 A, V _{GS} = 10 V (Note 4)	-	53	69	nC
Q _{gs}	Gate to Source Gate Charge		-	23	-	nC
Q _{gd}	Gate to Drain "Miller" Charge		-	8	-	nC
V _{plateau}	Gate Plateau Voltage		-	5.7	-	V
Q _{sync}	Total Gate Charge Sync.	V _{DS} = 0 V, I _D = 50 A	-	48.6	-	nC
Q _{oss}	Output Charge	V _{DS} = 30 V, V _{GS} = 0 V	-	63.8	-	nC

SWITCHING CHARACTERISTICS

t _{d(on)}	Turn-On Delay Time	V _{DD} = 30 V, I _D = 100 A, V _{GS} = 10 V, R _{GEN} = 4.7 Ω (Note 4)	-	29	68	ns
t _r	Turn-On Rise Time		-	22	54	ns
t _{d(off)}	Turn-Off Delay Time		-	38	86	ns
t _f	Turn-Off Fall Time		-	11	32	ns
ESR	Equivalent Series Resistance (G-S)	f = 1 MHz	-	0,8	-	Ω

DRAIN-SOURCE DIODE CHARACTERISTICS

I _S	Maximum Continuous Source to Drain Diode Forward Current	-	-	77	A	
I _{SM}	Maximum Pulsed Source to Drain Diode Forward Current	-	-	308	A	
V _{SD}	Source to Drain Diode Forward Voltage	V _{GS} = 0 V, I _{SD} = 77 A	-	-	1.25	V
t _{rr}	Reverse Recovery Time	V _{GS} = 0 V, I _{SD} = 100 A, dI _F /dt = 100 A/μs	-	65	-	ns
Q _{rr}	Reverse Recovery Charge		-	63	-	nC

Product parametric performance is indicated in the Electrical Characteristics for the listed test conditions, unless otherwise noted. Product performance may not be indicated by the Electrical Characteristics if operated under different conditions.

4. Essentially independent of operating temperature typical characteristics.

TYPICAL PERFORMANCE CHARACTERISTICS

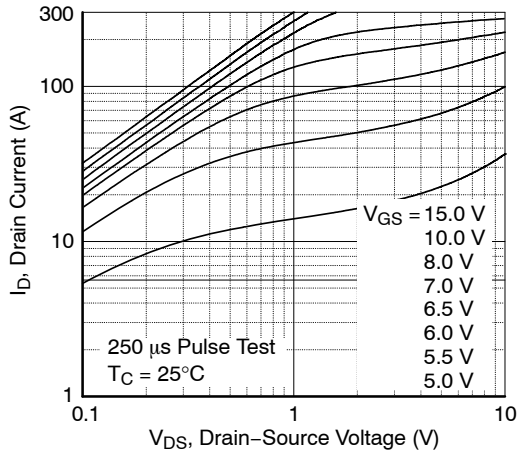

Figure 1. On-Region Characteristics

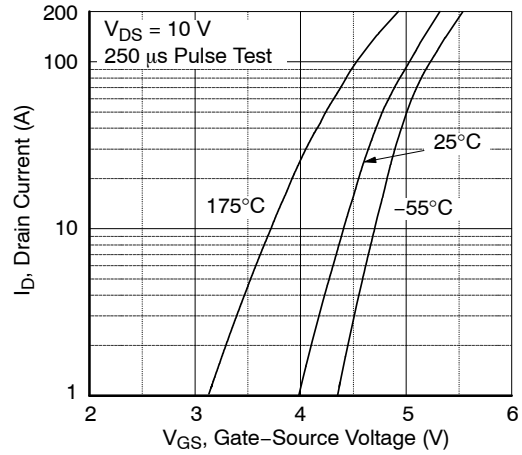

Figure 2. Transfer Characteristics

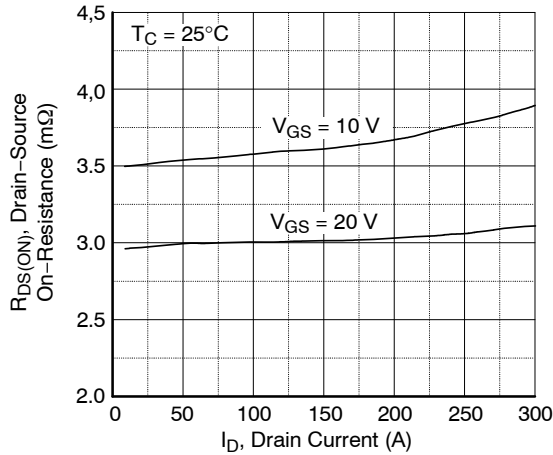

Figure 3. On-Resistance Variation vs. Drain Current and Gate Voltage

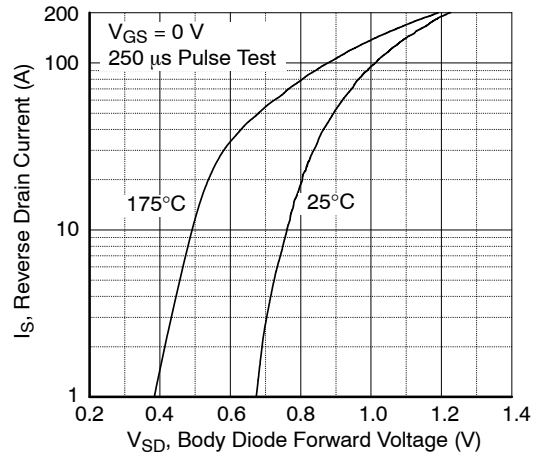

Figure 4. Body Diode Forward Voltage Variation vs. Source Current and Temperature

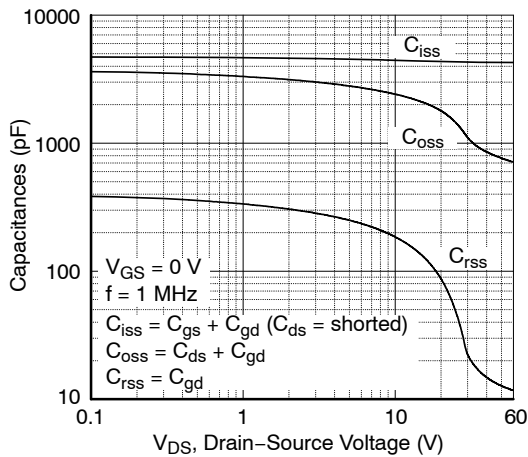

Figure 5. Capacitance Characteristics

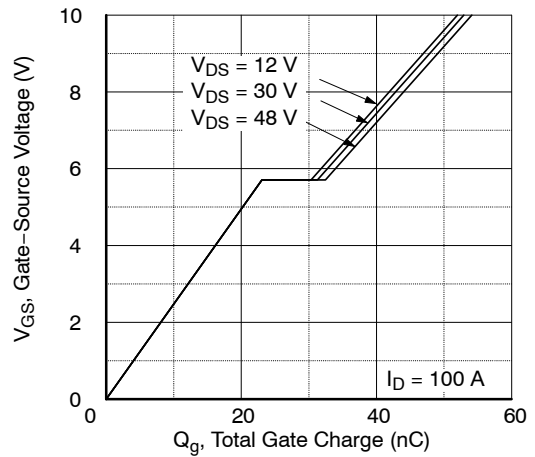

Figure 6. Gate Charge Characteristics

TYPICAL PERFORMANCE CHARACTERISTICS (continued)

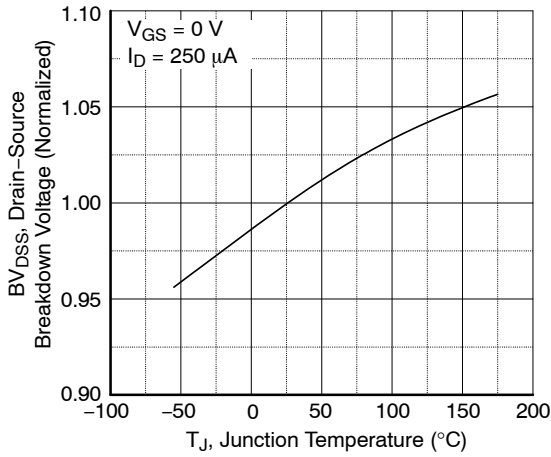

Figure 7. Breakdown Voltage Variation vs. Temperature

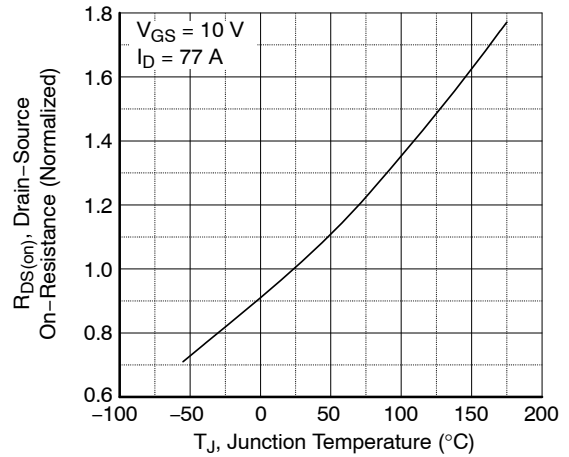

Figure 8. On-Resistance Variation vs. Temperature

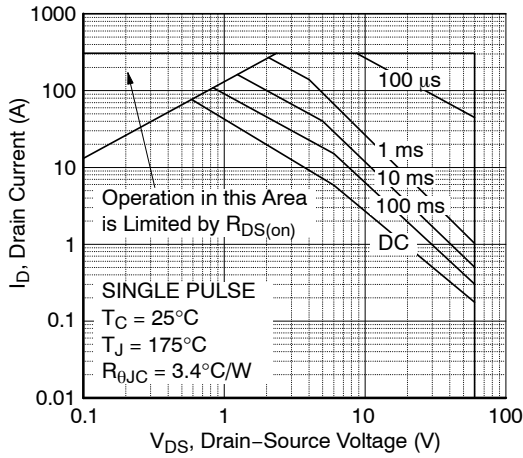

Figure 9. Maximum Safe Operating Area vs. Case Temperature

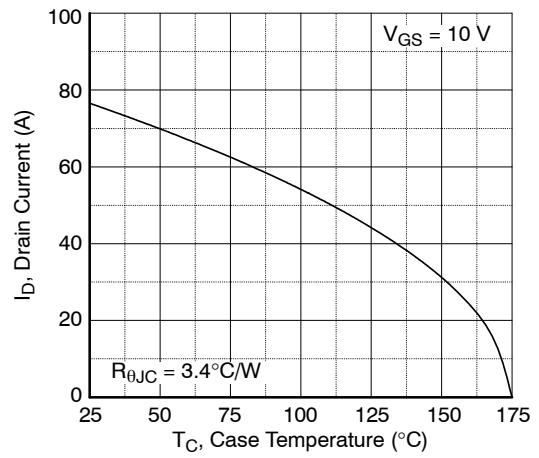

Figure 10. Maximum Drain Current vs. Case Temperature

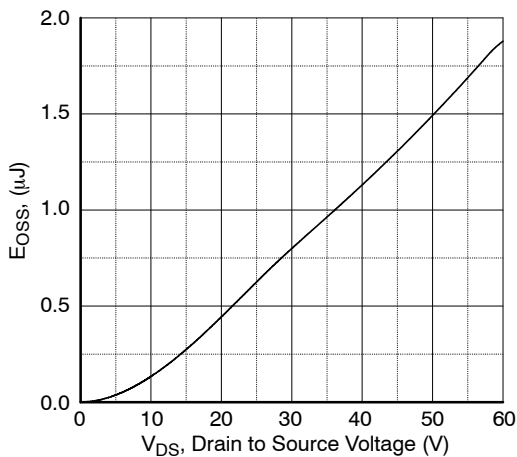

Figure 11. E_{OSS} vs. Drain to Source Voltage

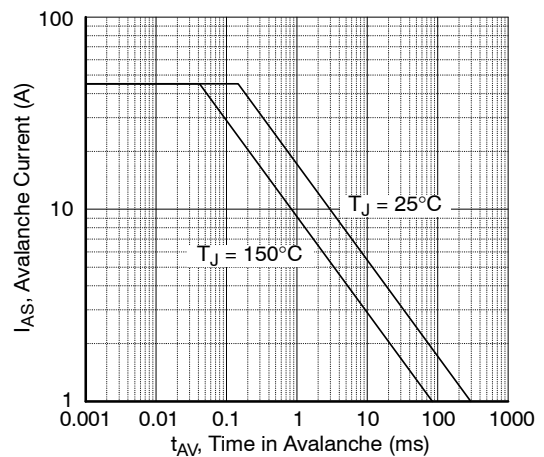

Figure 12. Unclamped Inductive Switching Capability

TYPICAL PERFORMANCE CHARACTERISTICS (continued)

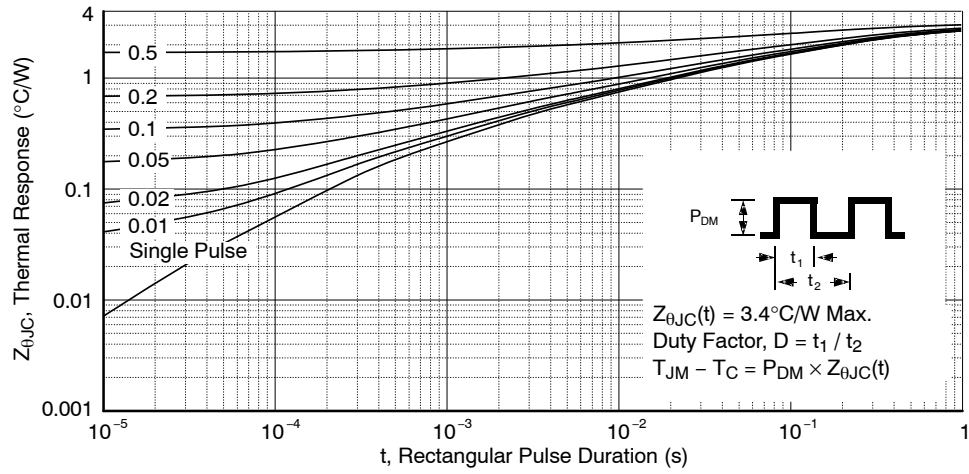

Figure 13. Transient Thermal Response Curve

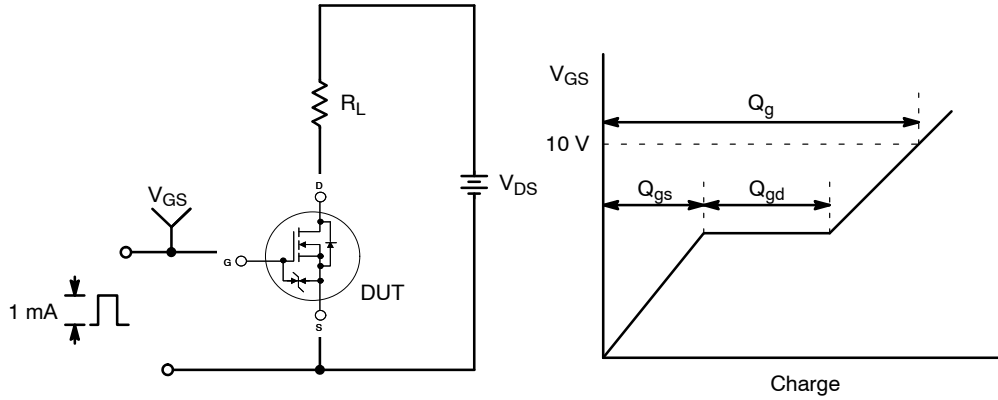

Figure 14. Gate Charge Test Circuit & Waveform

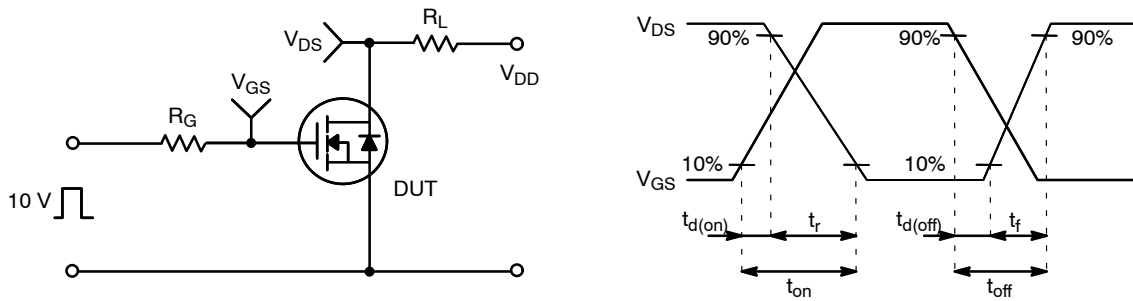

Figure 15. Resistive Switching Test Circuit & Waveforms

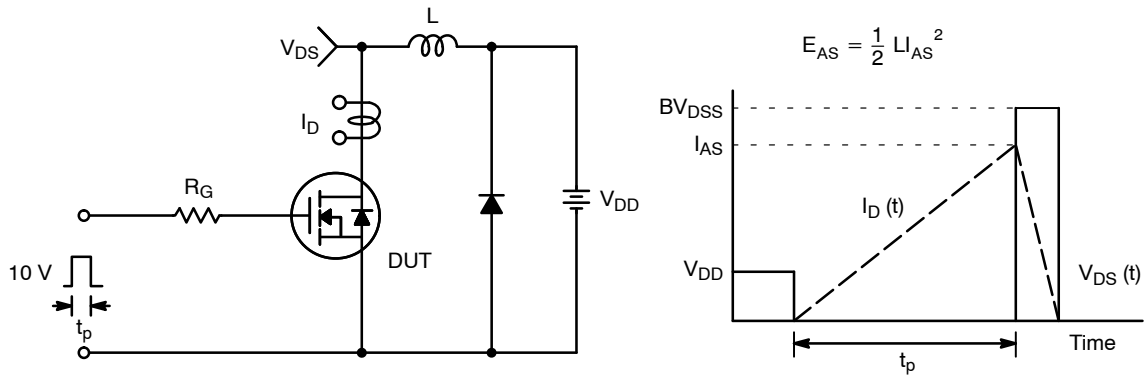

Figure 16. Unclamped Inductive Switching Test Circuit & Waveforms

FDPF041N06BL1-F154

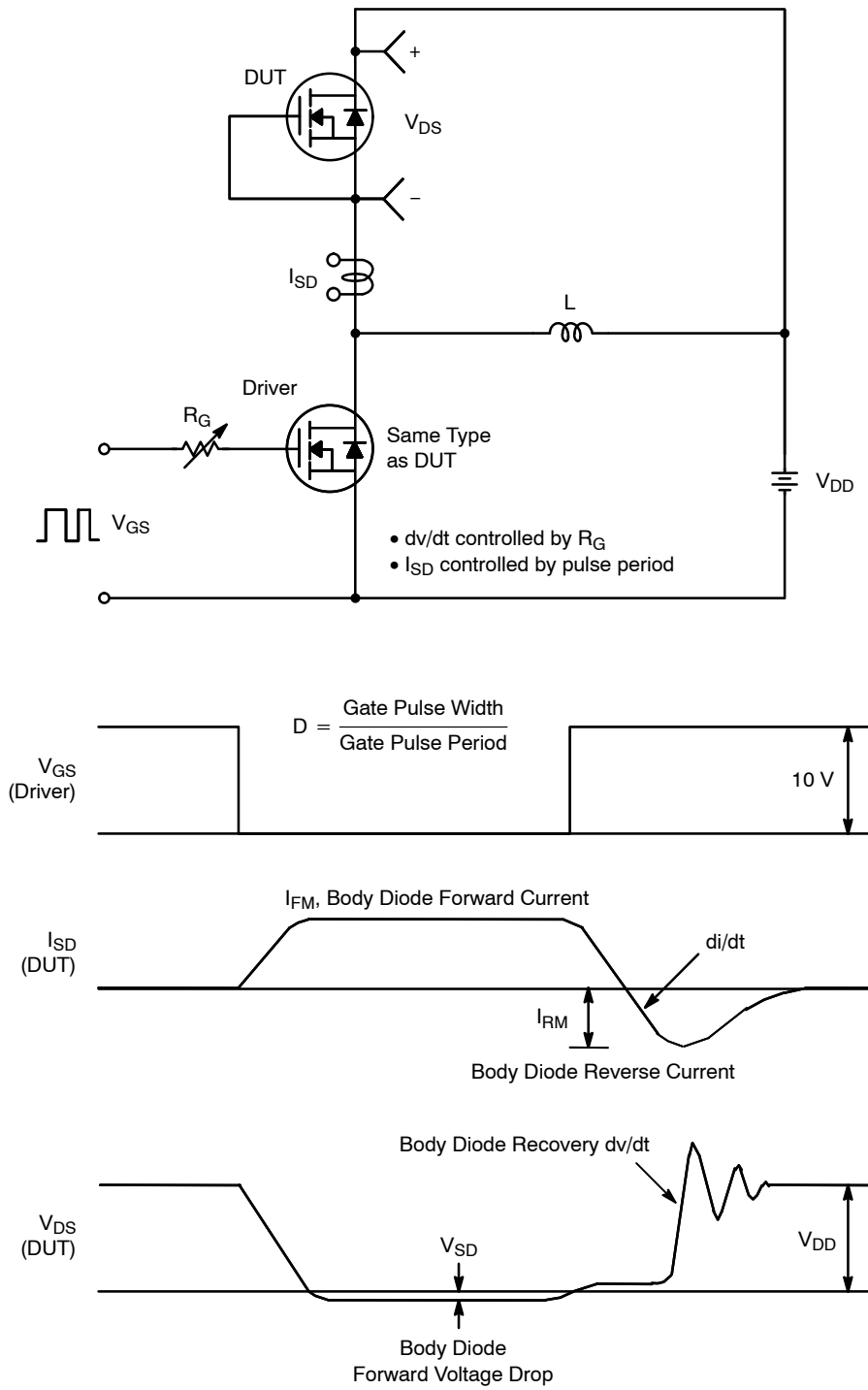

Figure 17. Peak Diode Recovery dv/dt Test Circuit & Waveforms

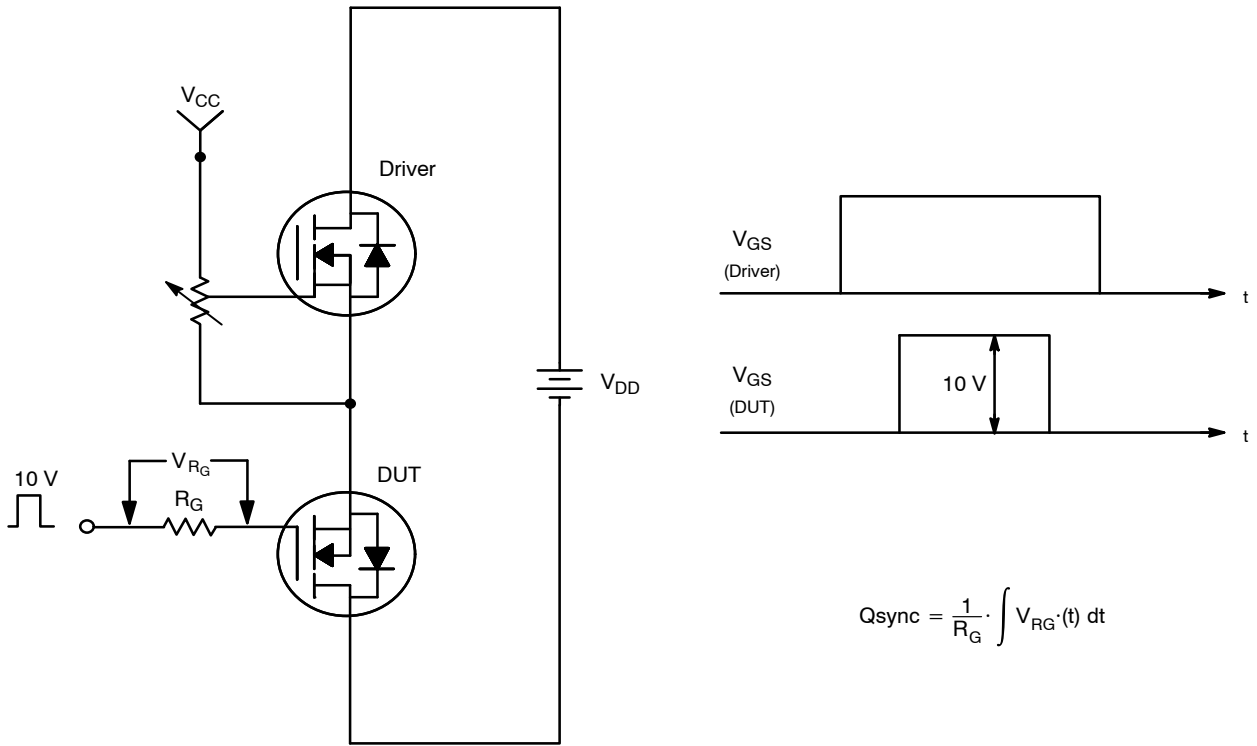
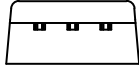

Figure 18. Total Gate Charge Q_{sync} . Test Circuit & Waveforms



TO-220 FULLPACK, 3-LEAD (ULTRA NARROW LEAD)
CASE 221BN
ISSUE A

DATE 07 MAY 2021



NOTES:

1. DIMENSIONING AND TOLERANCING PER ASME Y14.5M, 1994.
2. CONTROLLING DIMENSION: MILLIMETERS
3. CONTOUR UNCONTROLLED IN THIS AREA.
4. DIMENSIONS EXCLUDE BURRS, MOLD FLASH, AND TIE BAR PROTRUSIONS.

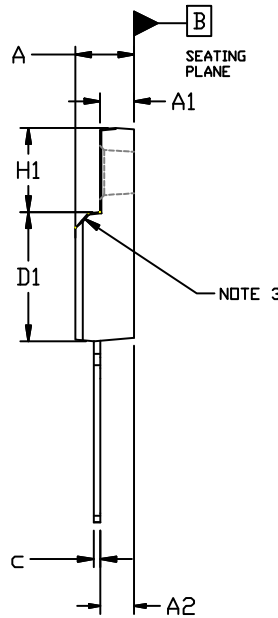
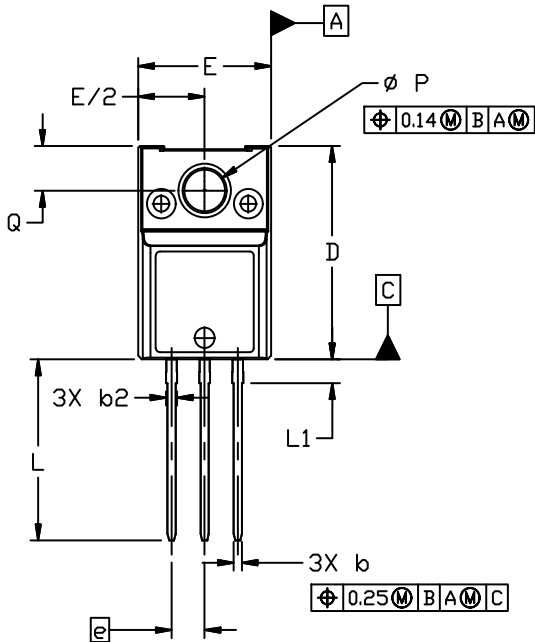

DIM	MILLIMETERS		
	MIN.	NOM.	MAX.
A	4.60	4.70	4.80
A1	2.50	2.60	2.70
A2	2.47	2.57	2.67
b	0.56	0.63	0.69
b2	---	---	0.90
c	0.46	0.53	0.59
D	15.80	16.00	16.20
D1	9.58	9.68	9.78
E	10.00	10.20	10.40
e	2.54 BSC		
H1	6.32 REF		
L	13.45	13.60	13.75
L1	1.70	1.80	1.90
P	3.00	3.10	3.20
Q	3.25	3.35	3.45

GENERIC MARKING DIAGRAM*

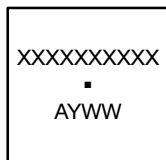

- XXXX = Specific Device Code
- A = Assembly Location
- Y = Year
- WW = Work Week
- = Pb-Free Package

*This information is generic. Please refer to device data sheet for actual part marking. Pb-Free indicator, "G" or microdot "▪", may or may not be present. Some products may not follow the Generic Marking.

DOCUMENT NUMBER:	98AON01135H	Electronic versions are uncontrolled except when accessed directly from the Document Repository. Printed versions are uncontrolled except when stamped "CONTROLLED COPY" in red.
DESCRIPTION:	TO-220 FULLPACK, 3-LEAD (ULTRA NARROW LEAD)	PAGE 1 OF 1

ON Semiconductor and ON are trademarks of Semiconductor Components Industries, LLC dba ON Semiconductor or its subsidiaries in the United States and/or other countries. ON Semiconductor reserves the right to make changes without further notice to any products herein. ON Semiconductor makes no warranty, representation or guarantee regarding the suitability of its products for any particular purpose, nor does ON Semiconductor assume any liability arising out of the application or use of any product or circuit, and specifically disclaims any and all liability, including without limitation special, consequential or incidental damages. ON Semiconductor does not convey any license under its patent rights nor the rights of others.

onsemi, **Onsemi**, and other names, marks, and brands are registered and/or common law trademarks of Semiconductor Components Industries, LLC dba "**onsemi**" or its affiliates and/or subsidiaries in the United States and/or other countries. **onsemi** owns the rights to a number of patents, trademarks, copyrights, trade secrets, and other intellectual property. A listing of **onsemi**'s product/patent coverage may be accessed at www.onsemi.com/site/pdf/Patent-Marking.pdf. **onsemi** reserves the right to make changes at any time to any products or information herein, without notice. The information herein is provided "as-is" and **onsemi** makes no warranty, representation or guarantee regarding the accuracy of the information, product features, availability, functionality, or suitability of its products for any particular purpose, nor does **onsemi** assume any liability arising out of the application or use of any product or circuit, and specifically disclaims any and all liability, including without limitation special, consequential or incidental damages. Buyer is responsible for its products and applications using **onsemi** products, including compliance with all laws, regulations and safety requirements or standards, regardless of any support or applications information provided by **onsemi**. "Typical" parameters which may be provided in **onsemi** data sheets and/or specifications can and do vary in different applications and actual performance may vary over time. All operating parameters, including "Typicals" must be validated for each customer application by customer's technical experts. **onsemi** does not convey any license under any of its intellectual property rights nor the rights of others. **onsemi** products are not designed, intended, or authorized for use as a critical component in life support systems or any FDA Class 3 medical devices or medical devices with a same or similar classification in a foreign jurisdiction or any devices intended for implantation in the human body. Should Buyer purchase or use **onsemi** products for any such unintended or unauthorized application, Buyer shall indemnify and hold **onsemi** and its officers, employees, subsidiaries, affiliates, and distributors harmless against all claims, costs, damages, and expenses, and reasonable attorney fees arising out of, directly or indirectly, any claim of personal injury or death associated with such unintended or unauthorized use, even if such claim alleges that **onsemi** was negligent regarding the design or manufacture of the part. **onsemi** is an Equal Opportunity/Affirmative Action Employer. This literature is subject to all applicable copyright laws and is not for resale in any manner.

ADDITIONAL INFORMATION

TECHNICAL PUBLICATIONS:

Technical Library: www.onsemi.com/design/resources/technical-documentation
onsemi Website: www.onsemi.com

ONLINE SUPPORT: www.onsemi.com/support

For additional information, please contact your local Sales Representative at www.onsemi.com/support/sales