

FSA646A

2:1 MIPI D-PHY (4.5 Gbps) 4-Data-Lane & C-PHY (3.5 Gbps) 3-Data-Lane Switch

Description

The FSA646A can be configured as a four-data-lane MIPI, D-PHY switch or a three-data-lane MIPI, C-PHY switch. This single-pole, double-throw (SPDT) switch is optimized for switching between two high-speed or low-power MIPI sources. The FSA646A is designed for the MIPI specification and allows connection to a CSI or DSI module.

Features

- Switch Type: SPDT (10x)
- Signal Types:
 - ◆ MIPI, D-PHY V2.1 & C-PHY V1.2
- V_{CC} : 1.5 to 5.0 V
- Input Signals: 0 to 1.3 V
- R_{ON} :
 - ◆ 6 Ω Typical HS MIPI
 - ◆ 6 Ω Typical LP MIPI
- ΔR_{ON} : 0.1 Ω Typical LP & HS MIPI
- ΔR_{ON_FLAT} : 0.9 Ω Typical LP & HS MIPI
- I_{CCZ} : 1 μ A Maximum
- I_{CC} : 30 μ A Maximum
- O_{IRR} : -24 dB Typical
- Bandwidth: 4.7 GHz Typical
- Xtalk: -30 dB Typical
- C_{ON} : 1.4 pF Typical
- Skew (P), Skew (O): 6 ps Typical

Applications

- Cellular Phones, Smart Phones
- Tablets
- Laptops
- Displays



ON Semiconductor®

www.onsemi.com

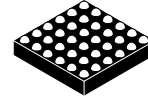

(Bottom View)

WLCSP36,
2.43x2.43x0.599
CASE 567XH

MARKING DIAGRAM



GQ = Specific Device Code
KK = Assembly Lot
X = Year
Y = Work Week
Z = Assembly Location

ORDERING INFORMATION

See detailed ordering and shipping information on page 7 of this data sheet.

FSA646A

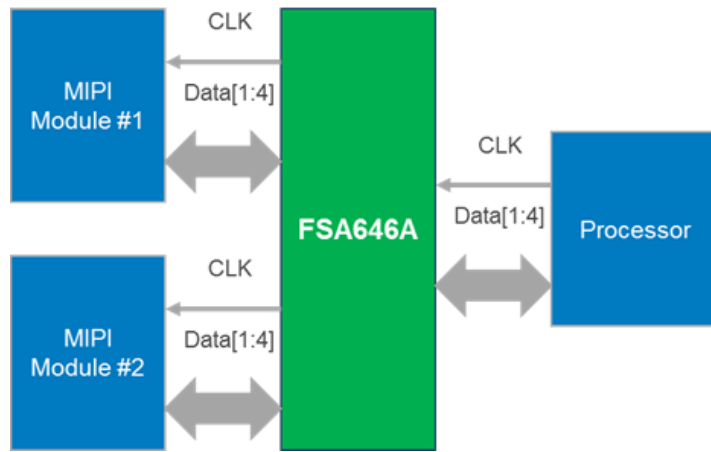
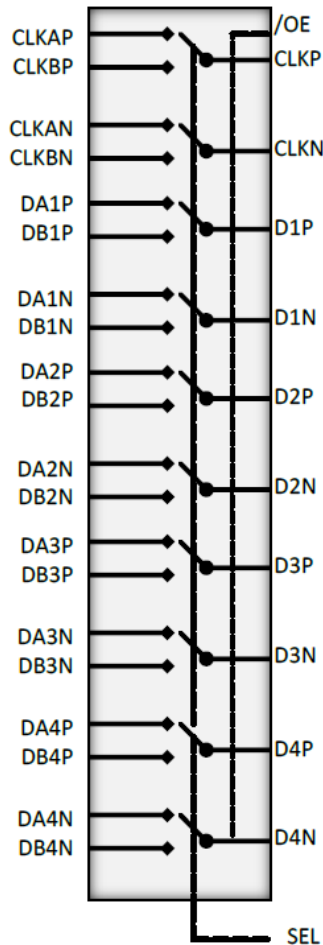

Figure 1. Typical D-PHY Application

PIN DESCRIPTIONS



Pin Name	Description		
CLKBP/N	B Side Clock Path		
DB1P/N	B Side Data Path 1		
DB2P/N	B Side Data Path 2		
DB3P/N	B Side Data Path 3		
DB4P/N	B Side Data Path 4		
CLKAP/N	A Side Clock Path		
DA1P/N	A Side Data Path 1		
DA2P/N	A Side Data Path 2		
DA3P/N	A Side Data Path 3		
DA4P/N	A Side Data Path 4		
CLKP/N	Common Clock Path		
D1P/N	Common Data Path 1		
D2P/N	Common Data Path 2		
D3P/N	Common Data Path 3		
D4P/N	Common Data Path 4		
/OE	Output Enable		
SEL	Control Pin	SEL=0	CLKP/N=CLKAP/N, DnP/N=DA nP/N
		SEL=1	CLKP/N=CLKBP/N, DnP/N=DB nP/N
VCC	Power		
GND	Ground		
NC	No Connect		

Figure 2. Analog Symbol

FSA646A

PIN DEFINITIONS

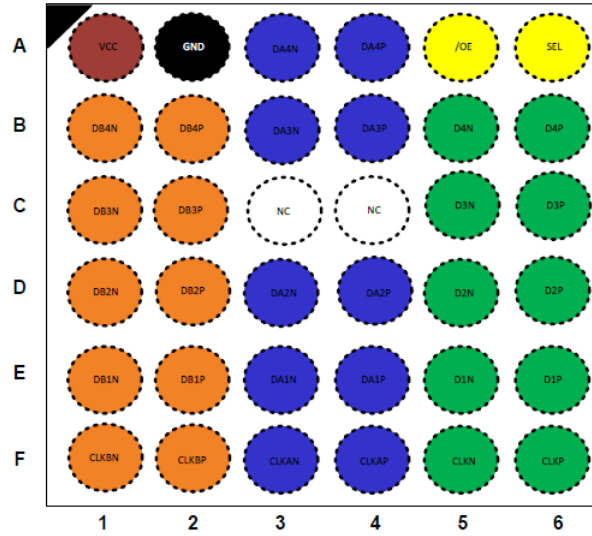

Figure 3. Top Through View

Table 1. BALL-TO-PIN MAPPINGS

Ball	Pin Name	Ball	Pin Name	Ball	Pin Name
A1	V _{CC}	C1	DB3N	E1	DB1N
A2	GND	C2	DB3P	E2	DB1P
A3	DA4N	C3	NC	E3	DA1N
A4	DA4P	C4	NC	E4	DA1P
A5	/OE	C5	D3N	E5	D1N
A6	SEL	C6	D3P	E6	D1P
B1	DB4N	D1	DB2N	F1	CLKBN
B2	DB4P	D2	DB2P	F2	CLKBP
B3	DA3N	D3	DA2N	F3	CLKAN
B4	DA3P	D4	DA2P	F4	CLKAP
B5	D4N	D5	D2N	F5	CLKN
B6	D4P	D6	D2P	F6	CLKP

FSA646A

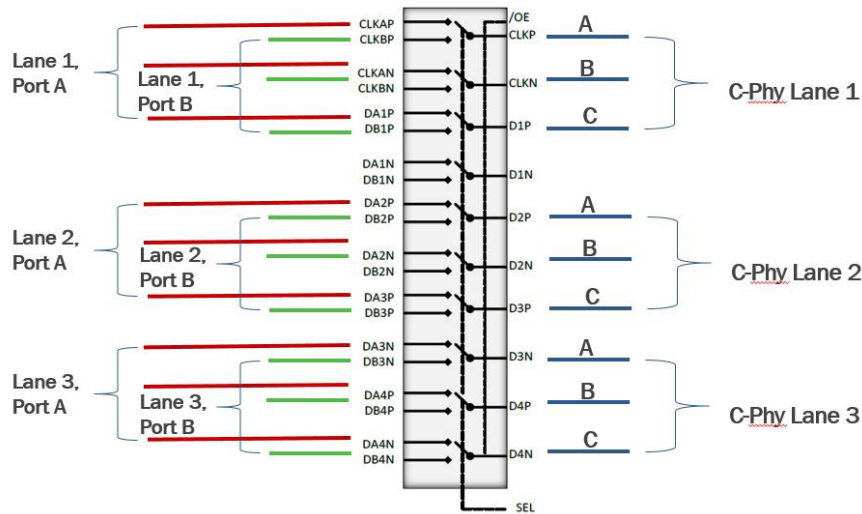

Figure 4. Recommended Configuration for C-PHY

TRUTH TABLE

SEL	/OE	Function
LOW	LOW	$CLK_P = CLKA_P, CLK_N = CLKA_N, Dn(P/N) = DAN(P/N)$
HIGH	LOW	$CLK_P = CLKB_P, CLK_N = CLKB_N, Dn(P/N) = DBn(P/N)$
X	HIGH	Clock and Data Ports High Impedance

ABSOLUTE MAXIMUM RATINGS

Symbol	Parameter		Min.	Max.	Unit
V_{CC}	Supply Voltage		-0.5	6.0	V
V_{CNTRL}	DC Input Voltage (/OE, SEL) (Note 1)		-0.5	V_{CC}	V
V_{SW}	DC Switch I/O Voltage (Note 1,2)		-0.3	2.1	V
I_{IK}	DC Input Diode Current		-50		mA
I_{OUT}	DC Output Current			25	mA
T_{STG}	Storage Temperature		-65	+150	°C
ESD	Human Body Model, JEDEC: JESD22-A114	All Pins	2.0		kV
	Charged Device Model, JEDEC: JESD22-C101		0.5		

Stresses exceeding those listed in the Maximum Ratings table may damage the device. If any of these limits are exceeded, device functionality should not be assumed, damage may occur and reliability may be affected.

1. The input and output negative ratings may be exceeded if the input and output diode current ratings are observed.
2. V_{SW} refers to analog data switch paths.

FSA646A

RECOMMENDED OPERATING CONDITIONS

Symbol	Parameter	Min.	Max.	Unit	
V _{CC}	Supply Voltage	1.5	5.0	V	
V _{CNTRL}	Control Input Voltage (SEL, /OE) (Note 3)	0	V _{CC}	V	
V _{SW}	Switch I/O Voltage (CLKn, Dn, CLKAn, CLKBn, Dan, DBn)	HS Mode	0	0.425	V
		LP Mode	-0.05	1.3	V
T _A	Operating Temperature	-40	+85	°C	

Functional operation above the stresses listed in the Recommended Operating Ranges is not implied. Extended exposure to stresses beyond the Recommended Operating Ranges limits may affect device reliability.

3. The control inputs must be held HIGH or LOW; they must not float.

DC AND TRANSIENT CHARACTERISTICS (T_A = 25°C unless otherwise specified)

Symbol	Parameter	Conditions	V _{CC} (V)	T _A = -40 to +85°C			Unit
				Min.	Typ.	Max.	
V _{IK}	Clamp Diode Voltage (/OE, SEL)	I _{IN} = -18 mA	1.5	-1.2		-0.6	V
V _{IH}	Input Voltage High	SEL, /OE	1.5 to 5	1.3			V
V _{IL}	Input Voltage Low	SEL, /OE	1.5 to 5			0.5	V
I _{IN}	Control Input Leakage (/OE, SEL)	V _{CNTRL} = 0 to V _{CC}	5	-0.5		0.5	μA
I _{NO(OFF)} I _{NC(OFF)}	Off Leakage Current of Port CLKAn, Dan, CLKBn and DBn	V _{SW} = 0.0 ≤ DATA ≤ 1.3 V	5	-0.5		0.5	μA
I _{A(ON)}	ON Leakage Current of Common Ports (CLKn, Dn)	V _{SW} = 0.0 ≤ DATA ≤ 1.3 V	5	-0.5		0.5	μA
I _{OFF}	Power-Off Leakage Current (All I/O Ports)	V _{SW} = 0.0 or 1.3 V	0	-0.5		0.5	μA
I _{OZ}	Off-State Leakage	V _{SW} = 0.0 ≤ DATA ≤ 1.3 V /OE = High	5	-0.5		0.5	μA
R _{ON_MIPI_HS}	Switch On Resistance for HS MIPI Applications (Note 4)	I _{ON} = -8 mA, /OE = 0 V, SEL = V _{CC} or 0 V, CLKA, CLKB, DB _N or DA _N = 0.2 V	1.5		6		Ω
			2.5				
			3.3				
			5				
R _{ON_MIPI_LP}	Switch On Resistance for LP MIPI Applications (Note 4)	I _{ON} = -8 mA, /OE = 0 V, SEL = V _{CC} or 0 V, CLKA, CLKB, DB _N or DA _N = 1.2 V	1.5		6		Ω
			2.5				
			3.3				
			5				
ΔR _{ON_MIPI_HS}	On Resistance Matching Between HS MIPI Channels (Note 4)	I _{ON} = -8 mA, /OE = 0 V, SEL = V _{CC} or 0 V, CLKA, CLKB, DB _N or DA _N = 0.2 V	1.5		0.1		Ω
			2.5				
			3.3				
			5				
ΔR _{ON_MIPI_LP}	On Resistance Matching Between LP MIPI Channels (Note 4)	I _{ON} = -8 mA, /OE = 0 V, SEL = V _{CC} or 0 V, CLKA, CLKB, DB _N or DA _N = 1.2 V	1.5		0.1		Ω
			2.5				
			3.3				
			5				

FSA646A

DC AND TRANSIENT CHARACTERISTICS ($T_A = 25^\circ\text{C}$ unless otherwise specified) (continued)

Symbol	Parameter	Conditions	V_{CC} (V)	$T_A = -40$ to $+85^\circ\text{C}$			Unit
				Min.	Typ.	Max.	
R _{ON_FLAT_MIPI_HS}	On Resistance Flatness for HS MIPI Signals (Note 4)	$I_{ON} = -8$ mA, /OE = 0 V, SEL = V_{CC} or 0 V, CLKA, CLKB, DB _N or DA _N = 0 to 0.3 V	1.5		0.9		Ω
			2.5				
			3.3				
			5				
R _{ON_FLAT_MIPI_LP}	On Resistance Flatness for LP MIPI Signals (Note 4)	$I_{ON} = -8$ mA, /OE = 0 V, SEL = V_{CC} or 0 V, CLKA, CLKB, DB _N or DA _N = 0 to 1.3 V	1.5		0.9		Ω
			2.5				
			3.3				
			5				
I _{CC}	Quiescent Supply Current (Includes Charge Pump)	$V_{SEL} = 0$ or V_{CC} , $I_{OUT} = 0$, /OE = 0 V	5			30	μA
I _{CCZ}	Quiescent Supply Current (High Impedance)	$V_{SEL} = 0$ or V_{CC} , $I_{OUT} = 0$, /OE = 0 V	5			1	μA
I _{CCT}	Increase in I _{CC} Current Per Control Voltage and V_{CC}	$V_{SEL} = 0$ or V_{CC} , /OE = 1.5 V	5		1		μA

4. Measured by the voltage drop at the indicated current through the switch.

AC ELECTRICAL CHARACTERISTICS ($V_{CC} = 3.3$ V and $T_A = 25^\circ\text{C}$ unless otherwise specified)

Symbol	Parameter	Conditions	V_{CC} (V)	$T_A = -40$ to $+85^\circ\text{C}$			Unit
				Min.	Typ.	Max.	
t _{INIT}	Initialization Time V_{CC} to Output (Note 5)	$R_L = 50$ Ω , $C_L = 0$ pF, $V_{SW} = 0.6$ V	1.5 to 5		60		μs
t _{EN}	Enable Time /OE to Output	$R_L = 50$ Ω , $C_L = 0$ pF, $V_{SW} = 0.6$ V	1.5 to 5		60	150	μs
t _{DIS}	Disable Time /OE to Output	$R_L = 50$ Ω , $C_L = 0$ pF, $V_{SW} = 0.6$ V	1.5 to 5		35	250	ns
t _{ON}	Turn-On Time SEL to Output	$R_L = 50$ Ω , $C_L = 0$ pF, $V_{SW} = 0.6$ V	1.5 to 5		350	1100	ns
t _{OFF}	Turn-Off Time SEL to Output	$R_L = 50$ Ω , $C_L = 0$ pF, $V_{SW} = 0.6$ V	1.5 to 5		125	800	ns
t _{BBM}	Break-Before-Make Time	$R_L = 50$ Ω , $C_L = 0$ pF, $V_{SW} = 0.6$ V	1.5 to 5	50		450	ns
t _{PD}	Propagation Delay (Note 5)	$C_L = 0$ pF, $R_L = 50$ Ω	1.5 to 5	30	67	100	ps
O _{IRR}	Off Isolation for MIPI (Note 5)	$R_L = 50$ Ω , $f = 2250$ MHz, /OE = HIGH, $V_{SW} = 0.2$ V _{PP}	1.5 to 5		-24		dB
X _{TALK}	Crosstalk for MIPI (Note 5)	$R_L = 50$ Ω , $f = 2250$ MHz, SEL = High, $V_{SW} = 0.2$ V _{PP}	1.5 to 5		-30	-25	dB
		$R_L = 50$ Ω , $f = 2250$ MHz, SEL = Low, $V_{SW} = 0.2$ V _{PP}			-30	-25	
BW	-3 db Bandwidth (Note 5)	$R_L = 50$ Ω , $C_L = 0$ pF, $V_{SW} = 0.2$ V _{PP}	1.5 to 5		4.7		GHz
IL	Insertion Loss at 750 MHz (Note 5)	$R_L = 50$ Ω , $C_L = 0$ pF, $V_{SW} = 0.2$ V _{PP}	1.5 to 5		-0.7		dB

5. Guaranteed by characterization.

FSA646A

HIGH-SPEED-RELATED AC ELECTRICAL CHARACTERISTICS

Symbol	Parameter	Conditions	V _{CC} (V)	T _A = -40 to +85°C			Unit
				Min.	Typ.	Max.	
t _{SK(P)}	HS Mode Skew of Opposite Transitions of the Same Output (Note 6)	R _L = 50 Ω, C _L = 0 pF, V _{SW} = 0.3 V	1.5 to 5		6		ps
t _{SK(O)}	HS Mode Skew of Channel-to-Channel Single-Ended Skew (Note 6)	R _L = 50 Ω, C _L = 0 pF, V _{SW} = 0.3 V	1.5 to 5		6		ps

6. Guaranteed by characterization.

CAPACITANCE

Symbol	Parameter	Conditions	T _A = -40 to +85°C			Unit
			Min.	Typ.	Max.	
C _{IN}	Control Pin Input Capacitance (Note 7)	V _{CC} = 0 V, f = 1 MHz		2.1		pF
C _{ON}	On Capacitance (Note 7)	V _{CC} = 3.3 V, /OE = 0 V, f = 2250 MHz (in HS common value)		1.4		
C _{OFF}	On Capacitance (Note 7)	V _{CC} and /OE = 3.3 V, f = 2250 MHz (both sides in HS common value)		0.9		

7. Guaranteed by characterization.

The table below pertains to the Packaging information on the following page.

ORDERING INFORMATION

Part Number	Top Mark ^{ing}	Temperature Range	Package
FSA646AUCX	GQ	-40 to +85°C	36-Ball WLCSP, Non-JEDEC 2.43 x 2.43 mm, 0.4 mm Pitch

MECHANICAL CASE OUTLINE

PACKAGE DIMENSIONS

ON Semiconductor®



WLCSP36 2.43x2.43x0.599
CASE 567XH
ISSUE O

DATE 12 FEB 2019

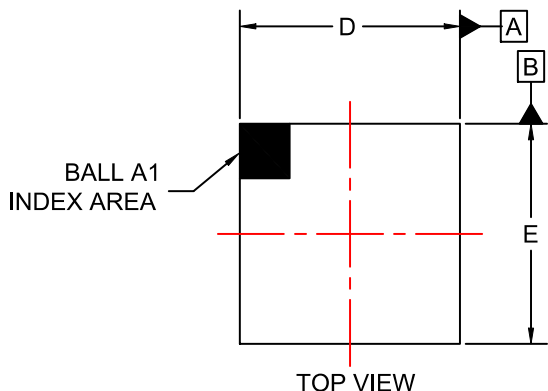

TOP VIEW

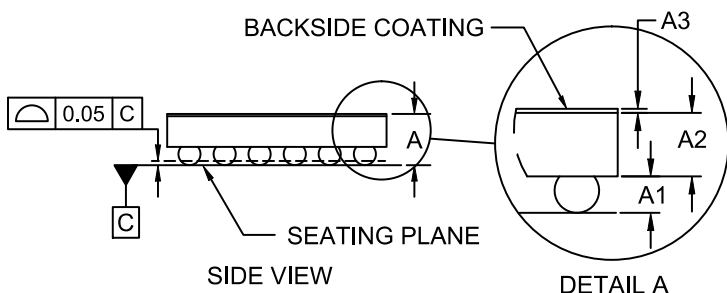

SIDE VIEW

DETAIL A

NOTES:

1. DIMENSIONING AND TOLERANCING PER ASME Y14.5M, 2009.
2. CONTROLLING DIMENSION: MILLIMETERS
3. DATUM C APPLIES TO THE SPHERICAL CROWN OF THE SOLDER BALLS

DIM	MILLIMETERS		
	MIN.	NOM.	MAX.
A	0.558	0.599	0.640
A1	0.174	0.194	0.214
A2	0.362	0.380	0.398
A3	0.022	0.025	0.028
b	0.240	0.260	0.280
D	2.400	2.430	2.460
E	2.400	2.430	2.460
e	0.40 BSC		
x	0.200	0.215	0.230
y	0.200	0.215	0.230

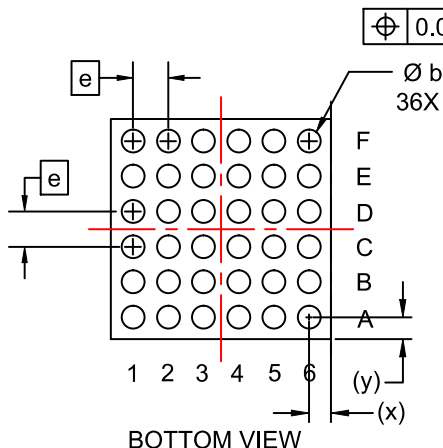

BOTTOM VIEW

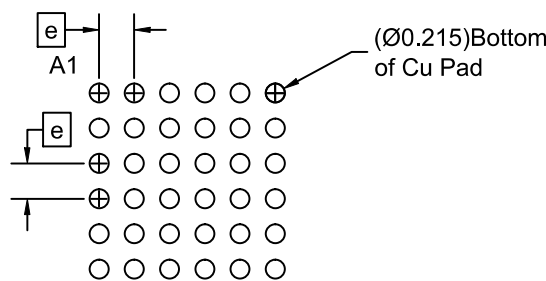

RECOMMENDED MOUNTING FOOTPRINT (NSMD PAD TYPE)

DOCUMENT NUMBER:	98AON99390G	Electronic versions are uncontrolled except when accessed directly from the Document Repository. Printed versions are uncontrolled except when stamped "CONTROLLED COPY" in red.
DESCRIPTION:	WLCSP36 2.43x2.43x0.599	PAGE 1 OF 1

ON Semiconductor and are trademarks of Semiconductor Components Industries, LLC dba ON Semiconductor or its subsidiaries in the United States and/or other countries. ON Semiconductor reserves the right to make changes without further notice to any products herein. ON Semiconductor makes no warranty, representation or guarantee regarding the suitability of its products for any particular purpose, nor does ON Semiconductor assume any liability arising out of the application or use of any product or circuit, and specifically disclaims any and all liability, including without limitation special, consequential or incidental damages. ON Semiconductor does not convey any license under its patent rights nor the rights of others.

onsemi, **Onsemi**, and other names, marks, and brands are registered and/or common law trademarks of Semiconductor Components Industries, LLC dba "**onsemi**" or its affiliates and/or subsidiaries in the United States and/or other countries. **onsemi** owns the rights to a number of patents, trademarks, copyrights, trade secrets, and other intellectual property. A listing of **onsemi**'s product/patent coverage may be accessed at www.onsemi.com/site/pdf/Patent-Marking.pdf. **onsemi** reserves the right to make changes at any time to any products or information herein, without notice. The information herein is provided "as-is" and **onsemi** makes no warranty, representation or guarantee regarding the accuracy of the information, product features, availability, functionality, or suitability of its products for any particular purpose, nor does **onsemi** assume any liability arising out of the application or use of any product or circuit, and specifically disclaims any and all liability, including without limitation special, consequential or incidental damages. Buyer is responsible for its products and applications using **onsemi** products, including compliance with all laws, regulations and safety requirements or standards, regardless of any support or applications information provided by **onsemi**. "Typical" parameters which may be provided in **onsemi** data sheets and/or specifications can and do vary in different applications and actual performance may vary over time. All operating parameters, including "Typicals" must be validated for each customer application by customer's technical experts. **onsemi** does not convey any license under any of its intellectual property rights nor the rights of others. **onsemi** products are not designed, intended, or authorized for use as a critical component in life support systems or any FDA Class 3 medical devices or medical devices with a same or similar classification in a foreign jurisdiction or any devices intended for implantation in the human body. Should Buyer purchase or use **onsemi** products for any such unintended or unauthorized application, Buyer shall indemnify and hold **onsemi** and its officers, employees, subsidiaries, affiliates, and distributors harmless against all claims, costs, damages, and expenses, and reasonable attorney fees arising out of, directly or indirectly, any claim of personal injury or death associated with such unintended or unauthorized use, even if such claim alleges that **onsemi** was negligent regarding the design or manufacture of the part. **onsemi** is an Equal Opportunity/Affirmative Action Employer. This literature is subject to all applicable copyright laws and is not for resale in any manner.

ADDITIONAL INFORMATION

TECHNICAL PUBLICATIONS:

Technical Library: www.onsemi.com/design/resources/technical-documentation
onsemi Website: www.onsemi.com

ONLINE SUPPORT: www.onsemi.com/support

For additional information, please contact your local Sales Representative at www.onsemi.com/support/sales