

# 3.3 V, Crystal to 100 MHz / 125 MHz Quad HCSL / LVDS Clock Generator

## NB3N51044

The NB3N51044 is a precision, low phase noise clock generator that supports PCI Express and sRIO clock requirements. The device accepts a 25 MHz fundamental mode parallel resonant crystal or a 25 MHz single ended reference clock signal and generates four differential HCSL/LVDS outputs (See Figure 10 for LVDS interface) of 100 MHz or 125 MHz clock frequency based on frequency select input F\_SEL. NB3N51044 is configurable to bypass the PLL from signal path using BYPASS, and provides the output frequency through the divider network. All clock outputs can be individually enabled / disabled through hardware input pins OE[3:0]. In addition, device can be reset using Master Reset input pin MR\_OE#.

### Features

- Uses 25 MHz Fundamental Crystal or Reference Clock Input
- Four Low Skew HCSL or LVDS Outputs
- Output Frequency Selection of 100 MHz or 125 MHz
- Individual OE Tri–States Outputs
- Master Reset and BYPASS Modes
- PCIe Gen 1, Gen 2, Gen 3, Gen 4 Compliant
- Typical Phase Jitter @ 125 MHz (Integrated 1.875 MHz to 20 MHz): 0.2 ps
- Typical Cycle–Cycle Jitter @ 100 MHz (10k cycles): 20 ps
- Phase Noise @ 100 MHz:
 

Offset	Noise Power
100 Hz	–101 dBc/Hz
1 kHz	–123 dBc/Hz
10 kHz	–133 dBc/Hz
100 kHz	–136 dBc/Hz
1 MHz	–141 dBc/Hz
10 MHz	–155 dBc/Hz
- Operating Supply Voltage Range 3.3 V  $\pm$ 5%
- Industrial Temperature Range –40°C to +85°C
- Functionally Compatible with ICS841604I with enhanced performance
- These are Pb–Free Devices

### Applications

- Networking
- Consumer
- Computing and Peripherals
- Industrial Equipment
- PCIe Clock Generation Gen 1, Gen 2, Gen 3 and Gen 4

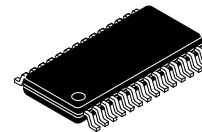

TSSOP–28  
 DT SUFFIX  
 CASE 948AA

### MARKING DIAGRAM

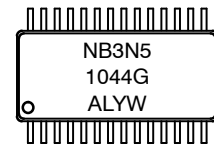

- A = Assembly Location
- L = Wafer Lot
- Y = Year
- W = Work Week
- G = Pb–Free Package

### ORDERING INFORMATION

See detailed ordering and shipping information on page 12 of this data sheet.

### End Products

- Switch and Router
- Set Top Box, LCD TV
- Servers, Desktop Computers
- Automated Test Equipment

# NB3N51044

## BLOCK DIAGRAM

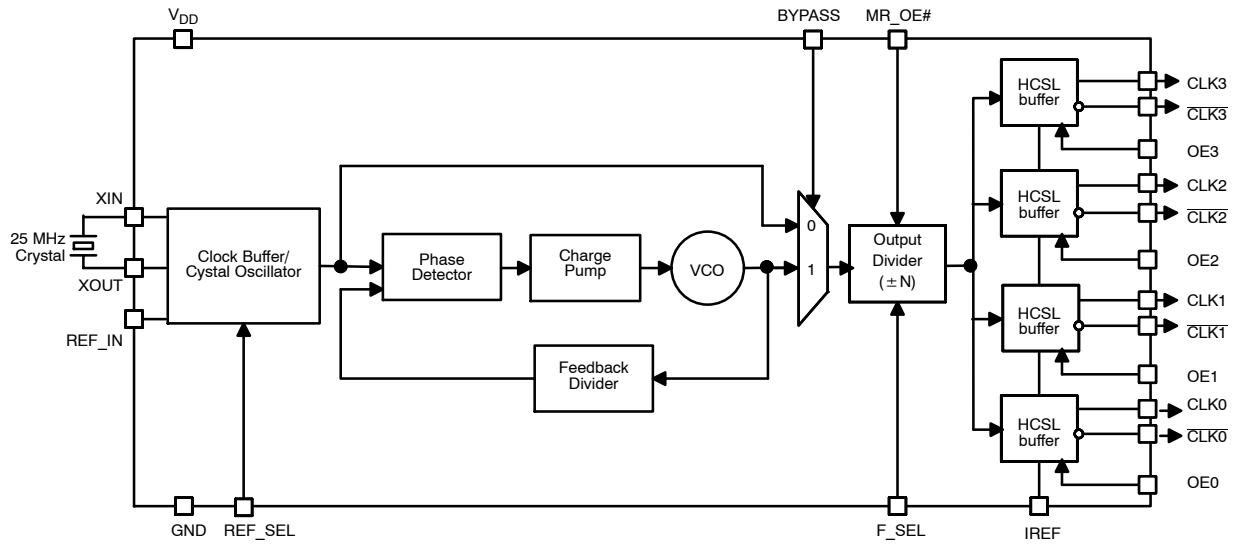

Figure 1. Block Diagram

## PIN CONFIGURATION

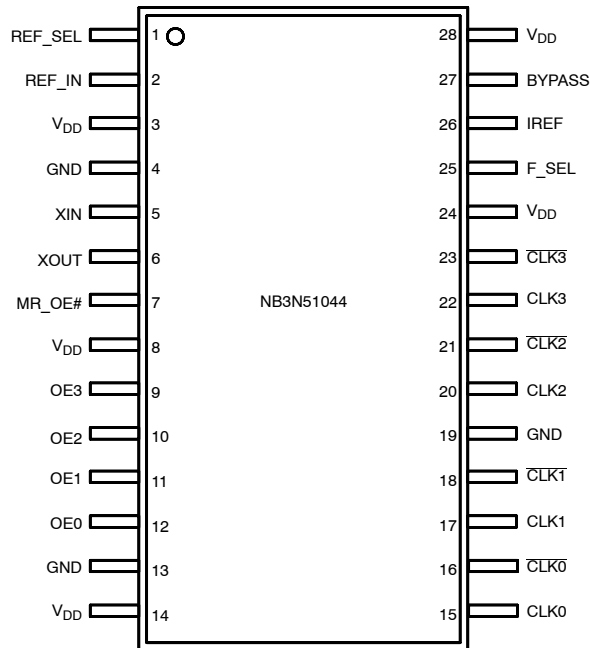

Figure 2. Pin Configuration (Top View)

# NB3N51044

## PIN DESCRIPTION

**Table 1. PIN DESCRIPTION**

Pin #	Pin Name	Type	Description
1	REF_SEL	Input	LVC MOS/ LVTTTL level input to select input reference source. Pulldown with crystal as default reference input source.
2	REF_IN	Input	25 MHz single-ended reference input clock.
3	V <sub>DD</sub>	Power	Positive supply voltage pin connected to +3.3 V typical supply voltage.
4	GND	Ground	Power supply ground 0 V. This pin provides GND return path for the device.
5	XIN	Input	25 MHz fundamental mode crystal input connection. Ground this pin when crystal not connected.
6	XOUT	Output	25 MHz crystal output. Float this pin when crystal not connected.
7	MR_OE#	Input	Asynchronous LVC MOS/ LVTTTL level input. When High, this pin acts as Master Reset to disable the output dividers and set outputs to high impedance (Hi-Z) mode. When Low, this pin acts as Output Enable for enabling the output buffers. Pulldown with default Low.
8	V <sub>DD</sub>	Power	Positive supply voltage pin connected to +3.3 V typical supply voltage.
9	OE3	Input	LVC MOS/ LVTTTL level interface active High output enable pin for CLK3. Pulldown with default Low and output disabled.
10	OE2	Input	LVC MOS/ LVTTTL level interface active High output enable pin for CLK2. Pulldown with default Low and output disabled.
11	OE1	Input	LVC MOS/ LVTTTL level interface active High output enable pin for CLK1. Pulldown with default Low and output disabled.
12	OE0	Input	LVC MOS/ LVTTTL level interface active High output enable pin for CLK0. Pulldown with default Low and output disabled.
13	GND	Ground	Power supply ground 0 V. This pin provides GND return path for the device.
14	V <sub>DD</sub>	Power	Positive supply voltage pin connected to +3.3 V typical supply voltage.
15	CLK0	HCSL or LVDS output	Noninverted clock output. (For LVDS levels see Figure 10)
16	$\overline{\text{CLK0}}$	HCSL or LVDS output	Inverted clock output. (For LVDS levels see Figure 10)
17	CLK1	HCSL or LVDS output	Noninverted clock output. (For LVDS levels see Figure 10)
18	$\overline{\text{CLK1}}$	HCSL or LVDS output	Inverted clock output. (For LVDS levels see Figure 10)
19	GND	Ground	Power supply ground 0 V. This pin provides GND return path for the device.
20	CLK2	HCSL or LVDS output	Noninverted clock output. (For LVDS levels see Figure 10)
21	$\overline{\text{CLK2}}$	HCSL or LVDS output	Inverted clock output. (For LVDS levels see Figure 10)
22	CLK3	HCSL or LVDS output	Noninverted clock output. (For LVDS levels see Figure 10)
23	$\overline{\text{CLK3}}$	HCSL or LVDS output	Inverted clock output. (For LVDS levels see Figure 10)
24	V <sub>DD</sub>	Power	Positive supply voltage pin connected to +3.3 V typical supply voltage.
25	F_SEL	Input	LVC MOS/ LVTTTL level Frequency Selects PCIe (100 MHz) when Low or sRIO (125 MHz) output frequency when High. Pulldown with default of 100 MHz at outputs.
26	IREF	Output	Output current reference pin. Connect to precision resistor (typical 475 Ω) to set internal current reference
27	BYPASS	Input	LVC MOS/ LVTTTL level input. Selects PLL operation mode when Low or PLL bypass mode when High. Pulldown with default of PLL mode.
28	V <sub>DD</sub>	Power	Positive supply voltage pin connected to +3.3 V typical supply voltage.

**Table 2. OUTPUT FREQUENCY SELECT FUNCTION TABLE**

Input		Output
F_SEL	N (Output divider)	CLK[3:0]/CLK[3:0]#
0	5	100MHz (PCIe, default)
1	4	125MHz (sRIO)

**Table 3. PLL BYPASS FUNCTION TABLE**

BYPASS	PLL Configuration
0	PLL Enabled (default)
1	PLL bypassed, $f_{out} = f_{IN}/N$

**Table 4. MASTER RESET AND OE FUNCTION TABLE**

MR_OE#	OEx [x=3:0]	Function
0 (default)	0 (default)	CLKx, CLKx# are High impedance
	1	CLKx Output Enabled
1	x	Device reset, outputs disabled (Hi-Z)

**Table 6. ATTRIBUTES**

Characteristic	Value
ESD Protection Human Body Model	2 kV
Internal Input Default State Resistor	51 kΩ
Moisture Sensitivity, Indefinite Time Out of Dray Pack (Note 1)	Level 1
Flammability Rating Oxygen Index: 28 to 34	UL 94 V-0 @ 0.125 in
Transistor Count	132,000
Meets or exceeds JEDEC Spec EIA/JESD78 IC Latchup Test	

1. For additional information, see Application Note AND8003/D.

**Table 7. ABSOLUTE MAXIMUM RATING (Note 2)**

Symbol	Parameter	Rating	Unit
V <sub>DD</sub>	Positive power supply with respect to GND	+4.6	V
V <sub>I</sub>	Input Voltage with respect to device GND	-0.5 V to V <sub>DD</sub> + 0.5 V	V
T <sub>A</sub>	Operating Temperature Range	-40 to +85	°C
T <sub>STG</sub>	Storage temperature	-65 to +150	°C
T <sub>SOL</sub>	Max. Soldering Temperature (10 sec)	265	°C
θ <sub>JA</sub>	Thermal Resistance (Junction-to-ambient) 0 lfpm (Note 3) 500 lfpm	63 55	°C/W
θ <sub>JC</sub>	Thermal Resistance (Junction-to-case)	50	°C/W

Stresses exceeding those listed in the Maximum Ratings table may damage the device. If any of these limits are exceeded, device functionality should not be assumed, damage may occur and reliability may be affected.

- Maximum ratings applied to the device are individual stress limit values (not normal operating conditions) and not valid simultaneously. If stress limits are exceeded device functional operation is not implied, damage may occur and reliability may be affected.
- JEDEC standard multilayer board – 2S2P (2 signal, 2 power).

**Table 5. INPUT REFERENCE SELECT FUNCTION TABLE**

REF_SEL	Input Reference
0	Crystal, at XIN and XOUT (default)
1	Single-ended reference clock at REF_IN

**Recommended Crystal Parameters**

Crystal	Fundamental AT-Cut
Frequency	25 MHz
Load Capacitance	16–20 pF
Shunt Capacitance, C <sub>0</sub>	7 pF Max
Equivalent Series Resistance	50 Ω Max
Initial Accuracy at 25°C	±20 ppm
Temperature Stability	±30 ppm
Aging	±20 ppm

# NB3N51044

**Table 8. DC ELECTRICAL CHARACTERISTICS** ( $V_{DD} = 3.3 \text{ V} \pm 5\%$ ,  $GND = 0 \text{ V}$ ,  $T_A = -40^\circ\text{C}$  to  $85^\circ\text{C}$ , Note 4)

Symbol	Parameter	Min	Typ	Max	Unit
$V_{DD}$	Power Supply Voltage	3.135	3.3	3.465	V
$I_{DD}$	Power Supply Current when all outputs are ON, $OE[3:0] = 1$ , $F_{CLKOUT} = 125 \text{ MHz}$			126	mA
$I_{OFF}$	Power Supply Current when all outputs are set OFF, $OE[3:0] = 0$		45	50	mA
$V_{IH}$	Input HIGH Voltage (XIN, REF_IN, REF_SEL, BYPASS, F_SEL, MR_OE#)	2.0		$V_{DD}+0.3$	V
$V_{IL}$	Input LOW Voltage (XIN, REF_IN, REF_SEL, BYPASS, F_SEL, MR_OE#)	$GND-0.3$		0.8	V
$I_{IH}$	Input Leakage on logic High current at all input pins			150	$\mu\text{A}$
$I_{IL}$	Input Leakage on logic Low current at all input pins	-5			$\mu\text{A}$
$V_{OH}$	Output HIGH Voltage for HCSL output (Note 5)	660		850	mV
$V_{OL}$	Output LOW Voltage for HCSL output (Note 5)	-150			mV
$V_{MAX}$	Absolute Maximum Voltage, Measured Single ended including overshoot (Notes 5, 6)			1150	mV
$V_{MIN}$	Absolute Minimum Voltage, Measured Single ended including undershoot (Notes 5, 7)	-300			mV
$V_{CROSS}$	Crossing Voltage Magnitude (Absolute) for HCSL output (Notes 5, 8, 9)	250		550	mV
$\Delta V_{CROSS}$	Change in Magnitude of $V_{cross}$ for HCSL Output (Notes 5, 8, 10)			150	mV
$V_{RB}$	Ring Back Voltage measured differentially (Note 11)	-100		100	mV

NOTE: Device will meet the specifications after thermal equilibrium has been established when mounted in a test socket or printed circuit board with maintained transverse airflow greater than 500 lfm.

4. Measurement taken with outputs terminated with  $R_S = 33.2 \Omega$ ,  $R_L = 49.9 \Omega$ , with test load capacitance of 2 pF and current biasing resistor set at  $R_{REF} = 475 \Omega$ . See Figure 9. Guaranteed by characterization.
5. Measurement taken from single-ended waveform
6. Defined as the maximum instantaneous voltage value including positive overshoot
7. Defined as the maximum instantaneous voltage value including negative overshoot
8. Measured at crossing point where the instantaneous voltage value of the rising edge of  $CLKx+$  equals the falling edge of  $CLKx-$ .
9. Refers to the total variation from the lowest crossing point to the highest, regardless of which edge is crossing. Refers to all crossing points for this measurement.
10. Defined as the total variation of all crossing voltage of rising  $CLKx+$  and falling  $CLKx-$ . This is maximum allowed variance in the  $V_{CROSS}$  for any particular system.
11. Differential clock must maintain a minimum  $\pm 150 \text{ mV}$  differential voltage after rising/falling edges before it is allowed to drop back into the  $V_{RB} \pm 100$  differential range.

# NB3N51044

**Table 9. AC ELECTRICAL CHARACTERISTICS** ( $V_{DD} = 3.3 \text{ V} \pm 5\%$ ,  $GND = 0 \text{ V}$ ,  $T_A = -40^\circ\text{C}$  to  $85^\circ\text{C}$ , Note 12)

Symbol	Parameter	Conditions	Min	Typ	Max	Unit
$f_{CLKIN}$	Clock/ Crystal input frequency			25		MHz
$f_{CLKOUT}$	Output Frequency			100 / 125		MHz
$\Phi_{NOISE-100M}$	Phase Noise Performance at 100 MHz	@ 100 Hz offset from carrier		-101		dBc/Hz
		@ 1 kHz offset from carrier		-123		
		@ 10 kHz offset from carrier		-133		
		@ 100 kHz offset from carrier		-136		
		@ 1 MHz offset from carrier		-141		
		@ 10 MHz offset from carrier		-155		
$\Phi_{NOISE-125M}$	Phase Noise Performance at 125 MHz	@ 100 Hz offset from carrier		-98		dBc/Hz
		@ 1 kHz offset from carrier		-117		
		@ 10 kHz offset from carrier		-130		
		@ 100 kHz offset from carrier		-133		
		@ 1 MHz offset from carrier		-141		
		@ 10 MHz offset from carrier		-154		
$t_{JIT(\Phi)-100M}$	RMS Phase Jitter at 100 MHz Clock	Integration Range 1.875 MHz to 20 MHz		0.2		ps
		Integration Range 12 kHz to 20 MHz		0.4		
$t_{JIT(\Phi)-125M}$	RMS Phase Jitter at 125 MHz Clock	Integration Range 1.875 MHz to 20 MHz		0.2		ps
		Integration Range 12 kHz to 20 MHz		0.4		
$t_{JITTER-100M}$	Peak Cycle-to-Cycle Jitter	Measured at 100 MHz over 10000 cycles		20		ps
$t_{JITTER-125M}$	Peak Cycle-to-Cycle Jitter	Measured at 100 MHz over 10000 cycles		20		ps
$t_R / t_F$	Rise / Fall Time @ 100 MHz and 125 MHz	Measured differentially between -150 mV to 150 mV with 2 pF Load, Figure 11	0.6		4.0	V/ns
$\Delta t_R / t_F$	Output Rise/ Fall time variation				125	ps
$t_{SKEW}$	Within device output to output skew				40	ps
$t_{OE}$	Output enable/disable time (Note 13)	Measured at cross point		10		$\mu\text{s}$
$t_{DC}$	Output Clock Duty Cycle	$V_{DD} = 3.3 \text{ V}$	45	50	55	%
$t_{PU}$	Stabilization time from Power-up			3.0		mS

NOTE: Device will meet the specifications after thermal equilibrium has been established when mounted in a test socket or printed circuit board with maintained transverse airflow greater than 500 lpm.

12. Measurement taken from differential output on single-ended channel terminated with  $R_S = 33.2 \Omega$ ,  $R_L = 49.9 \Omega$ , with test load capacitance of 2 pF and current biasing resistor set at  $R_{REF} = 475 \Omega$ . See Figure 9. Guaranteed by characterization.

13. Output pins are tri-stated when OE is asserted LOW. Output pins are driven differentially when OE is HIGH unless device is in power down mode,  $\overline{PD} = \text{Low}$ .

**Table 10. AC ELECTRICAL CHARACTERISTICS – PCI EXPRESS JITTER SPECIFICATIONS**

$V_{DD} = 3.3\text{ V} \pm 5\%$ ,  $T_A = -40^\circ\text{C}$  to  $85^\circ\text{C}$ ,  $f_{OUT} = 100\text{ MHz}$ ,  $125\text{ MHz}$

Symbol	Parameter	Test Condition	Min	Typ	Max	PCIe Industry Spec	Unit
$t_j$ (PCIe Gen 1)	Phase Jitter Peak-to-Peak (Notes 15 and 18)	$f_{CLKIN} = 25\text{ MHz}$ Crystal, $f_{CLKOUT} = 100\text{ MHz}$ Input Evaluation Band: 0 Hz – Nyquist (clock frequency/2) for $10^6$ clock periods		10	20	86	ps
		$f_{CLKIN} = 25\text{ MHz}$ Crystal, $f_{CLKOUT} = 125\text{ MHz}$ Input Evaluation Band: 0 Hz – Nyquist (clock frequency/2) for $10^6$ clock periods		10	20	–	
$t_{REFCLK\_HF\_RMS}$ (PCIe Gen 2)	Phase Jitter RMS (Notes 16 and 18)	$f_{CLKIN} = 25\text{ MHz}$ Crystal, $f_{CLKOUT} = 100\text{ MHz}$ Input High Band: 1.5 MHz – Nyquist (clock frequency/2)		1.0	1.8	3.1	ps
		$f_{CLKIN} = 25\text{ MHz}$ Crystal, $f_{CLKOUT} = 125\text{ MHz}$ Input High Band: 1.5 MHz – Nyquist (clock frequency/2)		0.8	1.0	–	
$t_{REFCLK\_LF\_RMS}$ (PCIe Gen 2)	Phase Jitter RMS (Notes 16 and 18)	$f_{CLKIN} = 25\text{ MHz}$ Crystal, $f_{CLKOUT} = 100\text{ MHz}$ Input Low Band: 10 kHz – 1.5 MHz		0.10	0.15	3.0	ps
		$f_{CLKIN} = 25\text{ MHz}$ Crystal, $f_{CLKOUT} = 125\text{ MHz}$ Input Low Band: 10 kHz – 1.5 MHz		0.08	0.15	–	
$t_{REFCLK\_RMS}$ (PCIe Gen 3)	Phase Jitter RMS (Notes 17 and 18)	$f_{CLKIN} = 25\text{ MHz}$ Crystal, $f_{CLKOUT} = 100\text{ MHz}$ Input Evaluation Band: 0 Hz – Nyquist (clock frequency/2)		0.35	0.70	0.8	ps
		$f_{CLKIN} = 25\text{ MHz}$ Crystal, $f_{CLKOUT} = 125\text{ MHz}$ Input Evaluation Band: 0 Hz – Nyquist (clock frequency/2)		0.17	0.22	–	
$t_{REFCLK\_RMS}$ (PCIe Gen 4)	Phase Jitter RMS (Notes 17 and 18)	$f = 100\text{ MHz}$ , 25 MHz Crystal Input Evaluation Band: 0 Hz – Nyquist (clock frequency/2)	SSOFF	0.35	0.5	0.5	ps

14. Electrical parameters are guaranteed over the specified ambient operating temperature range, which is established when the device is mounted in a test socket with maintained transverse airflow greater than 500 lpm. The device will meet specifications after thermal equilibrium has been reached under these conditions.
15. Peak-to-Peak jitter after applying system transfer function for the Common Clock Architecture. Maximum limit for PCI Express Gen 1 is 86 ps peak-to-peak for a sample size of  $10^6$  clock periods.
16. RMS jitter after applying the two evaluation bands to the two transfer functions defined in the Common Clock Architecture and reporting the worst case results for each evaluation band. Maximum limit for PCI Express Generation 2 is 3.1 ps RMS for  $t_{REFCLK\_HF\_RMS}$  (High Band) and 3.0 ps RMS for  $t_{REFCLK\_LF\_RMS}$  (Low Band).
17. RMS jitter after applying system transfer function for the common clock architecture.
18. Measurement taken from differential output on single-ended channel terminated with  $R_S = 33.2\ \Omega$ ,  $R_L = 49.9\ \Omega$ , with test load capacitance of 2 pF and current biasing resistor set at  $R_{REF} = 475\ \Omega$ . See Figure 9. This parameter is guaranteed by characterization. Not tested in production.

# NB3N51044

## PHASE NOISE

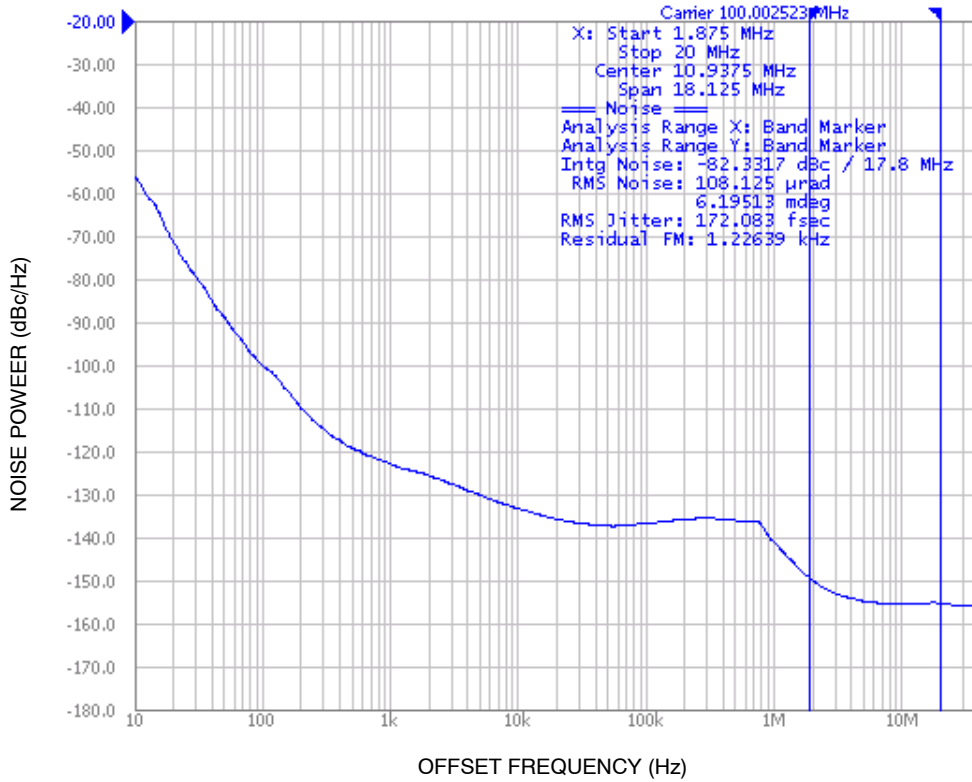

Figure 3. Typical Phase Noise Plot at 100 MHz ( $f_{CLKIN} = 25$  MHz Crystal,  $f_{CLKOUT} = 100$  MHz, RMS Phase Jitter = 172 fs for Integration Range of 1.875 MHz to 20 MHz, Output Termination = HCSL type)

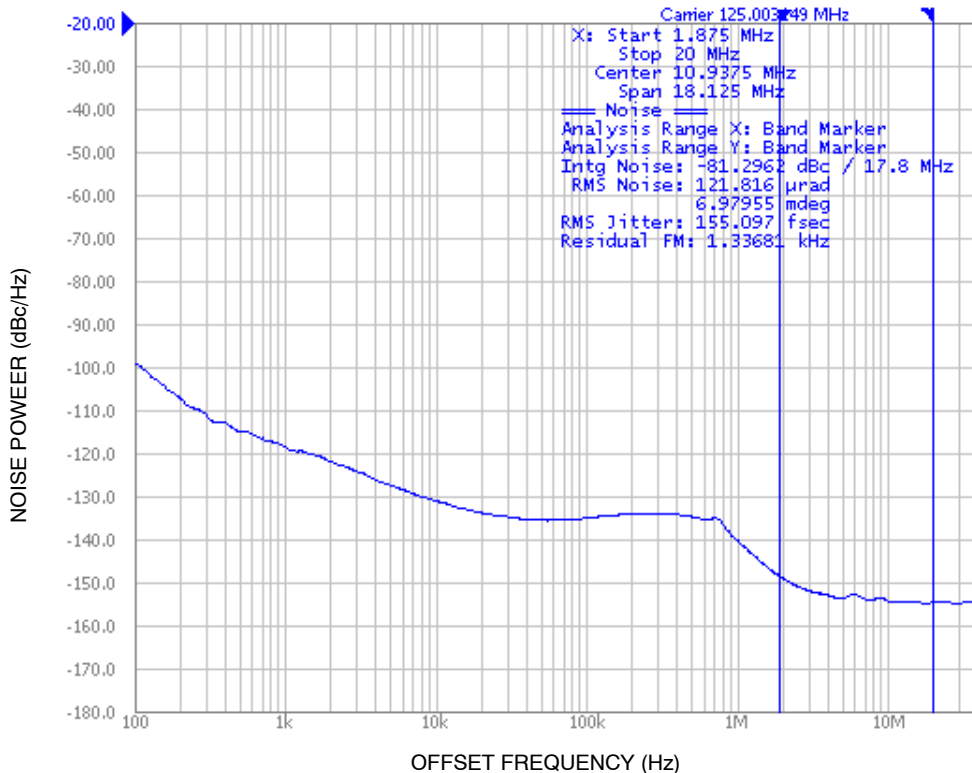

Figure 4. Typical Phase Noise Plot at 125 MHz ( $f_{CLKIN} = 25$  MHz Crystal,  $f_{CLKOUT} = 125$  MHz, RMS Phase Jitter = 155 fs for Integration Range of 1.875 MHz to 20 MHz, Output Termination = HCSL type)



PHASE NOISE

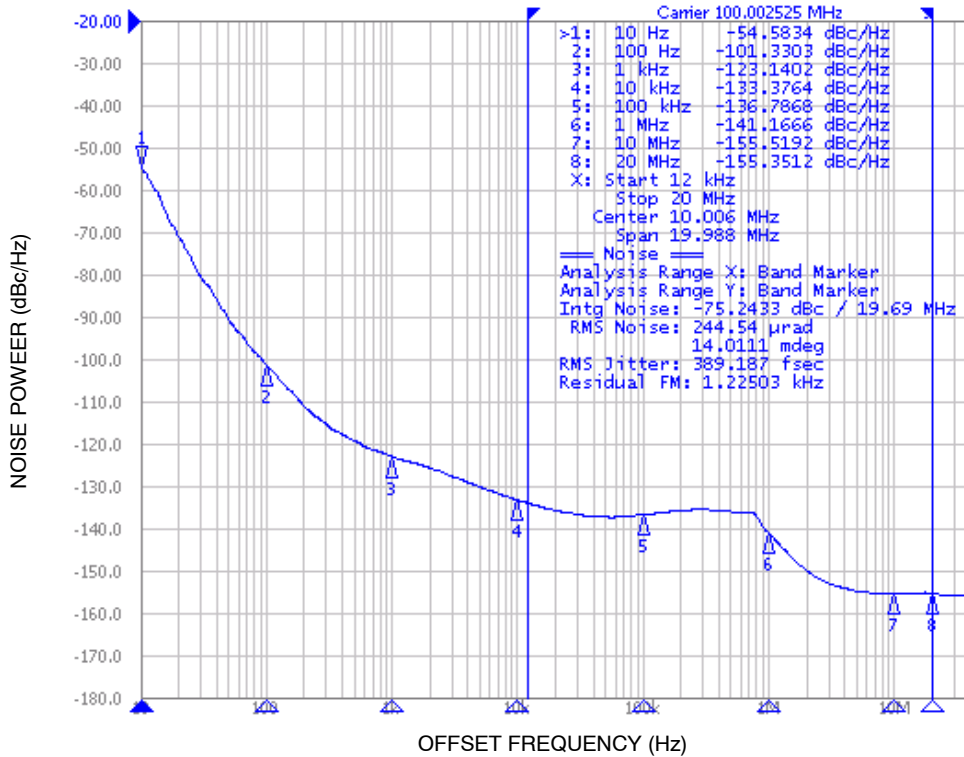

Figure 5. Typical Phase Noise Plot at 100 MHz ( $f_{CLKIN} = 25$  MHz Crystal,  $f_{CLKOUT} = 100$  MHz, RMS Phase Jitter = 389 fs for Integration Range of 12 kHz to 20 MHz, Output Termination = HCSL type)

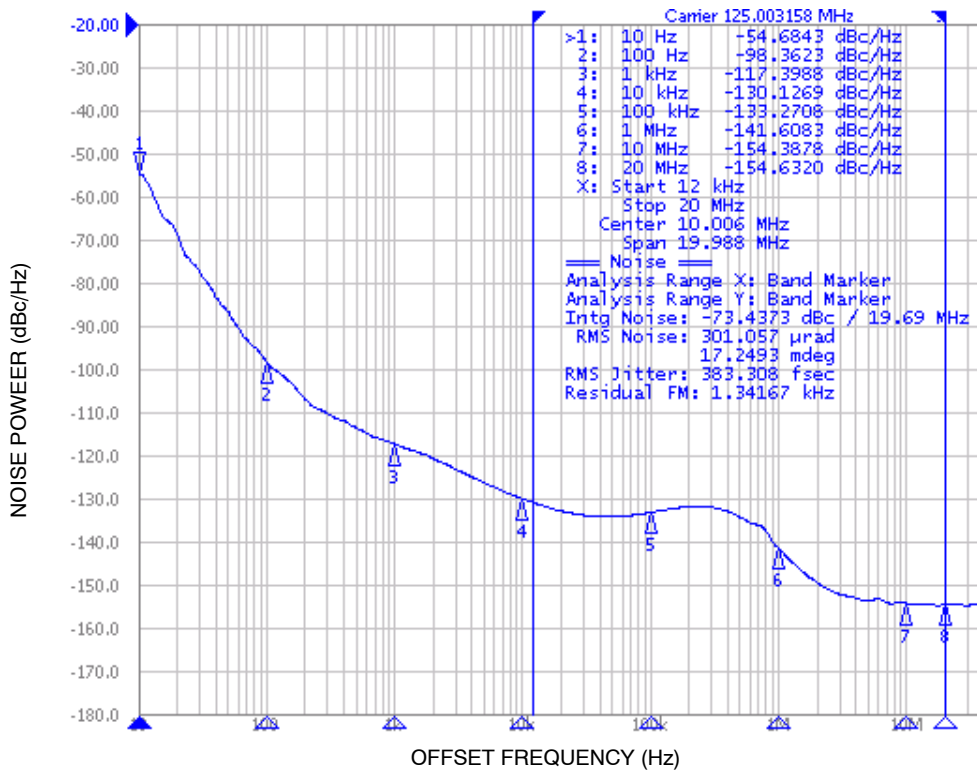

Figure 6. Typical Phase Noise Plot at 125 MHz ( $f_{CLKIN} = 25$  MHz Crystal,  $f_{CLKOUT} = 125$  MHz, RMS Phase Jitter = 383 fs for Integration Range of 12 kHz to 20 MHz, Output Termination = HCSL type)

APPLICATION INFORMATION

**Crystal Input Interface**

Figure 7 shows the NB3N51044 device crystal oscillator interface using a typical parallel resonant crystal. The device crystal connections should include pads for small capacitors from X1 to ground and from X2 to ground. These capacitors,  $C_1$  and  $C_2$ , need to consider the stray capacitances of the board and are used to match the nominally required crystal load capacitance  $C_L$ . A parallel crystal with loading capacitance  $C_L = 18 \text{ pF}$  would use  $C_1 = 26 \text{ pF}$  and  $C_2 = 26 \text{ pF}$

as nominal values, assuming approximately 2 pF of stray capacitance per trace and approximately 8 pF of internal capacitance.

$$C_L = (C_1 + C_{\text{stray}} + C_{\text{in}}) / 2; C_1 = C_2$$

The frequency accuracy and duty cycle skew can be fine-tuned by adjusting the  $C_1$  and  $C_2$  values. For example, increasing the  $C_1$  and  $C_2$  values will reduce the operational frequency.

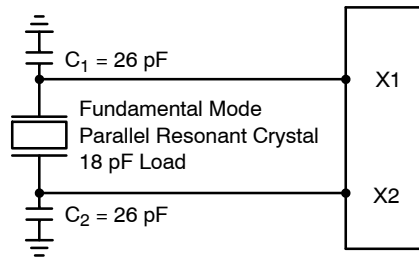

Figure 7. Crystal Interface Loading

**Power Supply Filter**

In order to isolate the NB3N51044 from system power supply, noise decoupling is required. The 10  $\mu\text{F}$  and a 0.1  $\mu\text{F}$  cap from supply pins to GND decoupling capacitor has to be connected between  $V_{DD}$  (pins 3, 8, 14, 24 and 28) and GND (pins 4, 13 and 19). It is recommended to place decoupling

capacitors as close as possible to the device to minimize lead inductance.

**Termination**

The output buffer structure is shown in the Figure 8.

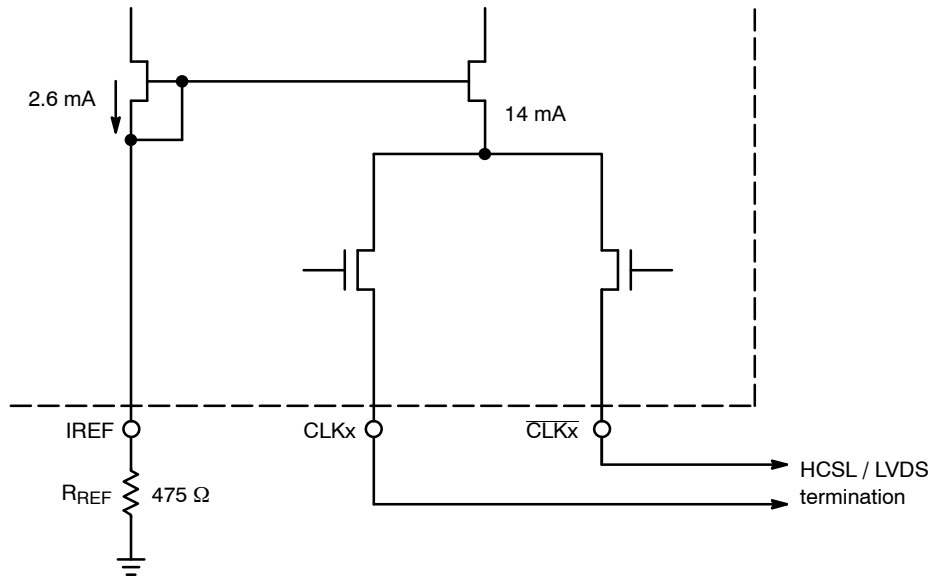

Figure 8. Simplified Output Structure

## NB3N51044

The outputs can be terminated to drive HCSL receiver (see Figure 9) or LVDS receiver (see Figure 10). HCSL output interface requires  $49.9\ \Omega$  termination resistors to GND for generating the output levels. LVDS output

interface may not require the  $100\ \Omega$  near the LVDS receiver if the receiver has internal  $100\ \Omega$  termination. An optional series resistor  $R_L$  may be connected to reduce the overshoots in case of impedance mismatch.

### HCSL INTERFACE

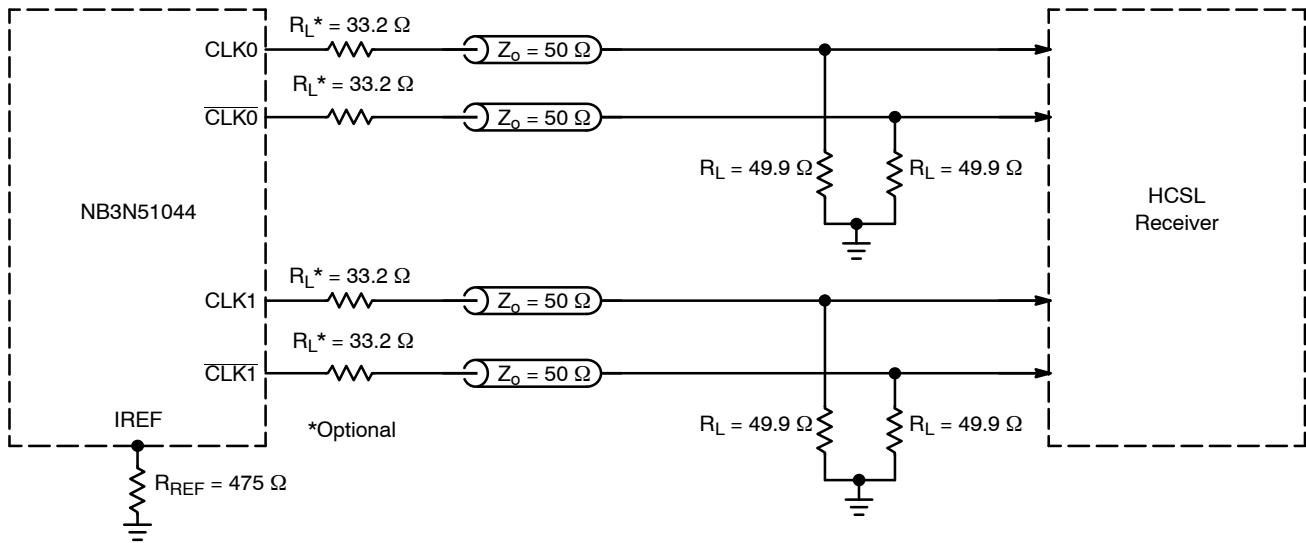

Figure 9. Typical Termination for HCSL Output Driver and Device Evaluation

### LVDS COMPATIBLE INTERFACE

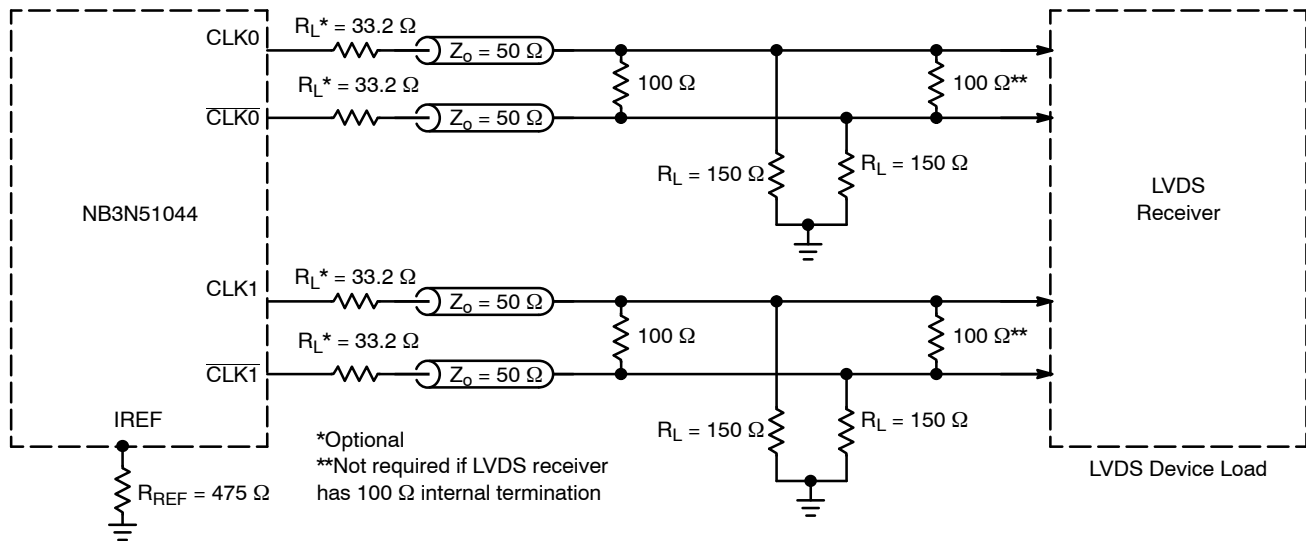

Figure 10. Typical Termination for LVDS Device Load

# NB3N51044

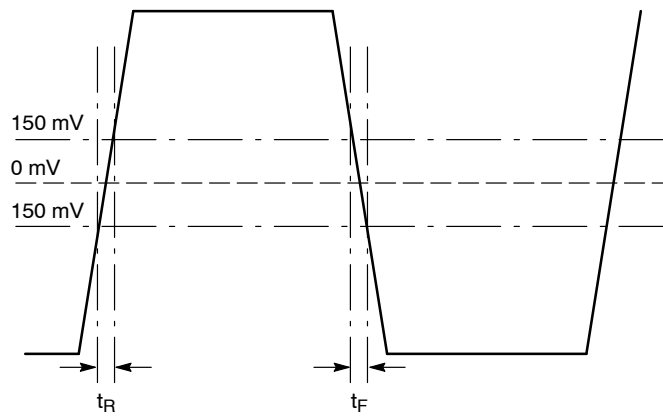

Figure 11. HCSL Differential Measurement of  $t_R/t_F$

## ORDERING INFORMATION

Device	Temperature	Package	Shipping†
NB3N51044DTR2G	-40°C to 85°C	TSSOP-28 (Pb-Free)	2500 / Tape & Reel

†For information on tape and reel specifications, including part orientation and tape sizes, please refer to our Tape and Reel Packaging Specifications Brochure, BRD8011/D.



SCALE 1:1

TSSOP28  
CASE 948AA  
ISSUE A

DATE 26 OCT 2011

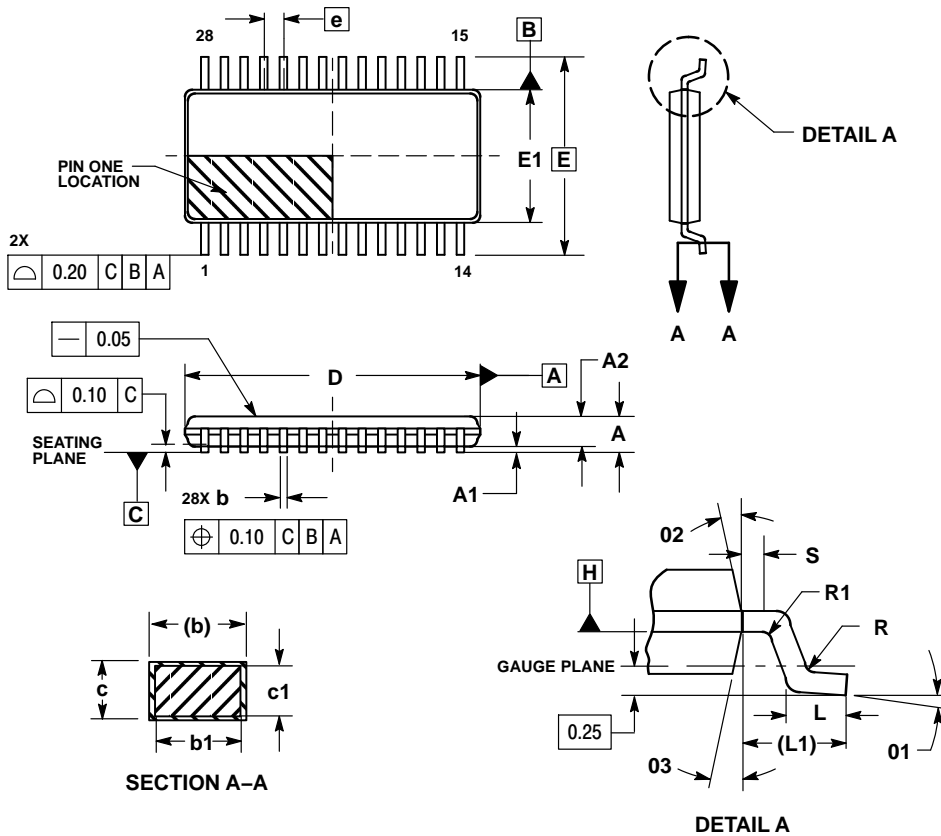

NOTES:

1. DIMENSIONS AND TOLERANCING PER ASME Y14.5M, 1994.
2. DIMENSIONS IN MILLIMETERS.
3. DIMENSION b DOES NOT INCLUDE DAMBAR PROTRUSION. ALLOWABLE DAMBAR PROTRUSION SHALL BE 0.08 MM TOTAL IN EXCESS OF THE "b" DIMENSION AT MAXIMUM MATERIAL CONDITION.
4. DATUMS A AND B TO BE DETERMINED AT DATUM PLANE H.

MILLIMETERS		
DIM	MIN	MAX
A	---	1.20
A1	0.05	0.15
A2	0.80	1.05
b	0.19	0.30
b1	0.19	0.25
c	0.09	0.20
c1	0.09	0.16
D	9.60	9.80
E	6.40	BSC
E1	4.30	4.50
e	0.65	BSC
L	0.45	0.75
L1	1.00	REF
R	0.09	---
R1	0.09	---
S	0.20	---
01	0°	8°
02	12°	REF
03	12°	REF

GENERIC MARKING DIAGRAM\*

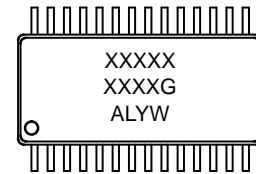

- XXXXX = Specific Device Code
- A = Assembly Location
- L = Wafer Lot
- Y = Year
- W = Work Week
- G = Pb-Free Package

\*This information is generic. Please refer to device data sheet for actual part marking.

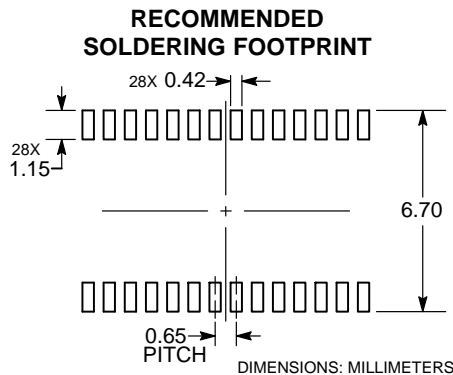

DOCUMENT NUMBER:	98AON13023D	Electronic versions are uncontrolled except when accessed directly from the Document Repository. Printed versions are uncontrolled except when stamped "CONTROLLED COPY" in red.
DESCRIPTION:	28 LEAD TSSOP, 9.7X4.4X1.0 MM, 0.65 PITCH	PAGE 1 OF 1

onsemi and ONSEMI are trademarks of Semiconductor Components Industries, LLC dba onsemi or its subsidiaries in the United States and/or other countries. onsemi reserves the right to make changes without further notice to any products herein. onsemi makes no warranty, representation or guarantee regarding the suitability of its products for any particular purpose, nor does onsemi assume any liability arising out of the application or use of any product or circuit, and specifically disclaims any and all liability, including without limitation special, consequential or incidental damages. onsemi does not convey any license under its patent rights nor the rights of others.

**onsemi**, **Onsemi**, and other names, marks, and brands are registered and/or common law trademarks of Semiconductor Components Industries, LLC dba "**onsemi**" or its affiliates and/or subsidiaries in the United States and/or other countries. **onsemi** owns the rights to a number of patents, trademarks, copyrights, trade secrets, and other intellectual property. A listing of **onsemi**'s product/patent coverage may be accessed at [www.onsemi.com/site/pdf/Patent-Marking.pdf](http://www.onsemi.com/site/pdf/Patent-Marking.pdf). **onsemi** reserves the right to make changes at any time to any products or information herein, without notice. The information herein is provided "as-is" and **onsemi** makes no warranty, representation or guarantee regarding the accuracy of the information, product features, availability, functionality, or suitability of its products for any particular purpose, nor does **onsemi** assume any liability arising out of the application or use of any product or circuit, and specifically disclaims any and all liability, including without limitation special, consequential or incidental damages. Buyer is responsible for its products and applications using **onsemi** products, including compliance with all laws, regulations and safety requirements or standards, regardless of any support or applications information provided by **onsemi**. "Typical" parameters which may be provided in **onsemi** data sheets and/or specifications can and do vary in different applications and actual performance may vary over time. All operating parameters, including "Typicals" must be validated for each customer application by customer's technical experts. **onsemi** does not convey any license under any of its intellectual property rights nor the rights of others. **onsemi** products are not designed, intended, or authorized for use as a critical component in life support systems or any FDA Class 3 medical devices or medical devices with a same or similar classification in a foreign jurisdiction or any devices intended for implantation in the human body. Should Buyer purchase or use **onsemi** products for any such unintended or unauthorized application, Buyer shall indemnify and hold **onsemi** and its officers, employees, subsidiaries, affiliates, and distributors harmless against all claims, costs, damages, and expenses, and reasonable attorney fees arising out of, directly or indirectly, any claim of personal injury or death associated with such unintended or unauthorized use, even if such claim alleges that **onsemi** was negligent regarding the design or manufacture of the part. **onsemi** is an Equal Opportunity/Affirmative Action Employer. This literature is subject to all applicable copyright laws and is not for resale in any manner.

## ADDITIONAL INFORMATION

### TECHNICAL PUBLICATIONS:

Technical Library: [www.onsemi.com/design/resources/technical-documentation](http://www.onsemi.com/design/resources/technical-documentation)  
onsemi Website: [www.onsemi.com](http://www.onsemi.com)

### ONLINE SUPPORT: [www.onsemi.com/support](http://www.onsemi.com/support)

For additional information, please contact your local Sales Representative at [www.onsemi.com/support/sales](http://www.onsemi.com/support/sales)

