

NCN5151

Wired M-BUS Slave Transceiver with Low Power Mode Support

Description

The NCN5151 is a single-chip integrated slave transceiver for use in two-wire Meter Bus (M-BUS) slave devices and repeaters.

The NCN5151 reuses the NCN5150 features and adds two low power modes: a 2-wire low power mode dedicated to System for meter Communication and Readout for powerless meters (SCR) and a 3-wire low power mode allowing support for wireless applications. When configured in low power mode, the transceiver will not behave anymore as a constant current source in order to save energy.

When configured and used in M-BUS mode, the NCN5151 transceiver provides all of the functions needed to satisfy the European Standards EN 13757-2 and EN 1434-3 describing the physical layer requirements for M-BUS. It includes a programmable power level of up to 6 unit loads, which are available for use in external circuits through a 3.3 V LDO regulator.

Features

- Single-chip M-BUS Transceiver
- 2 and 3-Wire Low Power Modes with Selection Input Pins
- Integrated 3.3 V VDD LDO Regulator with Extended Peak Current Capability of 15 mA
- Supports Powering Slave Device from the Bus
- Adjustable Constant Current Sink Up to 6 Unit Loads in M-Bus Mode
- Adjustable Current Limit up to 2 Unit Loads in Low Power Mode
- Current budget of 0.88 mA minimum for external circuits
- Low Turn-ON/OFF Levels for Low Bus Voltage Operation
- Polarity Independent
- Power-Fail Function (M-Bus mode)
- UART Communication Speeds up to 38400 baud
- Fast Startup – No External Transistor Required on STC Pin
- Industrial Ambient Temperature Range of -40°C to +85°C
- These are Pb-free Devices

Typical Applications

- Multi-Energy Utility Meters
 - ◆ Water
 - ◆ Gas
 - ◆ Electricity
 - ◆ Heating systems

Related Standards – European Standard

EN 13757-2, EN 1434-3

For more information visit www.m-bus.com



ON Semiconductor®

www.onsemi.com

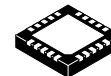

NQFP-20
MN SUFFIX
CASE 485E

MARKING DIAGRAMS

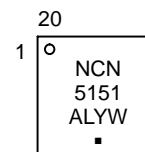

- A = Assembly Location
- L = Wafer Lot (optional)
- Y = Year
- W = Work Week
- = Pb-free Package

ORDERING INFORMATION

See detailed ordering and shipping information on page 19 of this data sheet.

NCN5151

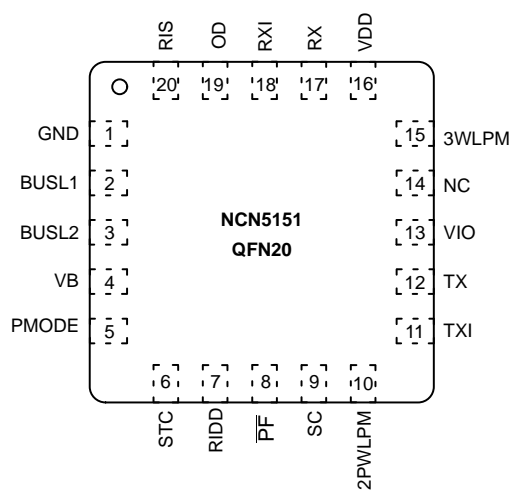

Figure 1. Pin Out NCN5151 in 20-pin NQFP (Top View)

Table 1. NCN5151 PINOUT

| Signal Name | Type | Pin Number | Pin Description |
|-------------|--------|------------|---|
| GND | Ground | 1 | Ground |
| BUSL1 | Bus | 2 | Bus line. Connect to bus through series resistors. Connections are polarity independent. |
| BUSL2 | Bus | 3 | |
| VB | Power | 4 | Rectified bus voltage |
| PMODE | Output | 5 | Power Mode output indicating the voltage level on VB pin |
| STC | Output | 6 | Storage capacitor pin. Connect to bulk storage capacitor (typically 100 μ F – 470 μ F, minimum 10 μ F). |
| RIDD | Input | 7 | Mark current adjustment pin. Connect to programming resistor. |
| PF | Output | 8 | Power Fail, active low (disabled in low power mode) |
| SC | Output | 9 | Mark bus voltage level storage capacitor pin. Connect to ceramic capacitor (typically 220 nF). |
| 2WLPM | Input | 10 | 2-Wire Low Power Mode selection input |
| TXI | Output | 11 | UART Data output (inverted) |
| TX | Output | 12 | UART Data output |
| VIO | Input | 13 | I/O pins (RX, RXI, TX, TXI, PF) high level voltage |
| NC | – | 14 | Leave this pin floating. |
| 3WLPM | Input | 15 | 3-Wire Low Power Mode selection input |
| VDD | Power | 16 | Voltage regulator output. Connect to minimum 1 μ F decoupling capacitor. |
| RX | Input | 17 | UART Data input |
| RXI | Input | 18 | UART Data input (inverted) |
| OD | Output | 19 | Open Drain output (active low). Used for the slave to master communication in 3-Wire Low Power mode |
| RIS | Input | 20 | Modulation current adjustment pin |

NCN5151

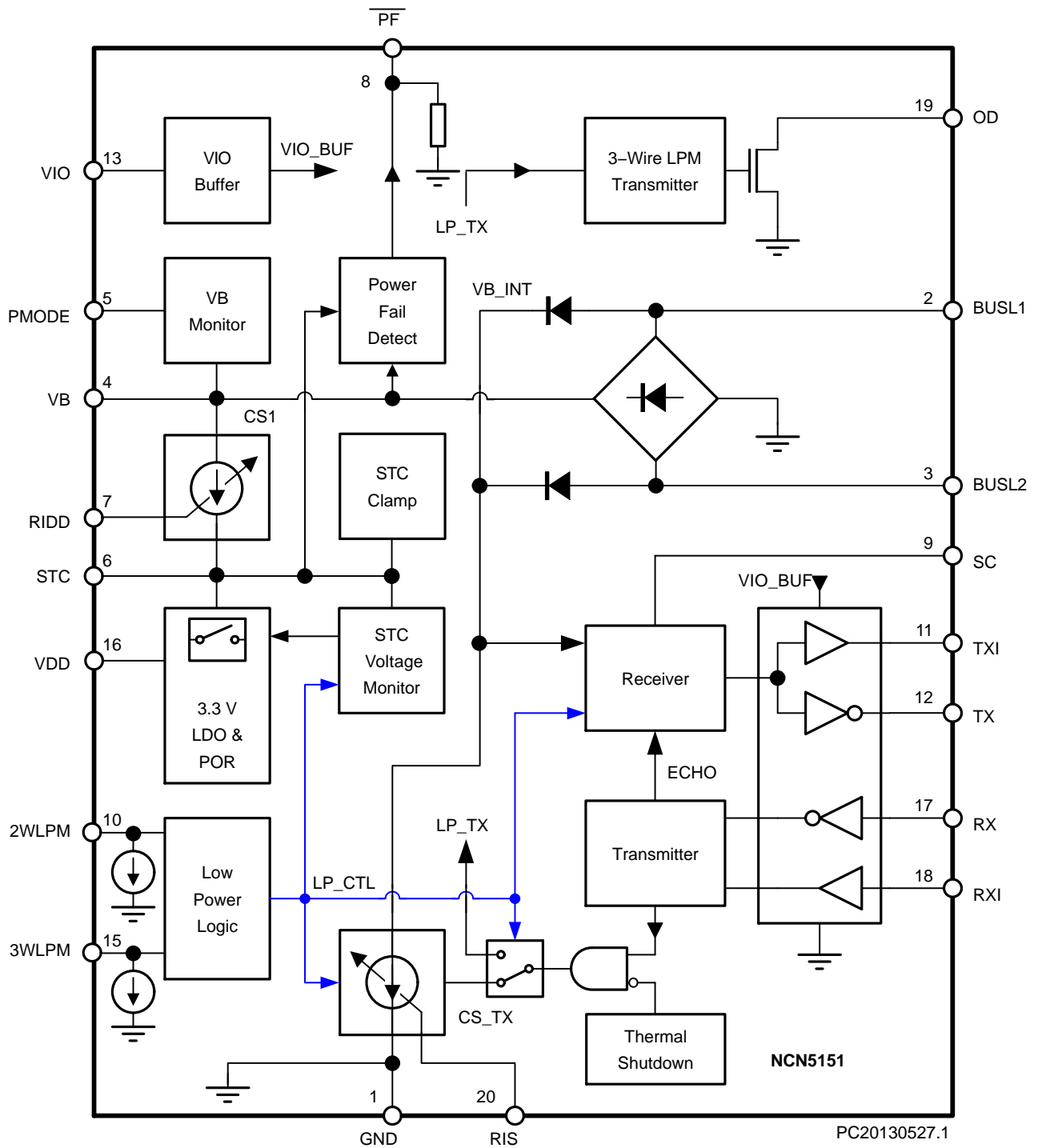

Figure 2. NCN5151 Block Diagram

Table 2. ABSOLUTE MAXIMUM RATINGS

| Symbol | Parameter | Min | Max | Unit |
|--|-----------------------------------|------|------|------|
| T _J | Junction temperature | -40 | +150 | °C |
| T _S | Storage temperature | -55 | +150 | °C |
| V _{BUS} | Bus voltage (BUSL1 – BUSL2) | -50 | 50 | V |
| V _{TX} , V _{TXI} | Voltage on pin TX, TXI | -0.3 | 7.5 | V |
| V _{RX} , V _{RXI} , V _{IO} | Voltage on pin RX, RXI, VIO | -0.3 | 5.5 | V |
| V _{OD} | Voltage on pin OD | -0.3 | 40 | V |
| V _{3WLPM} | Voltage on pin 3WLPM | -0.3 | 3.6 | V |
| V _{2WLPM} | Voltage on pin 2WLPM | -0.3 | 3.6 | V |
| V _{PMODE} | Voltage on pin PMODE | -0.3 | 3.6 | V |
| ESD _{HBM} | ESD Rating – Human Body Model | 4.0 | – | kV |
| ESD _{MM} | ESD Rating – Machine Model | 250 | – | V |
| ESD _{CDM} | ESD Rating – Charged Device Model | 750 | – | V |

Stresses exceeding those listed in the Maximum Ratings table may damage the device. If any of these limits are exceeded, device functionality should not be assumed, damage may occur and reliability may be affected.

1. All voltages are referenced to GND.

Table 3. THERMAL CHARACTERISTICS

| Symbol | Rating | Typical Value | Unit |
|------------------|---|---------------|------|
| R _{θJA} | Thermal Characteristics, QFN-20 Thermal Resistance, Junction-to-Air R _{θJA} obtained with 2S2P test boards according to JEDEC JESD51 standard. | 38 | °C/W |

Table 4. RECOMMENDED OPERATING CONDITIONS (Note 2)

| Symbol | Parameter | | Min | Max | Unit | |
|---------------------|---|------------------------|--------------------|------|------|---|
| T _A | Ambient Temperature | | -40 | +85 | °C | |
| V _{BUS} | Bus voltage (V _{BUSL1} –V _{BUSL2}) | M-Bus mode | 1–2 U _L | 9.2 | 42 | V |
| | | | 3–6 U _L | 9.7 | 42 | V |
| | | 2 and 3–Low Power Mode | 1–2 U _L | 4.75 | 10 | V |
| V _{STC,LP} | VSTC in Low Power Mode to guarantee min V _{DD} of 3.1 V @ I _{DD} = 15 mA peak | | 3.8 | | V | |
| V _{IO} | VIO pin voltage (Note 3) | | 2.5 | 3.8 | V | |
| V _{OD} | OD pin voltage (Note 3) | | 0 | 10 | V | |
| ESD–HBM | Human Body Model (EIA–JESD22–A114–B) | | 4 | | kV | |
| ESD–MM | Machine Model (JEDEC JESD22–A115) | | 200 | | V | |
| ESD–CDM | Charged Device Model (EIA–JESD22–C101–A) | | 750 | | V | |
| LU | Latch-up (EIA/JESD78) | | ±100 | | mA | |

2. Refer to ELECTRICAL CHARACTERISTICS and APPLICATION INFORMATION for Safe Operating Area.

3. All voltages are referenced to GND

NCN5151

Table 5. M-BUS MODE – ELECTRICAL CHARACTERISTICS (Notes 4 and 5)

| Symbol | Parameter | Min | Typ | Max | Unit | |
|------------------------|---|-------------------------------------|------|-----------------|---------------|----|
| ΔV_{BR} | Voltage drop over bus rectifier ($V_{BUS} - V_B$) with $R_{IDD} = 4.02 \text{ k}\Omega$ | | | 1.25 | V | |
| ΔV_{CS} | Voltage drop over CS1 ($V_B - V_{STC}$) | $R_{IDD} \leq 13 \text{ k}\Omega$ | 1.30 | | V | |
| | | $R_{IDD} \leq 4.02 \text{ k}\Omega$ | 1.70 | | | |
| I_{BUS} | Total current drawn from the bus, in Mark State | $R_{IDD} = 30 \text{ k}\Omega$ | | 1.30 | 1.50 | mA |
| | | $R_{IDD} = 13 \text{ k}\Omega$ | | 2.70 | 3.00 | |
| | | $R_{IDD} = 8.45 \text{ k}\Omega$ | | 4.10 | 4.50 | |
| | | $R_{IDD} = 6.19 \text{ k}\Omega$ | | 5.50 | 6.00 | |
| | | $R_{IDD} = 4.87 \text{ k}\Omega$ | | 6.80 | 7.50 | |
| | | $R_{IDD} = 4.02 \text{ k}\Omega$ | | 8.20 | 9.00 | |
| ΔI_{BUS} | Bus current stability (over $\Delta V_{BUS} = 10 \text{ V}$, RX/RXI = mark) | | 0.2 | 2 | % | |
| I_{STC} | Idle current available for the application to draw from STC and V_{DD} (including current drawn from V_{DD}) | $R_{IDD} = 30 \text{ k}\Omega$ | 0.88 | 1.00 | 1.20 | mA |
| | | $R_{IDD} = 13 \text{ k}\Omega$ | 2.10 | 2.30 | 2.60 | |
| | | $R_{IDD} = 8.45 \text{ k}\Omega$ | 3.10 | 3.60 | 4.00 | |
| | | $R_{IDD} = 6.19 \text{ k}\Omega$ | 4.20 | 4.80 | 5.40 | |
| | | $R_{IDD} = 4.87 \text{ k}\Omega$ | 5.30 | 6.10 | 6.90 | |
| | | $R_{IDD} = 4.02 \text{ k}\Omega$ | 6.50 | 7.40 | 8.40 | |
| $\Delta I_{STC,SPACE}$ | Additional current available for the application when transmitting a space | – | 250 | – | μA | |
| $V_{B,\overline{PF}}$ | Threshold voltage on V_B to trigger \overline{PF} | $V_{STC} + 0.3$ | | $V_{STC} + 0.8$ | V | |
| $V_{\overline{PF},OH}$ | \overline{PF} voltage high ($I_{\overline{PF}} = -100 \mu\text{A}$) | $V_{IO} - 0.6$ | | V_{IO} | V | |
| $V_{\overline{PF},OL}$ | \overline{PF} voltage low (Note 6) ($I_{\overline{PF}} = 50 \mu\text{A}$) | 0 | | 0.6 | V | |

4. All voltages are referenced to GND
5. R_{IDD} resistor with 1% accuracy
6. \overline{PF} pin is pulled down with an on-chip resistor of typically 2 M Ω

Table 6. LOW POWER MODE – ELECTRICAL CHARACTERISTICS (Note 7)

| Symbol | Parameter | Min | Typ | Max | Unit | |
|--------------------|--|------------------------------------|------|------|------|----|
| $\Delta V_{BR,LP}$ | Voltage drop over bus rectifier ($V_{BUS} - V_B$) with $I_{BUS} = 3 \text{ mA}$ and external Schottky diodes (Note 8) | | | 0.35 | V | |
| $I_{STC,LP}$ | Max Current available for the application to draw from STC and V_{DD} (including current drawn from V_{DD}) (Note 10) | R_{IDD} (Note 9) = 30 k Ω | 2.0 | 2.3 | 2.7 | mA |
| | | (Note 9) = 13 k Ω | 4.1 | 4.8 | 5.5 | |
| $V_{STC,CLAMP,LP}$ | Clamp voltage on pin STC ($I_{DD} < I_{STC}$) (Note 11) | 9.4 | 10.5 | 11.5 | V | |

7. All voltages are referenced to GND
8. Forward voltage of 0.3 V max
9. Resistor with 1% accuracy
10. When configured in low power mode, the current limit of CS1 is set to 2 x the mark current level in M-BUS mode. The NCN5151 does not behave as a current source but as current limiter because V_{STC} never reaches the STC clamp level.
11. The STC clamp function protects the STC capacitor in case 2WLPM or 3WLPM is accidentally enabled during regular M-Bus operation.

Table 7. GENERAL – ELECTRICAL CHARACTERISTICS (Note 12)

| Symbol | Parameter | Min | Typ | Max | Unit |
|------------|--|------|-----|------|---------------|
| I_{CC} | Internal Supply Current (R_{IDD} (Note 13)) = 13k Ω , RX/RXI = mark) | – | 250 | 500 | μA |
| I_{IO} | Current drawn by the V_{IO} pin | –0.5 | – | 0.5 | μA |
| V_{RIDD} | Voltage on RIDD pin | 1.15 | 1.2 | 1.25 | V |

12. All voltages are referenced to GND
13. Resistor with 1% accuracy

NCN5151

Table 8. VDD REGULATOR ELECTRICAL CHARACTERISTICS (Note 14)

| Symbol | Parameter | Min | Typ | Max | Unit | |
|--------------------------|--|---|------|------|------|---|
| V _{DD} | Voltage on V _{DD} (I _{DD} < 15 mA) | 3.1 | 3.3 | 3.6 | V | |
| I _{DD} | Peak current that can be supplied by V _{DD} Note 15 with condition V _{STC} > 3.8 V | 15 | – | – | mA | |
| I _{DD, OFF} | V _{BUS} = 0 V, V _{STC} = 0 V | –0.5 | – | 0.5 | μA | |
| V _{POR, ON} | Power–on reset threshold to connect V _{DD} | 2.65 | 2.85 | 3.15 | V | |
| V _{POR, OFF} | Power–on reset threshold to disconnect V _{DD} | 2.55 | 2.75 | 3.00 | V | |
| V _{STC, VDDON} | Threshold voltage on pin STC to turn on V _{DD} regulator and pull high PF pin. | PMode high (V _B > 10.6 V) M–Bus Mode | 5.6 | 6.0 | 6.4 | V |
| | | PMode low (V _B < 10.6 V) Low Power Mode | 3.1 | 3.4 | 3.6 | V |
| V _{STC, VDDOFF} | Threshold voltage on pin STC to turn off V _{DD} regulator and pull low PF pin | 2.7 | 3.0 | 3.2 | V | |

14. All voltages are referenced to GND

15. Average current draw limited by I_{STC}

Table 9. M–BUS RECEIVER ELECTRICAL CHARACTERISTICS (Note 16)

| Symbol | Parameter | Min | Typ | Max | Unit |
|---|---|-----------------------|------|----------------------------------|------|
| V _T | Receiver threshold voltage | Mark – 8.2 | | Mark – 5.7 | V |
| V _{SC} | Mark level storage capacitor voltage | | | V _B | V |
| I _{SC, charge} | Mark level storage capacitor charge current | –40 | –25 | –15 | μA |
| I _{SC, discharge} | Mark level storage capacitor discharge current | 0.3 | 0.6 | –0.033 x I _{SC, charge} | μA |
| CDR | Charge/Discharge current ratio | 30 | 40 | – | |
| V _{TX, OH1} V _{TXI, OH1} | TX/TXI high–level voltage (I _{TX} /I _{TXI} = –100 μA) (Note 17) | V _{IO} – 0.6 | – | V _{IO} | V |
| V _{TXI, OL1} V _{TX, OL1} | TX/TXI low–level voltage (I _{TX} /I _{TXI} = 100 μA) | 0 | 0.20 | 0.35 | V |
| V _{TX, OL2} | TX/TXI low–level voltage (I _{TXI} = 1.1 mA) | – | 1 | 1.5 | V |
| I _{TX} , I _{TXI} | V _{TX} = 7.5 V, V _{STC} = 6 V | 0 | 11 | 16 | μA |

16. All voltages are referenced to GND

17. V_{STC} > V_{IO} + 1 V

Table 10. LOW POWER MODE RECEIVER ELECTRICAL CHARACTERISTICS (Note 18)

| Symbol | Parameter | Min | Typ | Max | Unit |
|---|--|------------------------|------------------------|-----------------|------|
| V _{TL, LP} | Receiver low threshold voltage (Falling V _{BUS}) | 1.2 | 1.6 | 2.4 | V |
| V _{TH, LP} | Receiver high threshold voltage (Rising V _{BUS}) | 1.5 | 2 | 2.7 | V |
| V _{TX, OH2} V _{TXI, OH2} | TX/TXI high–level output voltage (I _{TX} /I _{TXI} = –100 μA) with V _{STC} ≥ V _{IO} + 0.7 V | V _{IO} – 0.75 | V _{IO} – 0.6 | V _{IO} | V |
| V _{TX, OH3} V _{TXI, OH3} | TX/TXI high–level output voltage (I _{TX} /I _{TXI} = –50 μA) with V _{STC} ≥ V _{IO} + 0.5 V | V _{IO} – 0.6 | V _{IO} – 0.45 | V _{IO} | V |
| V _{TXI, OL3} V _{TX, OL3} | TX/TXI low–level output voltage (I _{TX} /I _{TXI} = 100 μA) | 0 | 0.20 | 0.35 | V |

18. All voltages are referenced to GND

Table 11. M-BUS TRANSMITTER ELECTRICAL CHARACTERISTICS (Note 19)

| Symbol | Parameter | Min | Typ | Max | Unit |
|-------------------------|--|----------------|-----|----------|---------|
| I_{MC} | Space level modulating current with $R_{RIS} = 100 \Omega$ (Note 20) | 12.5 | 15 | 18 | mA |
| V_{RIS} | Voltage on RIS pin | 1.2 | 1.4 | 1.6 | V |
| $V_{RX,IH}, V_{RXI,IH}$ | RX/RXI high-level input voltage | $V_{IO} - 0.8$ | | 5.5 | V |
| $V_{RX,IL}, V_{RXI,IL}$ | RX/RXI low-level input voltage | 0 | | 0.8 | V |
| I_{RX}, I_{RXI} | Current drawn from RX/RXI pins (Note 21) ($V_{IO} = 3 V$) | ± 6 | | ± 30 | μA |

19. All voltages are referenced to GND

20. Resistor with 1% accuracy

21. Including internal pull-up resistor on RX and internal pull-down resistor on RXI

Table 12. LOW POWER MODE TRANSMITTER ELECTRICAL CHARACTERISTICS (Note 22)

| Symbol | Parameter | Min | Typ | Max | Unit |
|------------------------------|--|------|------|------|---------|
| 2-WIRE LOW POWER MODE | | | | | |
| $I_{TX,2WLPM}$ | Transmission current with $R_{RIS} = 100 \Omega$ (Note 23) | 8.5 | 10 | 11.5 | mA |
| $V_{RIS,2WLPM}$ | Voltage on RIS pin | 0.85 | 1.00 | 1.15 | V |
| 3-WIRE LOW POWER MODE | | | | | |
| $V_{OD,OL}$ | OD low-level output voltage, $I_{OD} = 2 mA$ | 0 | 0.1 | 0.3 | V |
| $I_{LEAK,OD}$ | OD leakage current, $V_{OD} = 10 V$ | 0 | - | 1 | μA |

22. All voltages are referenced to GND

23. Resistor with 1% accuracy

Table 13. VB MONITOR ELECTRICAL CHARACTERISTICS (Note 24)

| Symbol | Parameter | Min | Typ | Max | Unit |
|----------------|--|----------------|-----|----------|------|
| $V_{VB,PMODE}$ | VB voltage level to enable PMODE pin | 8.0 | 9.4 | 10.5 | V |
| $V_{PMODE,OH}$ | PMODE high-level output voltage, $I_{PMODE} = -50 \mu A$ | $V_{DD} - 0.3$ | - | V_{DD} | V |
| $V_{PMODE,OL}$ | PMODE low-level output voltage, $I_{PMODE} = 50 \mu A$ | 0 | - | 0.3 | V |

24. All voltages are referenced to GND

Table 14. 2WLPM and 3WLPM INPUT CHARACTERISTICS (Note 25)

| Symbol | Parameter | Min | Typ | Max | Unit |
|----------------------------------|--|----------------|-----|----------------|---------|
| $I_{2WLPM,IL}$ $I_{3WLPM,IL}$ | 2WLPM / 3WLPM pull-down current, (voltage range: 0.2 to 3.3 V) | | 2 | | μA |
| $V_{2WLPM,IL}$ $V_{3WLPM,IL}$ | 2WLPM / 3WLPM low-level input voltage | 0 | - | 0.2 x V_{DD} | V |
| $V_{2WLPM,IH}$ $V_{3WLPM,IH}$ | 2WLPM / 3WLPM high-level input voltage | 0.8 x V_{DD} | - | V_{DD} | V |

25. All voltages are referenced to GND

Table 15. 2WLPM, 3WLPM, and OD TRUTH TABLE

| 2WLPM | 3WLPM | Operating Mode | OD |
|-------|-------|-----------------------|---|
| L | L | M-Bus | HiZ |
| L | H | 3 Wire Low Power Mode | Space (Note 26) state: Low Mark (Note 27) state: HiZ |
| H | L | 2 Wire Low Power Mode | High Impedance |
| H | H | Not Valid (Note 28) | Space state: Low Mark state: HiZ |

26. "Space" state means RX "0" or RXI "1"

27. "Mark" state means RX "1" or RXI "0"

28. Note 2WLPM and 3WLPM both High is not a valid combination. This state is not destructive for the NCN5151 device, but the communication will fail

NCN5151

APPLICATION SCHEMATICS – M-BUS APPLICATION ONLY

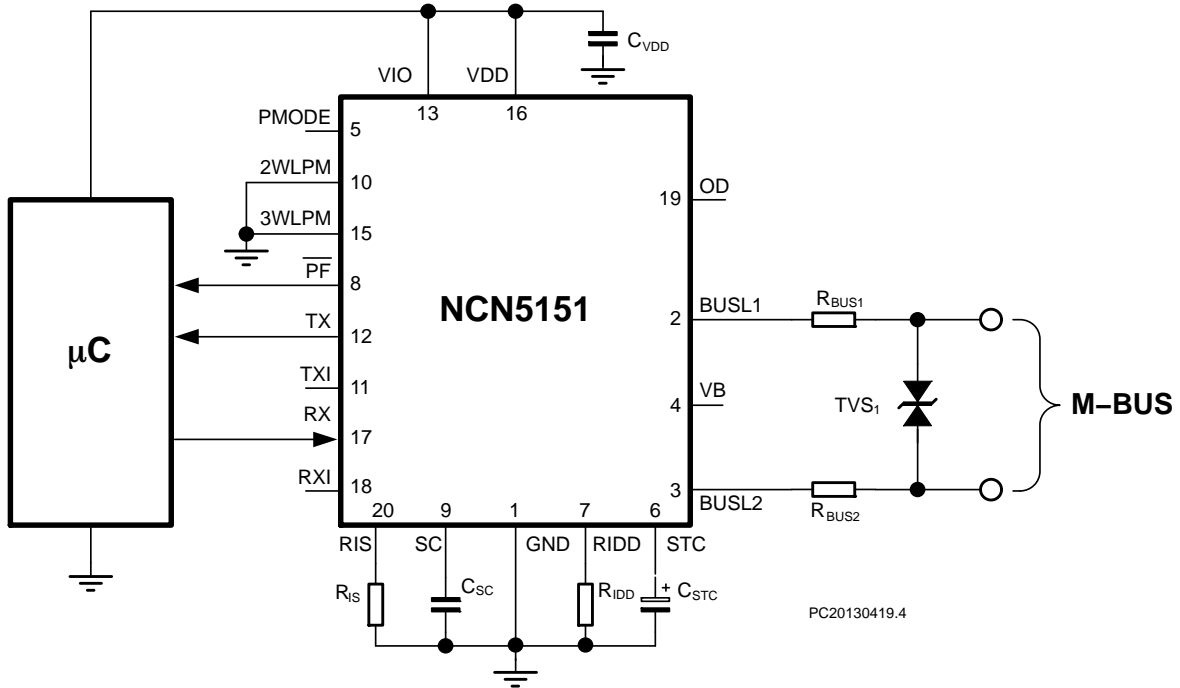

Figure 3. General Application Schematic

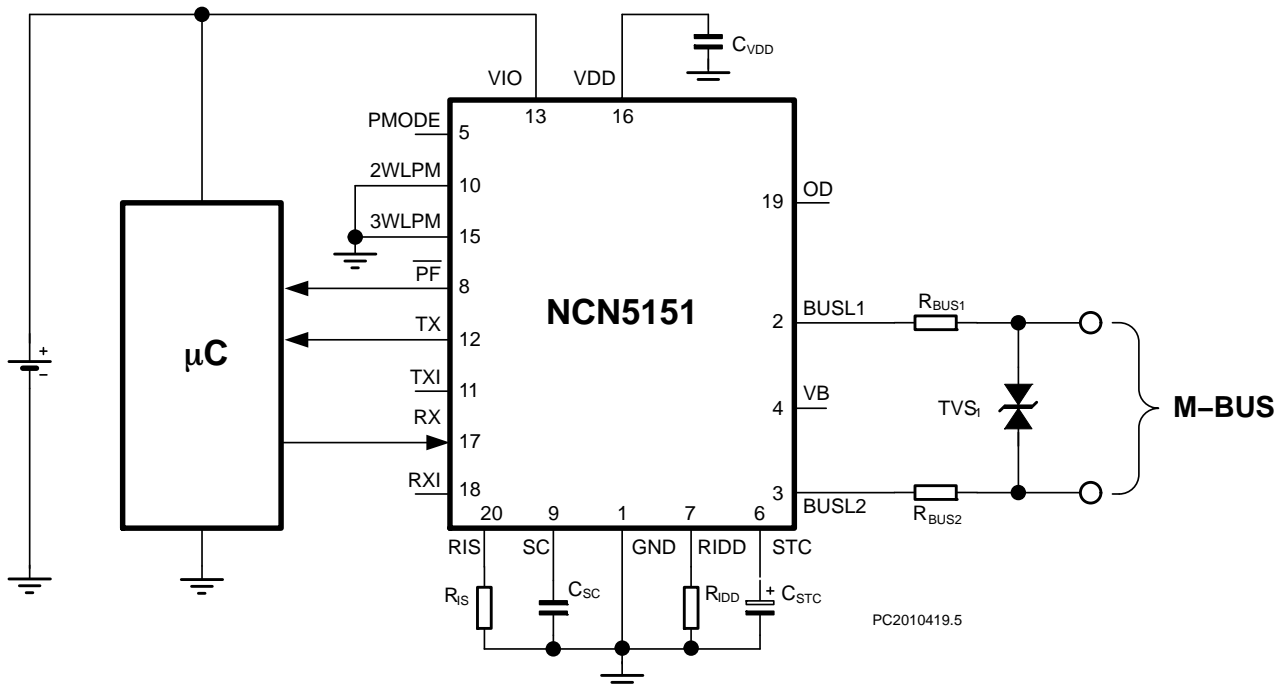

Figure 4. Application Schematic with External Power Supply

APPLICATION INFORMATION – M–BUS MODE

This section provides some information related to M–bus mode application.

The NCN5151 is a slave transceiver for use in the M–Bus protocol. The bus connection is fully polarity independent. The transceiver will translate the bus voltage modulation from master–to–slave communication to TTL UART communication, and in the other direction translate UART voltage levels to bus current modulation. The transceiver also integrates a voltage regulator for utilizing the current drawn in this way from the bus, and an early power fail warning. The transceiver also supports an external power supply and the I/O high level can be set to match the slave sensor circuit. A complete block diagram is shown in Figure 2. Each section will be explained in more detail below.

M–Bus Protocol

M–BUS is a European standard for communication and powering of utility meters and other sensors. Communication from master to slave is achieved by voltage–level signaling. The master will apply a nominal +36 V to the bus in idle state, or when transmitting a logical 1 (“mark”). When transmitting a logical 0 (“space”), the master will drop the bus voltage to a nominal +24 V. Communication from the slave to the master is achieved by current modulation. In idle mode or when transmitting a logical 1 (“mark”), the slave will draw a fixed current from the bus. When transmitting a logical 0 (“space”), the slave will draw an extra nominal 15 mA from the bus. M–BUS uses a half–duplex 11–bit UART frame format, with 1 start bit, 8 data bits, 1 even parity bit and a stop bit. Communication speeds allowed by the M–BUS standard are 300, 600, 2400, 4800, 9600, 19200 and 38400 baud, all of which are supported by the NCN5151.

Bus Connection and Rectification

The bus should be connected to the pins BUSL1 and BUSL2 through series resistors to limit the current drawn from the bus in case of failure (according to the M–BUS standard). Typically, two 220 Ω resistors are used for this purpose.

Since the M–BUS connection is polarity independent, the NCN5151 will first rectify the bus voltage through a semi–active bridge rectifier.

Slave Power Supply (Bus Powered)

A slave device can be powered by the M–BUS or from an external supply. The M–BUS standard requires the slave to draw a fixed current from the bus. This is accomplished by the constant current source CS1. This current is used to charge the external storage capacitor C_{STC} . The current drawn from the bus is defined by the programming resistor R_{IDD} . The bus current can be chosen in increments of

1.5 mA called unit loads. Table 5 lists the different values of programming resistors needed for different unit loads, as well as the current drawn from the bus (I_{BUS}) and the current that can be drawn from the STC pin (I_{STC}). I_{STC} is slightly less than I_{BUS} to account for the internal power consumption of the NCN5151.

The resistors R_{IDD} used must be at least 1% accurate. Note that using 5 and 6 Unit Loads is not covered by the M–BUS standard.

When the voltage on the STC pin reaches $V_{STC,VDDON}$ the LDO is turned on, and will regulate the voltage on the VDD pin to 3.3 V, drawing current from the storage capacitor. A decoupling capacitor of minimum 1 μ F is required on the VDD pin for stability of the regulator. On the STC pin, a minimum capacitance of 10 μ F is required. Furthermore, the ratio C_{STC}/C_{VDD} must be larger than 9. The voltage on the STC pin is clamped to V_{STC} by a shunt regulator which will dissipate any excess current that is not used by the NCN5151 or external circuits.

Slave Power Supply (External Battery)

In case the external sensor circuit consumes more than the allowed bus current or the sensor should be kept operational when the bus is not present, an external power supply, such as a battery, is required (Figure 4).

When the external circuitry uses different logical voltage levels, simply connect the power supply of that voltage level to VIO, so that the RX, RXI, TX, TXI and \overline{PF} pins will respond to the correct voltage levels. The NCN5151 will still be powered from the bus, but all communication will be translated to the voltage level of VIO.

Contrary to the NCN5150, the NCN5151 does not support the remote supply/Battery support because of the $V_{STC,VDDOFF}$ level which has been lowered below 3.3 V for low bus voltage operation.

Communication, Master to Slave

M–BUS communication from master to slave is based on voltage level signaling. To differentiate between master signaling and voltage drop caused by the signaling of another slave over cabling resistance, etc., the mark level

V_{MARK} is stored, and only when the bus voltage drops to less than V_T will the NCN5151 detect communication. A simplified schematic of the receiver is shown in Figure 7. The received data is transmitted on the pins TX and TXI, as shown in the waveforms in Figure 6.

An external capacitor must be connected to the SC pin to store the mark voltage level. This capacitor is charged to V_S .

Discharging of this capacitor is typically 40x slower, so that the voltage on SC drops only a little during the time the master is transmitting a space. The value of C_{SC} must be chosen in the range of 100 nF – 330 nF.

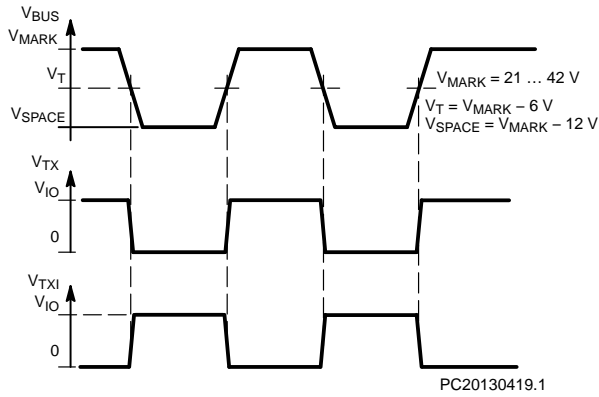

Figure 6. Master to Slave Communication

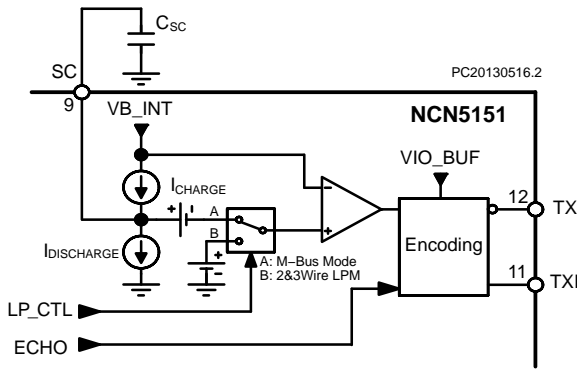

Figure 7. Receiver Block

Communication, Slave to Master

M-BUS communication from slave to master uses bus current level modulation while the voltage remains constant. This current modulation can be controlled from either the RX or RXI pin as shown in Figures 8 and 9. When transmitting a space (“0”), the current modulator will draw an additional current from the bus. This current can be set with a programming resistor R_{RIS} . To achieve the space current required the M-BUS standard, R_{RIS} should be 100 Ω . A simplified schematic of the transmitter is shown in Figure 10.

Because the M-BUS protocol is specified as half-duplex, an echo function will cause the transmitted signal on RX or RXI to appear on the receiver outputs TX and TXI. Should the master attempt to send at the same time, the bitwise added signal of both sources will appear on these pins, resulting in invalid data.

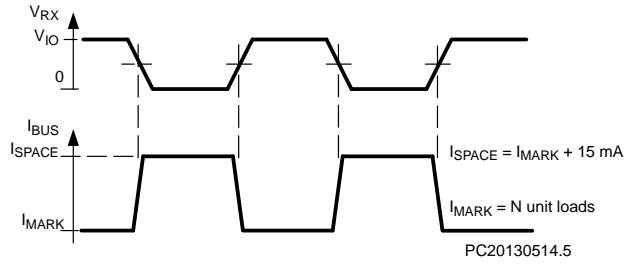

Figure 8. Slave to Master Communication Driving RX

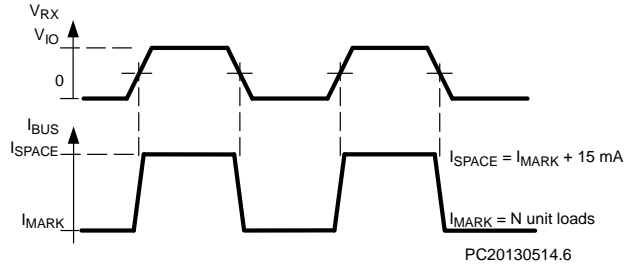

Figure 9. Slave to Master Communication Driving RXI

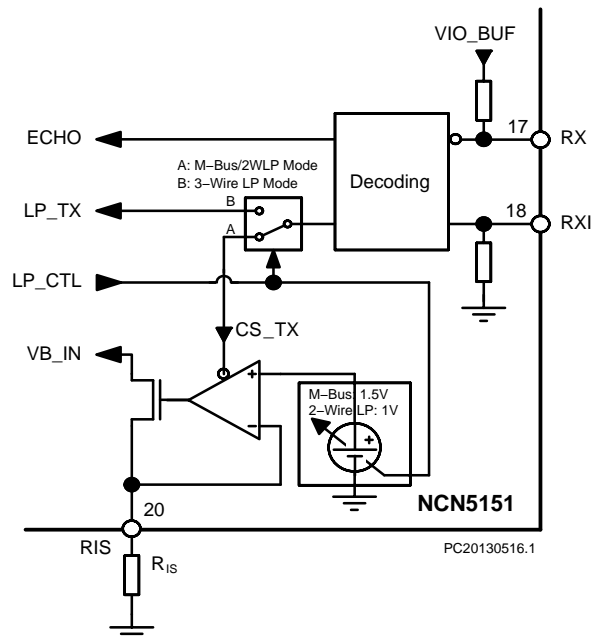

Figure 10. Transmitter Block

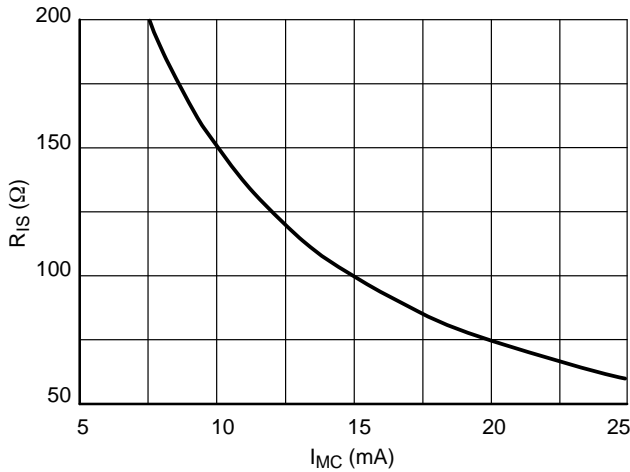

Figure 11. Typical Modulation Current and RIS Resistor

Power On/Off Sequence and Power Fail Indicator

The power-on and power-off sequence of the NCN5150 is shown in Figure 12. Shown also in Figure 12 is the operation of the \overline{PF} pin. This pin is used to give an early warning to the microcontroller that the bus power is collapsing, allowing the microcontroller to save its data and shut down gracefully. The times t_{on} and t_{off} can be approximated by the following formulas:

$$t_{on} = \frac{C_{STC}}{I_{STC}} V_{STC,VDDON}$$

$$t_{off} = \frac{C_{STC}}{I_{DD} + I_{STC}} (V_{STC,CLAMP} - V_{STC,VDDOFF})$$

Where I_{CC} is the internal current consumption of the NCN5151 and I_{DD} is the current consumed by external circuits drawn from either VDD or STC. These formulas can

be used to dimension the value of the bulk C_{STC} needed, taking into account that the M-BUS standard requires t_{on} to be less than 3 s.

For certain applications where the power drawn from the bus is not used in external circuits, the storage capacitor value can be much lower. The NCN5151 requires a minimum STC capacitance of 10 μF (and $C_{STC}/C_{VDD} > 9$) to ensure that the bus current regulation is stable under all conditions.

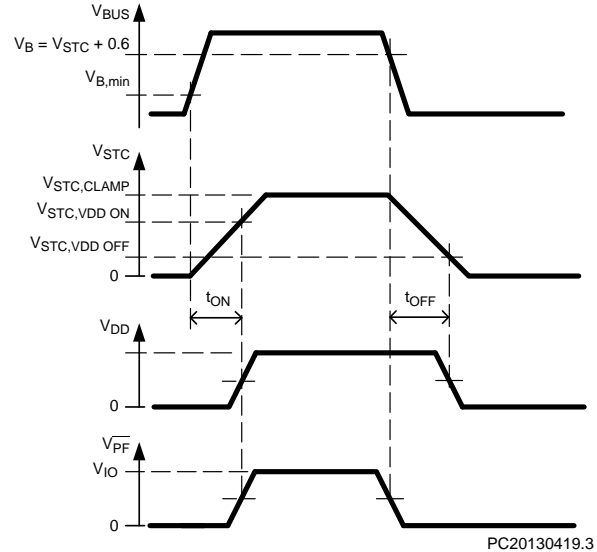

Figure 12. Power-on and Power-off

Thermal Shutdown

The NCN5151 includes a thermal shutdown function disabling the transmitter in case of excessive junction temperature.

Table 17. TYPICAL BILL OF MATERIALS – LOW POWER MODE

| Reference Designator | Value (Typical) | Tolerance | Manufacturer | Part Number | Note |
|--|------------------|------------|------------------|----------------|---|
| U ₁ | | | ON Semiconductor | NCN5151 | |
| TVS ₁ | 40 V | | ON Semiconductor | 1SMA40AT3G | |
| TVS ₂ | 30 V | | ON Semiconductor | 1SMA30AT3G | |
| D1, D2 | | | ON Semiconductor | BAS70LT1G | Absolute maximum reverse voltage >40 V |
| C _{VDD} | ≥1 μF | -20%, +80% | | | |
| R _{IS} | 100 Ω | 1% | | | |
| C _{SC} | 220 nF | -20%, +80% | | | |
| R _{BUS1LP} R _{BUS2LP} | 33 Ω | | Murata | PRG18B330MB1RB | Over-current protection resistor type are recommended for Low Power Modes |
| R _{OD} | 560 Ω | 10% | | | |
| R _{IDD} | 1 U _L | 30 kΩ | 1% | | |
| | 2 U _L | 13 kΩ | 1% | | |
| C _{STC} | 1 U _L | <330 μF | 10% | | Min : 22 μF with C _{STC} / C _{VDD} > 9 |
| | 2 U _L | <680 μF | 10% | | |

APPLICATION INFORMATION – LOW POWER MODE

3-Wire LP Mode – RF Module – Bidirectional

This section provides some information related to the NCN5151 operating in Low Power mode. As depicted in Figure 13, the NCN5151 also offers the possibility to build an extremely low power communication with an external RF Module.

This topology uses a 3-wire interface: the regular bus lines (BUSL1, BUSL2) and the open drain pin (OD).

This three-wire interface is designed in such a way that when the system is switched on, the Sensor System detects via the third contact V_{OD} whether any direct connection with the external battery module exists. If this is the case, the Sensor System enables the 3WLPM (three-wire low power mode) pin. The low power logic changes the operating mode of the transmitter block (Figures 2 and 10). The communication from slave to RF module does not take place via energy-intensive current modulation, but instead by means of a purely digital signal on the OD pin. This enables extremely energy-saving communication with the master.

As with the M-Bus, the RF module signals the data to the NCN5151 through voltage modulation but in this case this is purely ON/OFF keying. This means the power supply (maximum of 9 V) is simply switched on and off. As illustrated in Figure 7 the receiver threshold switches to a level referenced to ground instead of the mark state. The sensor system has to make sure that it has sufficient energy to send data and save enough energy in a capacitor for this purpose. During communication from the RF module to the sensor, the sensor system must also have sufficient energy and buffer this if necessary. The power supply can be

between 4.75 and 9 V; two 3 V lithium batteries are normally used in a system like this.

Figure 17 illustrates this bidirectional communication in 3-wire LP mode.

The OD pin has to be protected against surge transients with a TVS and a series resistor R_{OD}. This resistor acts also as a current limiter in case of a short between the 9V battery module and the wire “Data_In” going to the OD connector, while 3WLPM and RX/RXI are active. The current through the OD pin is limited to 20 mA. Therefore a typical R_{OD} resistor of 560 Ω is recommended. (Note that the internal OD switch has a typical R_{DS(on)} of 50 Ω)

2-Wire LP Mode – SCR – Bidirectional

The second low power mode works with a 2-wire interface also called SCR (System for meter Communication and Readout for powerless meters) which is enabled with the 2WLPM input pin (see Figure 14).

The communication from master to slave is done with ON/OFF keying similar to 3-wire LP mode, but the communication from slave to master uses current modulation similar to the current modulation used in the M-Bus protocol. In order to handle the low supply voltage (down to 4.75 V) and limit voltage losses, the current modulation amplitude is reduced with 33% (10 mA vs 15 mA) as illustrated in Figure 10.

Figure 18 illustrates the bidirectional communication in 2-wire LP mode.

Precautions regarding the stored energy during ON/OFF keying are also valid for this mode

MBUS and Low Power Mode Recognition

The NCN5151 includes a VB voltage monitor with an output pin PMODE (Power Mode) indicating whether VB voltage is above 9.5 V typical. This information is sent to the sensor system which determines the relevant mode (using the OD state pin): M-Bus, 2-wire or 3-wire low power mode. The sensor system then signals the NCN5151 the chosen operating mode using 2WLPM and 3WLPM pins (see Figures 15 and 16). During 2WLPM or 3WLPM the \overline{PF} output is disabled and pulled to ground.

By keeping the selection mode mechanism outside the NCN5151, the user can enhance the meter application robustness and its reliability through the sensor system firmware based on their application environment.

Table 15 gives an overview of the low power pin truth table. Note that both 2WLPM and 3WLPM pins enabled is not allowed. This combination is safe for the NCN5151 but the communication with the master may fail.

CS1 Current Source and STC Clamp

Contrary to M-BUS mode, in low power mode the NCN5151 does not behave as a constant current load. The STC clamp level ($V_{STC,CLAMP,LP}$) is increased higher than the low power mode supply (9.5 V typical) in order to never trigger it under normal operating range. Thus the CS1 will only act as current limiter during startup and ON/OFF keying and in steady state the CS1 block will be pinched off between STC and VB.

This current limit in low power mode is double compared to the M-BUS mode (Table 6, Figures 15 and 16). This allows a faster recharge of C_{STC} during ON/OFF keying and a duty cycle close to 50%.

Low Power Mode and Minimum Operating Voltage

The user should take several precautions when using the low power modes in order to maximize the voltage seen by the NCN5151 circuitry.

It is required to replace the 220 Ω bus resistors with current limiting resistor (33 Ω typ, PTC type with rapid operation). This will significantly reduce the voltage drop, especially during current modulation (slave to master) in 2WLPM and guarantee sufficient short protection.

An external Schottky (with forward voltage of 0.3 V max) is also required between BUSL1/BUSL2 and the VB pin in order to reduce the overall voltage drop on the internal diode bridge.

These adaptations allow the NCN5151 to operate in low power mode with a minimum battery voltage of 4.75 V.

As mentioned in both low power mode sections, it is important to maintain a minimum voltage level on the STC pin during the ON/OFF keying. Below 3.8 V on STC, the low dropout regulator may not be able to regulate the VDD supply pin correctly.

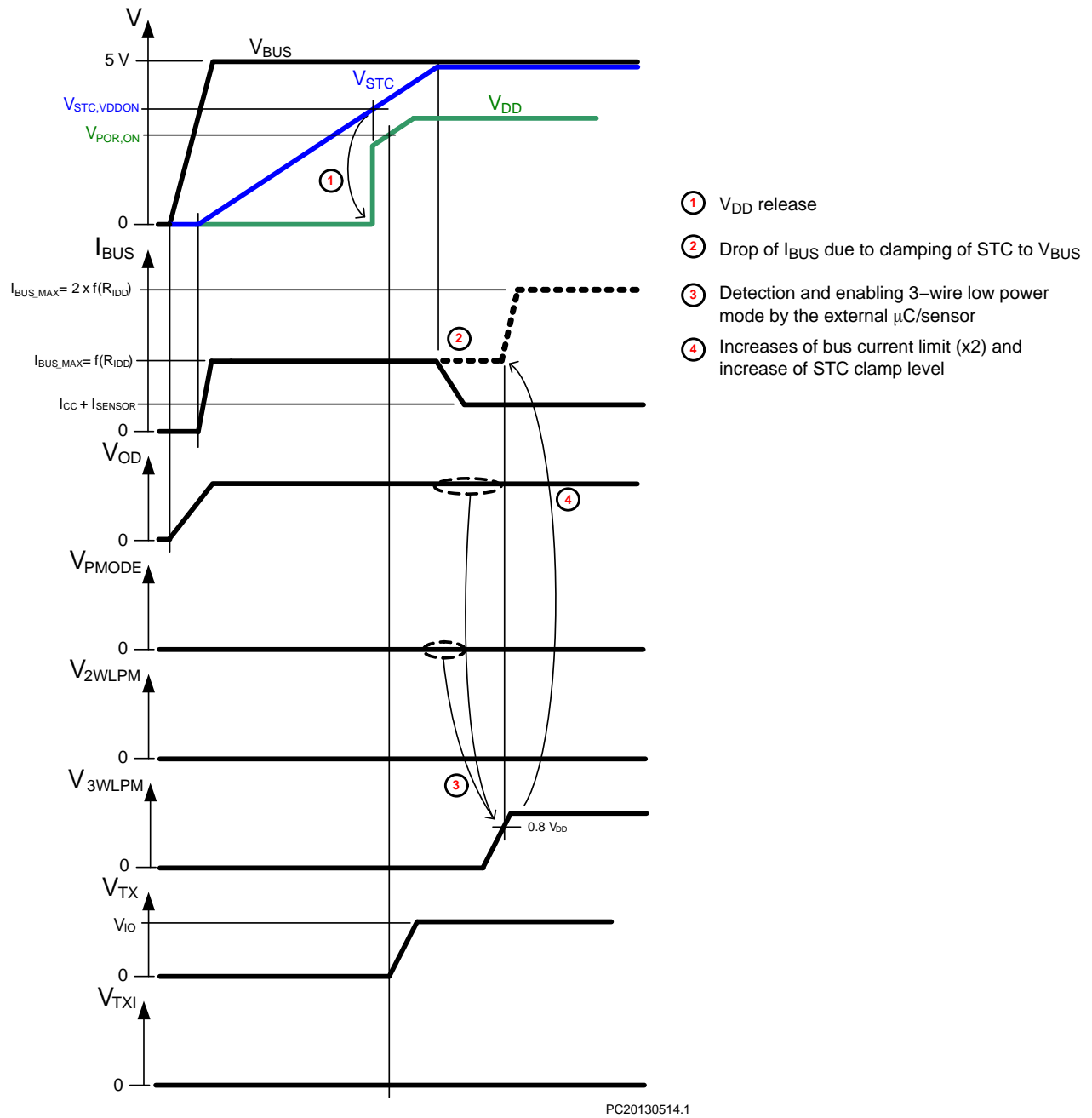

Figure 15. Startup Sequence in 3-Wire Low Power Mode

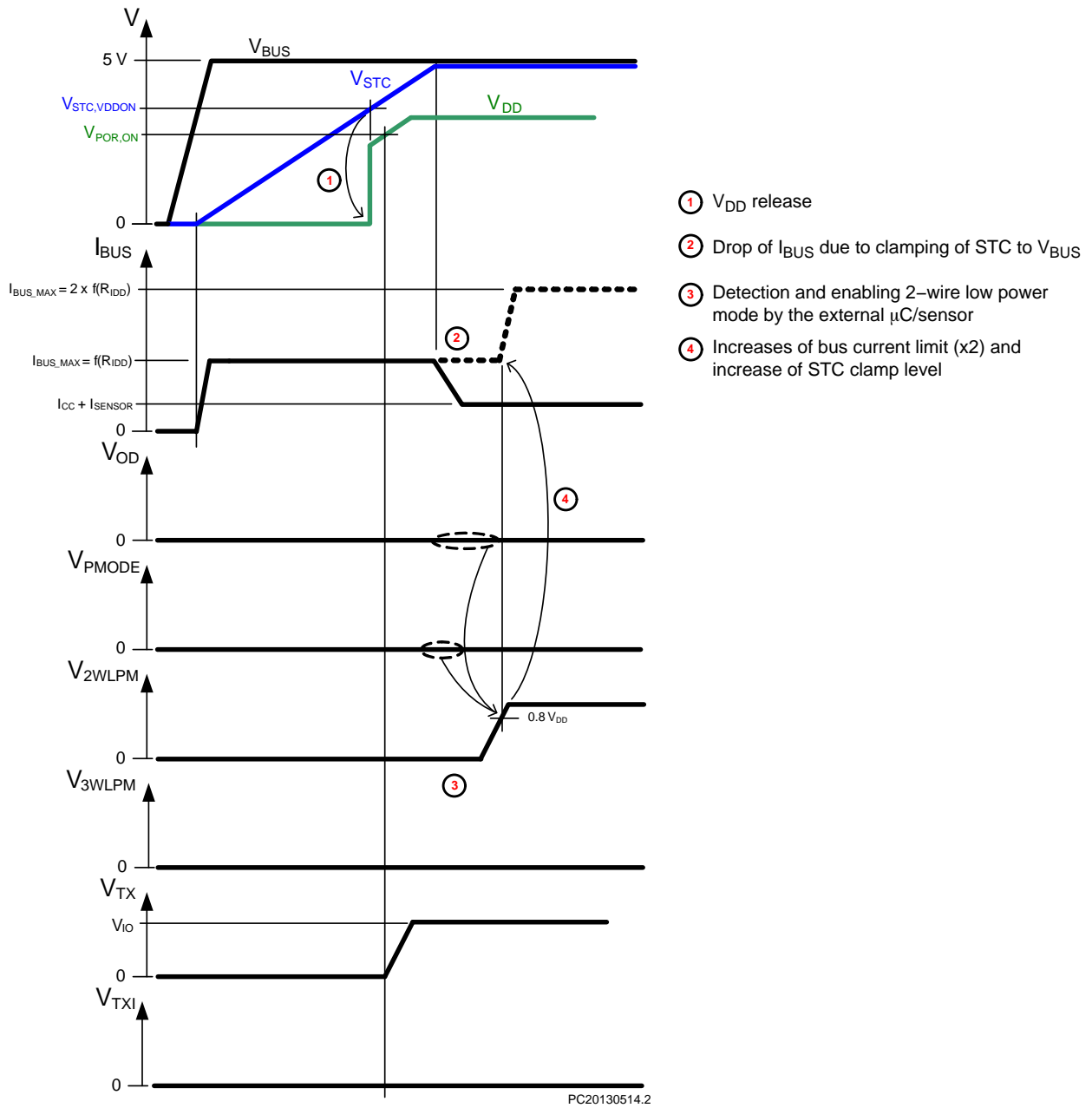
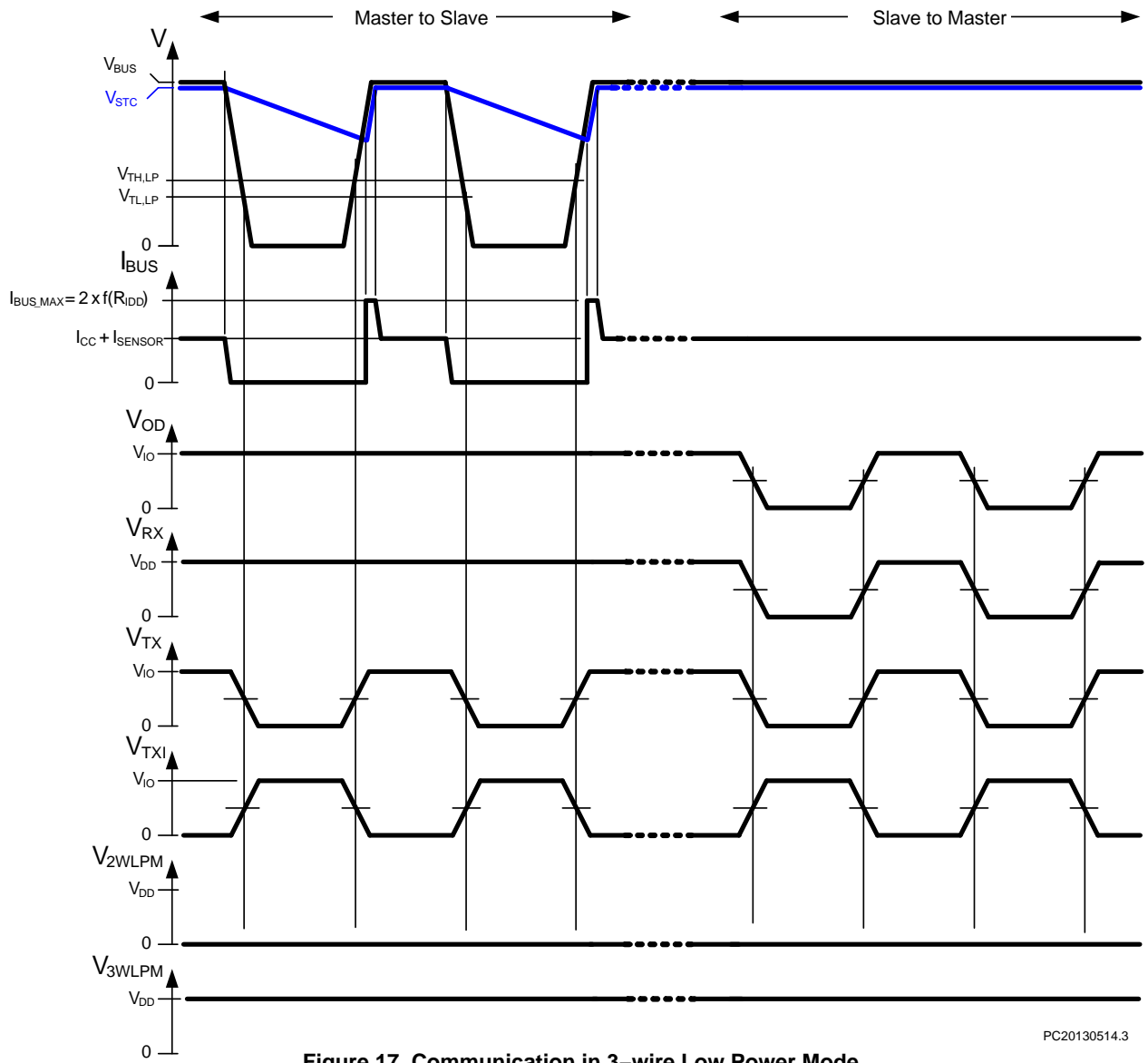

Figure 16. Startup Sequence in 2-Wire Low Power Mode

NCN5151



PC20130514.3

Figure 17. Communication in 3-wire Low Power Mode

NCN5151

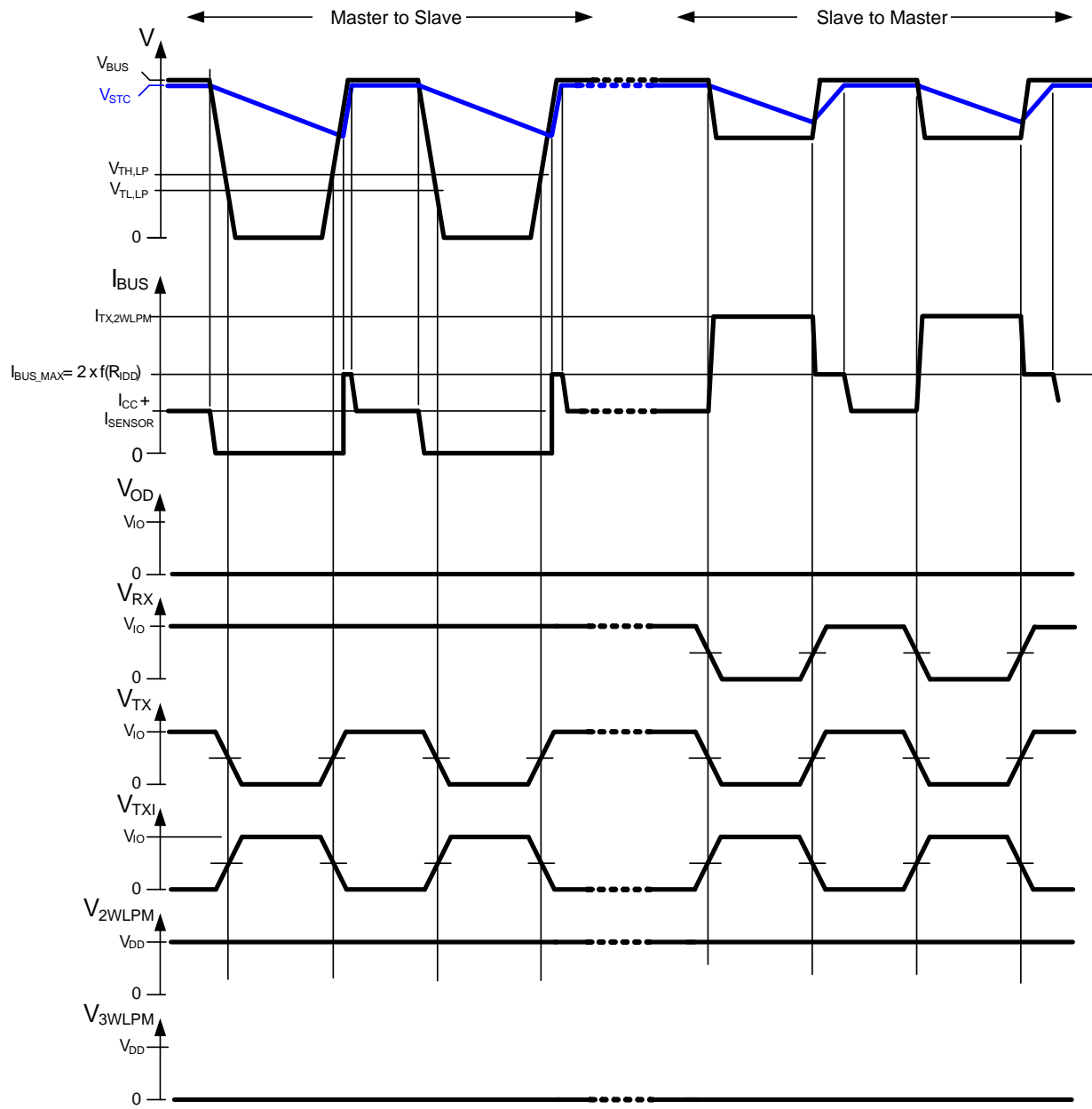

PC201305144

Figure 18. Communication in 2-wire Low Power Mode

Table 18. ORDERING INFORMATION

| Device | Package | Shipping† |
|--------------|--------------------------|--------------------|
| NCN5151MNTWG | NQFP20, 4x4 (Pb-free) | 2500 / Tape & Reel |

†For information on tape and reel specifications, including part orientation and tape sizes, please refer to our Tape and Reel Packaging Specifications Brochure, BRD8011/D.

MECHANICAL CASE OUTLINE PACKAGE DIMENSIONS

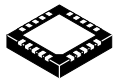

SCALE 2:1

QFN20, 4x4, 0.5P
CASE 485E
ISSUE C

DATE 13 FEB 2018

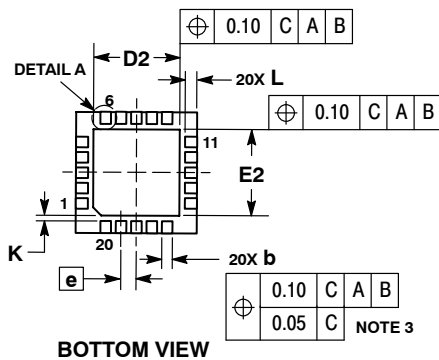
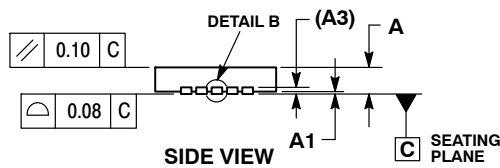
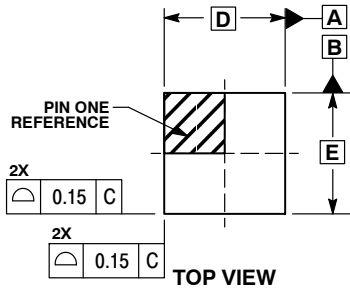

SOLDERING FOOTPRINT*

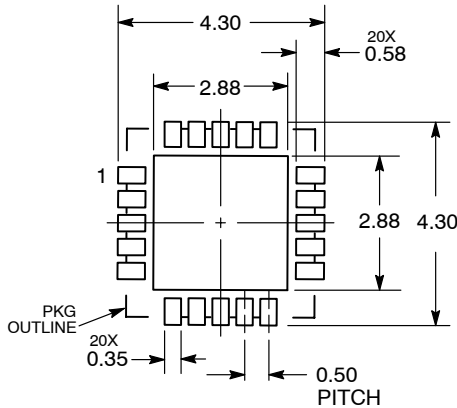

DIMENSIONS: MILLIMETERS

*For additional information on our Pb-Free strategy and soldering details, please download the ON Semiconductor Soldering and Mounting Techniques Reference Manual, SOLDERRM/D.

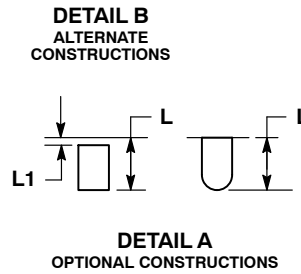
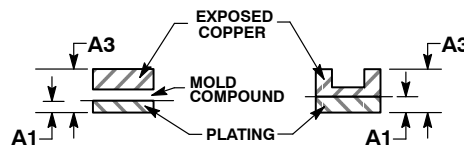

NOTES:

1. DIMENSIONING AND TOLERANCING PER ASME Y14.5M, 1994.
2. CONTROLLING DIMENSION: MILLIMETERS.
3. DIMENSION b APPLIES TO PLATED TERMINAL AND IS MEASURED BETWEEN 0.15 AND 0.30 MM FROM THE TERMINAL TIP.
4. COPLANARITY APPLIES TO THE EXPOSED PAD AS WELL AS THE TERMINALS.

| MILLIMETERS | | |
|-------------|------|------|
| DIM | MIN | MAX |
| A | 0.80 | 1.00 |
| A1 | --- | 0.05 |
| A3 | 0.20 | REF |
| b | 0.20 | 0.30 |
| D | 4.00 | BSC |
| D2 | 2.60 | 2.90 |
| E | 4.00 | BSC |
| E2 | 2.60 | 2.90 |
| e | 0.50 | BSC |
| K | 0.20 | REF |
| L | 0.35 | 0.45 |
| L1 | 0.00 | 0.15 |

GENERIC MARKING DIAGRAM*

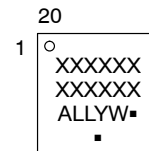

- XXXXXX= Specific Device Code
- A = Assembly Location
- LL = Wafer Lot
- Y = Year
- W = Work Week
- = Pb-Free Package

(Note: Microdot may be in either location)

*This information is generic. Please refer to device data sheet for actual part marking. Pb-Free indicator, "G" or microdot "▪", may or may not be present. Some products may not follow the Generic Marking.

| | | |
|------------------|------------------|--|
| DOCUMENT NUMBER: | 98AON03163D | Electronic versions are uncontrolled except when accessed directly from the Document Repository. Printed versions are uncontrolled except when stamped "CONTROLLED COPY" in red. |
| DESCRIPTION: | QFN20, 4X4, 0.5P | PAGE 1 OF 1 |

onsemi and onsemi are trademarks of Semiconductor Components Industries, LLC dba onsemi or its subsidiaries in the United States and/or other countries. onsemi reserves the right to make changes without further notice to any products herein. onsemi makes no warranty, representation or guarantee regarding the suitability of its products for any particular purpose, nor does onsemi assume any liability arising out of the application or use of any product or circuit, and specifically disclaims any and all liability, including without limitation special, consequential or incidental damages. onsemi does not convey any license under its patent rights nor the rights of others.

onsemi, **Onsemi**, and other names, marks, and brands are registered and/or common law trademarks of Semiconductor Components Industries, LLC dba "**onsemi**" or its affiliates and/or subsidiaries in the United States and/or other countries. **onsemi** owns the rights to a number of patents, trademarks, copyrights, trade secrets, and other intellectual property. A listing of **onsemi**'s product/patent coverage may be accessed at www.onsemi.com/site/pdf/Patent-Marking.pdf. **onsemi** reserves the right to make changes at any time to any products or information herein, without notice. The information herein is provided "as-is" and **onsemi** makes no warranty, representation or guarantee regarding the accuracy of the information, product features, availability, functionality, or suitability of its products for any particular purpose, nor does **onsemi** assume any liability arising out of the application or use of any product or circuit, and specifically disclaims any and all liability, including without limitation special, consequential or incidental damages. Buyer is responsible for its products and applications using **onsemi** products, including compliance with all laws, regulations and safety requirements or standards, regardless of any support or applications information provided by **onsemi**. "Typical" parameters which may be provided in **onsemi** data sheets and/or specifications can and do vary in different applications and actual performance may vary over time. All operating parameters, including "Typicals" must be validated for each customer application by customer's technical experts. **onsemi** does not convey any license under any of its intellectual property rights nor the rights of others. **onsemi** products are not designed, intended, or authorized for use as a critical component in life support systems or any FDA Class 3 medical devices or medical devices with a same or similar classification in a foreign jurisdiction or any devices intended for implantation in the human body. Should Buyer purchase or use **onsemi** products for any such unintended or unauthorized application, Buyer shall indemnify and hold **onsemi** and its officers, employees, subsidiaries, affiliates, and distributors harmless against all claims, costs, damages, and expenses, and reasonable attorney fees arising out of, directly or indirectly, any claim of personal injury or death associated with such unintended or unauthorized use, even if such claim alleges that **onsemi** was negligent regarding the design or manufacture of the part. **onsemi** is an Equal Opportunity/Affirmative Action Employer. This literature is subject to all applicable copyright laws and is not for resale in any manner.

ADDITIONAL INFORMATION

TECHNICAL PUBLICATIONS:

Technical Library: www.onsemi.com/design/resources/technical-documentation
onsemi Website: www.onsemi.com

ONLINE SUPPORT: www.onsemi.com/support

For additional information, please contact your local Sales Representative at www.onsemi.com/support/sales