

High Side Gate Driver

130 V, 2.0 A / 3.0 A

Product Preview

NCP51313

NCP51313 is a 130 V high side driver with 2.0 A source and 3.0 A sink drive capability for DC-DC power supplies and inverters. NCP51313 offers best in class propagation delay, low quiescent current and low switching current at high frequencies of operation. This device is tailored for highly efficient power supplies operating at high frequencies. NCP51313 is offered in two versions, NCP51313A/B. NCP51313A has a typical 50 ns propagation delay, while NCP51313B has a typical propagation delay of 20 ns. NCP51313 comes in standard SO8 package.

Features

- High Voltage Range: Up to 130 V
- NCP51313A: Typical 50 ns Propagation Delay
- NCP51313B: Typical 20 ns Propagation Delay
- Very Low Quiescent and Operating Currents
- Typ 11 ns Rise / 10 ns Fall Time under 1 nF Load
- 2.0 A Source / 3.0 A Sink Currents
- Under-Voltage Lockout for V_{CC} and V_B
- 3.3 V and 5 V Input Logic Compatible
- High dv/dt Immunity up to 50 V/ns
- High Negative Transient Immunity on Bridge Pin
- These are Pb-Free Devices

Applications

- DC-DC Converters
- Class-D Audio Amplifiers
- Motor Controls

This document contains information on a product under development. onsemi reserves the right to change or discontinue this product without notice.



SOIC-8 NB
CASE 751-07

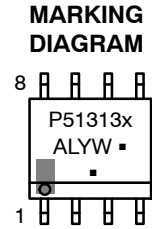

P51313 = Specific Device Code
 x = A or B
 A = Assembly Location
 L = Wafer Lot
 Y = Year
 W = Work Week
 ■ = Pb-Free Package

(NOTE: Microdot may be in either location)

PINOUT INFORMATION

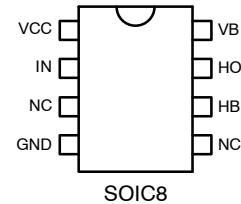

ORDERING INFORMATION

Device	Input Filter	Package	Shipping†
NCP51313ADR2G	Yes	SOIC8 (Pb-Free)	2500 / Tape & Reel
NCP51313BDR2G (on demand)	No	SOIC8 (Pb-Free)	2500 / Tape & Reel

†For information on tape and reel specifications, including part orientation and tape sizes, please refer to our Tape and Reel Packaging Specifications Brochure, BRD8011/D.

NCP51313

Table 1. PIN DESCRIPTION SO8 PACKAGE

Pin Out SO8	Name	Function
1	VCC	Logic supply
2	IN	Input
3	NC	Not connected
4	GND	Ground reference
5	NC	Not connected
6	HB	High side supply return
7	HO	High side output
8	VB	High side voltage supply

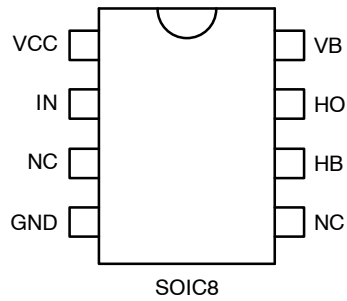

Figure 1. Pinout

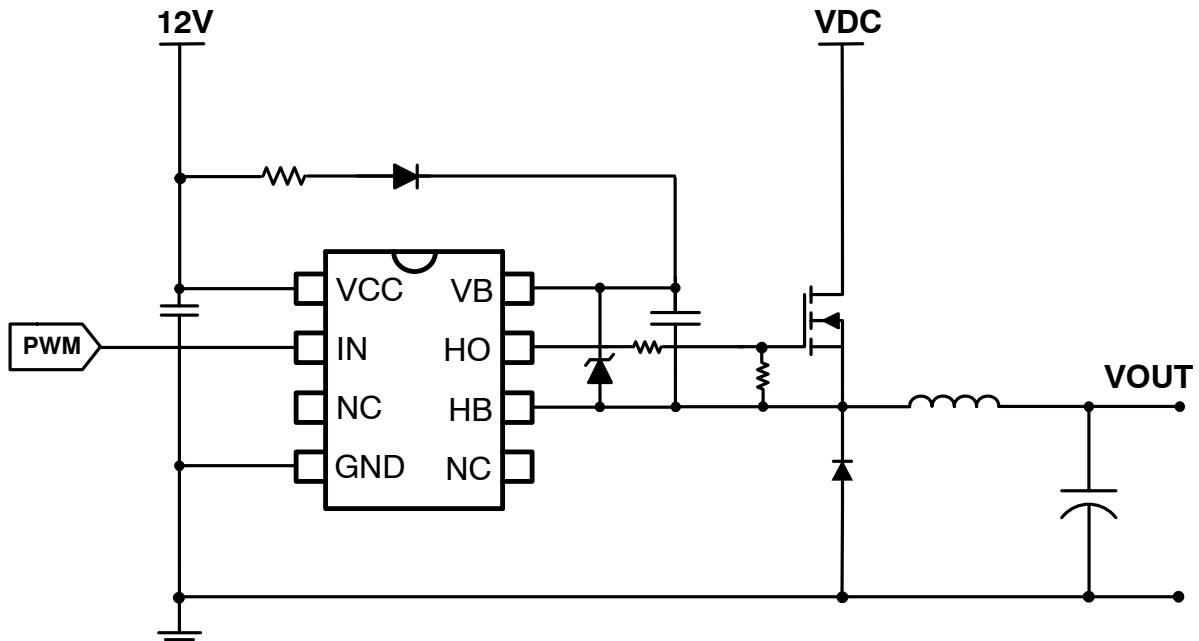

Figure 2. Typical Application Schematic

NCP51313

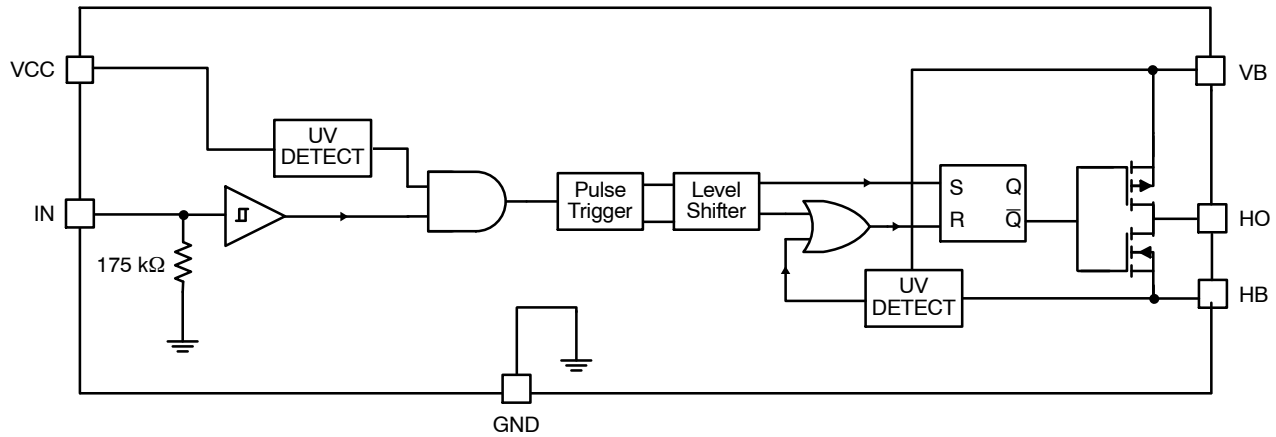

Figure 3. Internal Block Diagram for NCP51313

Table 2. ABSOLUTE MAXIMUM RATINGS (All voltages are referenced to GND pin)

Symbol	Rating	Value	Unit
V _{CC}	Input Voltage Range	-0.3 to 20	V
V _B	High Side Boot Pin Voltage	-0.3 to 150	V
V _B -V _{HB}	High Side Floating Voltage	-0.3 to 20	V
V _{HB}	High Side Bridge Pin Voltage	V _B - 20 to V _B + 0.3	V
V _{HO}	High Side Drive Output Voltage	V _{HB} - 0.3 to V _B + 0.3	V
dV _{HB} /dt	Allowable HB Slew Rate	50	V/ns
V _{IN}	Drive Input Voltage	-5 to V _{CC} + 0.3	V
T _{J(MAX)}	Junction Temperature	150	°C
T _{STG}	Storage Temperature Range	-55 to 150	°C
	ESD Capability (Note 1)		
	HBM Model	2000	V
	CDM Model	1000	V
	Lead Temperature Soldering Reflow, Pb-Free Versions (Note 2)	260	°C

Stresses exceeding those listed in the Maximum Ratings table may damage the device. If any of these limits are exceeded, device functionality should not be assumed, damage may occur and reliability may be affected.

1. This device series incorporates ESD protection and is tested by the following methods.

ESD Human Body Model tested per JS-001/MIL-STD-883 method 3015

ESD Charged Device Model tested per JS-002/JEP157

Latchup Current Maximum Rating: ≤100 mA per JEDEC standard: JESD78E

2. For information, please refer to our Soldering and Mounting Techniques Reference Manual, SOLDERRM/D

Table 3. THERMAL CHARACTERISTICS

Symbol	Rating	Value	Unit
R _{θJA}	Thermal Resistance, Junction to Air SO8	130	°C/W
Ψ _{J-T}	Junction to Top Characterization Parameter SO8	4.8	°C/W
Ψ _{J-B}	Junction to Bottom (Leads) Characterization Parameter SO8 (Note 3)	63	°C/W

3. Device mounted on single side PCB with two buried planes, no vias to buried planes, 1.6 mm, FR4, board size 80 x 80 mm, trace and plane thickness 35 μm, power dissipation 54 mW, cooling done only by traces (8 lines 25 x 0.6 mm), no additional polygon. Ambient temperature 25°C.

NCP51313

Table 4. RECOMMENDED OPERATING CONDITIONS

Symbol	Parameter	Min	Max	Unit
V _{CC}	Input Voltage Range	8	19	V
V _B -V _{HB}	High Side Floating Voltage	8	19	V
V _{HB}	High Side Bridge Pin Voltage	-2	110	V
V _{HO}	High Side Output Voltage	V _{HB}	V _B	V
V _{IN}	Input Voltage IN Pin	-3	V _{CC}	V
T _J	Operating Junction Temperature Range	-40	125	°C

Functional operation above the stresses listed in the Recommended Operating Ranges is not implied. Extended exposure to stresses beyond the Recommended Operating Ranges limits may affect device reliability.

Table 5. ELECTRICAL CHARACTERISTICS (-40°C < T_J < 125°C, V_{CC} = V_B = 12 V, V_{HB} = GND, output is loaded with 1 nF, all voltages are referenced to GND, unless otherwise noted, Typical values are at T_J = 25°C.)

Symbol	Parameter	Test Condition	Min	Typ	Max	Unit
--------	-----------	----------------	-----	-----	-----	------

SUPPLY SECTION

I _{CC1}	V _{CC} Switching Current Consumption	f _{SW} = 100 kHz	-	100	150	μA
I _{B1}	V _B Switching Current Consumption	f _{SW} = 100 kHz	-	1.6	2.3	mA
I _{B1_noload}	V _B Switching Current Consumption	f _{SW} = 100 kHz, C _{LOAD} = 0 nF	-	0.2	0.5	mA
I _{CC2}	V _{CC} Quiescent Current Consumption	f _{SW} = 0 kHz, V _{IN} = 0 V	-	100	150	μA
I _{B2}	V _B Quiescent Current Consumption	f _{SW} = 0 kHz, V _{IN} = 0 V	-	85	150	μA
I _{HV_LEAK}	Leakage Current on High Voltage Pins to GND	V _{VB} = V _{HO} = V _{HB} = 130 V	-	2	5	μA

INPUT SECTION

V _{INL}	Input Falling Threshold		0.8	1.0	1.3	V
V _{INH}	Input Rising Threshold		1.0	1.7	2.3	V
V _{INHYS}	Input Voltage Hysteresis		0.2	0.7	-	V
R _{IN}	Input Pulldown Resistance	V _{IN} = 5 V	100	175	250	kΩ
I _{IN+}	Logic H Input Bias Current	V _{IN} = 5 V	-	30	50	μA
I _{IN-}	Logic L Input Bias Current	V _{IN} = 0 V	-	-	2	μA

UVLO SECTION

V _{CCCon}	V _{CC} UVLO Start_Up Voltage Threshold	V _{CC} Rising	5.8	6.4	7.0	V
V _{CCoff}	V _{CC} UVLO Shut_Down Voltage Threshold	V _{CC} Falling	5.3	5.9	6.5	V
V _{CChyst}	V _{CC} Hysteresis		0.2	0.5	-	V
V _{Bon}	V _B UVLO Start_Up Voltage Threshold	V _{Bon} = V _B - V _{HB} , V _B Rising	5.8	6.4	7.0	V
V _{Boff}	V _B UVLO Shut_Down Voltage Threshold	V _{Boff} = V _B - V _{HB} , V _B Falling	5.3	5.9	6.5	V
V _{Bhyst}	V _B Hysteresis		0.2	0.5	-	V
t _{startup}	High Side Startup Time	Time between V _B > V _{Bon} & 1 st HO Pulse	-	-	10	μs

OUTPUT SECTION

I _{HOsource}	Output High Short Circuit Pulsed Current (Note 4)	V _{HO} = 0 V, PW = 300 ns	-	2.0	-	A
I _{HOsink}	Output Low Short Circuit Pulsed Current (Note 4)	V _{HO} = V _B , PW = 300 ns	-	3.0	-	A
R _{OH}	Output Resistance Source	I _{HO} = 30 mA	-	2.0	7.0	Ω
R _{OL}	Output Resistance Sink	I _{HO} = 30 mA	-	1.0	5.0	Ω
V _{HOH}	High Level Output Voltage	V _{BIAS} - V _{HO} @ I _{HO} = 20 mA	-	0.06	0.25	V
V _{HOL}	Low Level Output Voltage	V _{HO} @ I _{HO} = 20 mA	-	0.04	0.15	V

OUTPUT RISE AND FALL TIME

t _r	Output Voltage Rise Time (from 10% to 90%)	V _{IN} = 3 V	-	11	30	ns
t _f	Output Voltage Fall Time (from 90% to 10%)	V _{IN} = 0 V	-	10	25	ns

NCP51313

Table 5. ELECTRICAL CHARACTERISTICS ($-40^{\circ}\text{C} < T_J < 125^{\circ}\text{C}$, $V_{CC} = V_B = 12\text{ V}$, $V_{HB} = \text{GND}$, output is loaded with 1 nF, all voltages are referenced to GND, unless otherwise noted, Typical values are at $T_J = 25^{\circ}\text{C}$.)

Symbol	Parameter	Test Condition	Min	Typ	Max	Unit
PROPAGATION DELAY NCP51313A						
t_{ON}	Turn On Propagation Delay	HB = 0 V, 50 V or 130 V, Cload = 0 nF, $V_{\text{IN}} = 3\text{ V}$	–	50	100	ns
t_{OFF}	Turn Off Propagation Delay	HB = 0 V, 50 V or 130 V, Cload = 0 nF	–	50	100	ns
t_{FLT}	Minimum Input Filter Time	$V_{\text{IN}} = 3\text{ V}$	20	30	–	ns
PROPAGATION DELAY NCP51313B						
t_{ON}	Turn On Propagation Delay	HB = 0 V, 50 V or 130 V, Cload = 0 nF, $V_{\text{IN}} = 3\text{ V}$	–	20	40	ns
t_{OFF}	Turn Off Propagation Delay	HB = 0 V, 50 V or 130 V, Cload = 0 nF	–	20	40	ns
OUTPUT PULSE WIDTH MATCHING NCP51313A						
PM	Output Mismatching	$V_{\text{IN}} = 3\text{ V}$, 1 μs pulse width	–	0	20	ns
OUTPUT PULSE WIDTH MATCHING NCP51313B						
PM	Output Mismatching	$V_{\text{IN}} = 3\text{ V}$, 1 μs pulse width	–	0	10	ns

Product parametric performance is indicated in the Electrical Characteristics for the listed test conditions, unless otherwise noted. Product performance may not be indicated by the Electrical Characteristics if operated under different conditions.

4. Parameter guaranteed by design.

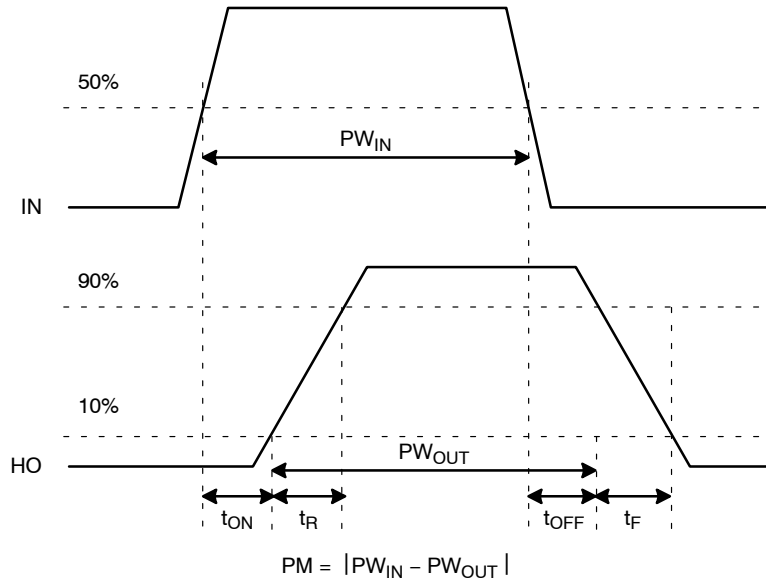

Figure 4. Propagation Delay, Rise and Fall Times, PM

NCP51313

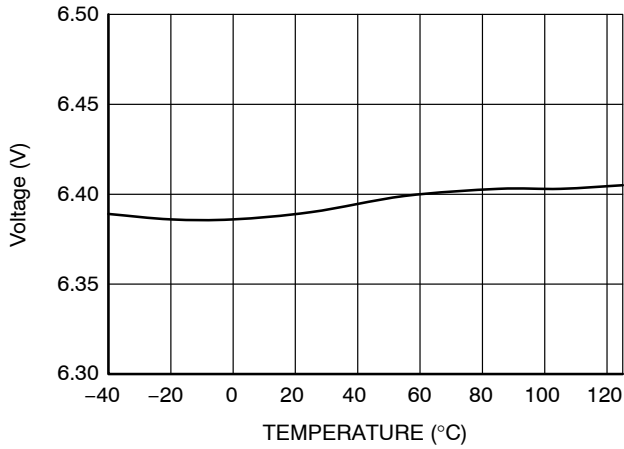

Figure 5. V_{CCon} vs. Temperature

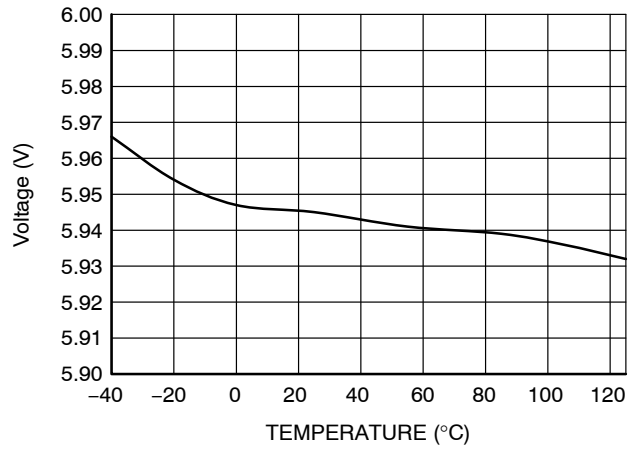

Figure 6. V_{CCoff} vs. Temperature

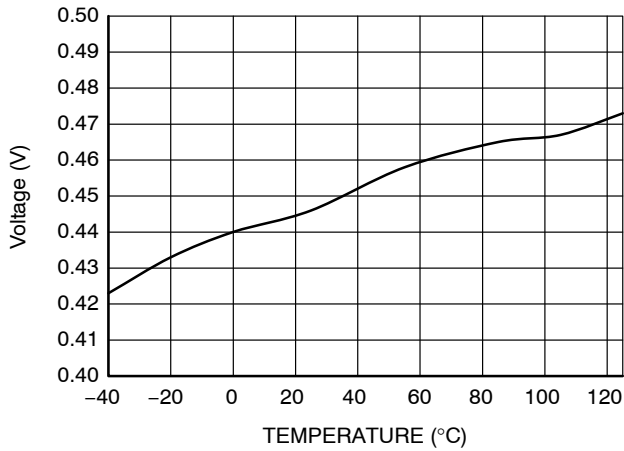

Figure 7. V_{CChyst} vs. Temperature

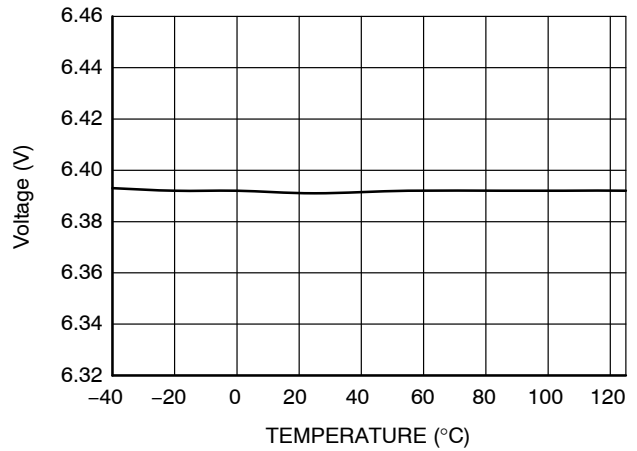

Figure 8. V_{Bon} vs. Temperature

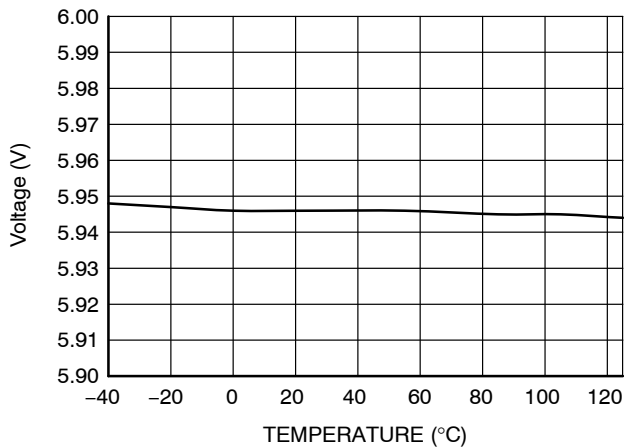

Figure 9. V_{Boff} vs. Temperature

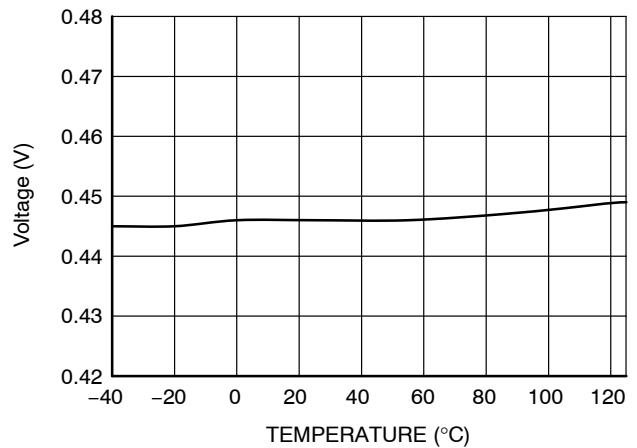

Figure 10. V_{Bhyst} vs. Temperature

NCP51313

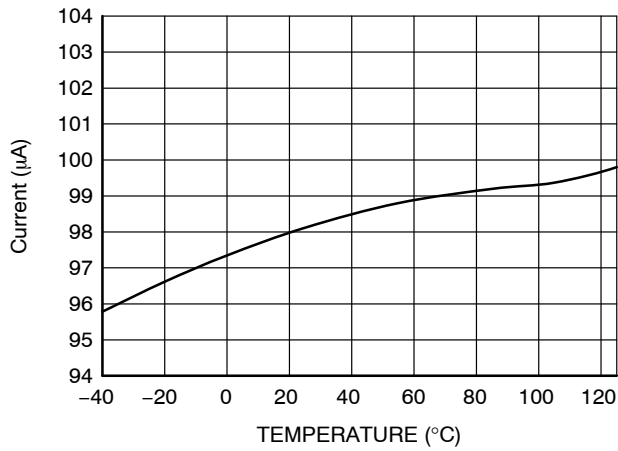

Figure 11. I_{CC1} vs. Temperature

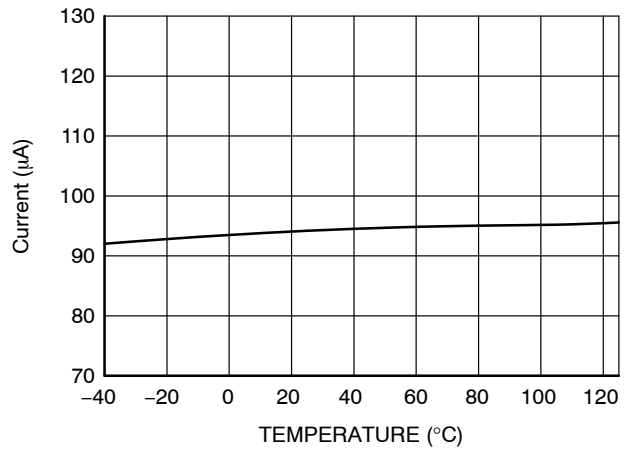

Figure 12. I_{CC2} vs. Temperature

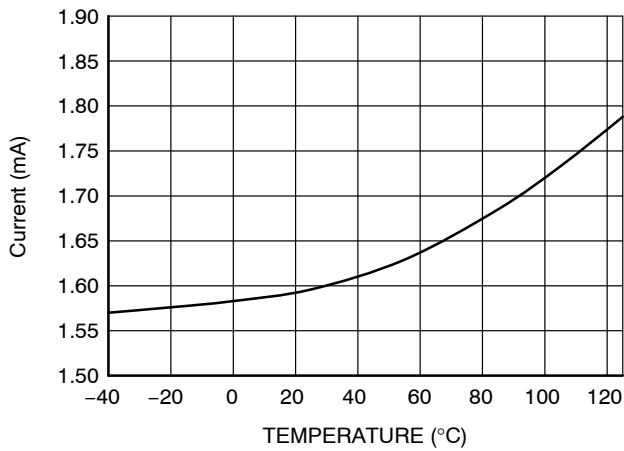

Figure 13. I_{B1} vs. Temperature

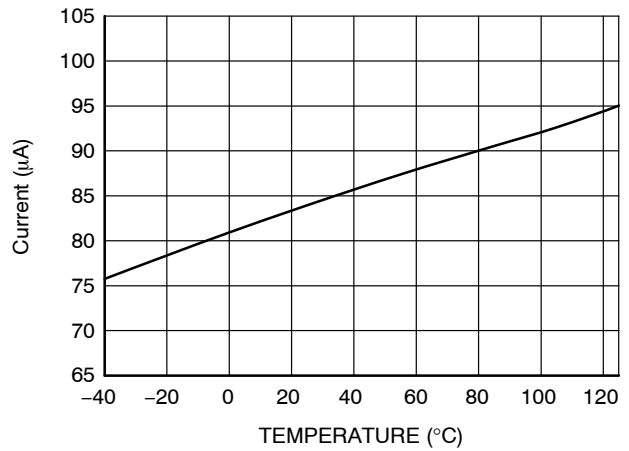

Figure 14. I_{B2} vs. Temperature

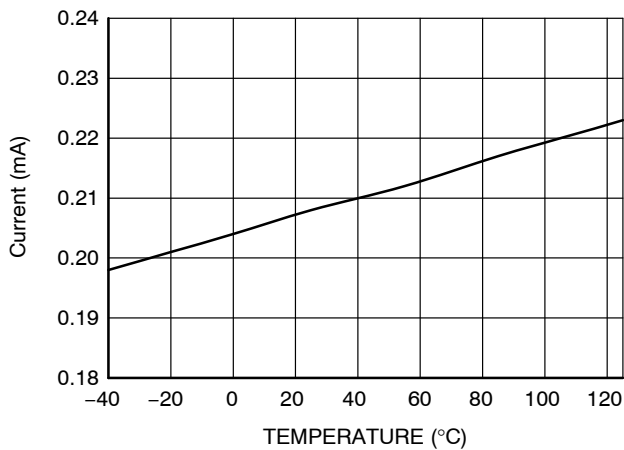

Figure 15. I_{B1_noload} vs. Temperature

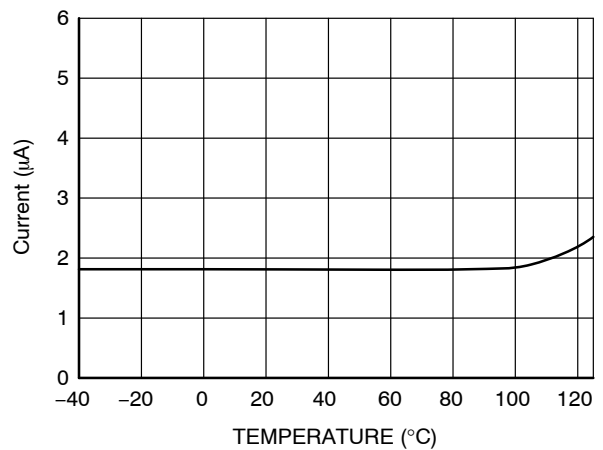

Figure 16. I_{HV_LEAK} vs. Temperature

NCP51313

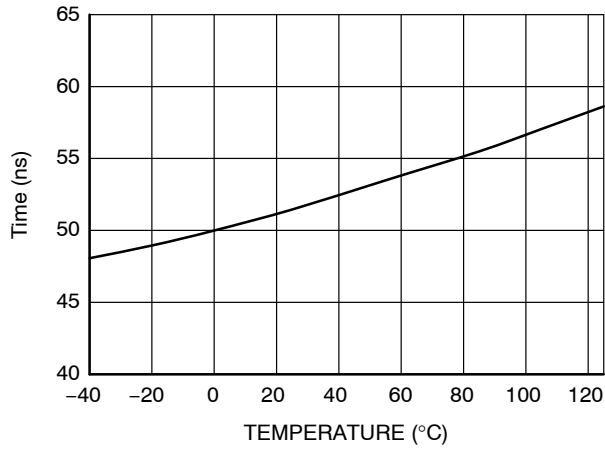

Figure 17. t_{ON} vs. Temperature

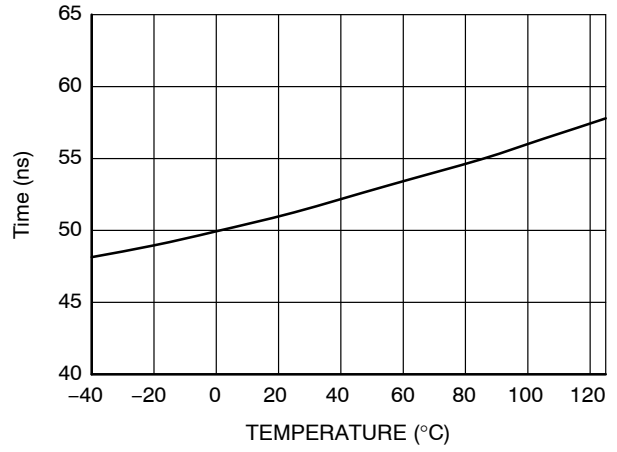

Figure 18. t_{OFF} vs. Temperature

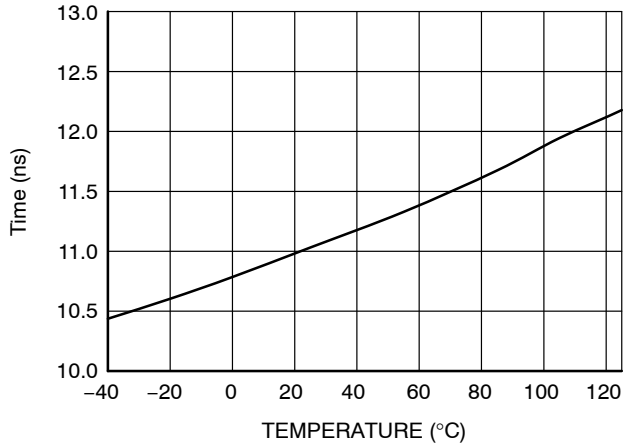

Figure 19. t_r vs. Temperature

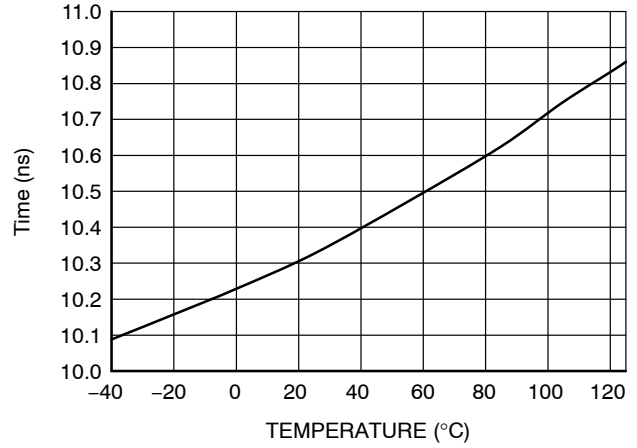

Figure 20. t_f vs. Temperature

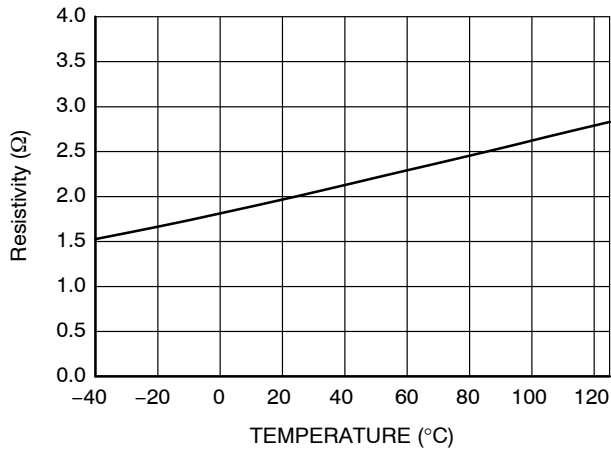

Figure 21. R_{OH} vs. Temperature

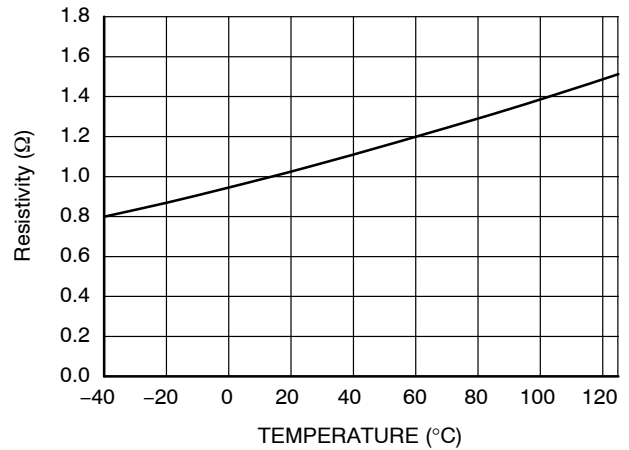

Figure 22. R_{OL} vs. Temperature

NCP51313

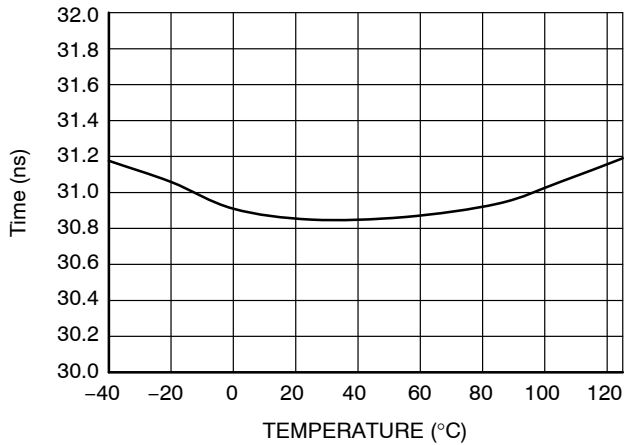

Figure 23. t_{FLT} vs. Temperature

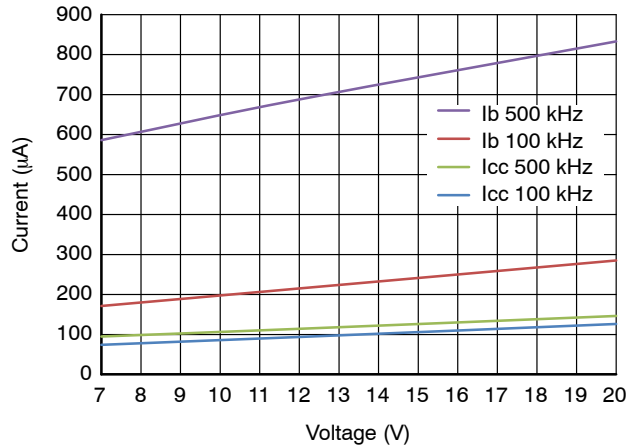

Figure 24. Current Consumption vs. Voltage, Load = 0 pF

GENERAL DESCRIPTION

For some popular topologies high-side drivers are needed which perform the function of both buffer and level shifter. These devices can drive the gate of the topside MOSFETs whose source node is a dynamically changing node. The bias for the high side driver in these devices is usually provided through a bootstrap circuit.

In a bid to make modern power supplies more compact and efficient, power supply designers are increasingly opting for high frequency operations. High frequency operation causes higher losses in the drivers, hence reducing the efficiency of the power supply.

NCP51313 is a 130 V high side driver for DC-DC power supplies and inverters. NCP51313 offers best in class propagation delay, low quiescent current and low switching current at high frequencies of operation. This device thus

enables highly efficient power supplies operating at high frequencies.

NCP51313 is offered in two versions, NCP51313A/B. NCP51313A has a typical 50 ns propagation delay, while NCP51313B has propagation delay of 20 ns.

NCP51313 has one input pin IN compatible with both CMOS and TTL logic allowing it to be used in a variety of applications. This device also includes features wherein, in case of floating input, the logic is still defined. NCP51313 has under voltage lock out feature which ensures operation at correct V_{CC} and V_B voltage levels. The output stage of NCP51313 has 2.0 A sourcing and 3.0 A sinking current which can effectively charge a 1 nF load in 11 ns and discharge a 1 nF load in 10 ns typically.

NCP51313

FEATURES

Input Stage

NCP51313 has one input pin IN. The input stages of NCP51313 are TTL and CMOS compatible. This ensures that the input of NCP51313 can be driven with 3.3 V or 5 V logic signals from analog or digital PWM controllers or logic gates.

The input pin has Schmitt trigger to avoid noise induced logic errors. The hysteresis on the input pin is typically 0.7 V. This high value ensures good noise immunity.

NCP51313 comes with an important feature wherein output (HO) stays low in case the input pin is floating. At the input pin there is an internal pull down resistor to define its

logic value in case the pin is left open or NCP51313 is driven by open drain signal.

NCP51313 input pin is also tolerant to negative voltage below the GND pin level as long as it is within the absolute maximum ratings value (see Table 2). This tolerance allows the use of transformer as an isolation barrier for input pulses.

NCP51313A features a noise rejection function to ensure that any pulse glitch shorter than 30 ns typically will not change HO level. These features are well illustrated in the Figure 25.

NCP51313B has no such filters in the input stages. The timing diagram of NCP51313B is Figure 26.

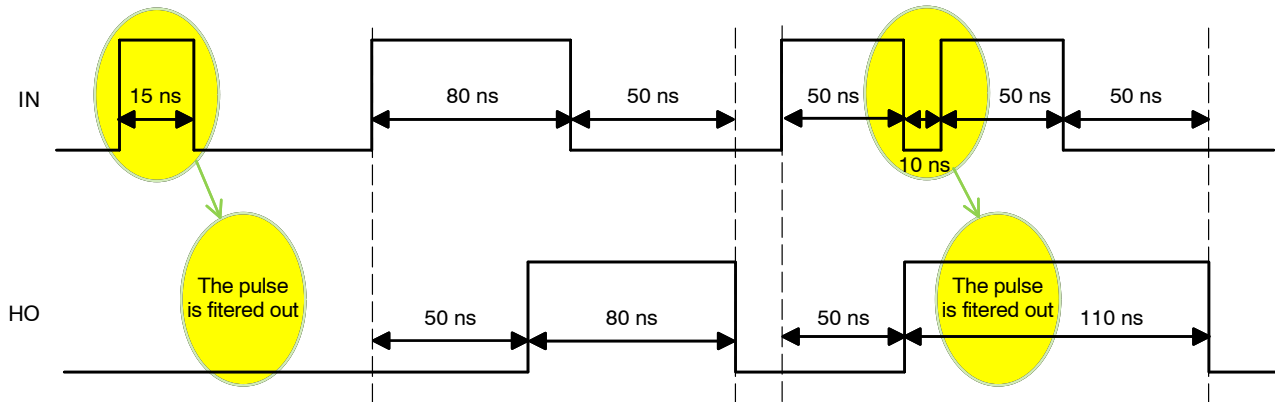

Figure 25. Input Filter (NCP51313A)

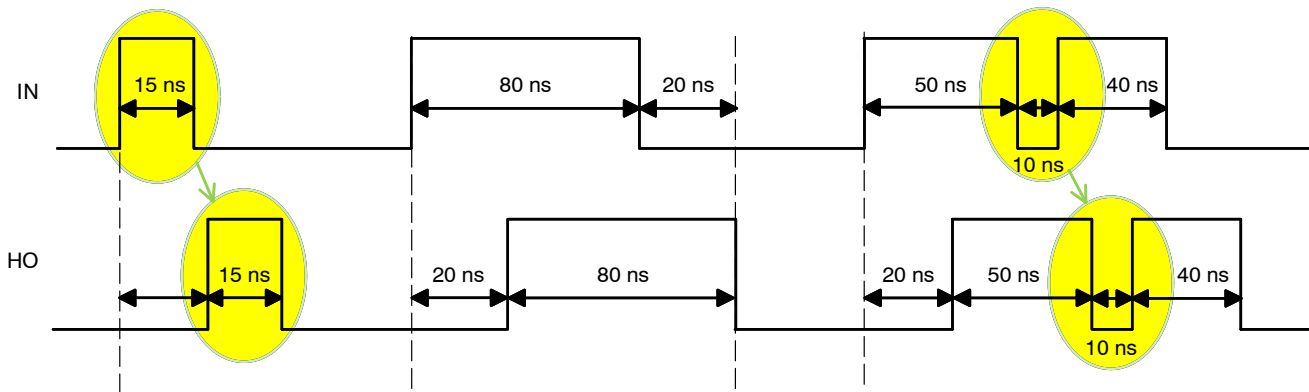
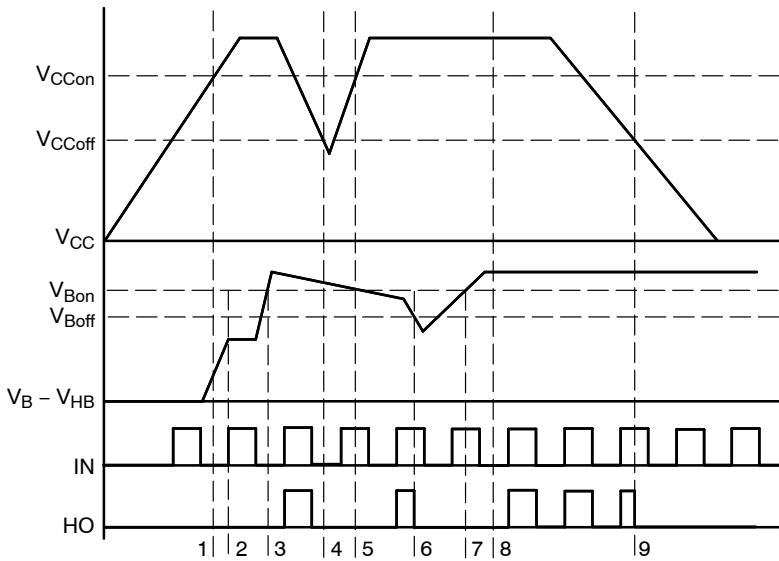

Figure 26. No Input Filter (NCP51313B)

NCP51313



Legend:

Let's assume, the driver is used in HB configuration.

1. Vcc crossed Vcon level. No action. A low side MOSFET is (or has been) turned on, current flows from Vcc to Cboot via bootstrap diode.
2. Cboot is not fully charged after first pulse. HO stays low.
3. Vb cross Vbon level. IN is in L, output stays in L. Vb and Vcc are above Vxon levels, pulses can pass the driver.
4. Vccoff level is crossed, no pulses can pass the driver.
5. Vcon level crossed, Vbon has been crossed earlier, the current pulse is not transferred.
6. Vboff level is crossed while HO is H. HO is set to L immediately.
7. Vbon level crossed. Current (ongoing) pulse is ignored.
8. Vcc and Vb voltage are above Vxon level, all pulses can pass the driver. Steady state conditions.
9. Vccoff level is crossed while HO is in H. HO is set to L immediately. From now on, no pulse will pass the driver.

Figure 27. UVLO Timing Diagram

Under Voltage Lock-out

NCP51313 has under voltage lockout protection. The function of the UVLO circuits is to ensure that there is enough supply voltages (V_{CC} and V_B) to correctly bias driver circuit. This also ensures that the gate of external MOSFET is driven at an optimum voltage.

If the V_{CC} or V_B is below the V_{CC} UVLO voltage, high side driver output (HO) remains low. Both the V_{CC} and V_B UVLO

circuits are provided with hysteresis feature. This hysteresis feature avoids errors due to ground noise in the power supply. The hysteresis also ensures continuous operation in case of a small drop in the bias voltage. This drop in the bias can happen when device starts switching MOSFET and the operating current of the device increases. The UVLO feature of the device is explained in the Figure 27.

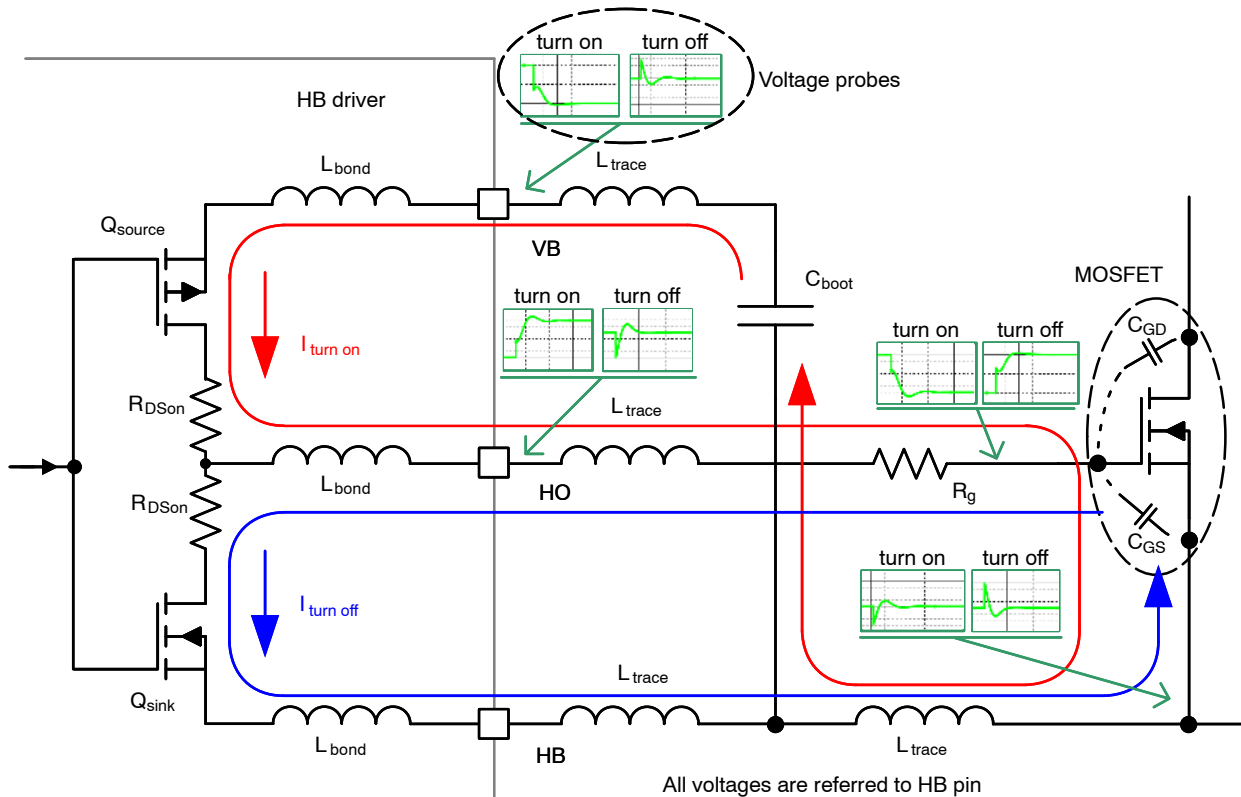

Figure 28. NCP51313 Turn ON-OFF Paths

NCP51313

Output Stages

The NCP51313 is equipped with a floating driver. The output stage of NCP51313 has 2.0 A source and 3.0 A sink current capability which can effectively charge a 1 nF load in 11 ns and discharge a 1 nF load in 10 ns typically.

Figure 28 shows the output stage structure and the charging and discharging path of the external power MOSFET and the bias supply V_B , the energy to charge the gate capacitance C_{GS} . When a logic high is received from input stage, Q_{source} turns on and V_B starts to charge C_{GS} through R_g . Once the C_{GS} is charged the external power MOSFET is conductive.

When a logic low signal is received from the input stage, Q_{source} turns off and Q_{sink} turns on providing discharge path for gate terminal. As seen in the figure, there are parasitic inductances in charging and discharging path of the C_{GS} . This can result in a little dip in the bias voltage V_B . If the V_B drops below $UVLO$ the power supply can shut down the device.

Short Propagation Delay

NCP51313 boasts of industry best propagation delay between input and output. NCP51313A has a typical of

50 ns propagation delay. The best in class propagation delay in NCP51313 makes it suitable for high frequency operation.

Since NCP51313B doesn't have the input filter included, the propagation delay is even shorter. NCP51313B offers 20 ns propagation delay between input and output.

The device allows 100 % duty cycle operation. The HO can be continuously in H or L state. In such case it is necessary to have a floating source to supply floating driver when using the driver under 100% DC.

Negative Transient Immunity (NTI) Operating Conditions

In any HB switching applications the HB node is often pulled under the ground during the switching operation because of parasitic inductances and inductive load. These negative spikes may lead to malfunction or damage of the circuit.

The capability of NCP51313 to operate under negative voltage conditions is reported in NTI graph using below test set up.

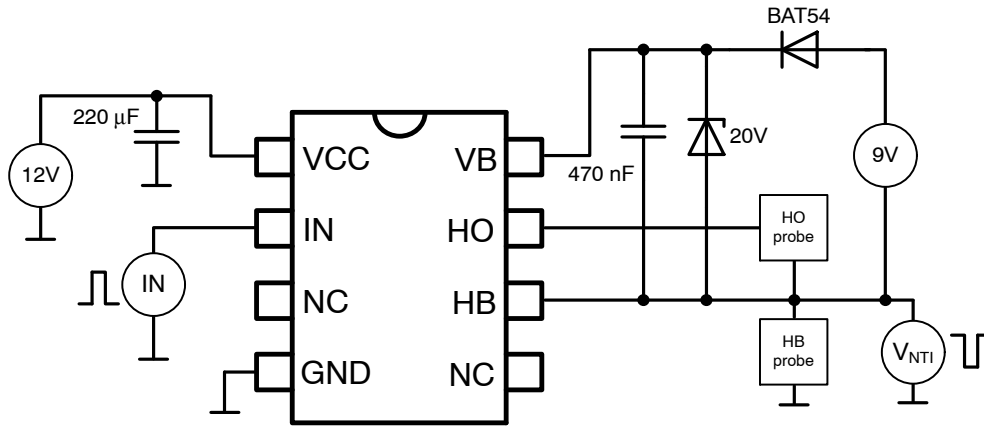

Figure 29. NTI Test Set Up

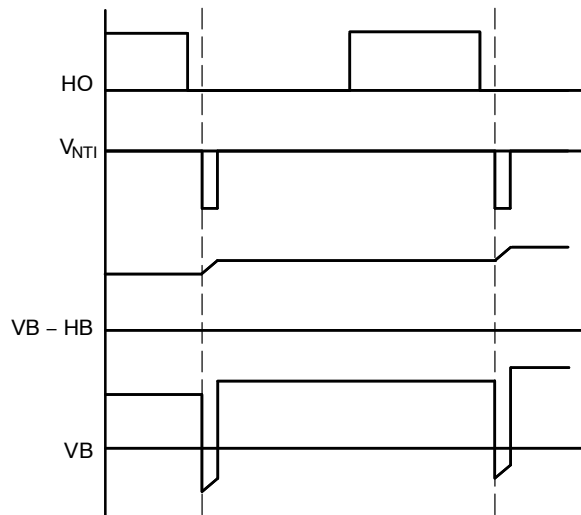

Figure 30. Timing Diagram

NCP51313

NCP51313 robustness against negative spikes is shown in Figure 31. The result is a curve which shows negative

voltage level for specific pulse width under which driver could still operate properly.

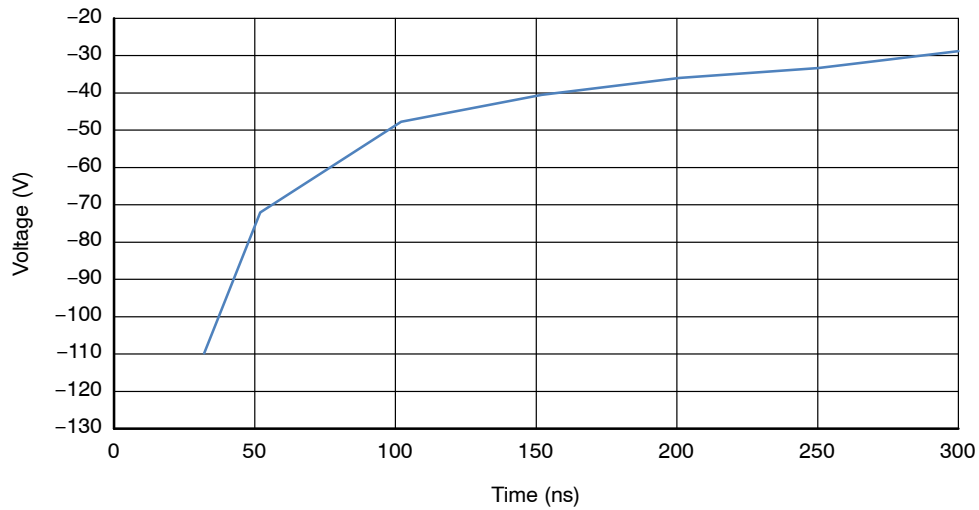

Figure 31. Indicative Negative Transient Immunity

IMPORTANT NOTE:

Even though above figure shows that NCP51313 is able to handle negative transient voltage conditions, it is highly recommended that the application circuit design is such that

it removes or at least always limit the negative transient voltage on VB pin as much as possible via careful PCB layout and proper component selection.

COMPONENT SELECTION

C_{boot} Capacitor Value Calculation

NCP51313 has one floating driver for driving high side external MOSFET. The bias for the high side driver is

usually provided through a bootstrap circuit. A typical bootstrap circuit is shown in the Figure 32.

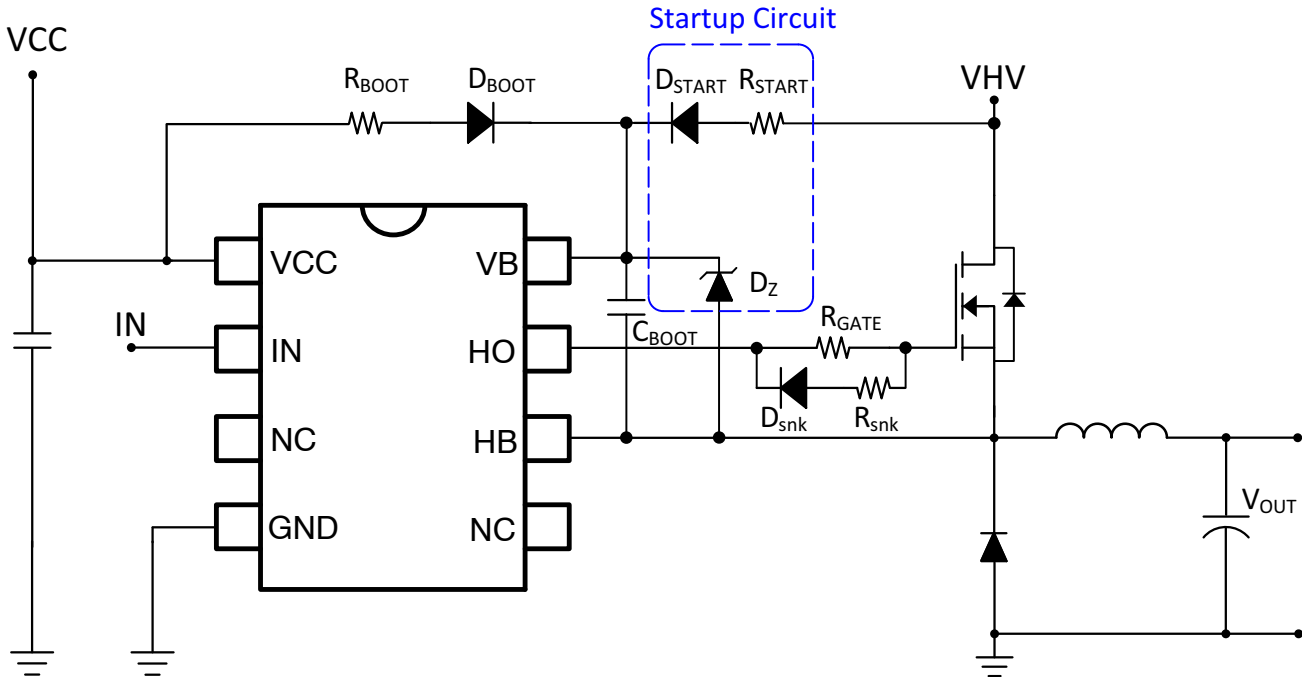

Figure 32. Bootstrap with Startup Circuit

The high side driver is biased by the C_{BOOT} (bootstrap capacitor). As can be seen in the circuit, C_{BOOT} will charge only when HB goes to GND level. Low value of C_{BOOT} can result in a little dip in the bias voltages V_B. If the V_B drops below UVLO level the power supply can shut down the driver. Therefore choosing the right value of C_{boot} is very important for a robust design.

In the beginning of the operation, HO cannot response if C_{BOOT} is not charged above V_{Bon} level, referenced to voltage between VB and HB pin.

Therefore, if there is no initial charging switch on low side, an additional start-up circuit should be considered for high side driver to ensure starting of the operation.

The start-up circuit, as shown in the Figure 32, consists of a startup resistor (R_{START}), a startup diode (D_{START}), and a Zener diode (D_Z). In this startup circuit, startup diode D_{START} serves as a second bootstrap diode used for charging the bootstrap capacitor (C_{BOOT}) at power up. Bootstrap capacitor (C_{BOOT}) is charged to the Zener diode of D_Z, which is supposed to be higher than the driver's supply voltage (V_{CC}) during normal operation. The charge current of the bootstrap capacitor and the Zener current are limited by the startup resistor. For best efficiency, the value of startup resistor should be selected to limit the current to a low value, since the bootstrap path through the startup diode is permanently in the circuit.

Expected voltage on C_{BOOT} pin in steady state condition is depicted in Figure 33.

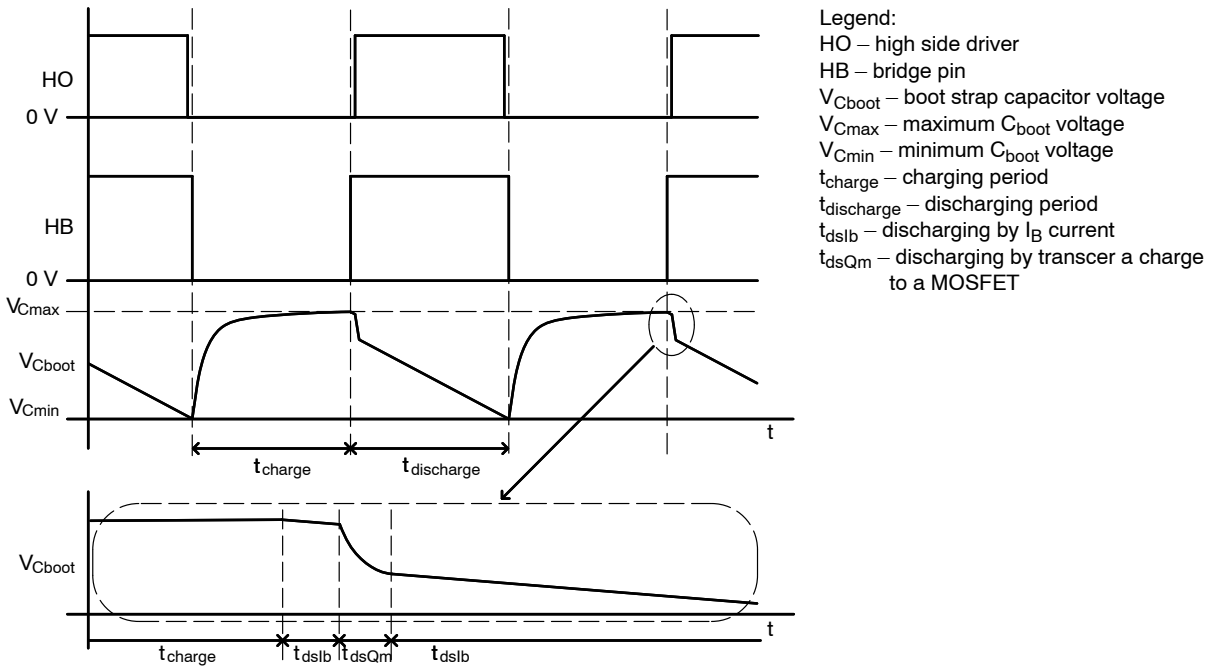

Figure 33. Boot Strap Capacitor Charging and Discharging

The curves are valid for ZVS (Zero Voltage Switching) observed in LLC applications. For hard switch the curves are slightly different, but from charge on C_{boot} point of view more favorable. Under the hard switch conditions the energy to charge Q_g (from zero voltage to V_{th} of the MOSFET) is taken from V_{CC} capacitor (through an external boot strap diode) so the voltage drop on C_{boot} is smaller. For the calculation of C_{boot} value the ZVS conditions are taken account.

The switching cycle is divided into two parts, the charging (t_{charge}) and the discharging ($t_{discharge}$) of the C_{boot} capacitor. The discharging can be divided even more to discharging by floating driver current consumption I_{B2} (t_{dsib}), and to discharging by transferring energy from C_{boot} to gate terminal of the MOSFET (t_{dsQm}) and discharging by leakage current of the bootstrap diode (not taken account). Discharging by I_{B2} becoming more dominant when driver runs at lower frequencies and/or during skip mode operation. To calculate C_{boot} value, follow these steps:

1. For example, let's have a MOSFET with $Q_g = 49 \text{ nC}$, $V_{CC} = 10 \text{ V}$.
2. Charge stored in C_{boot} necessary to cover the period the C_{boot} is not supplied from V_{CC} line (which is basically the period the high side MOSFET is turned on). Let's say the application is switching at 100 kHz, 50 % duty cycle, which means the upper MOSFET is conductive for 5 μs . It means the C_{boot} is discharged by I_{B2} current (100 μA typ) for 5 μs , so the charge consumed by floating driver is:

$$Q_b = I_{B2} \cdot t_{discharge} = 10 \mu \cdot 5 \mu = 500 \text{ pC} \quad (\text{eq. 1})$$

3. Total charge loss during one switching cycle is sum of charge to supply the high side driver and MOSFET's gate charge:

$$Q_{tot} = Q_g + Q_b = 49 \text{ n} + 500 \text{ p} = 49.5 \text{ nC} \quad (\text{eq. 2})$$

4. Let's determine acceptable voltage ripple on C_{boot} to 1 % of nominal value, which is 100 mV. To cover charge losses from eq. 2.

$$C_{boot} = \frac{Q_{tot}}{V_{ripple}} = \frac{49.5 \text{ n}}{0.1} = 495 \text{ nF} \quad (\text{eq. 3})$$

- Q_g is equivalent gate charge of the MOSFET
- I_{B2} is the boot quiescent current
- $t_{discharge}$ is the on time for HO
- V_{ripple} is the allowed ripple voltage in the bootstrap capacitor

It is recommended to use a larger value so as to cover any variations in the gate charge and voltage with temperature.

R_{boot} Resistor Value Calculation

To keep the application running properly, it is necessary to charge the C_{boot} again. This is done by external diode from V_{CC} line to V_B pin. In serial with the diode a resistor is placed to reduce the current peaks from V_{CC} line. The resistor value selection is critical for proper function of the high side driver. If too small high current peaks are drawn from V_{CC} line, if too high the capacitor will not be charged to appropriate level and the high side driver can be disabled by internal UVLO protection.

First of all keep in mind the capacitor is charged through the external bootstrap diode, so it can be charged to a maximum voltage level of $V_{CC} - V_f$. The resistor value is calculated using this equation:

$$R_{boot} = \frac{C_{charge}}{C_{boot} \cdot \ln\left(\frac{V_{max} - V_{Cmin}}{V_{max} - V_{Cmax}}\right)} = \frac{5 \mu}{1 \mu \cdot \ln\left(\frac{9.4 - 9.25}{9.4 - 9.35}\right)} \approx 4.6 \Omega \quad (\text{eq. 4})$$

Where:

- t_{charge} time period the Cboot is being charged, usually the period the low side MOSFET is turned on,
- C_{boot} boot strap capacitor value
- V_{max} maximum voltage the C_{boot} capacitor can be theoretically charged to. Usually the $V_{CC} - V_f$. The V_f is forward voltage of used diode
- V_{Cmin} the voltage level the capacitor is charge from
- V_{Cmax} the voltage level the capacitor is charged to. It is necessary to determine the target voltage for charging, because in theory, when a capacitor is charged from a voltage source through a resistor, the capacitor can never reach the voltage of the source. In this particular case a 50 mV difference (between the voltage behind the diode and V_{Cmax}) is used.

The resistor value obtained from eq. 4 does not count with the quiescent current I_{B2} of the high side driver. This current will create another voltage drop of:

$$B_{IB2_drop} = R_{boot} \cdot I_{B2} = 4.6 \cdot 100 \mu \approx 460 \mu V \quad (\text{eq. 5})$$

The current consumed by high side driver will be higher, because the I_{B2} is valid when the device is not switching. While switching, losses by charging and discharging internal transistors as well as the level shifters will be added. This current will increase with frequency.

The additional 460 μV drop will be added to V_{Cmax} value. The additional 460 μV drop can be either accepted or the R_{boot} value can be recalculated to eliminate this additional drop.

The resistor R_{boot} calculated in eq. 4 is valid under steady state conditions. During start and/or skip operation the starting point voltage value is different (lower) and it takes more time to charge the boot strap capacitor. More over it is not counted with temperature and voltage variability during normal operation or the dynamic resistance of the boot strap diode (approximately 0.34 Ω for MURA160). From these reasons the resistor value should be decreased especially with respect to skip operation.

Boot strap resistor loss calculation.

$$P_{Rboot} \approx Q_{tot} \cdot V_{max} \cdot f \approx 49.5 n \cdot 9.4 \cdot 100 k \approx 46.3 mW \quad (\text{eq. 6})$$

Boot strap diode loss calculation.

$$P_{Dboot} \approx Q_{tot} \cdot V_f \cdot f \approx 49.5 n \cdot 0.6 \cdot 100 k \approx 3 mW \quad (\text{eq. 7})$$

Please keep in mind the value is temperature and voltage dependent. Especially C_{boot} voltage can be higher than calculated value. Also keep in mind, the Boot strap resistor power dissipation calculated in eq. 6 is valid for steady state conditions. For first Cboot charging, the power loss (the current) is much higher.

$$I_{Rboot} = \frac{C_{Vcc} - V_{Dboot} - V_{Cboot}}{R_{boot}} = \frac{10 - 0.6 - 0}{4.6} \approx 2 A \quad (\text{eq. 8})$$

$$P_{Rboot} = (C_{Vcc} - V_{Dboot} - V_{Cboot}) \cdot I_{Rboot} \approx (10 - 0.6 - 0) \cdot 2 \approx 18.8 W \quad (\text{eq. 9})$$

The Boot strap resistor must be designed to accept the current from eq. 8 and power loss from eq. 9 for a while.

VCC Capacitor Selection

V_{CC} capacitor value should be selected at least ten times the value of C_{boot} . In this case thus $C_{Vcc} > 10 \mu F$.

IN Pin Input Filter

For PWM connection on the IN pin of the NCP51313, an RC filter can help to filter out high frequency input noise.

This filter is particularly important in case of NCP51313B where no internal filter is included.

The recommended value for R_{IN} and C_{IN} are as below.

$$R_{IN} = 100 \Omega$$

$$C_{IN} = 120 pF$$

Rgate Selection

The R_{gate} are selected to limit the peak gate current during charging and discharging of the gate capacitance. This resistance also helps to damp the ringing due to the parasitic inductances, reduce dV/dt on HB pin to safe level and attenuate EMI radiation. If high dV/dt (during rise/fall edge and/or ringing after switching) is applied on HB pin, it can cause unexpected behavior of the driver.

On the other hand, too high resistor will increase power loss on MOSFETs, which leads to lower efficiency. It is recommended to start evaluation with a high resistor value and decrease the value if behavior is safe under all conditions. We recommend to have at least a 4.7 Ω resistor between NCP51313 outputs and MOSFET's gate.

The resistors also help to decrease power dissipation of the driver, because part of the energy from charging and discharging C_{gs} is radiated on the resistors R_{gate} (and on R_{snk} if they are used) outside the driver see Figure 32. The gate resistor selection is tricky task. It depends on application, topology, on used MOSFETs, layout etc.

For example for R_{gate} value of 4.7 Ω , the peak source and sink currents would be limited to the following values.

$$R_{GATE} = 4.7 \Omega$$

$$I_{HO_Source} = \frac{V_B}{R_{gate} + R_{OH} + R_g} = \frac{10}{7.7} \approx 1.3 A \quad (\text{eq. 10})$$

$$I_{HO_Sink} = \frac{V_B}{R_{gate} + R_{OL} + R_g} = \frac{10}{6.7} \cong 1.5 \text{ A} \quad (\text{eq. 11})$$

Where:

R_{OH} R_{DSon} of internal source MOSFET (see parametric table R_{OH} parameter)

R_{OL} R_{DSon} of internal sink MOSFET (see parametric table R_{OL} parameter)

R_g internal gate resistance of external MOSFET (see appropriate DS), in this case 1 Ω .

In some applications it is desired/advantageous to use separated current paths for charging and discharging the gate capacitance. For this purpose external MOSFET gate connection must be extended (see Figure 32). Two components R_{snk} and D_{snk} can be added in parallel to R_{gate} resistor. The charging path is now only through R_{gate} resistor, while discharging path is through R_{snk} and R_{gate} in parallel combination. Consider both resistors are the same value 10 Ω . The source current is calculated using eq. 10. The current is 769 mA.

$$I_{HO_Sink} = \frac{V_B}{R_{gate} + (R_{OL} + R_g) \cdot 2} + \frac{V_B - V_{Dsnk}}{R_{snk} + (R_{OL} + R_g) \cdot 2} = \frac{9.4}{12} + \frac{8.8}{12} \cong 1.52 \text{ A} \quad (\text{eq. 12})$$

Total Power Dissipation

Total power dissipation of NCP51313 is sum of partial dissipations which can be calculated as follows (for more details, please refer to [AND90004/D](#)).

1. Power loss of device (except drivers) while switching at appropriate frequency is calculated from current consumption at given voltage for specific frequency. The current can be estimated from Figure 24, or it could be calculated using these formulas:

$$I_{CCnoload} = -5.72 \cdot 10^{-6} \cdot V \cdot f + 51.4 \cdot 10^{-3} \cdot f + 3.98 \cdot V + 40.96 \quad (\text{eq. 13})$$

$$I_{Bnoload} = 25.8 \cdot 10^{-3} \cdot V \cdot f + 0.866 \cdot f + 5.93 \cdot V + 22.51 \quad (\text{eq. 14})$$

Where:

f is frequency in kHz,

V is voltage in V,

Calculated current will be in μA .

The power dissipation of device (without drivers) is equal to.

$$\begin{aligned} P_{logic} &= P_{HS} + P_{LS} = \\ &= (V_{boot} \cdot I_{Bnoload}) + (V_{CC} \cdot I_{CCnoload}) = \\ &= (9.4 \cdot 189 \cdot 10^{-6}) + (10 \cdot 86 \cdot 10^{-6}) = \\ &= 2.6 \text{ mW} \end{aligned} \quad (\text{eq. 15})$$

2. Power loss of driver

$$\begin{aligned} P_{driver} &= (Q_g \cdot V_B) \cdot f = \\ &= (49 \cdot 10^{-9} \cdot 9.4) \cdot 100 \cdot 10^3 \cong 46 \text{ mW} \end{aligned} \quad (\text{eq. 16})$$

Q_g is total gate charge of the used MOSFET.

3. Level shifter power loss

$$\begin{aligned} P_{lvshft} &= (V_{HV} + V_B) \cdot f \cdot (Q_S + Q_R) = \\ &= (100 + 9.4) \cdot 100 \cdot 10^3 \cdot \\ &\cdot (166 + 166) \cdot 10^{-12} \cong 3.6 \text{ mW} \end{aligned} \quad (\text{eq. 17})$$

Where:

V_{HV} is DC link voltage, here 100 V,

V_B is boot strap voltage, here 9.6 V,

f is switching frequency, here 100 kHz,

Q_S, Q_R is energy needed to transfer information from LS part to HS part of the driver. The worst case is ZVS mode. In hard switch mode is Q_S very small, as the set pulse comes when HB pin is on low voltage.

4. HS leakage power loss

$$\begin{aligned} P_{leak} &= I_{HV,LEAK} \cdot (V_{HV} + V_B) \cdot DC = \\ &= 2 \cdot 10^{-6} \cdot (100 + 9.4) \cdot 0.5 \cong 0.1 \text{ mW} \end{aligned} \quad (\text{eq. 18})$$

Where:

V_{HV} is DC link voltage, here 100 V,

V_B is boot strap voltage, here 9.4 V,

DC is duty cycle, here 50 %.

5. Total Power Loss (Hard Switching)

$$\begin{aligned} P_{total} &= P_{logic} + P_{driver} + P_{lvshft} + P_{leak} = \\ &= (2.6 + 46 + 3.6 + 0.1) \cdot 10^{-3} \cong 52.3 \text{ mW} \end{aligned} \quad (\text{eq. 19})$$

Increasing Junction temperature (t_j) compared to Ambient temperature (t_a) is

$$t_j = R_{tjA} \cdot P_{total} = 130 \cdot 0.052 \cong 6.8 \text{ K} \quad (\text{eq. 20})$$

The temperature calculated in eq. 20 is the value which has to be added to ambient temperature. In case the ambient temperature is 30°C, the junction temperature will be 36.8°C.

NCP51313

PACKAGE DIMENSIONS

SOIC-8 NB CASE 751-07 ISSUE AK

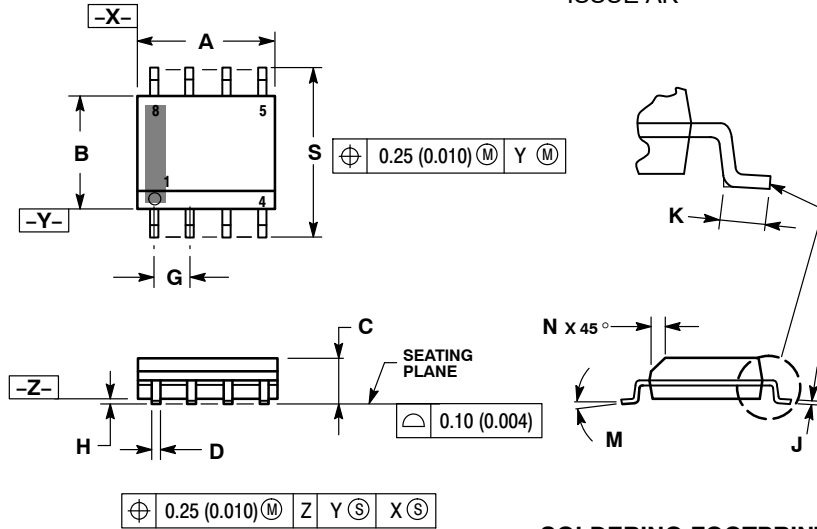

NOTES:

1. DIMENSIONING AND TOLERANCING PER ANSI Y14.5M, 1982.
2. CONTROLLING DIMENSION: MILLIMETER.
3. DIMENSION A AND B DO NOT INCLUDE MOLD PROTRUSION.
4. MAXIMUM MOLD PROTRUSION 0.15 (0.006) PER SIDE.
5. DIMENSION D DOES NOT INCLUDE DAMBAR PROTRUSION. ALLOWABLE DAMBAR PROTRUSION SHALL BE 0.127 (0.005) TOTAL IN EXCESS OF THE D DIMENSION AT MAXIMUM MATERIAL CONDITION.
6. 751-01 THRU 751-06 ARE OBSOLETE. NEW STANDARD IS 751-07.

DIM	MILLIMETERS		INCHES	
	MIN	MAX	MIN	MAX
A	4.80	5.00	0.189	0.197
B	3.80	4.00	0.150	0.157
C	1.35	1.75	0.053	0.069
D	0.33	0.51	0.013	0.020
G	1.27 BSC		0.050 BSC	
H	0.10	0.25	0.004	0.010
J	0.19	0.25	0.007	0.010
K	0.40	1.27	0.016	0.050
M	0°	8°	0°	8°
N	0.25	0.50	0.010	0.020
S	5.80	6.20	0.228	0.244

SOLDERING FOOTPRINT*

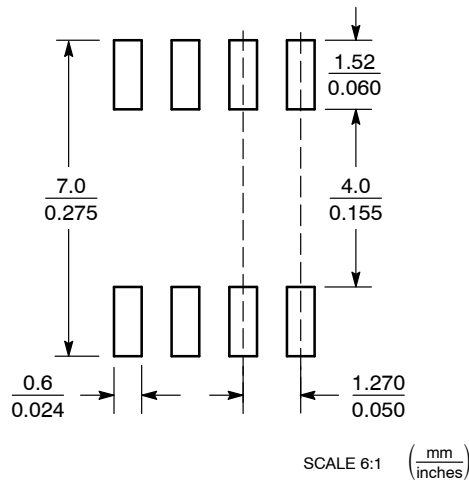

*For additional information on our Pb-Free strategy and soldering details, please download the **onsemi** Soldering and Mounting Techniques Reference Manual, SOLDERRM/D.

onsemi, **Onsemi**, and other names, marks, and brands are registered and/or common law trademarks of Semiconductor Components Industries, LLC dba "**onsemi**" or its affiliates and/or subsidiaries in the United States and/or other countries. **onsemi** owns the rights to a number of patents, trademarks, copyrights, trade secrets, and other intellectual property. A listing of **onsemi**'s product/patent coverage may be accessed at www.onsemi.com/site/pdf/Patent-Marking.pdf. **onsemi** reserves the right to make changes at any time to any products or information herein, without notice. The information herein is provided "as-is" and **onsemi** makes no warranty, representation or guarantee regarding the accuracy of the information, product features, availability, functionality, or suitability of its products for any particular purpose, nor does **onsemi** assume any liability arising out of the application or use of any product or circuit, and specifically disclaims any and all liability, including without limitation special, consequential or incidental damages. Buyer is responsible for its products and applications using **onsemi** products, including compliance with all laws, regulations and safety requirements or standards, regardless of any support or applications information provided by **onsemi**. "Typical" parameters which may be provided in **onsemi** data sheets and/or specifications can and do vary in different applications and actual performance may vary over time. All operating parameters, including "Typicals" must be validated for each customer application by customer's technical experts. **onsemi** does not convey any license under any of its intellectual property rights nor the rights of others. **onsemi** products are not designed, intended, or authorized for use as a critical component in life support systems or any FDA Class 3 medical devices or medical devices with a same or similar classification in a foreign jurisdiction or any devices intended for implantation in the human body. Should Buyer purchase or use **onsemi** products for any such unintended or unauthorized application, Buyer shall indemnify and hold **onsemi** and its officers, employees, subsidiaries, affiliates, and distributors harmless against all claims, costs, damages, and expenses, and reasonable attorney fees arising out of, directly or indirectly, any claim of personal injury or death associated with such unintended or unauthorized use, even if such claim alleges that **onsemi** was negligent regarding the design or manufacture of the part. **onsemi** is an Equal Opportunity/Affirmative Action Employer. This literature is subject to all applicable copyright laws and is not for resale in any manner.

ADDITIONAL INFORMATION

TECHNICAL PUBLICATIONS:
 Technical Library: www.onsemi.com/design/resources/technical-documentation
 onsemi Website: www.onsemi.com

ONLINE SUPPORT: www.onsemi.com/support
 For additional information, please contact your local Sales Representative at www.onsemi.com/support/sales