

NCV7341

High Speed Low Power CAN Transceiver

The NCV7341 CAN transceiver is the interface between a controller area network (CAN) protocol controller and the physical bus and may be used in both 12 V and 24 V systems. The transceiver provides differential transmit capability to the bus and differential receive capability to the CAN controller.

Due to the wide common-mode voltage range of the receiver inputs, the NCV7341 is able to reach outstanding levels of electromagnetic susceptibility (EMS). Similarly, extremely low electromagnetic emission (EME) is achieved by the excellent matching of the output signals.

The NCV7341 is a new addition to the ON Semiconductor CAN high-speed transceiver family and offers the following additional features:

Features

- Ideal Passive Behavior when Supply Voltage is Removed
- Separate V_{IO} Supply for Digital Interface Allowing Communication to CAN Controllers and Microcontrollers with Different Supply Levels
- Fully Compatible with the ISO 11898 Standard
- High Speed (up to 1 Mb)
- Very Low Electromagnetic Emission (EME)
- V_{SPLIT} Voltage Source for Stabilizing the Recessive Bus Level if Split Termination is Used (Further Improvement of EME)
- Differential Receiver with High Common-Mode Range for Electromagnetic Immunity (EMI)
- Up to 110 Nodes can be Connected in Function of the Bus Topology
- Transmit Data (TxD) Dominant Time-out Function
- Bus Error Detection with Version NCV7341D20
- Bus Pins Protected Against Transients in Automotive Environments
- Bus Pins and Pin V_{SPLIT} Short-Circuit Proof to Battery and Ground
- Thermally Protected
- NCV Prefix for Automotive and Other Applications Requiring Site and Change Controls
- These are Pb-Free Devices*

Typical Applications

- Automotive
- Industrial Networks

*For additional information on our Pb-Free strategy and soldering details, please download the ON Semiconductor Soldering and Mounting Techniques Reference Manual, SOLDERRM/D.



ON Semiconductor®

<http://onsemi.com>

PIN ASSIGNMENT

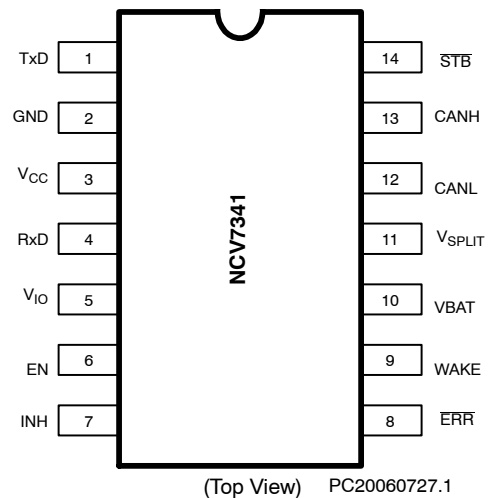

ORDERING INFORMATION

See detailed ordering and shipping information in the package dimensions section on page 17 of this data sheet.

NCV7341

Table 1. TECHNICAL CHARACTERISTICS

Symbol	Parameter	Condition	Max	Max	Unit
V _{CC}	Supply Voltage for the Core Circuitry		4.75	5.25	V
V _{IO}	Supply Voltage for the Digital Interface		2.8	5.25	V
V _{EN}	DC Voltage at Pin EN		-0.3	V _{IO} + 0.3	V
\overline{V}_{STB}	DC Voltage at Pin \overline{STB}		-0.3	V _{IO} + 0.3	V
V _{TxD}	DC Voltage at Pin TxD		-0.3	V _{IO} + 0.3	V
V _{RxD}	DC Voltage at Pin RxD		-0.3	V _{IO} + 0.3	V
\overline{V}_{ERR}	DC Voltage at Pin \overline{ERR}		-0.3	V _{IO} + 0.3	V
V _{CANH}	DC Voltage at Pin CANH	0 < V _{CC} < 5.25 V; No Time Limit	-58	+58	V
V _{CANL}	DC Voltage at Pin CANL	0 < V _{CC} < 5.25 V; No Time Limit	-58	+58	V
V _{SPLIT}	DC Voltage at Pin V _{SPLIT}	0 < V _{CC} < 5.25 V; No time Limit	-58	+58	V
V _{O(dif)(bus_dom)}	Differential Bus Output Voltage in Dominant State	42.5 Ω < R _{LT} < 60 Ω	1.5	3	V
CM _{range}	Input Common-Mode Range for Comparator	Guaranteed Differential Receiver Threshold and Leakage Current	-35	+35	V
C _{load}	Load Capacitance on IC Outputs			15	pF
t _{pd(rec-dom)}	Propagation Delay TxD to RxD	See Figure 6	90	230	ns
t _{pd(dom-rec)}	Propagation Delay TxD to RxD	See Figure 6	90	245	ns
T _J	Junction Temperature		-40	150	°C
ESD _{HBM}	ESD Level, Human Body Model	Pins CANH, CANL, V _{SPLIT} , WAKE, V _{BAT} other Pins	-4 -3	4 3	kV

NCV7341

BLOCK DIAGRAM

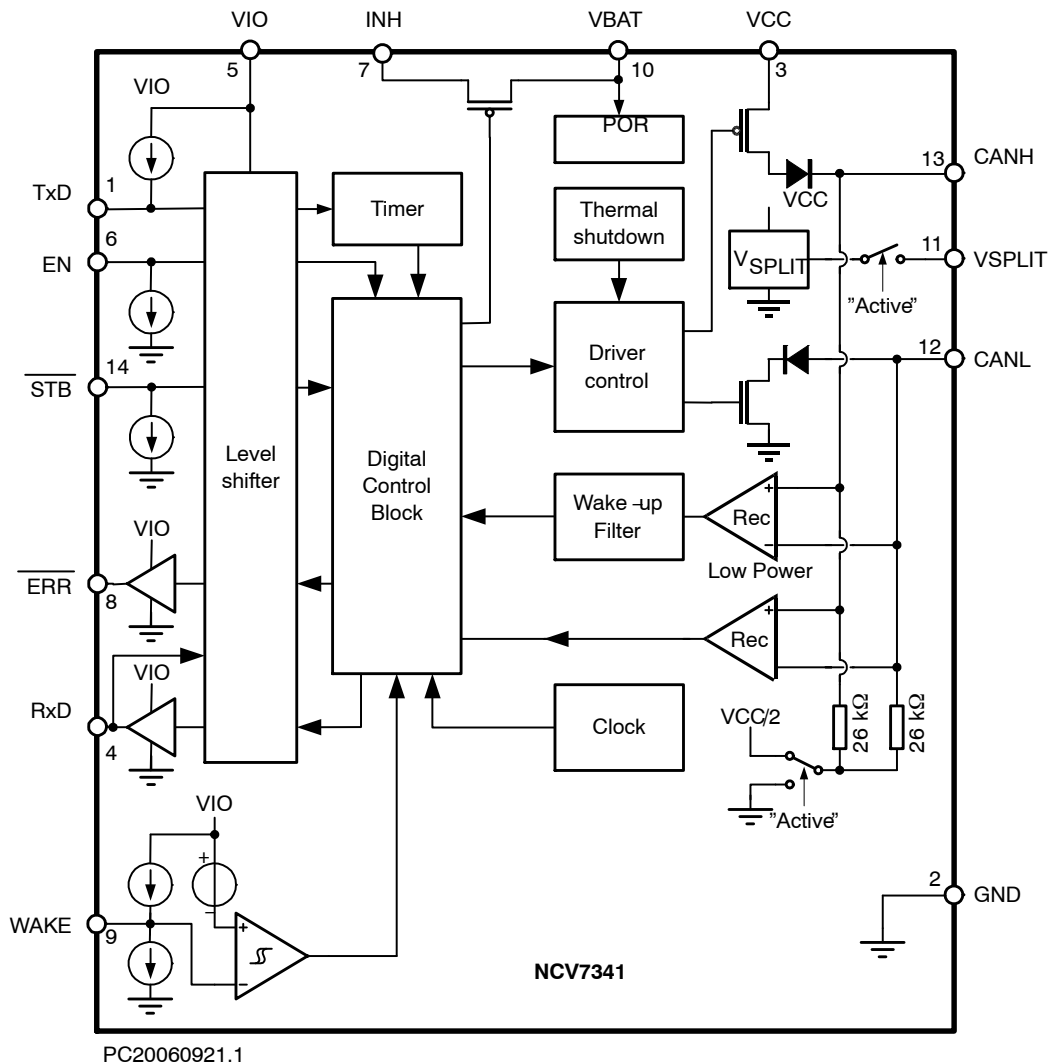
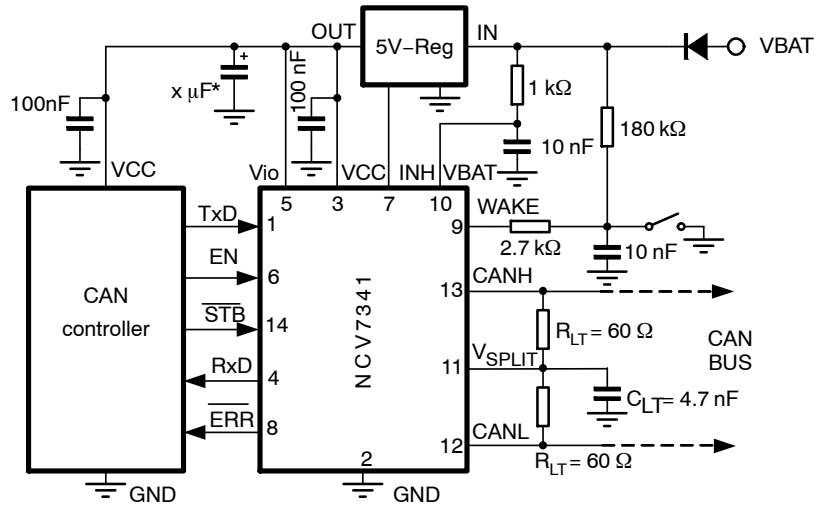

Figure 1. Block Diagram

NCV7341

TYPICAL APPLICATION SCHEMATICS



Note (*): Value depending on regulator

PC20060921.4

Figure 2. Application Diagram with a 5V CAN Controller

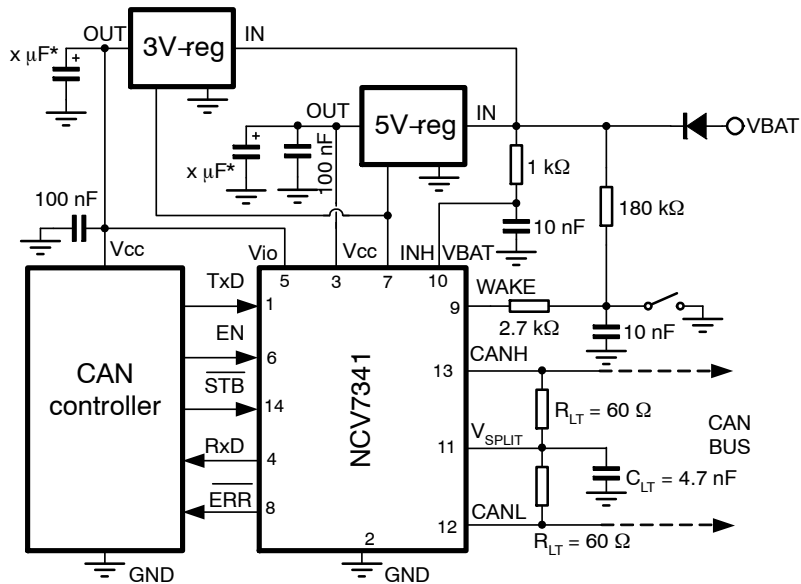

Note (*): Value depending on regulator

PC20060921.4

Figure 3. Application Diagram with a 3V CAN Controller

NCV7341

PIN DESCRIPTION

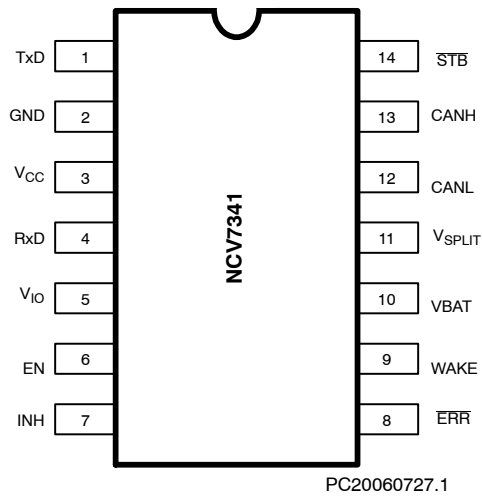

Figure 4. NCV7340 Pin Assignment

Table 2. PIN DESCRIPTION

Pin	Name	Description
1	TxD	Transmit data input; low level = dominant on the bus; internal pull-up current
2	GND	Ground
3	V _{CC}	Supply voltage for the core circuitry and the transceiver
4	RxD	Receive data output; dominant bus => low output
5	V _{IO}	Supply voltage for the CAN controller interface
6	EN	Enable input; internal pull-down current
7	INH	High voltage output for controlling external voltage regulators
8	ERR	Digital output indicating errors and power-up; active low
9	WAKE	Local wake-up input
10	V _{BAT}	Battery supply connection
11	V _{SPLIT}	Common-mode stabilization output
12	CANL	Low-level CAN bus line (low in dominant)
13	CANH	High-level CAN bus line (high in dominant)
14	STB	Stand-by mode control input; internal pull-down current

FUNCTIONAL DESCRIPTION

OPERATING MODES

Operation modes of NCV7341 are shown in Figures 5 and in Table 3.

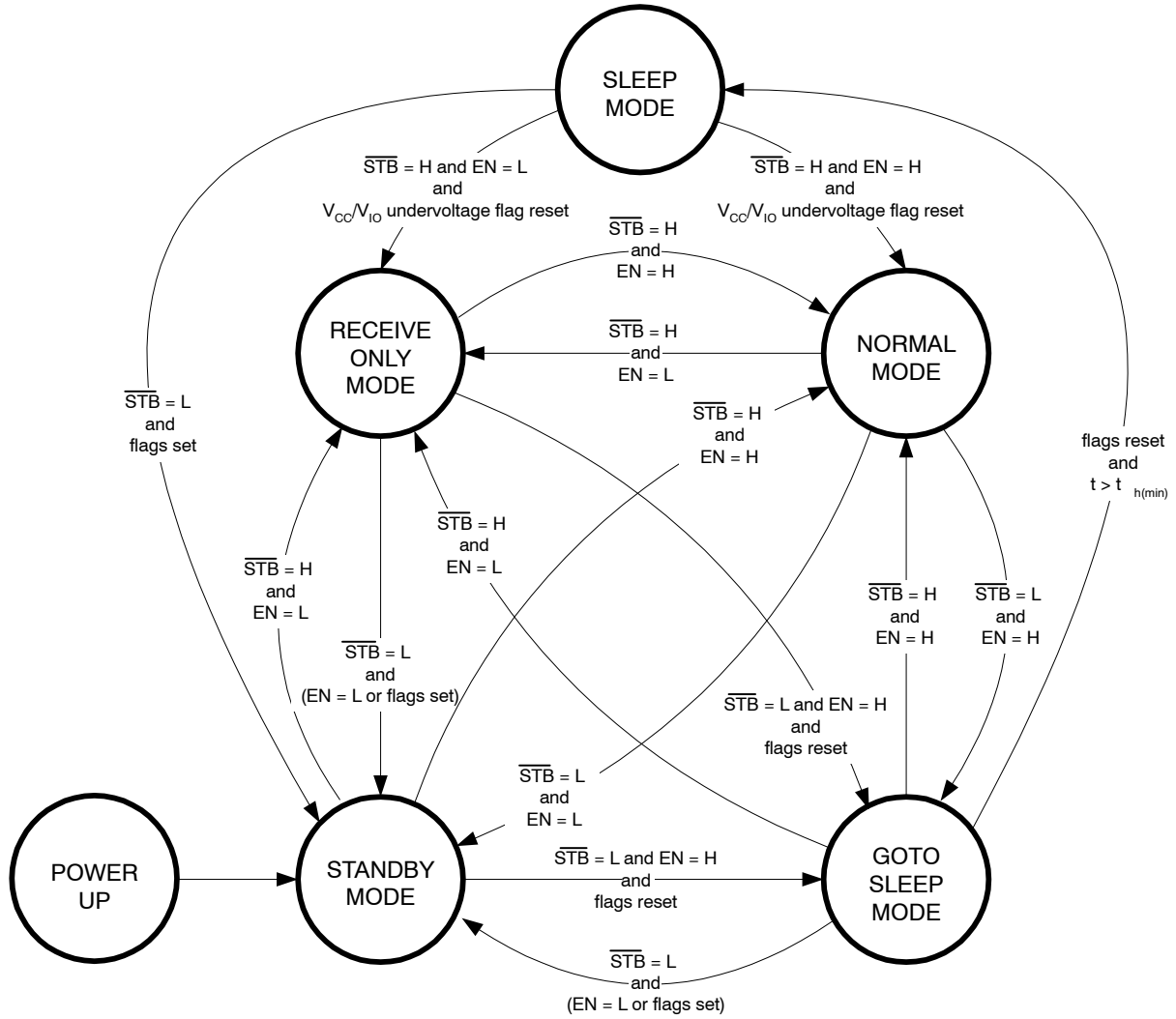

LEGEND

"Flags set" : wake-up or power-up
 "Flags reset" : not (wake-up or power-up)

PC20060921.2

Figure 5. Operation Modes

Table 3. OPERATION MODES

Conditions					Transceiver Behavior	
Pin STB	Pin EN	V _{CC} /V _{IO} Undervoltage Flag	V _{BAT} Undervoltage Flag	Power-up or Wakeup Flag	Operating Mode	Pin INH
X	X	Set	X	X	Sleep	Floating
		Reset	Set	Set	Standby	High
				Reset	If in sleep, then no change	Floating
					otherwise stand-by	High
Low	Low	Reset	Reset	Set	Stand-by	High
				Reset	If in sleep, then no change	Floating
					otherwise stand-by	High
Low	High	Reset	Reset	Set	Stand-by	High
				Reset	If in sleep, then no change	Floating
					otherwise go-to-sleep	High
High	Low	Reset	Reset	X	Receive-only	High
High	High	Reset	Reset	X	Normal	High

Normal Mode

In Normal mode, the transceiver is able to communicate via the bus lines. The CAN controller can transmit data to the bus via TxD pin and receive data from the bus via Pin RxD. The bus lines (CANH and CANL) are internally biased to V_{CC}/2 via the common-mode input resistance. Pin V_{SPLIT} is also providing voltage V_{CC}/2 which can be further used to externally stabilize the common mode voltage of the bus – see Figure 2 and Figure 3. Pin INH is active (pulled high) so that the external regulators controlled by INH Pin are switched on.

Receive-Only Mode

In Receive-only mode, the CAN transmitter is disabled. The CAN controller can still receive data from the bus via RxD Pin as the receiver part remains active. Equally to normal mode, the bus lines (CANH and CANL) are internally biased to V_{CC}/2 and Pin V_{SPLIT} is providing voltage V_{CC}/2. Pin INH is also active (pulled high).

Standby Mode

Standby mode is a low-power mode. Both the transmitter and the receiver are disabled and a very low-power differential receiver monitors the CAN bus activity. Bus lines are biased internally to ground via the common mode input resistance and Pin V_{SPLIT} is high-impedant (floating). A wake-up event can be detected either on the CAN bus or on the WAKE Pin. A valid wake-up is signaled on pins ERR and RxD. Pin INH remains active (pulled high) so that the external regulators controlled by INH Pin are switched on.

Go-To-Sleep Mode

Go-To-Sleep mode is an intermediate state used to put the transceiver into sleep mode in a controlled way. Go-To-Sleep mode is entered when the CAN controller

puts pin EN to High and $\overline{\text{STB}}$ Pin to Low. If the logical state of Pins EN and $\overline{\text{STB}}$ is kept unchanged for minimum period of t_{h(min)} and neither a wake-up nor a power-up event occur during this time, the transceiver enters sleep mode. While in go-to-sleep mode, the transceiver behaves identically to stand-by mode.

Sleep Mode

Sleep mode is a low-power mode in which the consumption is further reduced compared to stand-by mode. Sleep mode can be entered via go-to-sleep mode or in case an undervoltage on either V_{CC} or V_{IO} occurs for longer than the under-voltage detection time. The transceiver behaves identically to standby mode, but the INH Pin is deactivated (left floating) and the external regulators controlled by INH Pin are switched off. In this way, the V_{BAT} consumption is reduced to a minimum. The device will leave sleep mode either by a wake-up event (in case of a CAN bus wake-up or via Pin WAKE) or by putting Pin $\overline{\text{STB}}$ high (as long as an under-voltage on V_{CC} or V_{IO} is not detected).

Internal Flags

The transceiver keeps several internal flags reflecting conditions and events encountered during its operation. Some flags influence the operation mode of the transceiver (see Figure 5 and Table 3). Beside the undervoltage and the TxD dominant timeout flags, all others can be read by the CAN controller on Pin ERR. Pin ERR signals internal flags depending on the operation mode of the transceiver. An overview of the flags and their visibility on Pin ERR is given in Table 4. Because the ERR Pin uses negative logic, it will be pulled low if the signaled flag is set and will be pulled high if the signaled flag is reset.

Table 4. INTERNAL FLAGS AND THEIR VISIBILITY

Internal Flag	Set Condition	Reset Condition	Visibility on Pin ERR
V _{CC} /V _{IO} Undervoltage	V _{CC} < V _{CC(SLEEP)} longer than t _{UV(VCC)} or V _{IO} < V _{IO(SLEEP)} longer than t _{UV(VIO)}	At wake-up or power-up	No
V _{BAT} Undervoltage	V _{BAT} < V _{BAT(STB)}	When V _{BAT} recovers	No
Powerup	V _{BAT} rises above V _{BAT(PWUP)} (V _{BAT} connection to the transceiver)	When normal mode is entered	In receive-only mode. Not going from normal mode
Wake-up	When remote or local wake-up is detected	At power-up or when normal mode is entered or when V _{CC} /V _{IO} undervoltage flag is set	Both on ERR and RxD (both pulled to low). In go-to-sleep, standby and sleep mode.
Local Wake-up	When local wake-up is detected (i.e. via pin WAKE)	At power-up or when leaving normal mode	In normal mode before 4 consecutive dominant symbols are sent. Then ERR pin becomes High again
Failure	Pin TxD clamped low or overtemperature	When entering normal mode or when RxD is Low while TxD is high (provided all failures disappeared)	Overtemperature condition observable in receive-only mode entered from normal mode
Bus Failure (NCV7341D20)	One of the bus lines shorted to ground or supply during four consecutive transmitted dominants	No bus line short (to ground or supply) detected during four consecutive dominant bit transmissions	In normal mode

V_{CC}/V_{IO} Undervoltage Flag

The V_{CC}/V_{IO} undervoltage flag is set if V_{CC} supply drops below V_{CC(sleep)} level for longer than t_{UV(VCC)} or V_{IO} supply drops below V_{IO(sleep)} level for longer than t_{UV(VIO)}. If the flag is set, the transceiver enters sleep mode. After a waiting time identical to the undervoltage detection times t_{UV(VCC)} and t_{UV(VIO)}, respectively, the flag can be reset either by a valid wake-up request or when the powerup flag is set. During this waiting time, the wakeup detection is blocked.

V_{BAT} Under-voltage Flag

The flag is set when V_{BAT} supply drops below V_{BAT(STB)} level. The transceiver will enter the standby mode. The flag is reset when V_{BAT} supply recovers. The transceiver then enters the mode defined by inputs STB and EN.

Power-up Flag

This flag is set when V_{BAT} supply recovers after being below V_{BAT(PWUP)} level, which corresponds to a connection of the transceiver to the battery. The V_{CC}/V_{IO} undervoltage flag is cleared so that the transceiver cannot enter the Go-to-sleep Mode, ensuring that INH Pin is high and the external voltage regulators are activated at the battery connection. In Receive-only mode, the powerup flag can be observed on the ERR Pin. The flag is reset when Normal mode is entered.

Wake-up Flag

This flag is set when the transceiver detects a valid wake-up request via the bus or via the WAKE Pin. Setting the wake-up flag is blocked during the waiting time of the V_{CC}/V_{IO} undervoltage flag. The wake-up flag is immediately propagated to Pins ERR and RxD – provided that supplies V_{CC} and V_{IO} are available. The wake-up flag

is reset at power-up or when V_{CC}/V_{IO} undervoltage occurs or when Normal mode is entered.

Local wake-up Flag

This flag is set when a valid wake-up request through WAKE Pin occurs. It can be observed on the ERR Pin in normal mode. It can only be set when the powerup flag is reset. The local wake-up flag is reset at powerup or at leaving Normal mode.

Failure Flag

The failure flag is set in one of the following situations:

- TxD Pin is Low (i.e. dominant is requested by the CAN controller) for longer than t_{dom(TxD)} – Under this condition, the transmitter is disabled so that a bus lockup is avoided in case of an application failure which would drive permanent dominant on the bus. The transmitter remains disabled until the failure flag is reset.
- Overtemperature – If the junction temperature reaches T_{J(SD)}, the transmitter is disabled in order to protect it from overheating and the failure flag is set. The transmitter remains disabled until the failure flag is reset.

The failure flag is reset when Normal mode is entered or when TxD pin is High while RxD pin is Low. In case of overtemperature, the failure flag is observable on pin ERR.

Bus Failure Flag (NCV7341D20)

The transmitter of the NCV7341D20 device version allows bus failure detection. During dominant bit transmission, a short of the CANH or CANL line to ground or supply (V_{CC}, V_{BAT} or other) is internally detected. If the short circuit condition lasts for four consecutive dominant

transmissions, an internal bus failure flag is set and made immediately visible through a Low level on the ERR pin. The transmission and reception circuitry continues to function.

When four consecutive dominant transmissions succeed without a bus line short being detected, the internal bus failure flag is reset and $\overline{\text{ERR}}$ pin is released to High level.

Split Circuit

The V_{SPLIT} Pin is operational only in normal and receive-only modes. It is floating in standby and sleep modes. The V_{SPLIT} can be connected as shown in Figure 2 and Figure 3 and its purpose is to provide a stabilized DC voltage of $V_{\text{CC}}/2$ to the bus avoiding possible steps in the common-mode signal, therefore reducing EME. These unwanted steps could be caused by an unpowered node on the network with excessive leakage current from the bus that shifts the recessive voltage from its nominal $V_{\text{CC}}/2$ level.

Wake-up

The transceiver can detect wake-up events in stand-by, go-to-sleep and sleep modes. Two types of wake-up events are handled – remote wake-up via the CAN bus or a local wake-up via the WAKE pin. A valid remote wake-up is recognized after two dominant states of the CAN bus of at least t_{dom} , each of them followed by a recessive state of at least t_{rec} .

A local wake-up is detected after a change of state (High to Low, or Low to High) on WAKE Pin which is stable for at least t_{WAKE} . To increase the EMS level of the WAKE Pin, an internal current source is connected to it. If the state of the WAKE Pin is stable at least for t_{WAKE} , the direction of the current source follows (pulldown current for Low state, pullup current for High state). It is recommended to connect Pin WAKE either to GND or VBAT if it's not used in the application.

Fail Safe Features

Fail safe behavior is ensured by the detection functions associated with the internal flags.

Furthermore, a current-limiting circuit protects the transmitter output stage from damage caused by accidental short circuit to either positive or negative supply voltage, although power dissipation increases during this fault condition.

The Pins CANH and CANL are protected from automotive electrical transients (according to ISO 7637; see Figure 9). Pins TxD is pulled high and Pins $\overline{\text{STB}}$ and EN are pulled low internally should the input become disconnected. Pins TxD, $\overline{\text{STB}}$, EN and RxD will be floating, preventing reverse supply should the V_{IO} supply be removed.

ELECTRICAL CHARACTERISTICS

Definitions

All voltages are referenced to GND (Pin 2). Positive currents flow into the IC. Sinking current means the current is flowing into the pin; sourcing current means the current is flowing out of the pin.

Absolute Maximum Ratings

Stresses above those listed in the following table may cause permanent device failure. Exposure to absolute maximum ratings for extended periods may affect device reliability.

Table 5. ABSOLUTE MAXIMUM RATINGS

Symbol	Parameter	Conditions	Min.	Max.	Unit
V_{BAT}	Supply voltage		-0.3	58	V
V_{CC}	Supply voltage		-0.3	+7	V
V_{IO}	Supply voltage		-0.3	+7	V
V_{CANH}	DC voltage at pin CANH	$0 < V_{CC} < 5.25$ V; no time limit	-58	+58	V
V_{CANL}	DC voltage at pin CANL	$0 < V_{CC} < 5.25$ V; no time limit	-58	+58	V
$V_{CANL}-V_{CANH}$	DC voltage between bus pins CANH and CANL	$0 < V_{CC} < 5.25$ V; no time limit	-58	+58	V
V_{SPLIT}	DC voltage at pin VSPLIT	$0 < V_{CC} < 5.25$ V; no time limit	-58	+58	V
V_{INH}	DC voltage at pin INH		-0.3	$V_{BAT}+0.3$	V
V_{WAKE}	DC voltage at pin WAKE		-0.3	58	V
V_{TxD}	DC voltage at pin TxD		-0.3	7	V
V_{RxD}	DC voltage at pin RxD		-0.3	$V_{IO} + 0.3$	V
$\overline{V_{STB}}$	DC voltage at pin STB		-0.3	7	V
V_{EN}	DC voltage at pin EN		-0.3	7	V
$\overline{V_{ERR}}$	DC voltage at pin ERR		-0.3	$V_{IO} + 0.3$	V
$V_{tran}(CANH)$	Transient voltage at pin CANH	(Note 1)	-300	+300	V
$V_{tran}(CANL)$	Transient voltage at pin CANL	(Note 1)	-300	+300	V
$V_{tran}(VSPLIT)$	Transient voltage at pin VSPLIT	(Note 1)	-300	+300	V
$V_{esd}(CANL/CANH/VSPLIT, VBAT, WAKE)$	Electrostatic discharge voltage at pins intended to be wired outside of the module (CANH, CANL, V_{SPLIT} , VBAT, WAKE)	(Note 2) (Note 4)	-4 -500	4 500	kV V
V_{esd}	Electrostatic discharge voltage at all other pins	(Note 2) (Note 4)	-3 -500	3 500	kV V
Latch-up	Static latch-up at all pins	(Note 3)		120	mA
T_{stg}	Storage temperature		-50	+150	°C
T_{amb}	Ambient temperature		-50	+125	°C
T_{junc}	Maximum junction temperature		-50	+180	°C

Stresses exceeding Maximum Ratings may damage the device. Maximum Ratings are stress ratings only. Functional operation above the Recommended Operating Conditions is not implied. Extended exposure to stresses above the Recommended Operating Conditions may affect device reliability.

1. Applied transient waveforms in accordance with ISO 7637 part 3, test pulses 1, 2, 3a, and 3b (see Figure 9).
2. Standardized human body model electrostatic discharge (ESD) pulses in accordance to MIL883 method 3015.7.
3. Static latch-up immunity: Static latch-up protection level when tested according to EIA/JESD78.
4. Standardized charged device model ESD pulses when tested according to EOS/ESD DS5.3-1993.

NCV7341

Operating Conditions

Operating conditions define the limits for functional operation, parametric characteristics and reliability specification of the device. Functionality of the device is not guaranteed outside the operating conditions.

Table 6. OPERATING RANGES

Symbol	Parameter	Conditions	Min	Max	Unit
V _{BAT}	Supply Voltage		5.0	50	V
V _{BAT_SLEEP}	Supply Voltage in the Sleep Mode	(Note 1)	6.0	50	V
V _{CC}	Supply Voltage		4.75	5.25	V
V _{IO}	Supply Voltage		2.8	5.25	V
V _{CANH}	DC Voltage at Pin CANH	Receiver Function Guaranteed	-35	+35	V
V _{CANL}	DC Voltage at Pin CANL	Receiver Function Guaranteed	-35	+35	V
V _{CANL-V_{CANH}}	DC Voltage Between Bus Pins CANH and CANL	Receiver Function Guaranteed	-35	+35	V
V _{SPLIT}	DC Voltage at Pin V _{SPLIT}	Leakage and Current Limitation are Guaranteed	-35	+35	V
V _{INH}	DC Voltage at Pin INH		-0.3	V _{BAT} + 0.3	V
V _{WAKE}	DC Voltage at Pin WAKE		-0.3	V _{BAT} + 0.3	V
V _{TxD}	DC Voltage at Pin TxD		-0.3	V _{IO} + 0.3	V
V _{RxD}	DC Voltage at Pin RxD		-0.3	V _{IO} + 0.3	V
V _{STB}	DC Voltage at Pin STB		-0.3	V _{IO} + 0.3	V
V _{EN}	DC Voltage at Pin EN		-0.3	V _{IO} + 0.3	V
V _{ERR}	DC Voltage at Pin ERR		-0.3	V _{IO} + 0.3	V
C _{LOAD}	Capacitive Load on Digital Outputs (Pins RxD and ERR)			15	pF
T _A	Ambient Temperature		-40	+125	°C
T _J	Maximum Junction Temperature		-40	+150	°C

1. In the sleep mode, all relevant parameters are guaranteed only for V_{BAT} > 6 V. For V_{BAT} between 5 V and 6 V, no power-on-reset will occur and the functionality is also guaranteed, but some parameters might get slightly out of the specification – e.g. the wakeup detection thresholds.

Table 7. THERMAL CHARACTERISTICS

Symbol	Parameter	Conditions	Value	Unit
R _{th(vj-a)}	Thermal Resistance from Junction-to-Ambient in SOIC-14 Package	1S0P PCB	128	K/W
R _{th(vj-a)}	Thermal Resistance from Junction-to-Ambient in SOIC-14 Package	2S2P PCB	70	K/W

Characteristics

The characteristics of the device are valid for operating conditions defined in Table 7 and the bus lines are considered to be loaded with $R_{LT} = 60 \Omega$, unless specified otherwise.

Table 8. DC CHARACTERISTICS

Symbol	Parameter	Conditions	Min	Typ	Max	Unit
SUPPLY (PIN VBAT)						
$V_{BAT(STB)}$	Level for Setting V_{BAT} Undervoltage Flag	$V_{CC} = 5 V$	2.75	3.3	4.5	V
$V_{BAT(PWUP)}$	Level for Setting Powerup Flag	$V_{CC} = 0 V$	2.75	3.3	4.5	V
I_{VBAT}	V_{BAT} Current Consumption in Normal and Receive-Only Modes	INH and WAKE Not Loaded	1.0	10	40	μA
	V_{BAT} Current Consumption in Standby and Go-to-Sleep Modes. The total supply current is drawn partially from V_{BAT} and partially from V_{CC} .	$V_{VCC} > 4.75 V, V_{VIO} > 2.8 V$ $V_{INH} = V_{WAKE} = V_{VBAT} = 12 V$ $T_{amb} < 100^\circ C$			18	μA
		$V_{VCC} > 4.75 V, V_{VIO} > 2.8 V$ $V_{INH} = V_{WAKE} = V_{VBAT} = 12 V$	8.0	12	22.5	μA
	V_{BAT} Current Consumption in Sleep Mode. The supply current is drawn from V_{BAT} only.	$V_{VCC} = V_{INH} = V_{VIO} = 0 V$ $V_{WAKE} = V_{VBAT} = 12 V$ $T_{amb} < 100^\circ C$			35	μA
$V_{VCC} = V_{INH} = V_{VIO} = 0 V$ $V_{WAKE} = V_{VBAT} = 12 V$		10	20	50	μA	
SUPPLY (PIN VCC)						
$V_{CC(SLEEP)}$	V_{CC} Level for Setting V_{CC}/V_{IO} Undervoltage Flag	$V_{BAT} = 12 V$	2.75	3.3	4.5	V
I_{VCC}	V_{CC} Current Consumption in Normal or Receive-Only Mode	Normal Mode: $V_{TXD} = 0 V$, i.e. Dominant	25	55	80	mA
		Normal Mode: $V_{TXD} = V_{IO}$, i.e. Recessive (or Receive-Only Mode)	2.0	6.0	10	mA
	V_{CC} Current Consumption in Standby and Go-to-Sleep Mode. The total supply current is drawn partially from V_{BAT} and partially from V_{CC} .	$T_{amb} < 100^\circ C$			17.5	μA
			6.5	12	19.5	μA
	V_{CC} Current Consumption in Sleep Mode	$T_{amb} < 100^\circ C$			1.0	μA
		0.2	0.5	2.0	μA	
SUPPLY (PIN VIO)						
$V_{IO(SLEEP)}$	V_{IO} Level for Setting V_{CC}/V_{IO} Undervoltage Flag		0.9	1.6	2.0	V
I_{VIO}	V_{IO} Current Consumption in Normal or Receive-Only Mode	Normal Mode: $V_{TXD} = 0V$, i.e. Dominant	100	350	1000	μA
		Normal Mode: $V_{TXD} = V_{IO}$, i.e. Recessive (or Receive-Only mode)	0	0.2	1.0	μA
	V_{IO} Current Consumption in Standby or Sleep Mode	$T_{amb} < 100^\circ C$			1.0	μA
		0	0	5.0	μA	
TRANSMITTER DATA INPUT (PIN TXD)						
V_{IH}	High-Level Input Voltage	Output Recessive	$0.7V_{VIO}$	-	$V_{IO} + 0.3$	V
V_{IL}	Low-Level Input Voltage	Output Dominant	-0.3	-	$0.3V_{VIO}$	V
I_{IH}	High-Level Input Current	$V_{TXD} = V_{VIO}$	-5.0	0	+5.0	μA

Table 8. DC CHARACTERISTICS

Symbol	Parameter	Conditions	Min	Typ	Max	Unit
TRANSMITTER DATA INPUT (PIN TxD)						
I_{IL}	Low-Level Input Current	$V_{TxD} = 0.3 V_{VIO}$	-70	-250	-500	μA
C_i	Input Capacitance	Not Tested	1.0	5.0	10	μF
STANDBY AND ENABLE INPUTS (PINS STB AND EN)						
V_{IH}	High-Level Input Voltage		$0.7V_{VIO}$	-	$V_{IO} + 0.3$	V
V_{IL}	Low-Level Input Voltage		-0.3	-	$0.3V_{VIO}$	V
I_{IH}	High-Level Input Current	$V_{STB} = V_{EN} = 0.7V_{VIO}$	1.0	5.0	10	μA
I_{IL}	Low-Level Input Current	$V_{STB} = V_{EN} = 0 V$	-0.5	0	5.0	μA
C_i	Input Capacitance		1.0	5.0	10	μF
RECEIVER DATA OUTPUT (PIN RxD)						
I_{OH}	High-Level Output Current	$V_{RxD} = V_{VIO} - 0.4 V$ $V_{VIO} = V_{VCC}$	-1.0	-3.0	-6.0	mA
I_{OL}	Low-Level Output Current	$V_{RxD} = 0.4 V$ $V_{TxD} = 0 V$ Bus is Dominant	2.0	5.0	12	mA
FLAG INDICATION OUTPUT (PIN ERR)						
I_{OH}	High-Level Output Current	$V_{ERR} = V_{VIO} - 0.4 V$ $V_{VIO} = V_{VCC}$	-4.0	-20	-50	μA
I_{OL}	Low-Level Output Current	$V_{ERR} = 0.4 V$	100	200	350	μA
LOCAL WAKE-UP INPUT (PIN WAKE)						
I_{IH}	High-Level Input Current	$V_{WAKE} = V_{VBAT} - 1.9 V$	-1.0	-5.0	-10	μA
I_{IL}	Low-Level Input Current	$V_{WAKE} = V_{VBAT} - 3.1 V$	1.0	5.0	10	μA
$V_{threshold}$	Threshold of the Local Wake-up Comparator	Sleep or Standby Mode	$V_{VBAT} - 3 V$	$V_{VBAT} - 2.5 V$	$V_{VBAT} - 2 V$	V
INHIBIT OUTPUT (PIN INH)						
V_{HDROP}	High Level Voltage Drop	$I_{INH} = -180 \mu A$	50	200	800	mV
I_{LEAK}	Leakage Current in Sleep Mode		0	-	5.0	μA
		$T_{amb} < 100^\circ C$	0	-	1.0	μA
BUS LINES (PINS CANH AND CANL)						
$V_{o(reces)} (norm)$	Recessive Bus Voltage	$V_{TxD} = V_{VCC}$; No Load, Normal Mode	2.0	2.5	3.0	V
$V_{o(reces)} (stby)$	Recessive Bus Voltage	$V_{TxD} = V_{VCC}$; No Load, Standby Mode	-100	0	100	mV
$I_{o(reces)} (CANH)$	Recessive Output Current at Pin CANH	$-35 V < V_{CANH} < +35 V$; $0 V < V_{CC} < 5.25 V$	-2.5	-	+2.5	mA
$I_{o(reces)} (CANL)$	Recessive Output Current at Pin CANL	$-35 V < V_{CANL} < +35 V$; $0 V < V_{VCC} < 5.25 V$	-2.5	-	+2.5	mA
$V_{o(dom)} (CANH)$	Dominant output Voltage at Pin CANH	$V_{TxD} = 0 V$	3.0	3.6	4.25	V
$V_{o(dom)} (CANL)$	Dominant Output Voltage at Pin CANL	$V_{TxD} = 0 V$	0.5	1.4	1.75	V
$V_{o(dif)} (bus_dom)$	Differential Bus Output Voltage ($V_{CANH} - V_{CANL}$)	$V_{TxD} = 0 V$; Dominant; $42.5 \Omega < R_{LT} < 60 \Omega$	1.5	2.25	3.0	V
$V_{o(dif)} (bus_rec)$	Differential Bus Output Voltage ($V_{CANH} - V_{CANL}$)	$V_{TxD} = V_{CC}$; Recessive; No Load	-120	0	+50	mV
$I_{o(sc)} (CANH)$	Short-Circuit Output Current at Pin CANH	$V_{CANH} = 0 V$; $V_{TxD} = 0 V$	-45	-70	-120	mA

NCV7341

Table 8. DC CHARACTERISTICS

Symbol	Parameter	Conditions	Min	Typ	Max	Unit
BUS LINES (PINS CANH AND CANL)						
$I_{o(sc)}$ (CANL)	Short-Circuit Output Current at Pin CANL	$V_{CANL} = 42\text{ V}; V_{TXD} = 0\text{ V}$	45	70	120	mA
$V_{i(dif)}$ (th)	Differential Receiver Threshold Voltage (see Figure 7)	$-12\text{ V} < V_{CANL} < +12\text{ V}$ $-12\text{ V} < V_{CANH} < +12\text{ V}$	0.5	0.7	0.9	V
$V_{ihcm(dif)}$ (th)	Differential Receiver Threshold Voltage for High Common-Mode (see Figure 7)	$-35\text{ V} < V_{CANL} < +35\text{ V}$ $-35\text{ V} < V_{CANH} < +35\text{ V}$	0.35	0.7	1.00	V
$V_{i(dif)}$ (hys)	Differential Receiver Input Voltage Hysteresis (see Figure 7)	$-35\text{ V} < V_{CANL} < +35\text{ V}$ $-35\text{ V} < V_{CANH} < +35\text{ V}$	50	70	100	mV
$V_{I(dif_WAKE)}$	Differential Receiver Input Voltage for Bus Wake-up Detection (in Sleep or Standby Mode)	$-12\text{ V} < V_{CANH} < +12\text{ V}$ $-12\text{ V} < V_{CANL} < +12\text{ V}$	0.4	0.8	1.15	V
$R_{i(cm)}$ (CANH)	Common-Mode Input Resistance at Pin CANH		15	26	39	k Ω
$R_{i(cm)}$ (CANL)	Common-Mode Input Resistance at Pin CANL		15	26	39	k Ω
$R_{i(cm)(m)}$	Matching between Pin CANH and Pin CANL Common Mode Input Resistance	$V_{CANH} = V_{CANL}$	-3.0	0	+3.0	%
$R_{i(dif)}$	Differential Input Resistance		25	50	75	k Ω
$C_{i(CANH)}$	Input Capacitance at Pin CANH	$V_{TXD} = V_{CC}$		7.5	20	pF
$C_{i(CANL)}$	Input Capacitance at Pin CANL	$V_{TXD} = V_{CC}$		7.5	20	pF
$C_{i(dif)}$	Differential Input Capacitance	$V_{TXD} = V_{CC}$		3.75	10	pF
COMMON-MODE STABILIZATION (PIN V_{SPLIT})						
V_{SPLIT}	Reference Output Voltage at Pin V_{SPLIT}	Normal mode; $-500\text{ }\mu\text{A} < I_{SPLIT} < 500\text{ }\mu\text{A}$	$0.3 \times V_{CC}$	$0.5 \times V_{CC}$	$0.7 \times V_{CC}$	
$I_{SPLIT(i)}$	V_{SPLIT} Leakage Current	Standby Mode $-27\text{ V} < V_{SPLIT} < 40\text{ V}$	-50		+50	μA
		Standby Mode $-27\text{ V} < V_{SPLIT} < 40\text{ V}$ $T_{amb} < 100^\circ\text{C}$	-5.0		+5.0	
$I_{SPLIT(lim)}$	V_{SPLIT} Limitation Current (Absolute Value)	Normal Mode	1.3	3.0	5.0	mA
THERMAL SHUTDOWN						
$T_{J(SD)}$	Shutdown Junction Temperature		150	160	180	$^\circ\text{C}$

Table 9. AC CHARACTERISTICS

Symbol	Parameter	Conditions	Min	Typ	Max	Unit
TIMING CHARACTERISTICS (Figure 6)						
$t_{d(TxD-BUSon)}$	Delay TxD to Bus Active	Setup According to Figure 8	40	85	105	ns
$t_{d(TxD-BUSoff)}$	Delay TxD to Bus Inactive	Setup According to Figure 8	30	60	105	ns
$t_{d(BUSon-RxD)}$	Delay Bus Active to RxD	Setup According to Figure 8	25	55	105	ns
$t_{d(BUSoff-RxD)}$	Delay Bus Inactive to RxD	Setup According to Figure 8	40	65	105	ns
$t_{pd(rec-dom)}$	Propagation Delay TxD to RxD from Recessive to Dominant	Setup According to Figure 8	90	130	230	ns
$t_{d(dom-rec)}$	Propagation Delay TxD to RxD from Dominant to Recessive	Setup According to Figure 8	90	140	245	ns
$t_{UV(VCC)}$	Undervoltage Detection Time on V_{CC}		5.0	10	12.5	ms
$t_{UV(VIO)}$	Undervoltage Detection Time on V_{IO}		5.0	10	12.5	ms
$t_{dom(TxD)}$	TxD Dominant Timeout		300	600	1000	μ s
$t_{h(min)}$	Minimum Hold-Time for the Go-to-Sleep Mode		15	35	50	μ s
t_{dom}	Dominant Time for Wake-up via the Bus	$V_{dif}(CAN) > 1.4 V$	0.75	2.5	5.0	μ s
		$V_{dif}(CAN) > 1.2 V$	0.75	3.0	5.8	μ s
t_{rec}	Recessive Time for Wake-up via the Bus	$V_{BAT} = 12 V$	0.75	2.5	5.0	μ s
t_{WAKE}	Debounce Time for the Wake-up via WAKE Pin	$V_{BAT} = 12 V$	5.0	25	50	μ s
t_{errdet}	Minimum dominant bit time for bus error detection	NCV7341D20 version	1	2	4	μ s

MEASUREMENT DEFINITIONS AND SETUPS

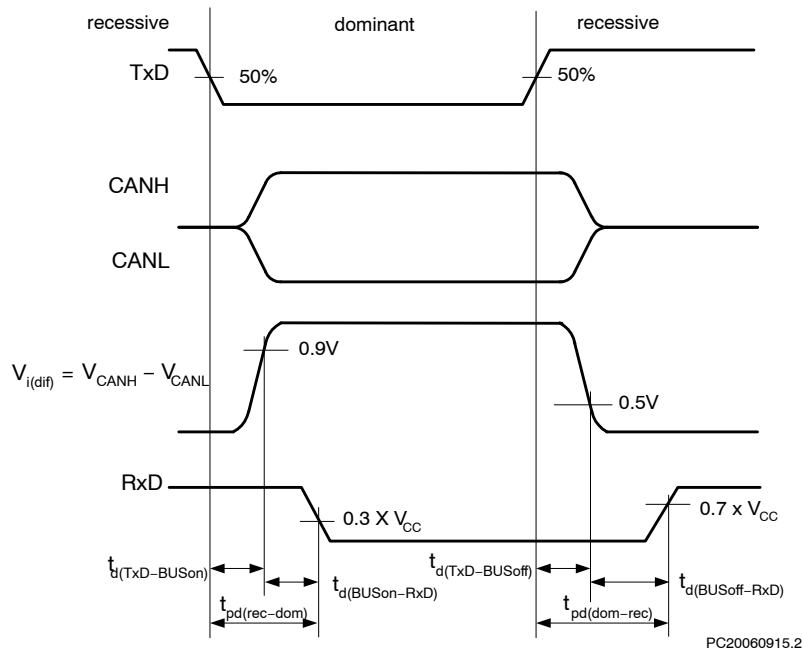

Figure 6. Timing Diagram for AC Characteristics

NCV7341

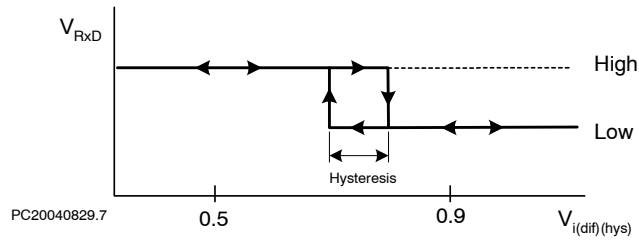

Figure 7. Hysteresis of the Receiver

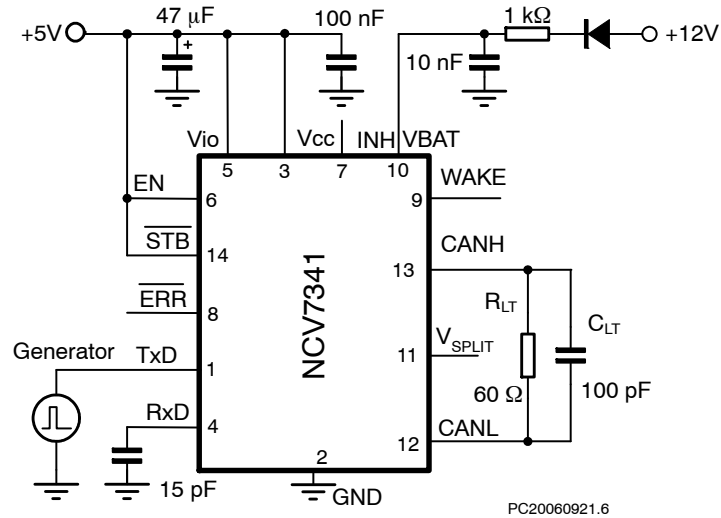

Figure 8. Test Circuit for Timing Characteristics

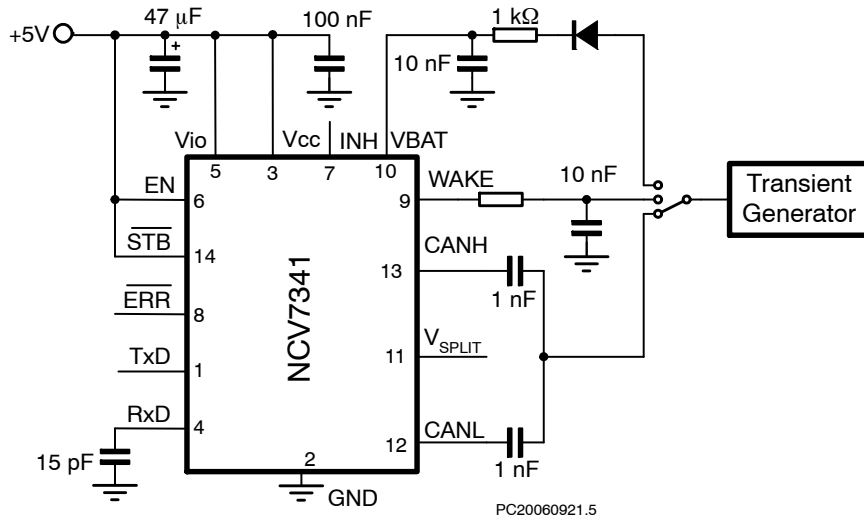

Figure 9. Test Circuit for Automotive Transients

NCV7341

DEVICE ORDERING INFORMATION

Part Number	Description	Temperature Range	Package Type	Shipping†
NCV7341D20G	HS CAN Transceiver with bus error detection	-40°C – 125°C	SOIC-14 (Pb-Free)	55 Tube / Tray
NCV7341D20R2G		-40°C – 125°C	SOIC-14 (Pb-Free)	3000 / Tape & Reel
NCV7341D21G	HS CAN Transceiver	-40°C – 125°C	SOIC-14 (Pb-Free)	55 Tube / Tray
NCV7341D21R2G		-40°C – 125°C	SOIC-14 (Pb-Free)	3000 / Tape & Reel

†For information on tape and reel specifications, including part orientation and tape sizes, please refer to our Tape and Reel Packaging Specifications Brochure, BRD8011/D.

MECHANICAL CASE OUTLINE PACKAGE DIMENSIONS

ON Semiconductor®

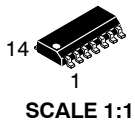

SOIC-14 CASE 751AP ISSUE B

DATE 18 MAY 2015

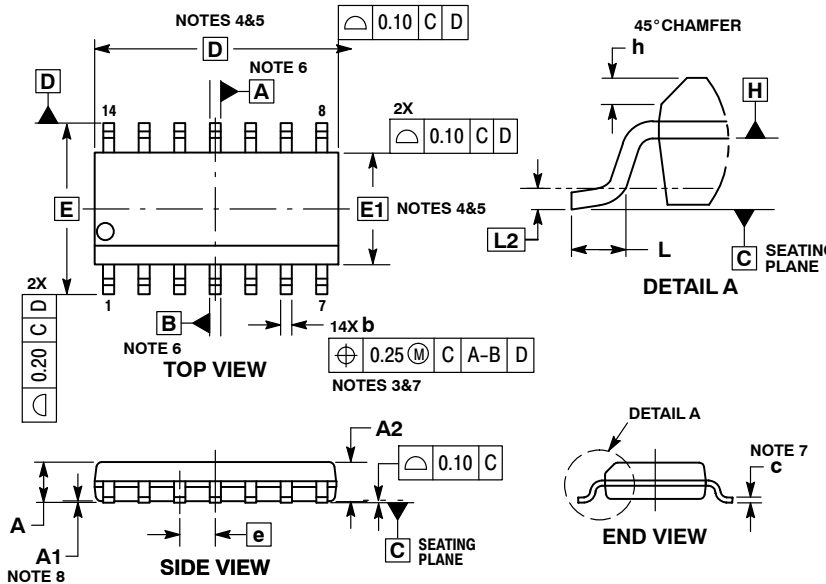

NOTES:

1. DIMENSIONING AND TOLERANCING PER ASME Y14.5M, 1994.
2. CONTROLLING DIMENSION: MILLIMETERS.
3. DIMENSION b DOES NOT INCLUDE DAMBAR PROTRUSION. ALLOWABLE PROTRUSION SHALL BE 0.004 mm IN EXCESS OF MAXIMUM MATERIAL CONDITION.
4. DIMENSION D DOES NOT INCLUDE MOLD FLASH, PROTRUSIONS OR GATE BURRS. MOLD FLASH, PROTRUSIONS OR GATE BURRS SHALL NOT EXCEED 0.006 mm PER SIDE. DIMENSION E1 DOES NOT INCLUDE INTERLEAD FLASH OR PROTRUSION. INTERLEAD FLASH OR PROTRUSION SHALL NOT EXCEED 0.010 mm PER SIDE.
5. THE PACKAGE TOP MAY BE SMALLER THAN THE PACKAGE BOTTOM. DIMENSIONS D AND E1 ARE DETERMINED AT THE OUTER-MOST EXTREMES OF THE PLASTIC BODY AT DATUM H.
6. DIMENSIONS A AND B ARE TO BE DETERMINED AT DATUM H.
7. DIMENSIONS b AND c APPLY TO THE FLAT SECTION OF THE LEAD BETWEEN 0.10 TO 0.25 FROM THE LEAD TIP.
8. A1 IS DEFINED AS THE VERTICAL DISTANCE FROM THE SEATING PLANE TO THE LOWEST POINT ON THE PACKAGE BODY.

DIM	MILLIMETERS	
	MIN	MAX
A	---	1.75
A1	0.10	0.25
A2	1.25	---
b	0.31	0.51
c	0.10	0.25
D	8.65 BSC	
E	6.00 BSC	
E1	3.90 BSC	
e	1.27 BSC	
h	0.25	0.41
L	0.40	1.27
L2	0.25 BSC	

RECOMMENDED SOLDERING FOOTPRINT*

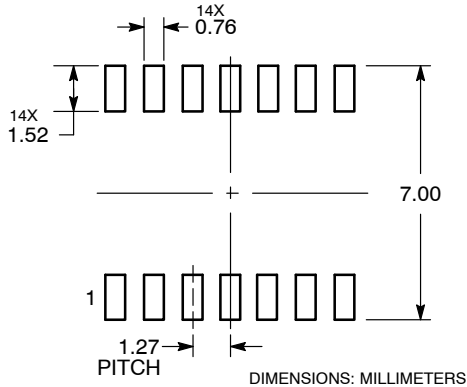

*For additional information on our Pb-Free strategy and soldering details, please download the ON Semiconductor Soldering and Mounting Techniques Reference Manual, SOLDERRM/D.

GENERIC MARKING DIAGRAM*

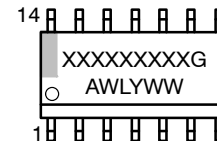

XXXXXX = Specific Device Code
 A = Assembly Location
 WL = Wafer Lot
 Y = Year
 WW = Work Week
 G = Pb-Free Package

*This information is generic. Please refer to device data sheet for actual part marking. Pb-Free indicator, "G" or microdot "▪", may or may not be present.

DOCUMENT NUMBER:	98AON30871E	Electronic versions are uncontrolled except when accessed directly from the Document Repository. Printed versions are uncontrolled except when stamped "CONTROLLED COPY" in red.
DESCRIPTION:	SOIC-14	PAGE 1 OF 1

ON Semiconductor and ON are trademarks of Semiconductor Components Industries, LLC dba ON Semiconductor or its subsidiaries in the United States and/or other countries. ON Semiconductor reserves the right to make changes without further notice to any products herein. ON Semiconductor makes no warranty, representation or guarantee regarding the suitability of its products for any particular purpose, nor does ON Semiconductor assume any liability arising out of the application or use of any product or circuit, and specifically disclaims any and all liability, including without limitation special, consequential or incidental damages. ON Semiconductor does not convey any license under its patent rights nor the rights of others.

onsemi, **Onsemi**, and other names, marks, and brands are registered and/or common law trademarks of Semiconductor Components Industries, LLC dba "**onsemi**" or its affiliates and/or subsidiaries in the United States and/or other countries. **onsemi** owns the rights to a number of patents, trademarks, copyrights, trade secrets, and other intellectual property. A listing of **onsemi**'s product/patent coverage may be accessed at www.onsemi.com/site/pdf/Patent-Marking.pdf. **onsemi** reserves the right to make changes at any time to any products or information herein, without notice. The information herein is provided "as-is" and **onsemi** makes no warranty, representation or guarantee regarding the accuracy of the information, product features, availability, functionality, or suitability of its products for any particular purpose, nor does **onsemi** assume any liability arising out of the application or use of any product or circuit, and specifically disclaims any and all liability, including without limitation special, consequential or incidental damages. Buyer is responsible for its products and applications using **onsemi** products, including compliance with all laws, regulations and safety requirements or standards, regardless of any support or applications information provided by **onsemi**. "Typical" parameters which may be provided in **onsemi** data sheets and/or specifications can and do vary in different applications and actual performance may vary over time. All operating parameters, including "Typicals" must be validated for each customer application by customer's technical experts. **onsemi** does not convey any license under any of its intellectual property rights nor the rights of others. **onsemi** products are not designed, intended, or authorized for use as a critical component in life support systems or any FDA Class 3 medical devices or medical devices with a same or similar classification in a foreign jurisdiction or any devices intended for implantation in the human body. Should Buyer purchase or use **onsemi** products for any such unintended or unauthorized application, Buyer shall indemnify and hold **onsemi** and its officers, employees, subsidiaries, affiliates, and distributors harmless against all claims, costs, damages, and expenses, and reasonable attorney fees arising out of, directly or indirectly, any claim of personal injury or death associated with such unintended or unauthorized use, even if such claim alleges that **onsemi** was negligent regarding the design or manufacture of the part. **onsemi** is an Equal Opportunity/Affirmative Action Employer. This literature is subject to all applicable copyright laws and is not for resale in any manner.

ADDITIONAL INFORMATION

TECHNICAL PUBLICATIONS:

Technical Library: www.onsemi.com/design/resources/technical-documentation
onsemi Website: www.onsemi.com

ONLINE SUPPORT: www.onsemi.com/support

For additional information, please contact your local Sales Representative at www.onsemi.com/support/sales