

Enhancement Mode Gallium Nitride (GaN) HEMT

700 V, 132 mΩ, 12 A, PTFP-N9 (DFN)

Preliminary Document NTMT170N70GN1

Features

- Low $R_{DS(ON)}$ to Minimize Conduction Losses
- Ultra Low Gate Charge for High Speed Switching
- $FOM-Q_G = 280 \text{ nC} \cdot \text{mW}$
- Small Footprint for High Density PCB Design
- This Device is Halide Free and RoHS Compliant with Exemption 7a, Pb-Free 2LI (on second level interconnection)

Typical Applications

- High Density Power Modules
- High Frequency AC-DC and DC-DC Converters
- High Performance PSU for Consumer and Industrial
- Resonant Conversion

MAXIMUM RATINGS ($T_J = 25^\circ\text{C}$ unless otherwise specified)

Parameter	Symbol	Value	Unit
Drain-to-Source Voltage	V_{DSS}	700	V
Drain-to-Source Transient Voltage, $t_p < 200 \mu\text{s}$	$V_{DS(TRAN)}$	800	V
Pulsed Drain-to-Source Voltage, $T_J = 25^\circ\text{C}$ ($t_{TOTAL} < 10 \text{ h}$) / $T_J = 125^\circ\text{C}$ ($t_{TOTAL} < 1 \text{ h}$)	$V_{DS(PULSE)}$	750	V
Gate-to-Source Voltage	V_{GS}	-6 to 7	V
Gate-to-Source Transient Voltage, $t_p = 50 \text{ ns}$, $f_p = 100 \text{ kHz}$, Open Drain	$V_{GS(PULSE)}$	-20 to 10	V
Continuous Drain Current, $T_{CASE} = 25^\circ\text{C}$	I_{DS}	12	A
Pulsed Drain Current, $t_p < 10 \mu\text{s}$, $T_C = 25^\circ\text{C}$ / $T_C = 125^\circ\text{C}$	$I_{DS(PULSE)}$	24 / 13	A
Power Dissipation, $V_{GS} = 6 \text{ V}$, $T_{CASE} = 25^\circ\text{C}$	P_{TOT}	69	W
Operating Junction Temperature	T_J	-55 to 150	$^\circ\text{C}$
Storage Temperature	T_{STG}	-55 to 150	$^\circ\text{C}$

Stresses exceeding those listed in the Maximum Ratings table may damage the device. If any of these limits are exceeded, device functionality should not be assumed, damage may occur and reliability may be affected.

THERMAL CHARACTERISTICS

Parameter	Symbol	Value	Unit
Junction-to-Case	$R_{\theta JC}$	1.81	$^\circ\text{C/W}$
Junction-to-Ambient (Note 1)	$R_{\theta JA}$	67.3	$^\circ\text{C/W}$
Maximum Soldering Temperature (MSL3)	T_{SLD}	260	$^\circ\text{C}$

1. Device on 1 in², 2 oz copper pad on single layer FR-4 PCB.

$V_{(BR)DSS}$	$R_{DS(ON)}$ TYP	I_{DS} MAX
700 V	132 mΩ	12 A

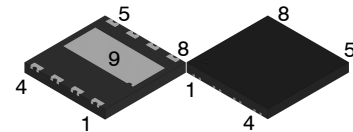
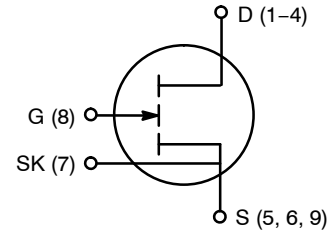

PTFO-N9 8.00 x 8.00 x 0.90, 2.00P (DFN) CASE 522AG

MARKING DIAGRAM

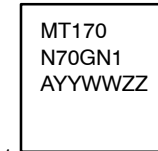

1
MT170N70GN1 = Specific Device Code
A = Assembly Location
YY = Year
WW = Work Week
ZZ = Assembly Lot

ORDERING INFORMATION

Device	Package	Shipping [†]
NTMT170N70GN1TXG	PTFO-N9 (DFN)	2500 / Tape & Reel

[†] For information on tape and reel specifications, including part orientation and tape sizes, please refer to our Tape and Reel Packaging Specification Brochure, [BRD8011/D](#).

This Preliminary document is for informational purposes only. onsemi may update or withdraw it without notice. Content and referenced products are under development and subject to change.

NTMT170N70GN1

ELECTRICAL CHARACTERISTICS (T_J = 25 °C unless otherwise specified)

Parameter	Test Conditions	Symbols	Min	Typ	Max	Unit
-----------	-----------------	---------	-----	-----	-----	------

OFF CHARACTERISTICS

Drain-to-Source Breakdown Voltage	V _{GS} = 0 V	V _{(BR)DSS}	700			V
Drain-to-Source Leakage Current	V _{GS} = 0 V, V _{DS} = 700 V	I _{DSS}		0.5	28	μA
	V _{GS} = 0 V, V _{DS} = 700 V, T _J = 125 °C			5.3		
Gate-to-Source Leakage Current	V _{GS} = 6 V, V _{DS} = 0 V	I _{GSS}		26		μA

ON CHARACTERISTICS

Drain-to-Source On Resistance	V _{GS} = 6 V, I _{DS} = 0.5 A	R _{DS(ON)}		132	170	mΩ
	V _{GS} = 6 V, I _{DS} = 4 A			132		
	V _{GS} = 6 V, I _{DS} = 4 A, T _J = 125 °C			254		
Gate Threshold Voltage	V _{DS} = V _{GS} , I _{DS} = 10.7 mA, T _J = 25 °C	V _{GS(TH)}	1.2	1.6	2.5	V
	V _{DS} = V _{GS} , I _{DS} = 10.7 mA, T _J = 125 °C			1.5		

DYNAMIC CHARACTERISTICS

Input Capacitance	V _{DS} = 400 V, V _{GS} = 0 V, f = 100 kHz	C _{ISS}		78		pF	
Output Capacitance		C _{OSS}		27			
Reverse Transfer Capacitance		C _{RSS}		0.3			
Output Capacitance, Energy Related	V _{DS} = 0 V to 400 V, V _{GS} = 0 V	C _{OSS(ER)}		38.6		pF	
Output Capacitance, Time Related		C _{OSS(TR)}		51.1			
Output Charge		Q _{OSS}		20.4			nC
Output Capacitance Stored Energy		E _{OSS}		3.1			μJ
Gate Resistance		f = 5 MHz	R _G		11		
Gate Charge	V _{DS} = 400 V, I _{DS} = 4 A, V _{GS} = 0/6 V	Q _G		2.1		nC	
Gate-to-Source Charge		Q _{GS}		0.2			
Gate-to-Drain Charge		Q _{GD}		0.8			
Gate Plateau Voltage		V _{PLAT}		2.1			V

REVERSE CONDUCTION CHARACTERISTICS

Source-to-Drain Reverse Voltage	V _{GS} = 0 V, I _{SD} = 4 A	V _{SD}		2.4		V
Pulsed Reverse Current	V _{GS} = 6 V, t _{PULSE} = 10 μs	I _{SD(PULSE)}			24	A

Product parametric performance is indicated in the Electrical Characteristics for the listed test conditions, unless otherwise noted. Product performance may not be indicated by the Electrical Characteristics if operated under different conditions.

NTMT170N70GN1

TYPICAL CHARACTERISTICS ($T_J = 25\text{ }^\circ\text{C}$ unless otherwise specified)

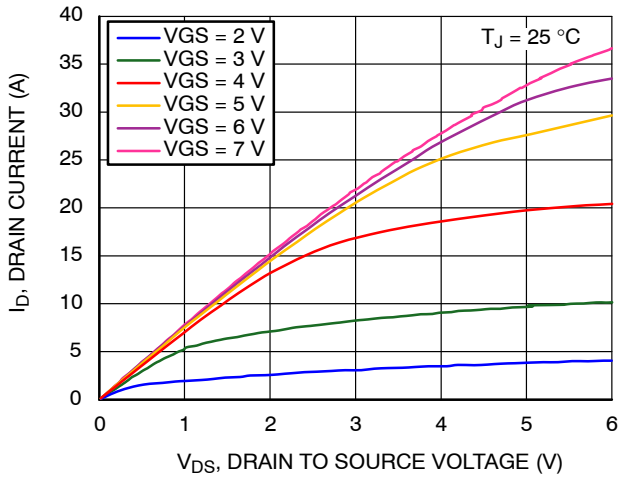

Figure 1. Output Characteristics at $T_J = 25\text{ }^\circ\text{C}$

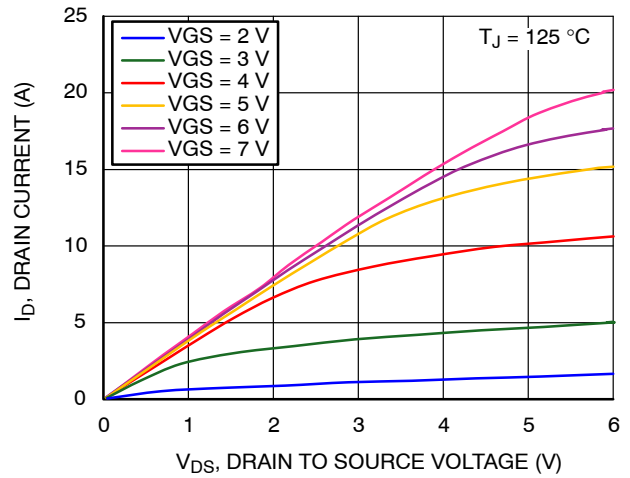

Figure 2. Output Characteristics at $T_J = 125\text{ }^\circ\text{C}$

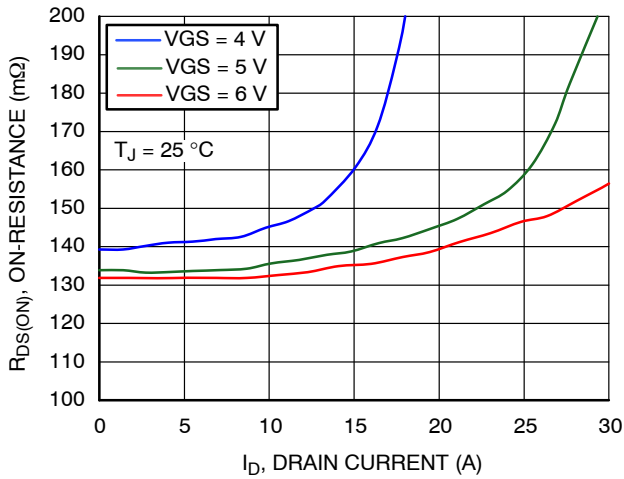

Figure 3. On-Resistance vs. Drain Current at $T_J = 25\text{ }^\circ\text{C}$

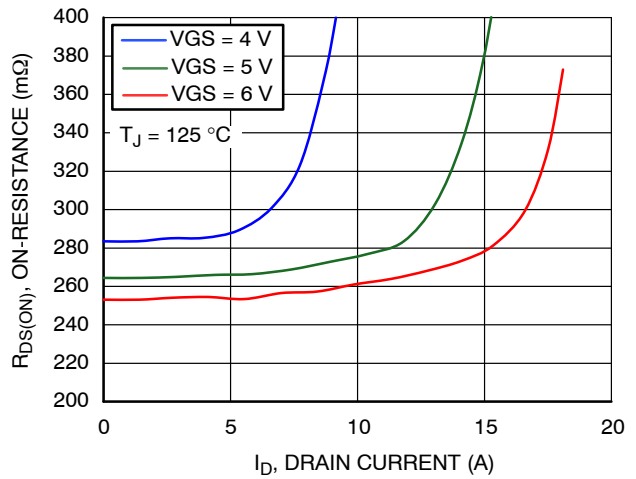

Figure 4. On-Resistance vs. Drain Current at $T_J = 125\text{ }^\circ\text{C}$

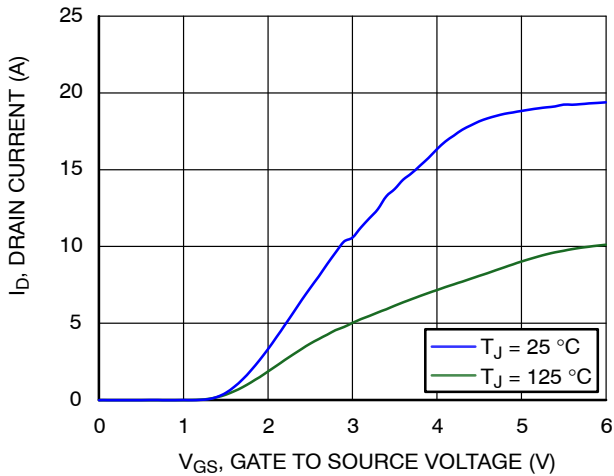

Figure 5. Transfer Characteristics at $V_{DS} = 3\text{ V}$

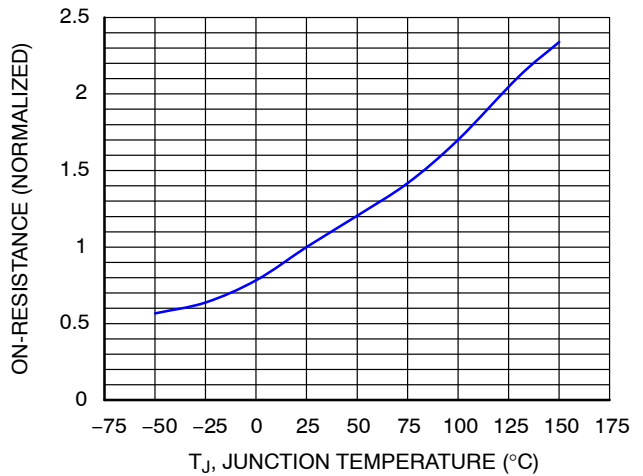

Figure 6. Normalized On-Resistance vs. Temperature at $V_{GS} = 6\text{ V}$

NTMT170N70GN1

TYPICAL CHARACTERISTICS ($T_J = 25\text{ }^\circ\text{C}$ unless otherwise specified) (continued)

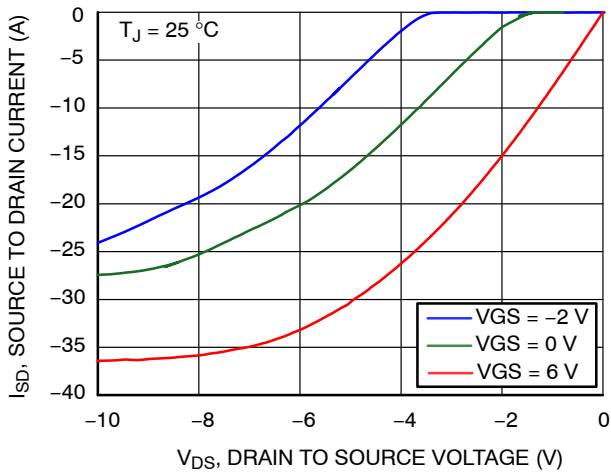

Figure 7. Reverse Conduction Characteristics at $T_J = 25\text{ }^\circ\text{C}$

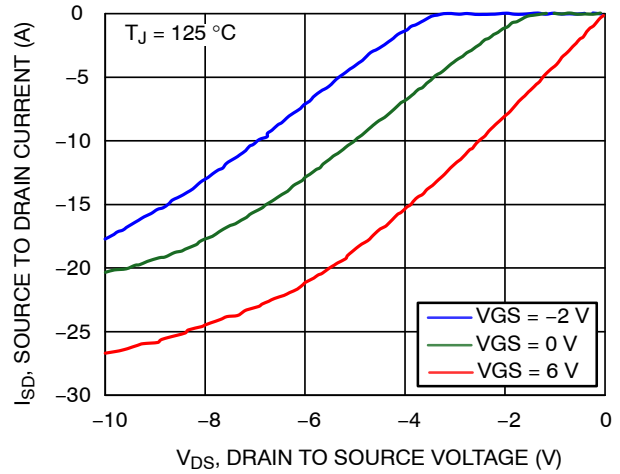

Figure 8. Reverse Conduction Characteristics at $T_J = 125\text{ }^\circ\text{C}$

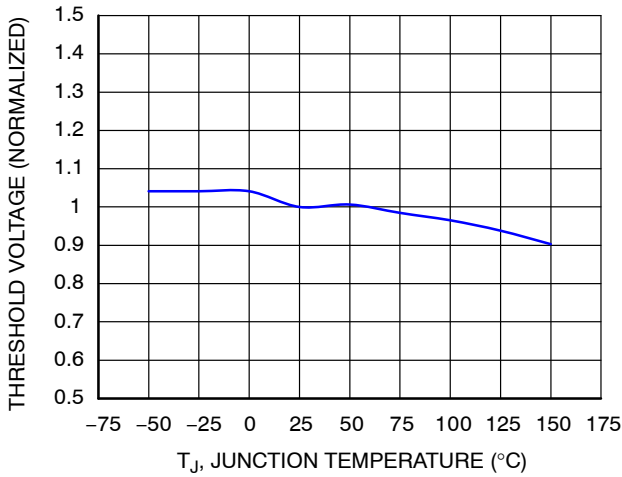

Figure 9. Normalized Threshold Voltage vs. Temperature

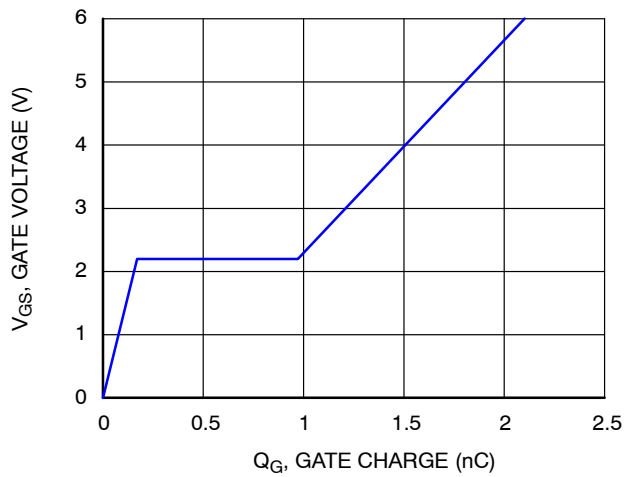

Figure 10. Gate Charge Characteristics at $I_{DS} = 20\text{ A}$

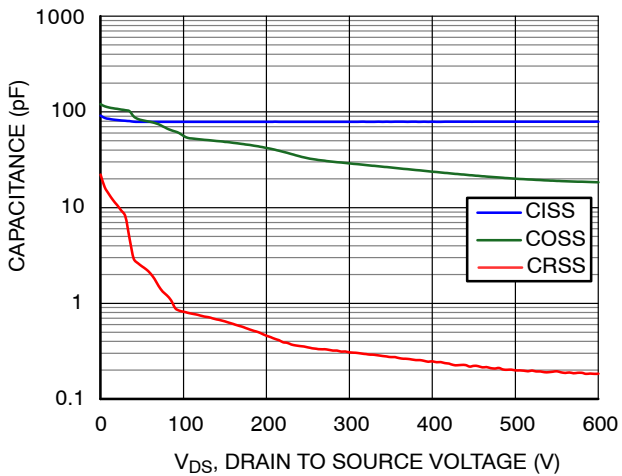

Figure 11. Capacitance Characteristics

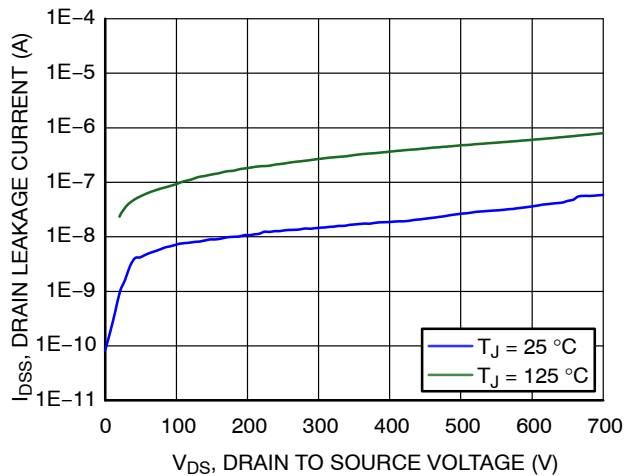

Figure 12. Drain Leakage Characteristics

NTMT170N70GN1

TYPICAL CHARACTERISTICS ($T_J = 25\text{ }^\circ\text{C}$ unless otherwise specified) (continued)

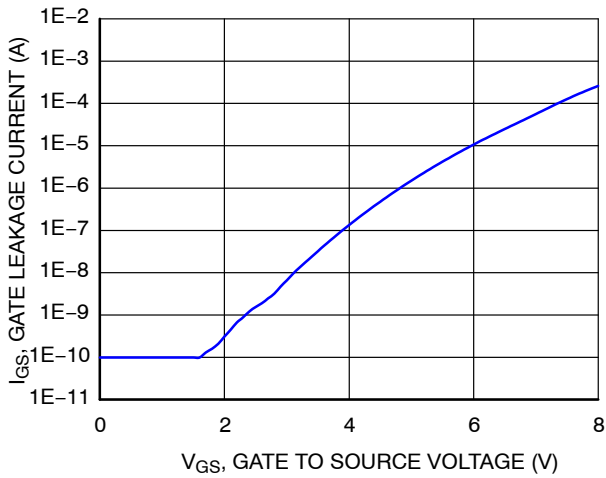

Figure 13. Gate Leakage Characteristics

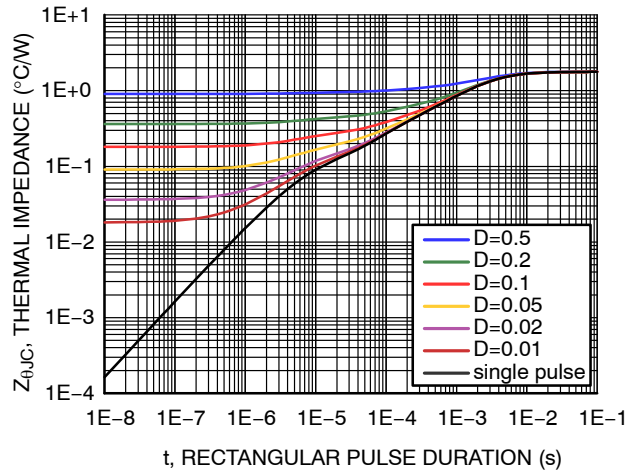

Figure 14. Transient Thermal Impedance

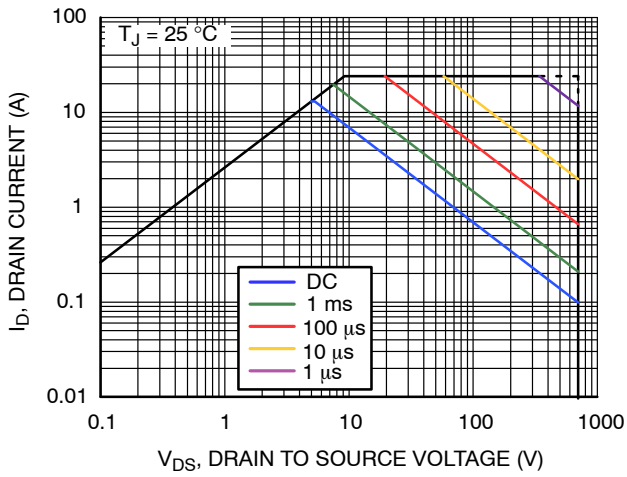

Figure 15. Safe Operating Area at $T_C = 25\text{ }^\circ\text{C}$

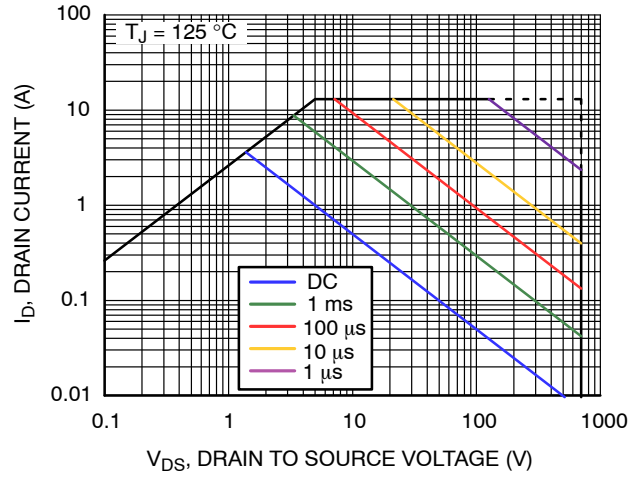

Figure 16. Safe Operating Area at $T_C = 125\text{ }^\circ\text{C}$

NTMT170N70GN1

REVISION HISTORY

Revision	Description of Changes	Date
P0	Initial Preliminary document release.	5/28/2026

NTMT170N70GN1

PTFP-N9 8.00x8.00x0.90, 2.00P
CASE 522AG
ISSUE O

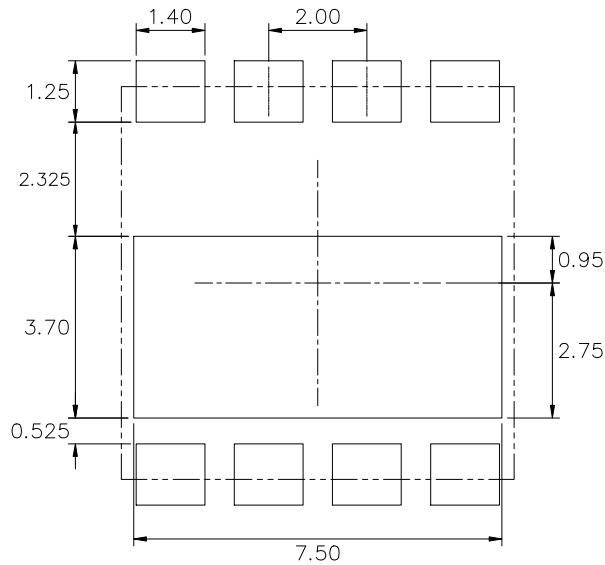
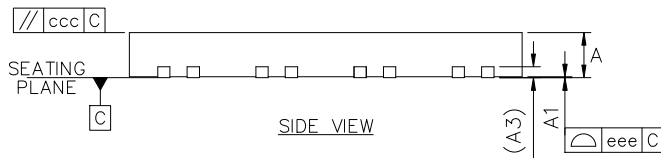
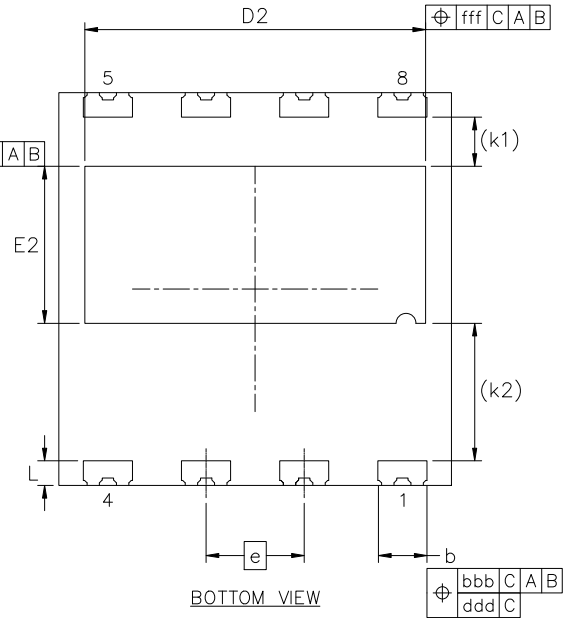
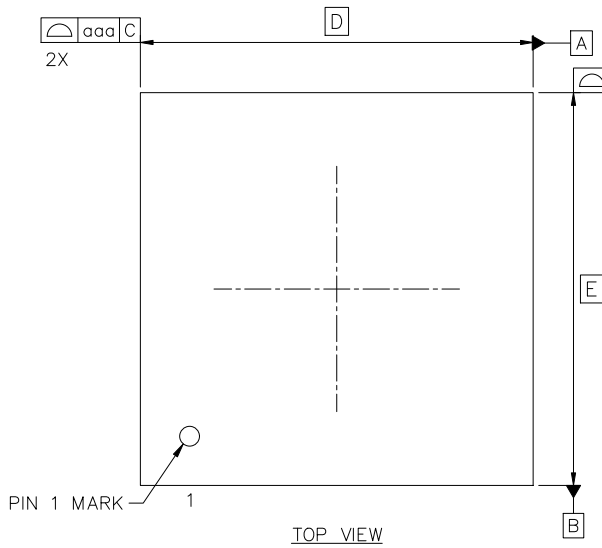

*For additional information on Pb-Free strategy and soldering details, please download the onsemi Soldering and Mounting Techniques Reference Manual, SOLDERRM/D.

NOTES:

1. ALL DIMENSION AND TOLERANCE CONFORM TO ASME Y14.5-2018.
2. ALL DIMENSION ARE IN MILLIMETERS
3. DRAWING NOT TO SCALE.
4. DIMENSION DO NOT INCLUDE MOLD PROTRUSION.
5. PACKAGE OUTLINE EXCLUSIVE OF METAL BURR DIMENSIONS.

MILLIMETER			
SYMBOL	MIN.	NOM.	MAX.
A	0.80	0.90	1.00
A1	0.00	0.02	0.05
A3	0.203 REF.		
b	0.95	1.00	1.05
D	8.00 BSC		
D2	6.84	6.94	7.04
E	8.00 BSC		
E2	3.10	3.20	3.30
e	2.00 BSC		
k1	1.00 REF.		
k2	2.80 REF.		
L	0.40	0.50	0.60
TOLERANCE FORM & POSITION			
aaa	0.10		
bbb	0.10		
ccc	0.10		
ddd	0.05		
eee	0.10		
fff	0.10		

onsemi, **Onsemi**, and other names, marks, and brands are registered and/or common law trademarks of Semiconductor Components Industries, LLC dba "**onsemi**" or its affiliates and/or subsidiaries in the United States and/or other countries. **onsemi** owns the rights to a number of patents, trademarks, copyrights, trade secrets, and other intellectual property. A listing of **onsemi**'s product/patent coverage may be accessed at www.onsemi.com/site/pdf/Patent-Marking.pdf. **onsemi** reserves the right to make changes at any time to any products or information herein, without notice. The information herein is provided "as-is" and **onsemi** makes no warranty, representation or guarantee regarding the accuracy of the information, product features, availability, functionality, or suitability of its products for any particular purpose, nor does **onsemi** assume any liability arising out of the application or use of any product or circuit, and specifically disclaims any and all liability, including without limitation special, consequential or incidental damages. Buyer is responsible for its products and applications using **onsemi** products, including compliance with all laws, regulations and safety requirements or standards, regardless of any support or applications information provided by **onsemi**. "Typical" parameters which may be provided in **onsemi** data sheets and/or specifications can and do vary in different applications and actual performance may vary over time. All operating parameters, including "Typicals" must be validated for each customer application by customer's technical experts. **onsemi** does not convey any license under any of its intellectual property rights nor the rights of others. **onsemi** products are not designed, intended, or authorized for use as a critical component in life support systems or any FDA Class 3 medical devices or medical devices with a same or similar classification in a foreign jurisdiction or any devices intended for implantation in the human body. Should Buyer purchase or use **onsemi** products for any such unintended or unauthorized application, Buyer shall indemnify and hold **onsemi** and its officers, employees, subsidiaries, affiliates, and distributors harmless against all claims, costs, damages, and expenses, and reasonable attorney fees arising out of, directly or indirectly, any claim of personal injury or death associated with such unintended or unauthorized use, even if such claim alleges that **onsemi** was negligent regarding the design or manufacture of the part. **onsemi** is an Equal Opportunity/Affirmative Action Employer. This literature is subject to all applicable copyright laws and is not for resale in any manner.

ADDITIONAL INFORMATION

TECHNICAL PUBLICATIONS:

Technical Library: www.onsemi.com/design/resources/technical-documentation
onsemi Website: www.onsemi.com

ONLINE SUPPORT: www.onsemi.com/support

For additional information, please contact your local Sales Representative at www.onsemi.com/support/sales