

NCP1014STBUCGEVB

Non-isolated Positive Output Buck AC/DC Converter Evaluation Board User's Manual



ON Semiconductor®

<http://onsemi.com>

EVAL BOARD USER'S MANUAL



Figure 1. Evaluation Board Photo

This manual describes the way, how to easily design the simple, non isolated AC/DC converter for powering low voltage control part of mains applications with triac, or SCR power switch. Some examples are: dishwashers, microwave ovens, coffee machines, night illumination and so on. In comparison with resistive, or capacitive dropper is this solution more comfortable and features some advantages such as:

- Wide Input Voltage Range 85 VAC – 265 VAC
- Smaller Size, Lower Weight, Lower Total Cost
- Good Line and Load Regulation, No Need of Additional Linear Regulators
- Efficient Design with Up to 80% Efficiency

- Overload, Short-Circuit and Thermal Protected
- Simple for Low Cost Mass Production
- Universal Design for Wide Range of Output Currents and Voltages

The monolithic power switcher, used in this application, greatly simplifies the total design and reduces time to production. The new line of the Power Switchers, NCP1010 through NCP1014, is ideal for this purpose. This IC in the SOT-223 package reduces size and is suitable for mass production. The design consists of input filter, rectifier with filtering capacitor, power stage with switcher and inductor, output ultrafast rectifier, output filtering capacitor, feedback loop with zener diode and optocoupler and indicating LED. The only component necessary for proper powering of the IC is the V_{CC} capacitor. The IC is directly powered from the HV Drain circuit via internal voltage regulator. To eliminate the noise at the feedback input, some small ceramic capacitor with value of around 1.0 nF is necessary to be connected as close to the FB pin, as possible.

SCHEMATIC DIAGRAM

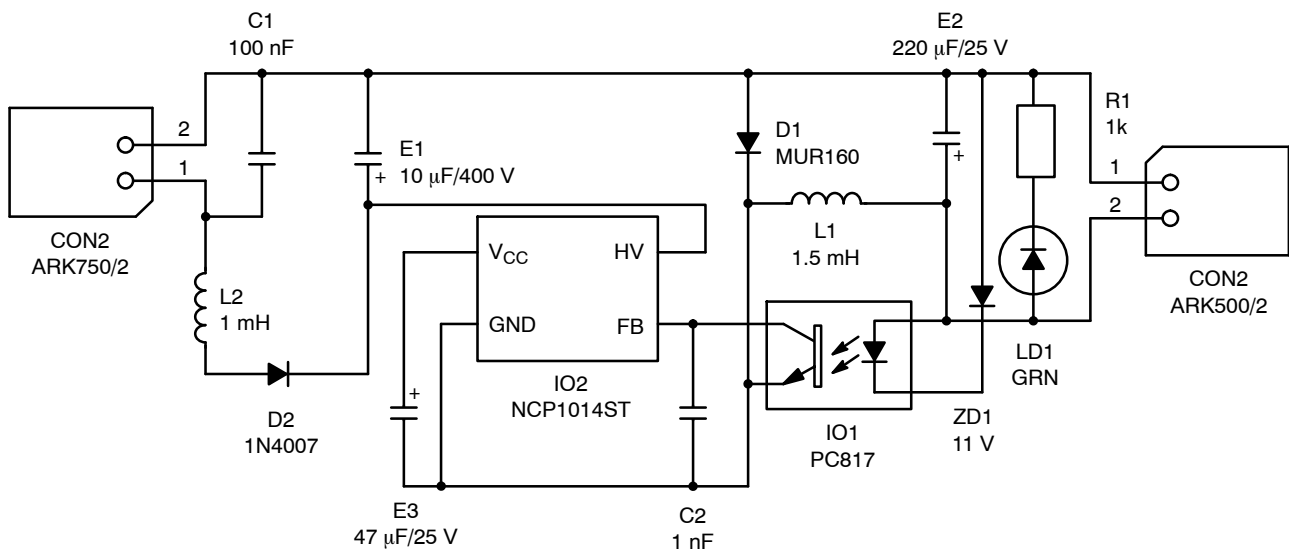

Figure 2. Complete Schematic Diagram of the 12 V/0.2 A Converter

NCP1014STBUCGEVB

SELECTION OF CRITICAL COMPONENTS

Inductor selection

For the selected output power need to be selected certain minimum value of the inductance. This value is dependent on the mode of operation. Reduced value results in Discontinuous Conduction Mode of operation (DCM). Practically was found, that the borderline between Continuous Conduction Mode of operation (CCM) and DCM is commonly set slightly below maximum output power. The result is low cost of the inductor, freewheeling diode ($t_{rr} > 35$ ns), higher efficiency and lower cost. The negative result is in lower output power and higher cost of the NCP101x Power Switcher.

The current ripple in the inductor during the T_{on} time may be expressed by Equation 1.

$$\Delta I_{ripple}(T_{on}) = T_{on} \cdot \left(\frac{(V_{min} - V_{ds} - V_O)}{L_{min}} \right) \quad (\text{eq. 1})$$

Where:

T_{on} = ON Time, Internal Power Switch in ON,

V_{min} = Minimum Rectified Input Voltage,

V_{ds} = Drain-to-Source Voltage Drop,

V_O = Output Voltage,

L_{min} = Minimum Inductor Value.

The current ripple in the inductor during the T_{off} time may be expressed by Equation 2.

$$\Delta I_{ripple}(T_{off}) = T_{off} \cdot \left(\frac{V_O}{L_{min}} \right) \quad (\text{eq. 2})$$

T_{off} = OFF Time, Internal Power Switch in OFF.

The current through the inductor at the beginning of the T_{on} time is shown by Equation 3.

$$I_{init} = I_{set} - \Delta I_{ripple} \quad (\text{eq. 3})$$

I_{set} = Peak Switching Current Set by the FB Loop.

The average current through the inductor over one switching cycle can be expressed by Equation 4.

$$I_c = f_{op_min} \cdot \left(\left(\frac{\Delta I_{ripple}}{2 + I_{init}} \right) \cdot T_{on} + \left(\frac{\Delta I_{ripple}}{2 + I_{init}} \right) \cdot T_{off} \right) \quad (\text{eq. 4})$$

I_c = Inductor Operating Current,

f_{op_min} = Minimum Operating Frequency

The theoretical minimum inductor value corresponds to Equation 5.

$$L_{min} = \frac{(2 \cdot V_O \cdot I_O \cdot (V_{min} - V_{ds} - V_O))}{(\Delta I_{ripple}^2 \cdot f_{op_min} \cdot (V_{min} - V_{ds}))} \quad (\text{eq. 5})$$

I_O = Output DC Current.

The theoretical maximum output power will be shown in Equation 6.

$$P_{out_max} = L_{min} \cdot (I_{set}^2 - I_{init}^2) \cdot f_{op_min} \cdot \frac{\left(\frac{(V_{min} - V_{ds})}{(V_{min} - V_{ds} - V_O)} \right)}{2} \quad (\text{eq. 6})$$

The current ripple in the inductor during the normal operation will be shown in Equation 7.

$$\Delta I_{ripple} = \frac{((V_{min} - V_{ds} - V_O) \cdot V_O)}{((V_{min} - V_{ds}) \cdot f_{op_min} \cdot L_{min})} \quad (\text{eq. 7})$$

The output current will be shown in Equation 8.

$$I_O = f_{op_min} \cdot \frac{((I_{set} + I_{init}) \cdot T_{on} + (I_{set} + I_{init}) \cdot T_{off})}{2} \quad (\text{eq. 8})$$

Table 1. TABLE OF PRESELECTED INDUCTORS ($V_{min} = 120$ V, $V_{ds} = 9$ V, $V_O = 12$ V, $I_{set} = 0.405$ A, $f_{op_min} = 59$ kHz)

Inductance (μ H)	Coilcraft Part Number (see appendix for address)	ΔI_{ripple} (A)	Output Current (A)
470	RFB0810-471	0.39	0.25
680	RFB0810-681	0.27	0.32
820	RFB0810-821	0.22	0.34
1000	RFB0810-102	0.18	0.36
1500	RFB0810-152	0.12	0.40

NOTE: The output current is the theoretical value and need to be multiplied by the efficiency (~0.7).

NCP1014STBUCGEVB

Freewheeling diode selection

The freewheeling diode needs to be selected accordingly to the mode of operation. For the CCM operation needs to be used the ultra fast diode with $t_{rr} < 35$ ns. For the DCM operation the standard ultra fast diode with $t_{rr} < 75$ ns is enough.

Table 2. TABLE OF PRESELECTED FREEWHEELING DIODES

Part number	V_{RRM} (V)	$I_{F(AV)}$ (A)	t_{rr} (ns)	Package
MUR160	600	1.0	75	Axial Lead
MURA160T3	600	1.0	75	SMD SMA
MURS160T3	600	1.0	75	SMD SMB
MURS260T3	600	2.0	75	SMD SMB

Electrical Specification of the example at Figure 2:

Input: 85 VAC – 265 VAC

Output: + 12 V / 200 mA

NOTE: The polarity is proportional to common line.

COMPONENT LAYOUT

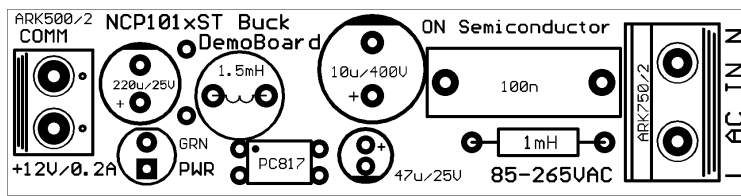

Figure 3. Component Layout – Top Side

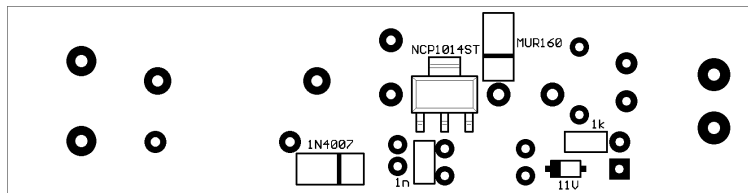

Figure 4. Component Layout – Bottom Side

PCB LAYOUT

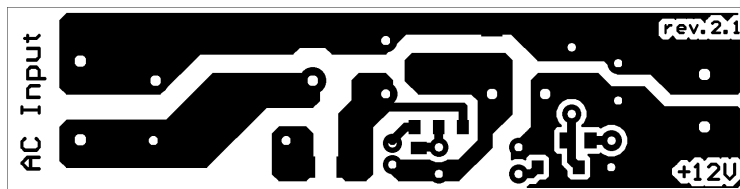
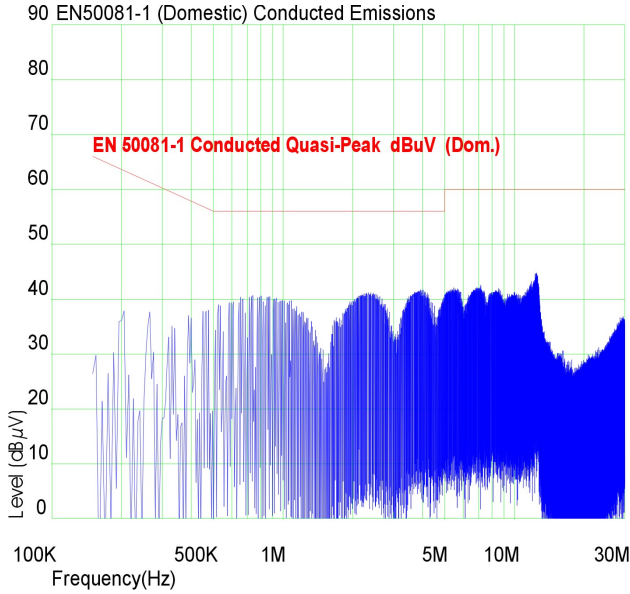

Figure 5. PCB Layout

NCP1014STBUCGEVB

EMI TEST RESULTS



Test Conditions:
 Input: 230 VAC
 Output: 11.7 VDC
 Load: Resistive 68 R

Figure 6. Conducted EMI

TEST PROCEDURE

Necessary Equipment:

- 1 Current limited 90 – 265 Vrms AC source (current limited to avoid board destruction in case of a defective part) or a 380 VDC source (e.g. AGILENT 681x)
- 1 AC Volt-Meter able to measure up to 300 V AC (e.g. KEITHLEY 2000)
- 1 AC Amp-Meter able to measure up to 1 A AC (e.g. KEITHLEY 2000)
- 1 DC Volt-Meter able to measure up to 20 V DC (e.g. KEITHLEY 2000)
- 1 DC Amp-Meter able to measure up to 500 mA DC (e.g. KEITHLEY 2000)
- 1 DC Electronic Load (e.g. AGILENT 6060B)

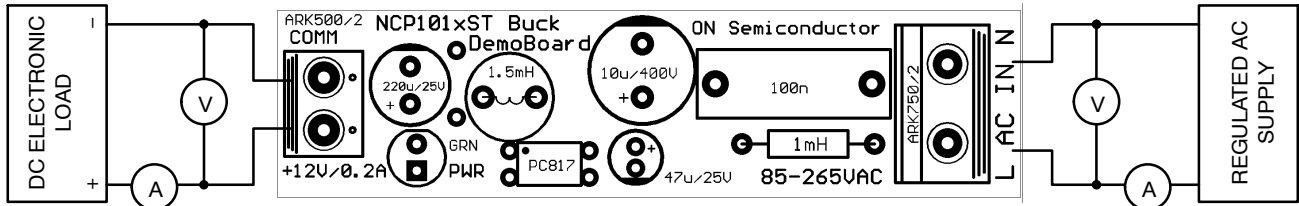

Figure 7. Test Setup

Test Procedure

- Connect the test setup as shown in Figure 7.
- Apply an input voltage, $U_{in} = 90 - 265 \text{ Vac}$
- Apply $I_{out}(\text{load}) = 0 \text{ A}$
- Check that U_{out} is 12 Vdc
- Increase $I_{out}(\text{load})$ load to: 12 V / 200 mA
- Check that U_{out} is 12 V

- Power down the load
- Power down U_{in}
- End of test

NOTE: Be careful when manipulating the boards in operation, lethal voltages up to 265 Vac are present on the primary side.

NCP1014STBUCGEVB

BILL OF MATERIAL

Table 3. NCP1014STBUCGEVB EVALUATION BOARD BILL OF MATERIALS

Designator	QTY	Description	Value	Tolerance	Footprint	Manufacturer	Manufacturer Part Number	Substitution Allowed	RoHS Compliant
C1	1	Capacitor X2	100 nF	±10%	Through Hole	Vishay	F1772-410-2030	Yes	Yes
C2	1	CMS Capacitor	1 nF	±10%	1206	AVX	12065C102KAT2A	Yes	Yes
CON1	1	Input Terminal Block	LP7.5/2/903.2 OR	-	LP7.5/2	WeidMuller	LP7.5/2/903.2 OR	Yes	Yes
CON2	1	Output Terminal Block	PM5.08/2/90	-	PM5.08/2	WeidMuller	PM5.08/2/90	Yes	Yes
D1	1	Ultrafast Power Rectifier	MURA160	-	SMA	ON Semiconductor	MURA160T3G	No	Yes
D2	1	1 A, 1000 V Standard Rectifier	1N4007	-	Axial Lead	ON Semiconductor	1N4007RLG	No	Yes
E1	1	Electrolytic Capacitor	10 uF / 400 V	±20%	Through Hole	Panasonic	ECA2GHG100	Yes	Yes
E2	1	Electrolytic Capacitor	220 uF / 25 V	±20%	Through Hole	Panasonic	ECA1EHG221	Yes	Yes
E3	1	Electrolytic Capacitor	47 uF / 25 V	±20%	Through Hole	Rubycon	25ML47M6.3X5	Yes	Yes
IO1	1	Opto-Coupler	PC817	-	DIL-4	Sharp	PC817X1J000F	Yes	Yes
IO2	1	Monolithic Power Switcher	NCP1014	-	SOT-223	ON Semiconductor	NCP1014ST65T3G	No	Yes
L1	1	Inductor	1.5 mH	±10%	RFB0810	Coil Craft	RFB0810-152	Yes	Yes
L2	1	Inductor	1 mH / 1.6 A	±10%	Through Hole	Fastron	SMCC-R10X-YY	Yes	Yes
LD1	1	LED	Green LED 5 mm	-	Through Hole	Avago	HLMP-HM57-SV000	Yes	Yes
R1	1	CMS Resistor	1 kΩ	±1%	1206	Vishay	RCA12061K00FKEA	Yes	Yes
ZD1	1	Zener Diode	11 V	±5%	SOD-123	ON Semiconductor	MMSZ11T1G	No	Yes

onsemi, **Onsemi**, and other names, marks, and brands are registered and/or common law trademarks of Semiconductor Components Industries, LLC dba "**onsemi**" or its affiliates and/or subsidiaries in the United States and/or other countries. **onsemi** owns the rights to a number of patents, trademarks, copyrights, trade secrets, and other intellectual property. A listing of **onsemi**'s product/patent coverage may be accessed at www.onsemi.com/site/pdf/Patent-Marking.pdf. **onsemi** is an Equal Opportunity/Affirmative Action Employer. This literature is subject to all applicable copyright laws and is not for resale in any manner.

The evaluation board/kit (research and development board/kit) (hereinafter the "board") is not a finished product and is not available for sale to consumers. The board is only intended for research, development, demonstration and evaluation purposes and will only be used in laboratory/development areas by persons with an engineering/technical training and familiar with the risks associated with handling electrical/mechanical components, systems and subsystems. This person assumes full responsibility/liability for proper and safe handling. Any other use, resale or redistribution for any other purpose is strictly prohibited.

THE BOARD IS PROVIDED BY ONSEMI TO YOU "AS IS" AND WITHOUT ANY REPRESENTATIONS OR WARRANTIES WHATSOEVER. WITHOUT LIMITING THE FOREGOING, ONSEMI (AND ITS LICENSORS/SUPPLIERS) HEREBY DISCLAIMS ANY AND ALL REPRESENTATIONS AND WARRANTIES IN RELATION TO THE BOARD, ANY MODIFICATIONS, OR THIS AGREEMENT, WHETHER EXPRESS, IMPLIED, STATUTORY OR OTHERWISE, INCLUDING WITHOUT LIMITATION ANY AND ALL REPRESENTATIONS AND WARRANTIES OF MERCHANTABILITY, FITNESS FOR A PARTICULAR PURPOSE, TITLE, NON-INFRINGEMENT, AND THOSE ARISING FROM A COURSE OF DEALING, TRADE USAGE, TRADE CUSTOM OR TRADE PRACTICE.

onsemi reserves the right to make changes without further notice to any board.

You are responsible for determining whether the board will be suitable for your intended use or application or will achieve your intended results. Prior to using or distributing any systems that have been evaluated, designed or tested using the board, you agree to test and validate your design to confirm the functionality for your application. Any technical, applications or design information or advice, quality characterization, reliability data or other services provided by **onsemi** shall not constitute any representation or warranty by **onsemi**, and no additional obligations or liabilities shall arise from **onsemi** having provided such information or services.

onsemi products including the boards are not designed, intended, or authorized for use in life support systems, or any FDA Class 3 medical devices or medical devices with a similar or equivalent classification in a foreign jurisdiction, or any devices intended for implantation in the human body. You agree to indemnify, defend and hold harmless **onsemi**, its directors, officers, employees, representatives, agents, subsidiaries, affiliates, distributors, and assigns, against any and all liabilities, losses, costs, damages, judgments, and expenses, arising out of any claim, demand, investigation, lawsuit, regulatory action or cause of action arising out of or associated with any unauthorized use, even if such claim alleges that **onsemi** was negligent regarding the design or manufacture of any products and/or the board.

This evaluation board/kit does not fall within the scope of the European Union directives regarding electromagnetic compatibility, restricted substances (RoHS), recycling (WEEE), FCC, CE or UL, and may not meet the technical requirements of these or other related directives.

FCC WARNING – This evaluation board/kit is intended for use for engineering development, demonstration, or evaluation purposes only and is not considered by **onsemi** to be a finished end product fit for general consumer use. It may generate, use, or radiate radio frequency energy and has not been tested for compliance with the limits of computing devices pursuant to part 15 of FCC rules, which are designed to provide reasonable protection against radio frequency interference. Operation of this equipment may cause interference with radio communications, in which case the user shall be responsible, at its expense, to take whatever measures may be required to correct this interference.

onsemi does not convey any license under its patent rights nor the rights of others.

LIMITATIONS OF LIABILITY: **onsemi** shall not be liable for any special, consequential, incidental, indirect or punitive damages, including, but not limited to the costs of requalification, delay, loss of profits or goodwill, arising out of or in connection with the board, even if **onsemi** is advised of the possibility of such damages. In no event shall **onsemi**'s aggregate liability from any obligation arising out of or in connection with the board, under any theory of liability, exceed the purchase price paid for the board, if any.

The board is provided to you subject to the license and other terms per **onsemi**'s standard terms and conditions of sale. For more information and documentation, please visit www.onsemi.com.

ADDITIONAL INFORMATION

TECHNICAL PUBLICATIONS:

Technical Library: www.onsemi.com/design/resources/technical-documentation
onsemi Website: www.onsemi.com

ONLINE SUPPORT: www.onsemi.com/support

For additional information, please contact your local Sales Representative at www.onsemi.com/support/sales