

SECO-NCP51530HB-GEVB Evaluation Board User's Manual



ON Semiconductor®

www.onsemi.com

Description

This evaluation board is a part of system level support for applications in which high voltage (half bridge) gate driver is required. Its purpose is to simplify and accelerate design phase of switching parts (gate driver + power device) in application. The board showcases the Half-Bridge gate driver NCP51530 and two different MOSFET packages (DFN5 and WDFN8), with numerous test points, board offers simplified selection process for gate driver and power device, in order to obtain optimal performance. User is able to adjust gate resistances, bootstrap circuit and dead time and to monitor switching behavior. This daughter card is compatible with the SECO-GDBB-EVB gate drivers' baseboard, which allows testing up to 3 half bridge daughter cards simultaneously and comparing performances.

Features

- NCP51530 High/Low Side Gate Driver
- 2 Different MOSFET Packages
- Adjustable Gate Resistance
- Adjustable Dead Time (Through External Resistors and Capacitor)
- Adjustable Bootstrap
- Gate Current and Gate Voltage Measurement
- Interface to Baseboard (Plug and Play)

Table 1. AVAILABLE GATE DRIVERS

Gate Driver	Package
NCP51530	DFN10 4x4

Table 2. AVAILABLE FOOTPRINTS FOR MOSFETS

Footprint	MOSFETS
DFN5 (SO-8FL)	NVMFS6H800NL (Note 1)
WDFN8 (μ 8FL)	NVTFS5C453NL (Note 2)

1. [168](#) MOSFETs available in this package from ON Semiconductor.
2. [65](#) MOSFETs available in this package from ON Semiconductor.

EVAL BOARD USER'S MANUAL



Figure 1. Evaluation Board Photo

EVBUM2703/D

Schematic

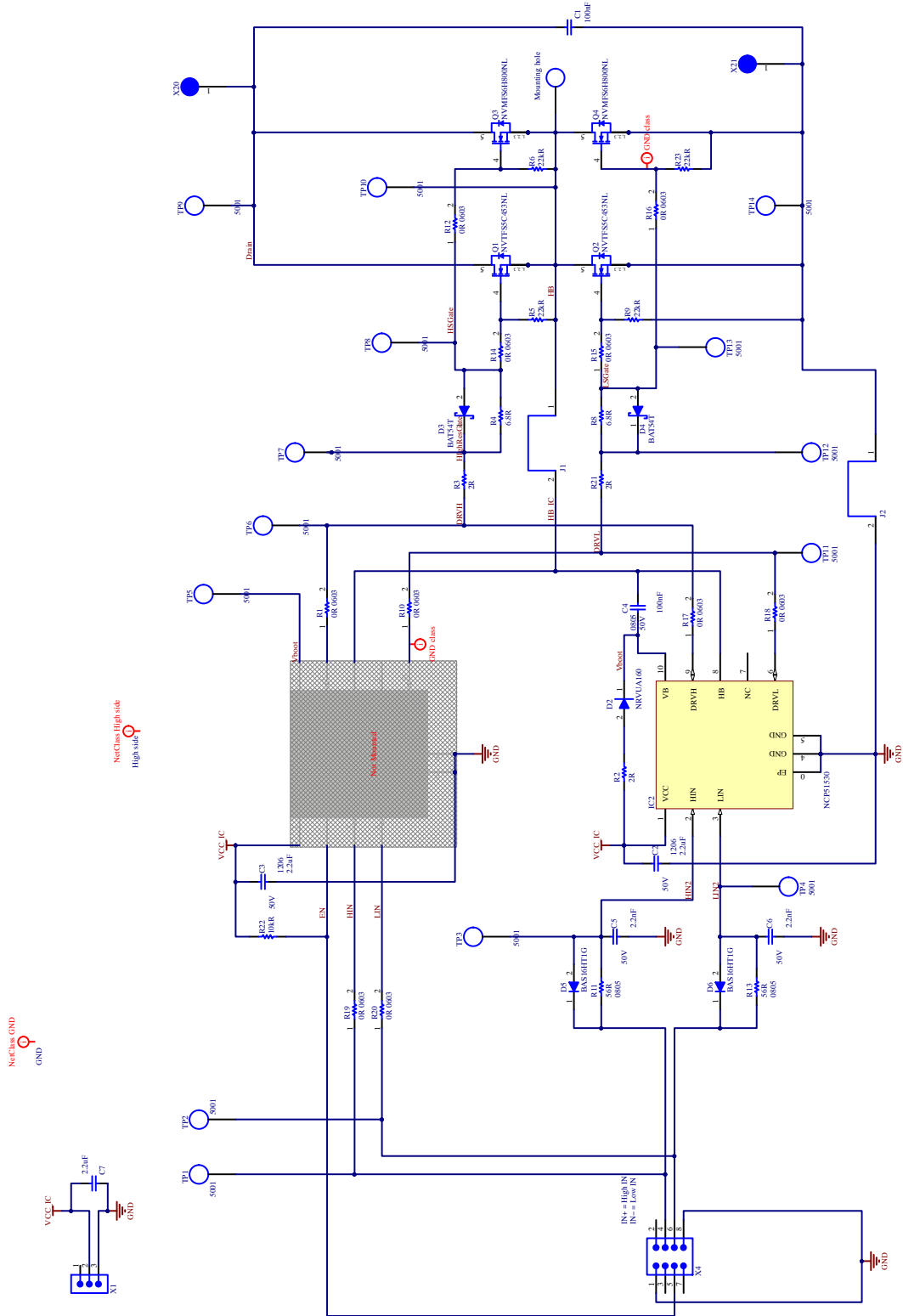

Figure 2. EVB Schematic

I/O Connectors

Table 3. DESCRIPTION OF CONNECTORS' PINS

Ref Des	Pin	Name	Type	Description
X1	1	Not used	Na	Na
X1	2	VCC_IC	Power	Voltage supply +15 V
X1	3	GND	Power	Voltage supply reference
X4	1	GND	Power	Voltage reference for control signals
X4	2	Not used	Na	Na
X4	3	Not used	Na	Na
X4	4	HIN	Input	High side control
X4	5	EN	Input	Enable
X4	6	LIN	Input	Low side control
X4	7	Not used	Na	Na
X4	8	GND	Power	Voltage reference for control signals
X20	1	VDC	Power	Half bridge DC bus voltage
X21	1	GND	Power	Half bridge GND reference
Mounting hole	1	HB	Load	Half bridge load connection

Gate Driver and MOSFET Selection

This EVB consists of half bridge gate driver NCP51530 and two MOSFET package footprints:

- μ 8FL
- SO8FL

User has multiple variants with MOSFETs in noted footprints.

To use **NCP51530** driver, place:

- R11 (value is defined based on dead time requirement),
- R13 (value is defined based on dead time requirement),
- R17 (0 Ω resistor),
- R18 (0 Ω resistor).

Remove:

- R1, R10, R19, R20

To use **μ 8FL** package place:

- R14 (0 Ω resistor),
- R15 (0 Ω resistor)

Remove:

- R12, R16

To use **SO8FL** package place:

- R12 (0 Ω resistor),
- R16 (0 Ω resistor)

Remove:

- R14, R15

Dead Time Setup

We use RC circuit with C = 2.2 nF. To choose resistor based on t_{dead} , use following formula:

$$R = \frac{t_{dead}}{0.693 \times 2.2 \text{ nF}} \quad (\text{eq. 1})$$

Default values for R11 and R133 are 56 Ω (for 80 ns dead time, same as NCV51513 driver).

Adjust dead time in accordance with application (gate resistors, load, switching frequency, etc.).

Test Points Description

Table 4. TEST POINTS

Test Point	Description
TP1	High side control input
TP2	Low side control input
TP3	High side control input with dead time delay for NCP51530
TP4	Low side control input with dead time delay for NCP51530
TP5	Bootstrap voltage (measure in respect to half bridge TP10)
TP6	High side drive
TP7	High side drive after gate resistor (R3 – current measurement, differential)
TP8	High side gate (on MOSFET side)
TP9	Drain voltage
TP10	Half bridge
TP11	Low side drive
TP12	Low side drive after gate resistor (R21 – current measurement, differential)
TP13	Low side gate (on MOSFET side)
TP14	GND

Measurement Instructions

High Side Gate: Use differential probe and measure between TP8 and TP10

High Side Current: Use differential probe and measure between TP6 and TP7 or use Rogowski coil and measure around J1

Low Side Gate: Measure between TP13 and TP14

Low Side Current: Use differential probe and measure between TP11 and TP12 or use Rogowski coil and measure around J2

Bootstrap Voltage: Use differential probe and measure between TP5 and TP10

Sizing Turn ON Gate Resistor

Turn on resistor is chosen to obtain the desired switching time. Depends on supply voltage, gate threshold voltage and Miller capacitance.

$$R_{total} = \frac{V_{DD} - V_{gs(th)}}{C_{rss} \times \frac{dV_{Out}}{dt}} \quad (eq. 2)$$

$$R_{total} = R_{drv} + R_{ON}$$

$$R_{drv} = 1.7 \Omega$$

Sizing Turn OFF Gate Resistor

Turn OFF resistor must be sized according to the application worst case. Equation relates gate threshold voltage to the drain dv/dt.

$$R_{gOFF} \leq \frac{V_{gs(th)}}{C_{gd} \times \frac{dV_{OUT}}{dt}} - R_{drv} \quad (eq. 3)$$

Other possibility is to define these values to obtain maximum peak gate current.

$$I_{peak} = \frac{V_{CC}}{R_{gate}} \quad (eq. 4)$$

Selecting Bootstrap Capacitor

The bootstrap capacitor is charged every time the low side driver is on and the half-bridge pin is below the supply voltage of the gate driver (VCC_IC). The bootstrap capacitor is discharged only when the high side switch is turned on. It is the supply voltage for the high side circuit section. The first parameter to take care of is voltage drop on capacitor during its discharge. Maximum voltage drop depends on the minimum gate driver voltage to maintain and voltage drop on bootstrap diode. The value of bootstrap capacitor is calculated by:

$$C_{boot} = \frac{Q_{TOTAL}}{\Delta V_{boot}} \quad (eq. 5)$$

where Q_{TOTAL} is the total amount of the charge supplied by the capacitor. Depends mainly on gate charge and leakage currents in bootstrap circuit.

Selecting Bootstrap Resistor

Bootstrap resistor limits the peak current, introduces an additional voltage drop and increases charging time for the capacitor. All these effects should be taken into consideration when calculating its value.

Selecting Bootstrap Diode

Bootstrap diode must be able to block DC bus voltage, is the first requirement. Other requirements are fast recovery, low parasitic capacitance and low reverse current.

Test Results – Setup 1

Gate Driver:	NCP51530B
Supply Voltage:	15 V
Switching Frequency:	100 kHz
Duty Cycle:	50%
Turn ON Resistance:	9.4 Ω
Turn OFF Resistance:	4.7 Ω
Switching Power Device:	NVMFS6H800NL
Half Bridge Supply:	30 V
Load:	No load
Temperature:	25°C

Values for gate resistors are defined in a conservative way. User shall calculated them to meet application requirements.

Delay Input/Output

Input Rising Threshold	1.7 V Typical
Input Falling Threshold	1.4 V Typical
Input Hysteresis	1.3 V

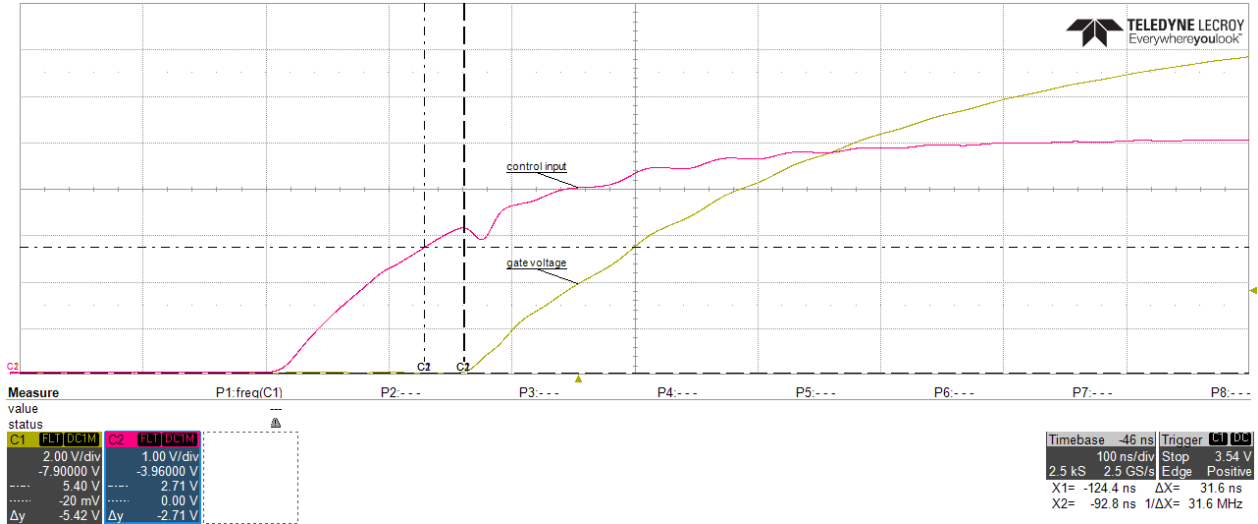

Figure 3. Delay Propagation – Low Side

Propagation delay: **31.6 ns** (measured from the moment rising threshold triggered to the moment gate voltage starts rising).

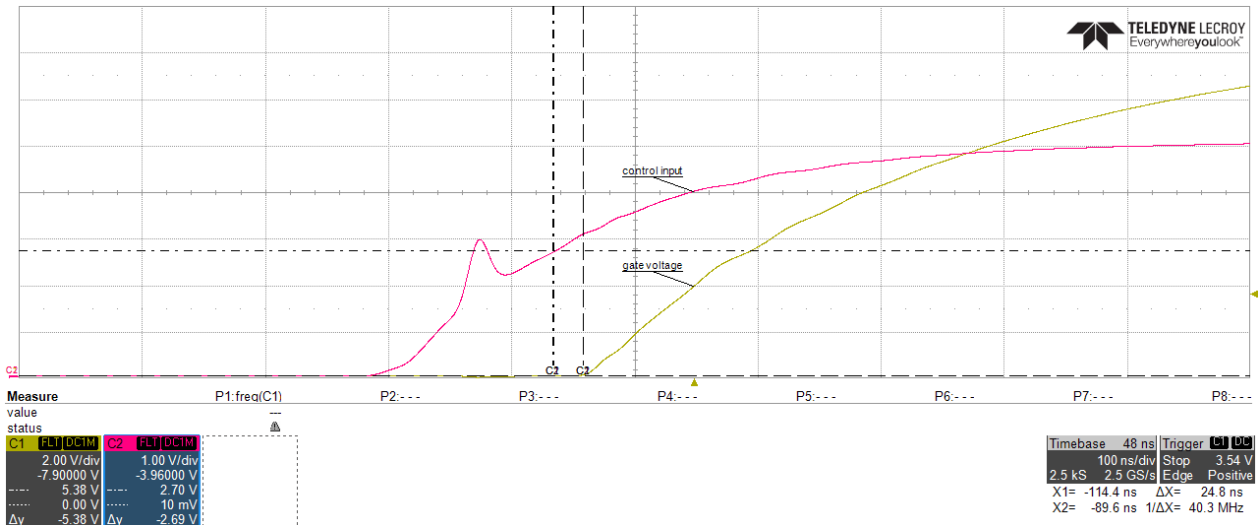

Figure 4. Delay Propagation – High Side

Propagation delay: **24.8 ns** (measured from the moment rising threshold triggered to the moment gate voltage starts rising).

Delay matching: $31.6 - 24.8 = 6.8 \text{ ns}$

Gate Peak Current

Currents measured differentially across 4.7 Ω gate resistor.

Peak Turn ON Current	Rg = 9.4 Ω	1.1 A
Peak Turn OFF Current	Rg = 4.7 Ω	1.6 A

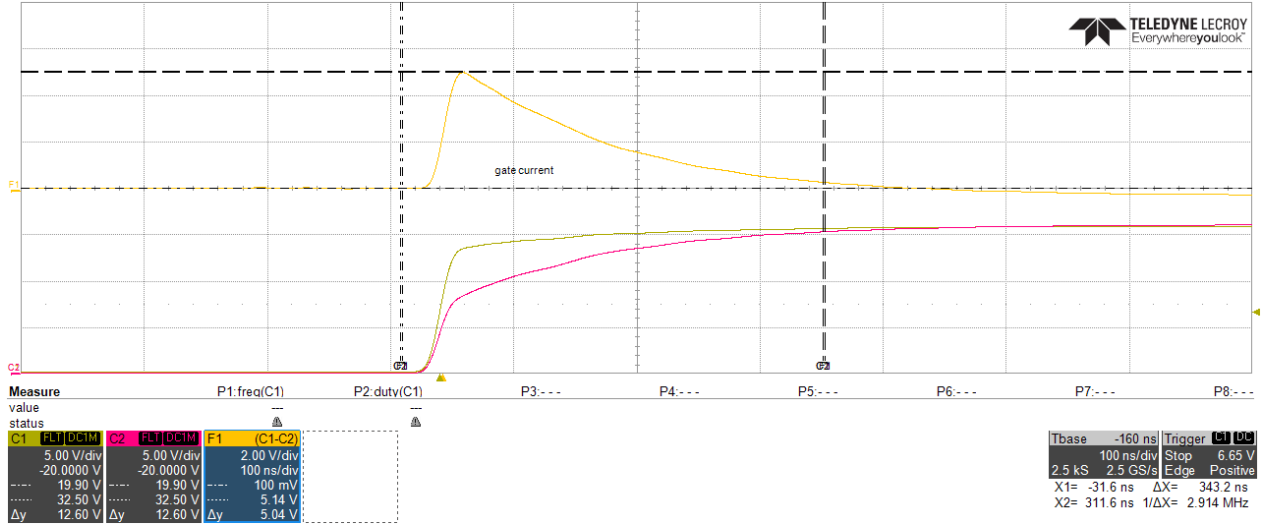

Figure 5. Turn ON Gate Current

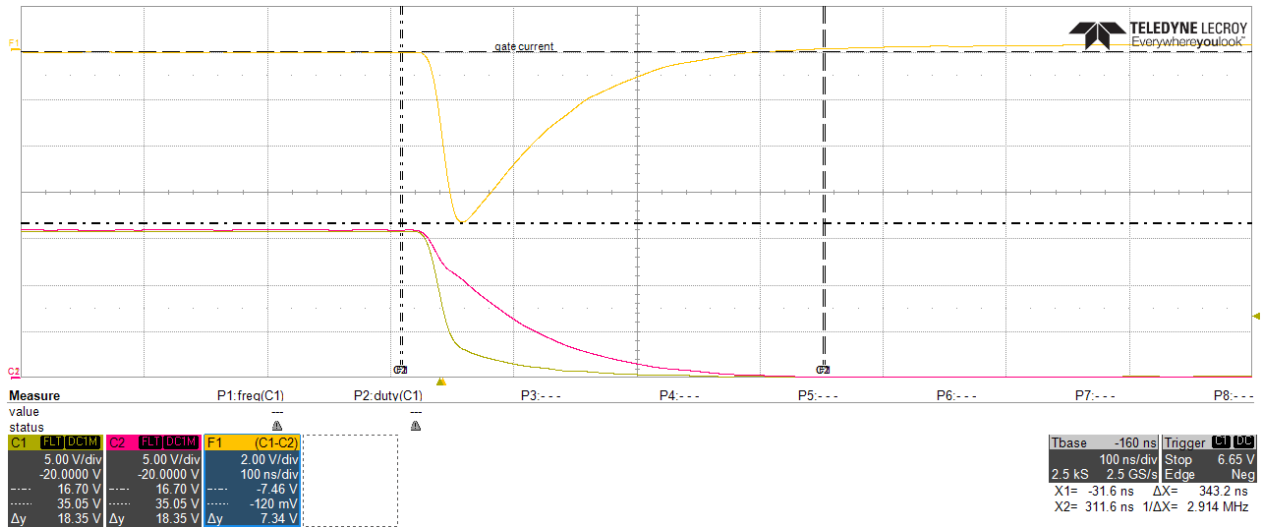

Figure 6. Turn OFF Current

EVBUM2703/D

Dead Time

Time between falling threshold of low side (1.4 V) and rising threshold of high side (2.7 V), **78.4 ns**.

Components values for dead time are: $R11 = R13 = 56 \Omega$, $C = 2.2 \text{ nF}$. User can define these values to meet application requirements.

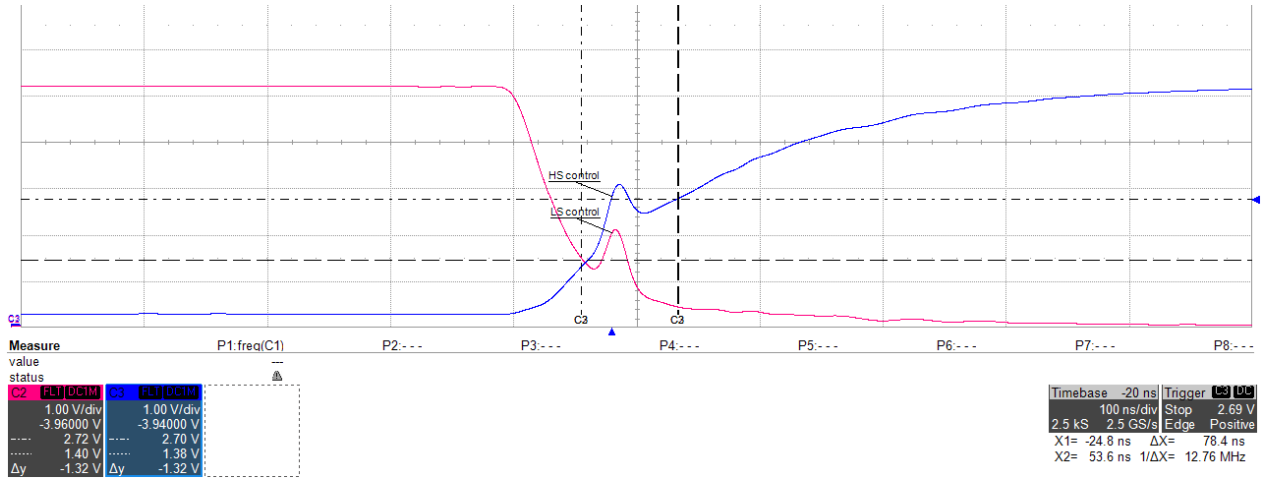

Figure 7. Dead Time Control

Test Setup 2:

- Resistive load 220 Ω
- Supply voltage 20 V
- MOSFET: NVMFS6H800NL

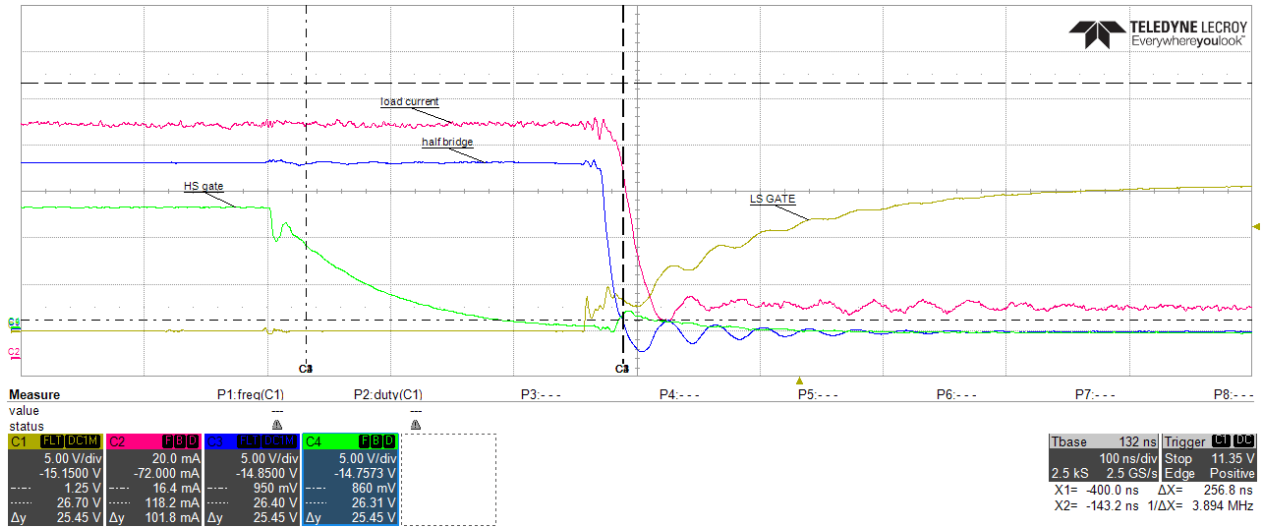

Figure 8. Turn OFF Switching Node

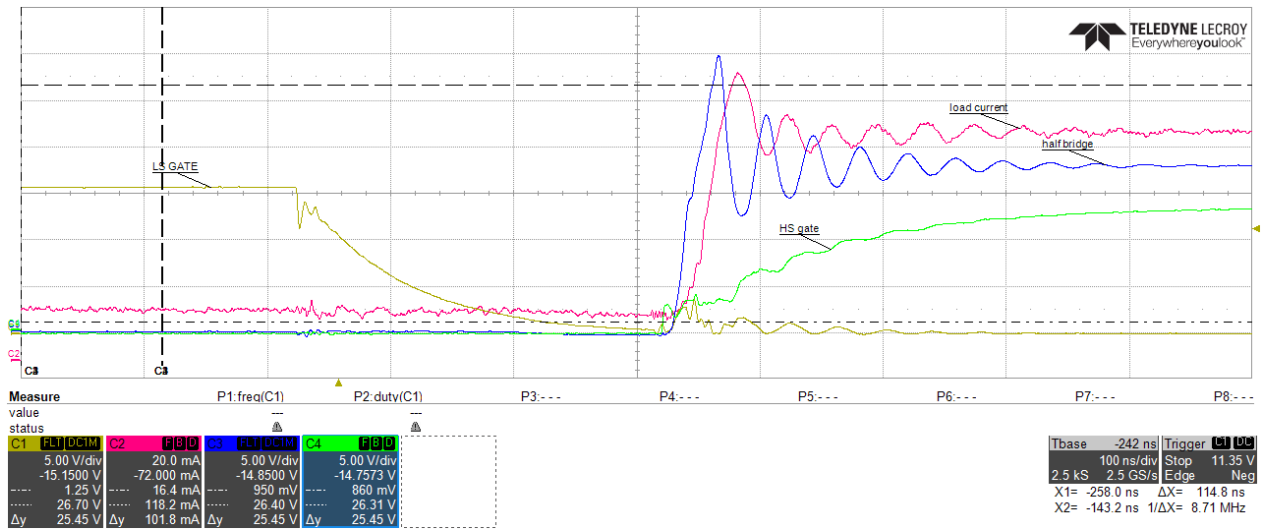

Figure 9. Turn ON Switching Node

Figure 8 and Figure 9 present rising and falling times of a half bridge under low load (100 mA).

EVBUM2703/D

PCB ASSEMBLY

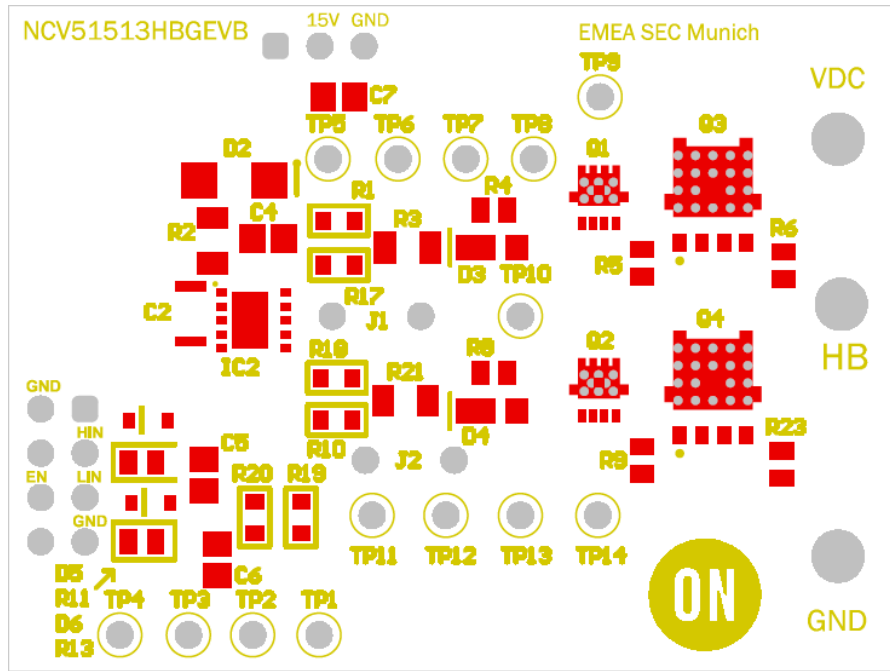

Figure 10. Top Side Assembly

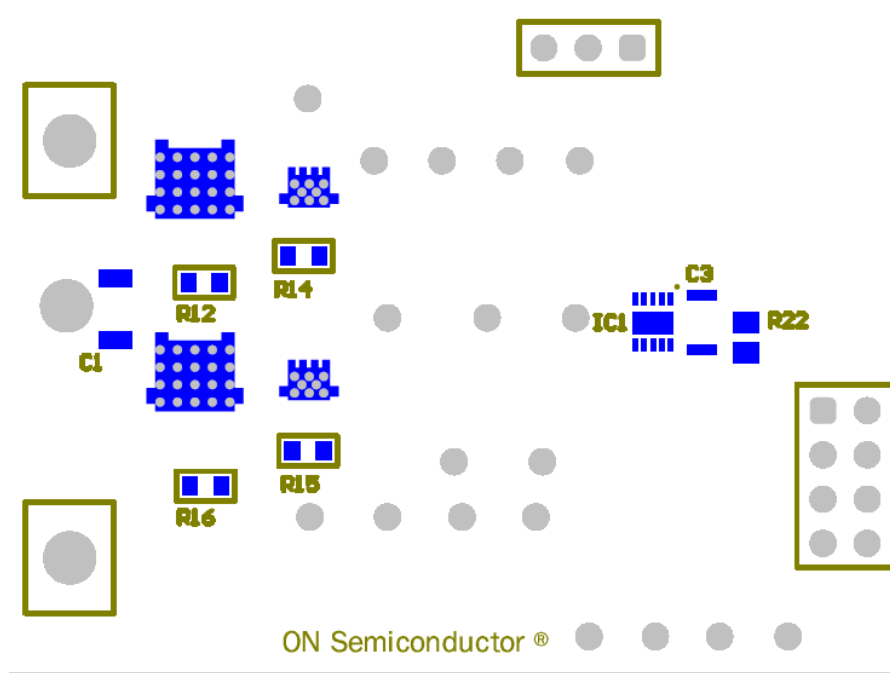

Figure 11. Bottom Side Assembly

EVBUM2703/D

3D VIEW

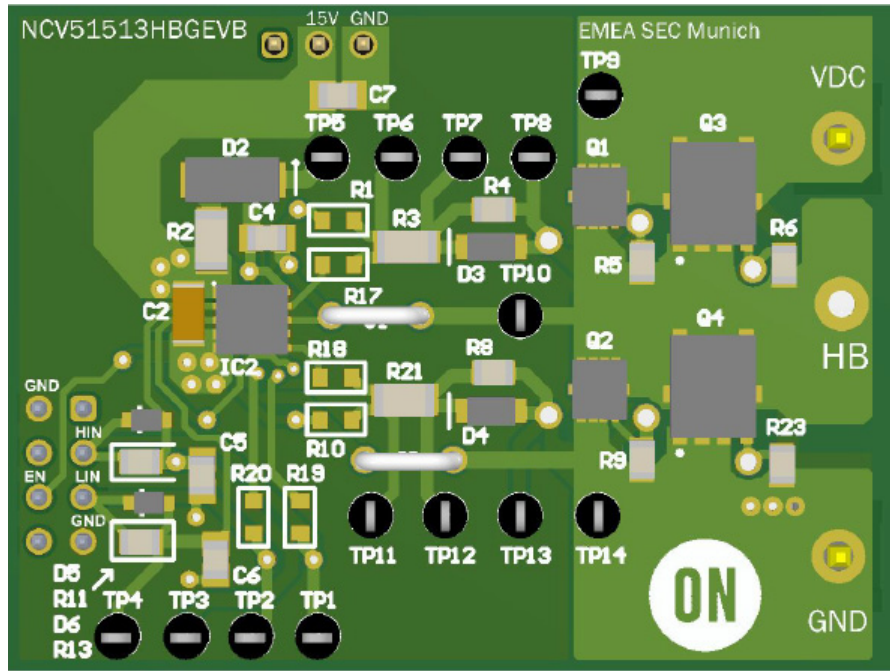

Figure 12. Board Top Side

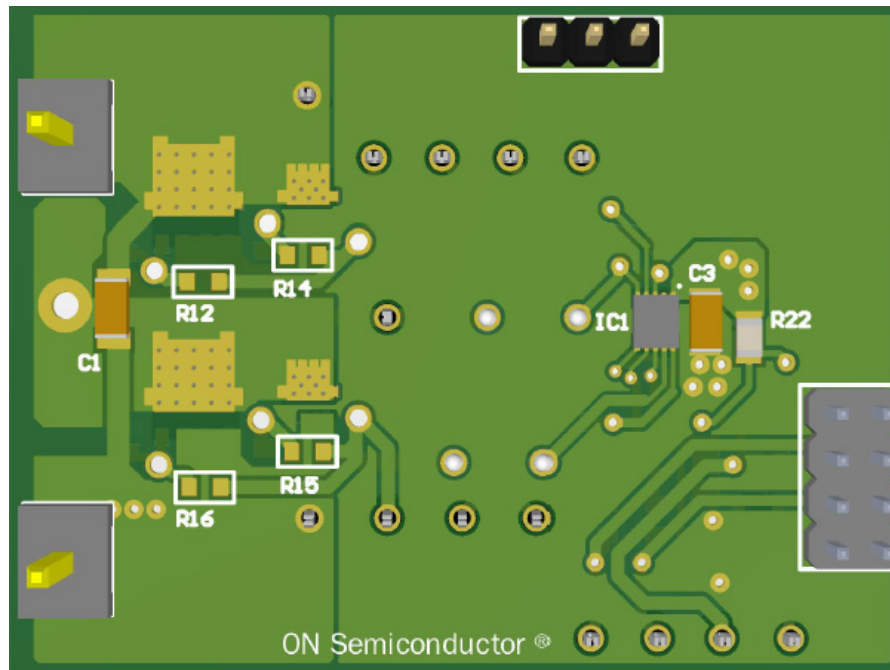

Figure 13. Board Bottom Side

EVBUM2703/D

BILL OF MATERIALS

Table 5. BILL OF MATERIALS

Qty	Designator	Manufacturer Part Number	Manufacturer	Description	Footprint
1	D2	NRVUA160VT3G	ON Semiconductor	Ultrafast power rectifier 600 V	SMA
2	D3, D4	BAT54T1G	ON Semiconductor	DIODE SCHOTTKY 30 V 200 mA SOD123	ONSC-SOD-123HE-2-425-04_V
2	D5, D6	SBAS16HT1G	On Semiconductor	Switching Diode, 2-Pin SOD-323, Pb-Free, Tape and Reel	ONSC-SOD-323-2-477-02_V
1	IC2	NCP51530BMNTWG	ON Semiconductor	High and Low side gate driver 700 V 3.5/3 A	DFN10 4x4
2	Q1, Q2	NVTFS5C453NLWFTAG	ON Semiconductor	Single, N-Channel, 40 V, 3.1 m Ω , 107 A	WDFN8 3.3x3.3
2	Q3, Q4	NVMFS6H800NLT1G	ON Semiconductor	Single, N-Channel, 80 V, 1.9 m Ω , 224 A	ONSC-DFN-5-488AA_V
1	C1	C1206C104K2RACTU	KEMET	Capacitor, C Series, 0.1 μ F, 10%, X7R, 200 V, 1206 [3216 Metric]	1206
2	C2, C3	C1206C225K5RAC	KEMET	Cap Ceramic 2.2 μ F 50 V X7R 10% SMD 1206 125°C Bulk	1206
1	C4	C0805C104J5RACTU	Kemet	CAP CER 100 nF 50 V X7R 0805	0805
2	C5, C6	C0805C222J5RACTU	KEMET	MLCC - SMD/SMT 50 V 2.2 nF X7R 5%	0805
1	C7	CC0805KKX7R8BB225	Yageo	CAP CER 2.2 μ F 25 V 0805	0805
2	J1, J2	1430-1	Keystone Electronics	Jumper TH 5.08 mm	Jumper 5.08 mm
10	R1, R10, R12, R14, R15, R16, R17, R18, R19, R20	CRCW06030000Z0EB	Vishay Dale	Res Thick Film 0603 0 Ω Molded SMD Automotive Paper T/R	0603
2	R11, R13	CRCW080556R0FKEA	Vishay	Res Thick Film 0805 56 Ω 1% 1/8 W \pm 100 ppm/ $^{\circ}$ C Molded SMD SMD Paper T/R	0805
3	R2, R3, R21	SMM02040C2008FB300	Vishay	Res Thin Film 0204(1406) 2 Ω 1% 1/4 W \pm 50 ppm/ $^{\circ}$ C Conformal Melf SMD Blister T/R	0204
1	R22	ERJ-6ENF1002V	Panasonic	Res Thick Film 0805 10 k Ω 1% 1/8 W \pm 100 ppm/ $^{\circ}$ C Molded SMD Punched Carrier T/R	0805
2	R4, R8	CRCW08056R80JNEA	Vishay Dale	RES SMD 6.8 Ω 5% 1/8 W 0805	0805
4	R5, R6, R9, R23	CRCW080522K0JNEAIF	Vishay	Res Thick Film 0805 22 k Ω 5% 1/8 W \pm 200 ppm/ $^{\circ}$ C Molded SMD Paper T/R	0805
14	TP1, TP2, TP3, TP4, TP5, TP6, TP7, TP8, TP9, TP10, TP11, TP12, TP13, TP14	5001	Keystone Electronics	TH Test point (2.54 mm dia)	TH Test point
1	X1	61300311121	Würth Electronics	Header 3x1 2.54 mm	3x1 male header PCB connector
2	X20, X21	FWS-01-01-T-S	Samtec	1x1 male pin header. 19 mm overall length. 11 mm contact length	1x1 pin header
1	X4	61300821121	Würth Electronics	Conn header 4x2 2.54 mm	4x2 PCB connector

onsemi, **Onsemi**, and other names, marks, and brands are registered and/or common law trademarks of Semiconductor Components Industries, LLC dba "**onsemi**" or its affiliates and/or subsidiaries in the United States and/or other countries. **onsemi** owns the rights to a number of patents, trademarks, copyrights, trade secrets, and other intellectual property. A listing of **onsemi**'s product/patent coverage may be accessed at www.onsemi.com/site/pdf/Patent-Marking.pdf. **onsemi** is an Equal Opportunity/Affirmative Action Employer. This literature is subject to all applicable copyright laws and is not for resale in any manner.

The evaluation board/kit (research and development board/kit) (hereinafter the "board") is not a finished product and is not available for sale to consumers. The board is only intended for research, development, demonstration and evaluation purposes and will only be used in laboratory/development areas by persons with an engineering/technical training and familiar with the risks associated with handling electrical/mechanical components, systems and subsystems. This person assumes full responsibility/liability for proper and safe handling. Any other use, resale or redistribution for any other purpose is strictly prohibited.

THE BOARD IS PROVIDED BY ONSEMI TO YOU "AS IS" AND WITHOUT ANY REPRESENTATIONS OR WARRANTIES WHATSOEVER. WITHOUT LIMITING THE FOREGOING, ONSEMI (AND ITS LICENSORS/SUPPLIERS) HEREBY DISCLAIMS ANY AND ALL REPRESENTATIONS AND WARRANTIES IN RELATION TO THE BOARD, ANY MODIFICATIONS, OR THIS AGREEMENT, WHETHER EXPRESS, IMPLIED, STATUTORY OR OTHERWISE, INCLUDING WITHOUT LIMITATION ANY AND ALL REPRESENTATIONS AND WARRANTIES OF MERCHANTABILITY, FITNESS FOR A PARTICULAR PURPOSE, TITLE, NON-INFRINGEMENT, AND THOSE ARISING FROM A COURSE OF DEALING, TRADE USAGE, TRADE CUSTOM OR TRADE PRACTICE.

onsemi reserves the right to make changes without further notice to any board.

You are responsible for determining whether the board will be suitable for your intended use or application or will achieve your intended results. Prior to using or distributing any systems that have been evaluated, designed or tested using the board, you agree to test and validate your design to confirm the functionality for your application. Any technical, applications or design information or advice, quality characterization, reliability data or other services provided by **onsemi** shall not constitute any representation or warranty by **onsemi**, and no additional obligations or liabilities shall arise from **onsemi** having provided such information or services.

onsemi products including the boards are not designed, intended, or authorized for use in life support systems, or any FDA Class 3 medical devices or medical devices with a similar or equivalent classification in a foreign jurisdiction, or any devices intended for implantation in the human body. You agree to indemnify, defend and hold harmless **onsemi**, its directors, officers, employees, representatives, agents, subsidiaries, affiliates, distributors, and assigns, against any and all liabilities, losses, costs, damages, judgments, and expenses, arising out of any claim, demand, investigation, lawsuit, regulatory action or cause of action arising out of or associated with any unauthorized use, even if such claim alleges that **onsemi** was negligent regarding the design or manufacture of any products and/or the board.

This evaluation board/kit does not fall within the scope of the European Union directives regarding electromagnetic compatibility, restricted substances (RoHS), recycling (WEEE), FCC, CE or UL, and may not meet the technical requirements of these or other related directives.

FCC WARNING – This evaluation board/kit is intended for use for engineering development, demonstration, or evaluation purposes only and is not considered by **onsemi** to be a finished end product fit for general consumer use. It may generate, use, or radiate radio frequency energy and has not been tested for compliance with the limits of computing devices pursuant to part 15 of FCC rules, which are designed to provide reasonable protection against radio frequency interference. Operation of this equipment may cause interference with radio communications, in which case the user shall be responsible, at its expense, to take whatever measures may be required to correct this interference.

onsemi does not convey any license under its patent rights nor the rights of others.

LIMITATIONS OF LIABILITY: **onsemi** shall not be liable for any special, consequential, incidental, indirect or punitive damages, including, but not limited to the costs of requalification, delay, loss of profits or goodwill, arising out of or in connection with the board, even if **onsemi** is advised of the possibility of such damages. In no event shall **onsemi**'s aggregate liability from any obligation arising out of or in connection with the board, under any theory of liability, exceed the purchase price paid for the board, if any.

The board is provided to you subject to the license and other terms per **onsemi**'s standard terms and conditions of sale. For more information and documentation, please visit www.onsemi.com.

PUBLICATION ORDERING INFORMATION

LITERATURE FULFILLMENT:

Email Requests to: orderlit@onsemi.com

onsemi Website: www.onsemi.com

TECHNICAL SUPPORT

North American Technical Support:

Voice Mail: 1 800-282-9855 Toll Free USA/Canada

Phone: 011 421 33 790 2910

Europe, Middle East and Africa Technical Support:

Phone: 00421 33 790 2910

For additional information, please contact your local Sales Representative