

NCV840XXF Evaluation Board User's Manual

NCV840XXFEVB

The NCV840XXF Evaluation Board has been designed to enable a complete functional and parametric evaluation of the NCV840XXF single channel high-side driver. This evaluation board has been constructed to easily interface with different test systems and equipment through power terminals and test points located throughout the board. A variant of the evaluation board also has the option to integrate an Arduino Nano and use independent software routines to evaluate capabilities of the NCV840XXF device in a convenient user-friendly manner.

This document gives a detailed description of the NCV840XXF Evaluation Board (TSSOP-14 EP Package) with the bill of materials, board schematic, and a layout overview of the board. The document also provides details on operational aspects of the board and recommended external connections.

This document should be used with the NCV840XXF datasheet available on www.onsemi.com or the product preview provided with engineering samples. The evaluation board, in general, follows the application diagram, however the datasheet contains full technical details about the NCV840XXF specification, features, protections, diagnostics and other operations.

Features

- Power Terminals and Test Points for Drain and OUT Connections
- Test Points for all Logic Pins
- Protection Resistors on GND and Digital Inputs
- Optional Onboard 5 V Regulator
- Optional Connector to External Microcontroller
- Open Load Diagnosis Circuit
- Arduino Nano Integration
- Additional Demonstration Software

Typical Applications

- Power Distribution
- Switch Capacitive, Resistive, and Inductive Loads
- Automotive / Industrial

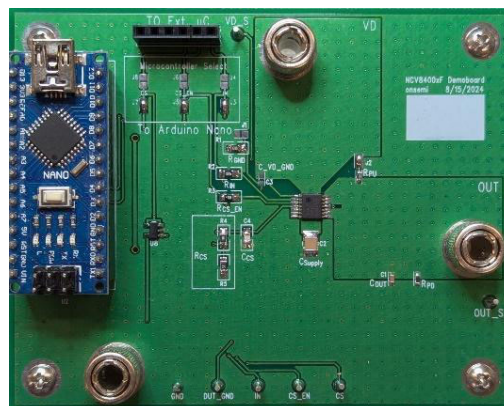

(Front Side)

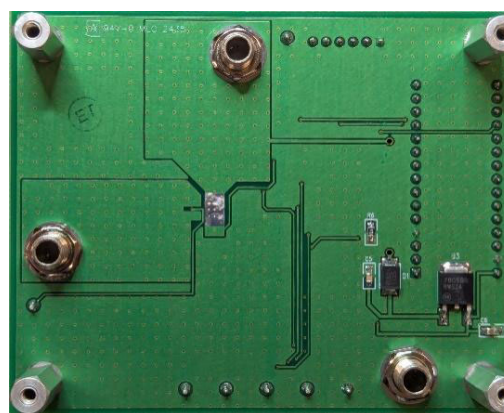

(Back Side)

Figure 1. Evaluation Board

ORDERING INFORMATION

Device
NCV840XXFNTGEVB
NCV840XXFTGEVB

XX represents IC version populated when ordering.

NCV840XXFEVB

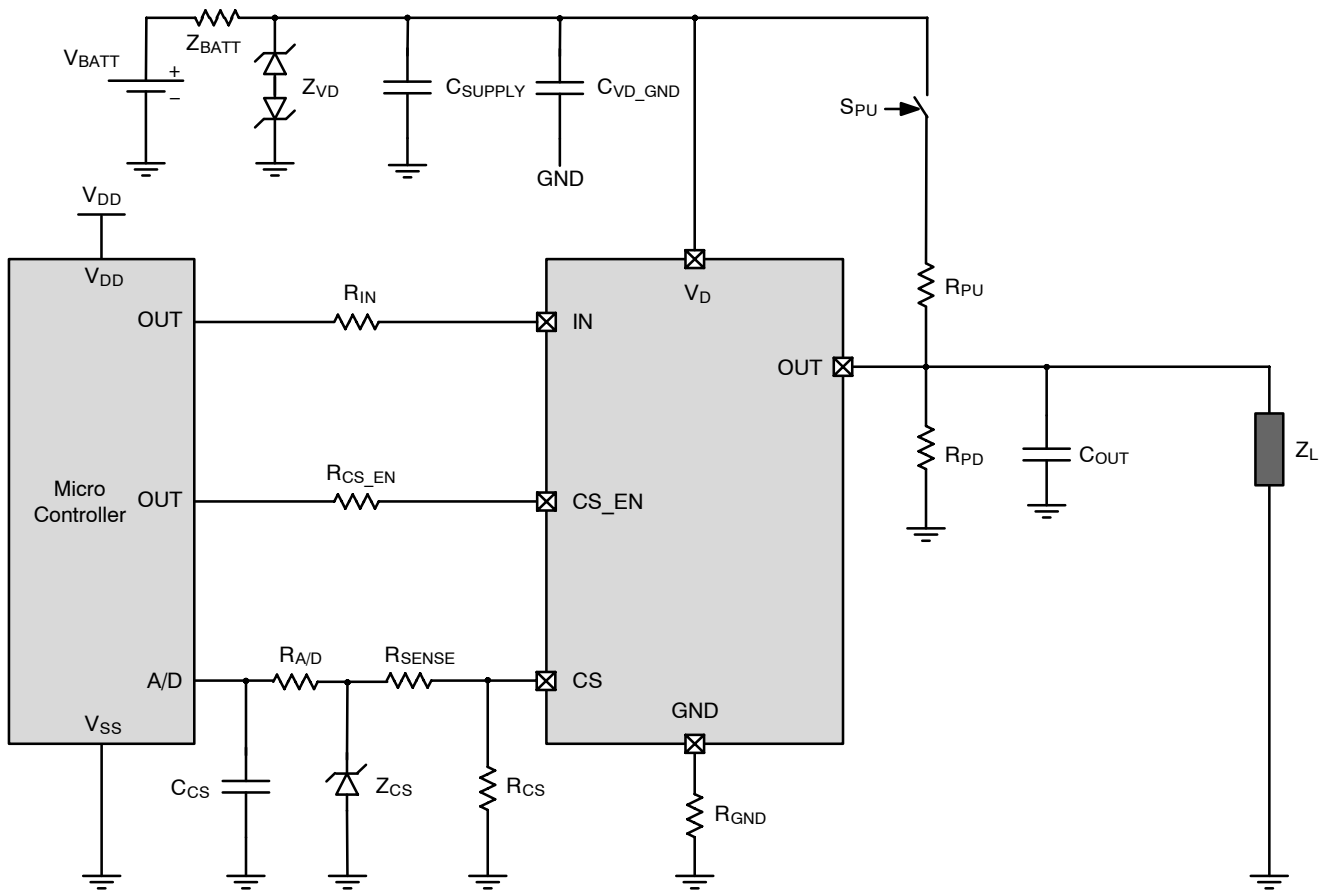

Figure 2. Recommended Application Diagram

Table 1. RECOMMENDED EXTERNAL COMPONENTS

Reference	Value	Description
R _{IN}	4.7 kΩ	Provides protection of the micro controller during overvoltage and reverse polarity. Ensures the channel is OFF during loss of GND.
R _{CS_EN}	4.7 kΩ	Provides protection of the micro controller during overvoltage and reverse polarity. Ensures the channel is OFF during loss of GND.
R _{CS}	1.2 kΩ	Current Sense resistor.
R _{SENSE}	4.7 kΩ	Provides protection against overvoltage, reverse polarity, and loss of GND. The value of this resistor should be selected with the micro controller specification.
C _{CS}	100 pF	Current Sense signal filtering.
R _{A/D}	4.7 kΩ	Current Sense signal filtering.
Z _{CS}	10 V Zener Diode	Provides protection micro controller during overvoltage at CS. Should be selected with the micro controller specification.
R _{PU}	1.5 kΩ	Polarizes the NCV840XXF output during OFF state open load diagnosis.
R _{PD}	47 kΩ	Output polarization. Improves the NCV840XXF immunity to electromagnetic noise and also used for short to V _{BATT} detection.
S _{PU}	BC807	Switches the battery voltage for OFF state open load diagnostic.
R _{GND}	47 Ω	Provides protection during over-voltage.
Z _{VD_Ext}	30 V Zener Diode	Provides protection of the device during overvoltage.
C _{SUPPLY}	100 nF	Filtering of voltage spikes on the battery line.
C _{V_D_GND}	47 nF	Provides drain voltage stability during fast transients such as overload.
C _{OUT}	10 nF	Protection during ESD and BCI on output.

NCV840XXFEVB

ELECTRICAL SPECIFICATIONS

Table 2. MAXIMUM RATINGS (Note 1)

Rating	Symbol	Min	Max	Unit
SUPPLY VOLTAGE				
Steady State Supply Voltage – NCV840XXFNTGEVB	V_D	6	18	V
Steady State Supply Voltage – NCV840XXFTGEVB		-0.3	18	
Max Supply Voltage for Transient Operations (Note 1)			28	V
CONNECTIONS TO DIGITAL INPUT PINS: IN, CS_EN				
Maximum Current Capability	$I_{TP_DIG_IN}$	$-I_{DIG_IN_MAX}$ (Note 2)	$I_{DIG_IN_MAX}$ (Note 2)	mA
Maximum Voltage Capability	$V_{TP_DIG_IN}$	-0.3	$V_{DIG_IN_MAX}$ (Note 2)	V
CONNECTIONS TO CURRENT SENSE OUTPUT				
Current at Current Sense Output	$I_{TP_CS_MAX}$	-25	$I_{CS_Fault_ILIM}$ (Note 2)	mA
Voltage at Current Sense Output	$V_{TP_CS_MAX}$	-0.3	V_D	V
OUTPUT CONNECTION				
Drain-Source Voltage at Power Transistor	V_{DS_MAX}		Z_{CL}	V
Max Output Current – Steady State	I_{OUT_MAX}		15 (Note 3)	A
Max Output Current – Transient	$I_{OUT_MAX_TRAN}$		I_{LIM}	A
CONNECTIONS TO DEVICE GROUND				
Current through GND Pin	I_{TP_GND}	$-I_{GND}$ (Note 2)	I_{GND} (Note 2)	mA
OPERATING TEMPERATURE				
Operating Ambient Temperature – NCV840XXFNTGEVB	T_{AMB}	-40	85 (Note 4)	°C
Operating Ambient Temperature – NCV840XXFTGEVB		-40	125	°C

Stresses exceeding those listed in the Maximum Ratings table may damage the device. If any of these limits are exceeded, device functionality should not be assumed, damage may occur and reliability may be affected.

1. For transient application only. Extended operation at absolute maximum voltage may affect device reliability.
2. Refer to product datasheet.
3. Limited by max rating of power terminal connector.
4. Limited by operation capability of Arduino-Nano.

NCV840XXFEVB

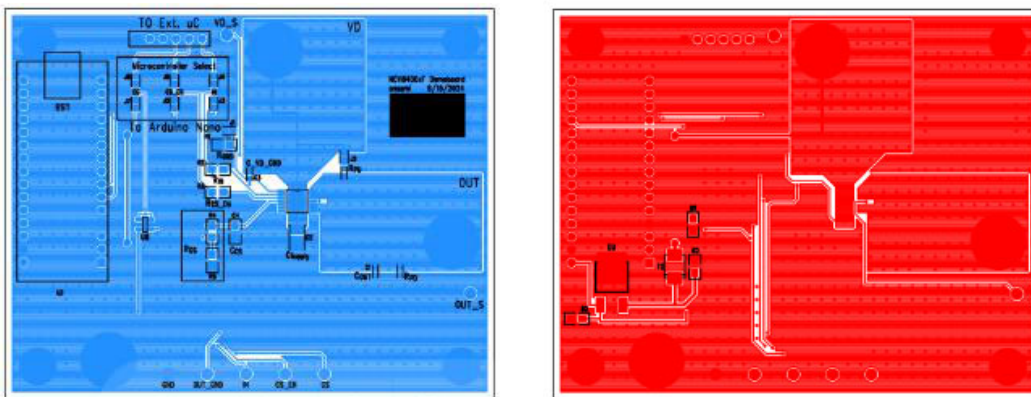

Figure 3. Board Layout (on Left) Top Layer, (on Right) Bottom Layer

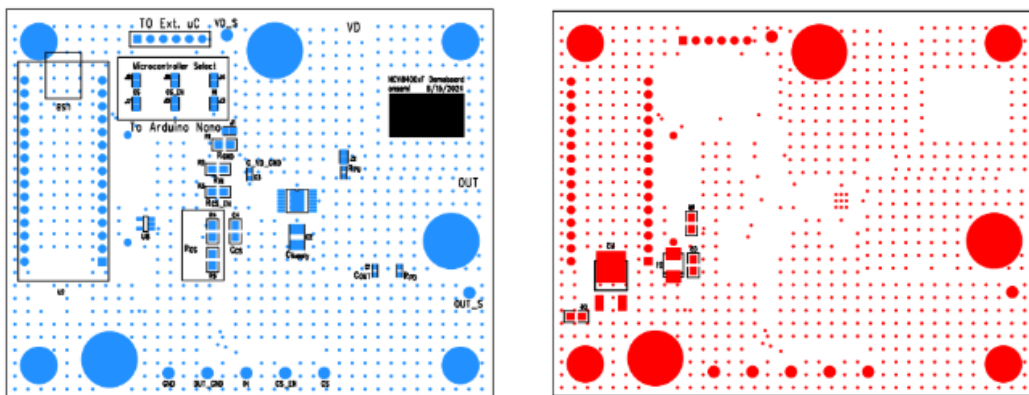

Figure 4. Board Layout without Traces (on Left) Top Layer, (on Right) Bottom Layer

Table 3. JUMPER DEFINITIONS

Jumper	Purpose	Default Connection
J1	To connect device GND pin to GND plane	NP
J2	To connect Pull Up resistor from OUT to VD for OSOL diagnosis	P
J3, J5, J7	To connect IN, CS_EN and CS respectively to Arduino Nano I/O	P: NCV840XXFNTGEVB NP: NCV840XXFTGEVB
J4, J6, J8	To connect IN, CS_EN and CS respectively to external microcontroller	NP

NCV840XXFEVB

Schematic

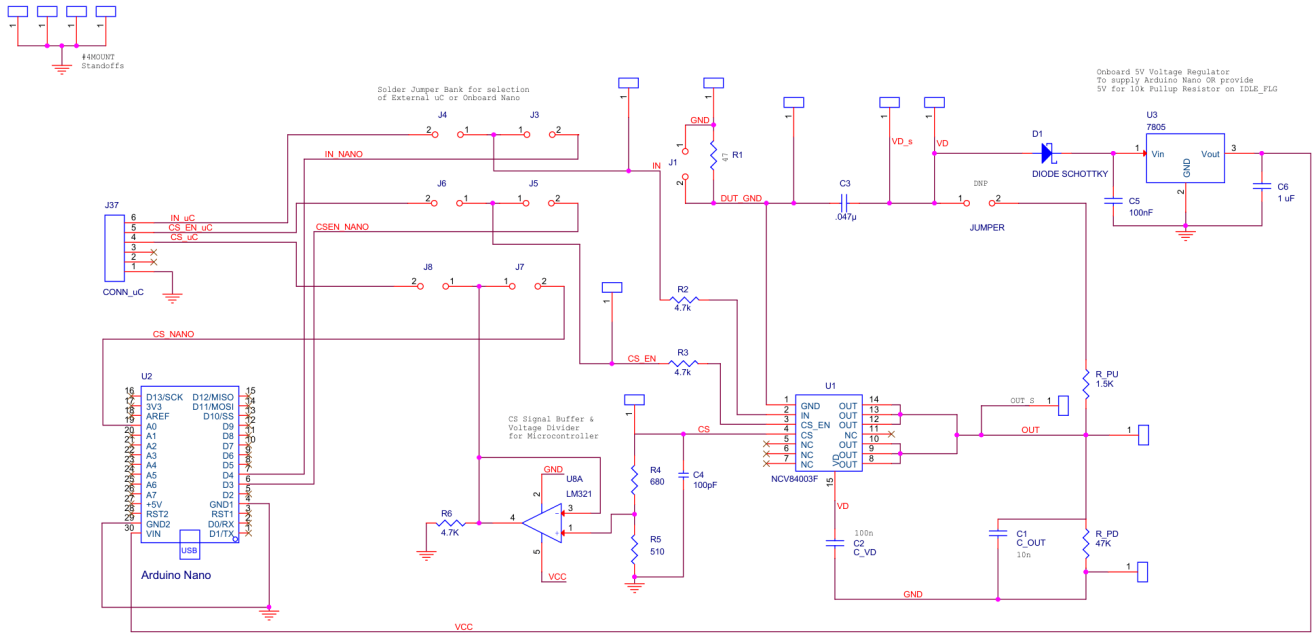

Figure 5. EVB Schematic

BOARD OPERATION

Supply

The EVB is required to be supplied via the connection VD as highlighted in Figure 6. This input serves as the supply (drain connection) for NCV840XXF as well as for other optional active circuits on the board including the regulator MC7805 that in turn powers an on-board voltage buffer and the Arduino nano. The board is designed to ensure that the performance of the device can be evaluated in the specified nominal operating voltage range. Further, transient operations such as jump start (and associated overcurrent limit), load dump etc. can also be evaluated on the board. At supply voltages lower than 6 V, the regulator can fail to provide sufficient output voltage for Arduino and the buffer. While evaluating for low voltage operations such as under-voltage shutdown and recovery times, it is therefore, recommended to use individual test points for driving logic inputs (Refer [Digital Inputs](#) section). It should be noted that the buffer output will not be available at low battery voltages. The drain pin on the device is connected to filter capacitor and an optional capacitor to device GND (as specified per [BOM](#)) for eliminating any unexpected fast transients that may affect device response.

Output

The output terminal can be connected to the desired load per application. While connecting to the output, the cable length and impedance should be noted as it may impact the protection mechanisms such as peak current levels observed in overcurrent detection, or the current slew off time after an over-load detection. The board can also be used to switch inductive loads within the maximum rated capability of the device. It should also be noted that the maximum steady state output current is limited by the capability of the power connectors and is specified in the electrical characteristics of this reference document. The test point can be used to monitor voltage at this node using DC multimeters/oscilloscope. As with supply connection, output has a filter capacitor populated on board (as specified per [BOM](#)) to eliminate high frequency noise. Further, referring to Figure 6, the output node is connected to VD through a pull-up resistance R_{PU} and to GND through a pull-down resistor R_{PD} (as specified per [BOM](#)) to diagnose off-state open load and short circuit to battery respectively (Refer to product datasheet for details).

Ground Network

The device needs to be always supplied with a ground connection for it to function as desired. The device response in case of a loss of device or load GND condition is

explained in the product datasheet. The evaluation board has a protection resistor connected to the ground pin to protect and limit the current across the internal ESD's and clamps in case of transient over-voltage events. The test point at GND pin can be used to monitor the ground potential, or to measure the ground current.

Digital Inputs

The digital inputs (IN and CS_EN) are provided with the option to be driven externally via individual test points or using a plug-in connector to an external microcontroller. Further, there is an optional socket (only on NCV840XXFNTGEVB version) to plug in an on-board Arduino that can drive the digital inputs using the provided software. The user can also load the Arduino with their own software routines to drive the pins as they desire in the application or to observe mode transitions as specified in product datasheet. It should be noted that if evaluation at high ambient temperatures is desired then external test points on NCV840XXFTGEVB should be connected to wires that can withstand temperature. When using an external test point, a 3.3 V/5 V compatible logic input can be interfaced to these pins. Jumpers J3–J4 and J5–J6 can be used to connect on-board Arduino or external microcontroller to IN and CS_EN respectively (Refer Table 3 for details). The digital inputs are interfaced to the device with series protection resistors that limit the current through logic ESD's in case of transient over-voltage events.

Current Sense Output

The current sense output is connected to a network of resistors and a filter capacitor (values per the [BOM](#) specified). The output voltage on the resistor network can be measured directly on the dedicated test point (Refer Figure 6), or the jumpers J7–J8 can be used to route this signal to on-board Arduino/external microcontroller connector (as explained in Table 3). The current sense output going to this jumper bank is attenuated via the potential divider at the CS pin. This is done to protect the Arduino/micro inputs from getting damaged at high CS output voltages. In addition, the EVB also consists of a buffer (LM321) to prevent CS pin loading before connecting it to Arduino input. While monitoring the CS output voltage for load current estimation/diagnosis, the required CS operation voltage and normal/fault CS output current levels must be considered as specified per the product datasheet. Further, when processing/digitizing CS voltage through Arduino or microcontroller, the on-board attenuation must be accounted for as explained in [Operational Guidelines](#).

NCV840XXFEVB

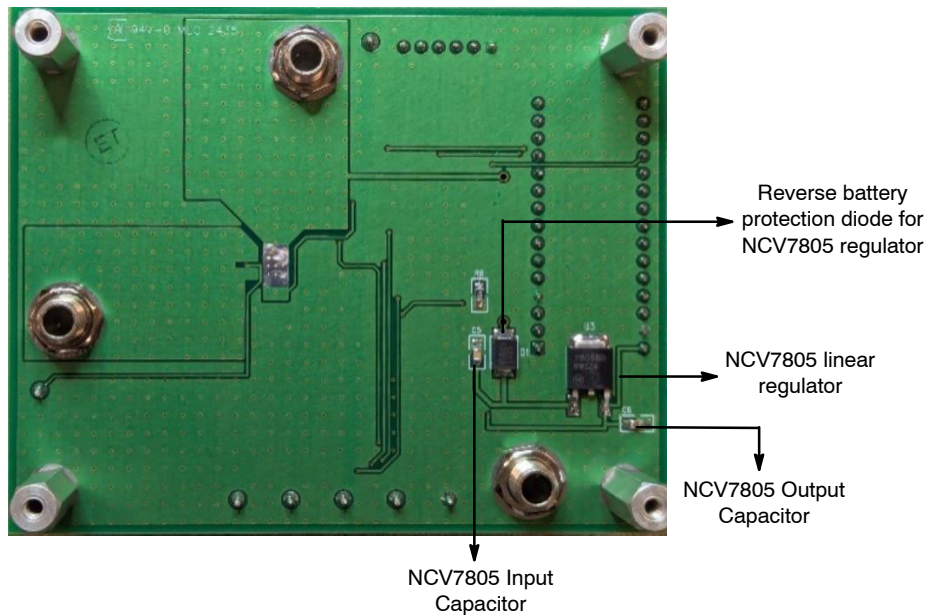
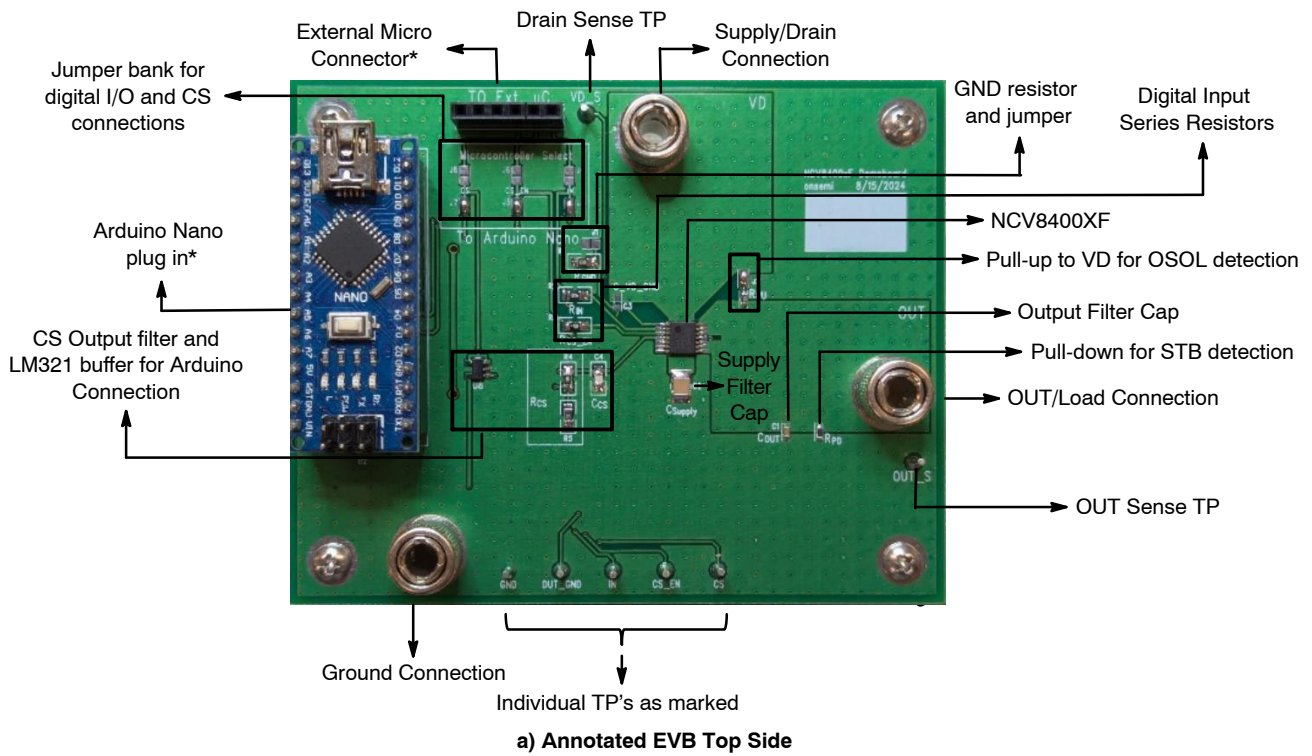

b) Annotated EVB Bottom Side

Figure 6. Annotated EVB

NCV840XXFEVB

OPERATIONAL GUIDELINES

The test procedure below will demonstrate the general functionality of the NCV840XXF evaluation boards:

1. Connect a DC input voltage at VD connector within the recommended operating limits as specified. The power supply should be capable of handling the load inrush and steady state power requirements. If required, external bulk capacitors can be connected to the power supply. DO NOT switch on power in this step.
2. Connect the desired load per application to the OUT connector.
3. Configure the digital input driving connections to either on-board Arduino or use the external microcontroller connector interface (on NCV840XXFNTGEVB). Alternatively, individual test points can also be connected (on NCV840XXFTGEVB) to external pulse signal generators/DC power supplies compatible with CMOS logic levels. The voltage and temperature

$$V_{CS_Attn} = (R5 / (R4 + R5)) \times V_{CS} = (510 / (510 + 680)) \times V_{CS} = 0.428 \times V_{CS} \text{ (values per specified BOM)} \quad (\text{eq. 1})$$

So, for a maximum current sense output current of 10 mA (Refer to $I_{CS_Fault_ILIM}$ and I_{CS_SAT} specifications per datasheet), V_{CS} input going into LM321 can be calculated as: $V_{CS_Attn} = 0.428 \times 10 \text{ mA} \times 1190 \Omega = 5.1 \text{ V}$. This signal

limitations of these alternatives have been presented in the sections above.

4. While using Arduino, the provided software code can be used, or the user can program the Arduino as desired.
5. The oscilloscope probes, if desired, can be connected to the test points to monitor signal transitions.
6. It is recommended to apply the pulsed sequence on digital inputs (if using one) and observing the same on oscilloscope for verification before switching on the power supply at VD. This ensures that the applied pulse duration, signal sequence, PWM/duty cycle (if required) etc. on IN and CS_EN is as desired by the user.
7. Finally, the power supply can be switched on and user can observe/monitor output voltage, load current, current sense output and other signals as desired.

The current sense signal as an input to LM321 buffer is voltage-divided per the equation below:

attenuation protects the Arduino/microcontroller input from high voltage levels and must be accounted for while doing digitization/processing of the current sense signal using Arduino or external microcontroller.



NCV840XXFEVB

EVALUATION BOARD GRAPHICAL USER INTERFACE

A User Interface and Arduino sketch are paired with the evaluation board.

The GUI will be disabled until a connection to the Arduino is established. To connect:

1. Refresh the COM ports with the 'Refresh COM Ports' button.
2. Select the correct COM port with the dropdown.
3. Click 'Connect to Arduino'.

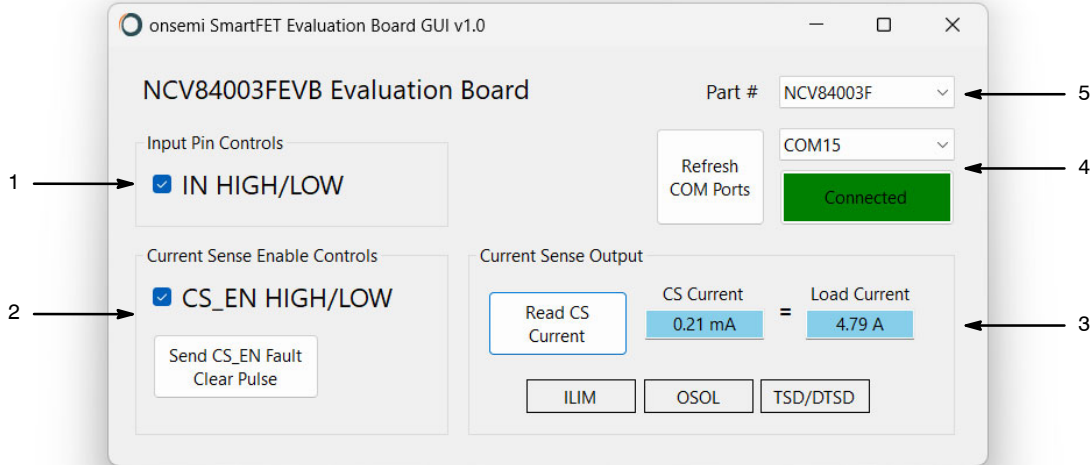

Figure 7. Evaluation Board GUI Usage

1. *Input Pin Controls*: Check/uncheck the box to control the IN pin. The startup mode will be highlighted depending on the state of the CS_EN pin.
2. *Current Sense Enable Controls*: Check/uncheck the box to control the CS_EN pin. If the IN pin is HIGH, the GUI will allow a Fault Clear Pulse via the CS_EN pin. A Status Readback or Configuration Readback Pulse will be available depending on the state of the IN pin.
3. *Current Sense Output*: The output of the CS pin is displayed in this section. If the CS_EN pin is high,

- the GUI will enable the 'Read CS Current' button. If a fault is flagged on the CS Pin, one of the fault indicators will turn red. If a Config Readback Pulse is sent, the resistor settings will be updated here.
4. *Arduino COM Port Controls*: The 'Connect to Arduino' button will change to 'Connected' or 'Disconnected' if the status of the Arduino serial connection is changed. Click the button to change the status.
5. *Part Number Dropdown*: This dropdown will change the CS Ratio used in the 'Current Sense Output' section.

NCV840XXFEVB

BILL OF MATERIALS (BOM)

Table 4. BILL OF MATERIALS FOR THE NCV840XXFNTGEVB

Designator (Main Board)	Quantity	Description	Value	Tolerance	Footprint	Manufacturer	Manufacturer Part Number	Subst. Allowed	Lead Free
Rpu	1	1.5 kOhms ±1% 0.125W, 1/8W Chip Resistor 0603	1.5 kOhms	±1%	0603	Stackpole Electronics	RNCP0603TFD1K50	Yes	Yes
Rpd	1	47 kOhms ±1% 0.125W, 1/8W Chip Resistor 0603	47 kOhms	±1%	0603	Panasonic	ERJ-H3EF4702V	Yes	Yes
R4	1	RES SMD 680 OHM 5% 1/8W 0805	680 Ohms	±5%	0805	Panasonic	ERJ-6GEYJ681V	Yes	Yes
R5	1	RES 510 OHM 5% 1/8W 0805	510 Ohms	±5%	0805	Stackpole Electronics	RMCF0805JT510R	Yes	Yes
R2, R3, R6	3	4.7 kOhms ±1% 0.125W, 1/8W Chip Resistor 0805	4.7 kOhms	±1%	0805	Yageo	RC0805FR-074K7L	Yes	Yes
R1 (Rgnd)	1	47 Ohms ±1% 0.125W, 1/8W Chip Resistor 0805	47 Ohms	±1%	0805	Stackpole Electronics	RMCF0805FT47R0	Yes	Yes
J1, J4, J6, J8	DNP	0 Ohms Jumper Chip Resistor 0603	0 Ohms	±5%	0603	Stackpole Electronics	RMCF0603ZT0R00	Yes	Yes
J2, J3, J5, J7	4	0 Ohms Jumper Chip Resistor 0603	0 Ohms	±5%	0603	Stackpole Electronics	RMCF0603ZT0R00	Yes	Yes
C2 (Csupply)	1	100nF ±10% 50V Ceramic Capacitor X5R 1210	100 nF	±10%	1210	KEMET	C1210C104K5RACTU	Yes	Yes
C4 (Ccs)	1	100pF ±5% 50V Ceramic Capacitor X7R 0805	100 pF	±5%	0805	Yageo	CC0603JRNPO9BN101	Yes	Yes
C3 (C_VD_GND)	1	47nF ±10% 50V Ceramic Capacitor X7R 0603	47 nF	±10%	0603	Walsin Technology	0603B473K500CT	Yes	Yes
C1 (Cout)	1	10nF 50V Ceramic Cap 0603	10 nF	±5%	0603	KEMET	C0603C103J5RACTU	Yes	Yes
C6	1	1uF 50V Ceramic Cap 0805	1 uF	±10%	0805	Samsung Electro-Mechanics	CL21B105KBFNNNE	Yes	Yes
C5	1	330nF 50V Ceramic Cap 0805	330 nF	±10%	0805	TDK Corporation	CGA4J2X7R1H334K125DA	Yes	Yes
U3	1	Linear Voltage Regulator IC Positive Fixed 1 Output 1A DPAK	Linear Voltage Regulator	N/A	DPAK3_SMD	onsemi	MC7805BDTG	No	Yes
D1	1	Diode Schottky 50V 2A Surface Mount DO-214AA (SMB)	50V, 2A	N/A	SMB_DIODE	onsemi	SS25	No	Yes
U8	1	IC OPAMP GP 1 CIRCUIT 5TSOP	GP OP AMP	N/A	TSOP-5	onsemi	LM321SN3T1G	No	Yes
U1	1	Self-Protected Very Low IQ High Side Driver with Analog Current Sense	N/A	N/A	TSSOP 14EP	onsemi	NCV840XXFPAR2G	No	Yes
VD, OUT, GND	3	CONN BIND POST KNURLED	Connector Header Connector	N/A	BANANA	Cinch Connectivity Solutions	111-2223-001	Yes	Yes
U2 (Arduino and Headers)	2	CONN HDR 15POS 0.1 TIN PCB	Connector Header Connector	N/A	ARDUINON ANO	Sullins Connector Solutions	PPTC151LFBN-RC	Yes	Yes
	1	Arduino Nano Every Microcontroller	ucontroller	N/A		Arduino	ABX00028	No	Yes
	1	CBL USB2.0 A PLUG-MIN A PLUG 6"	N/A	N/A		Stewart Connector	SC-2ANK006F	Yes	Yes
J37 ("TO Ext. uC" 6 pos Header)	1	CONN HDR 6POS 0.1 TIN PCB	Connector Header Connector	N/A	JP6	Sullins Connector Solutions	PPTC061LFBN-RC	Yes	Yes
(Board Standoffs) TP84, TP85, TP86, TP87	4	HEX STANDOFF #4-40 ALUMINUM 3/4"	N/A	N/A	#4MOUNT	Keystone Electronics	2204	Yes	Yes
	4	Machine Screw Pan Phillips #4-40 x 1/4"	N/A	N/A			9900	Yes	Yes
GND, IN, CS_EN, CS, DUT_GND, OUT_S, VD_S	7	Test Point	N/A	N/A	TP	Vector Electronics	K31C/M	Yes	Yes

NCV840XXFEVB

Table 5. BILL OF MATERIALS FOR THE NCV840XXFTGEVB

Designator (Main Board)	Quantity	Description	Value	Tolerance	Footprint	Manufacturer	Manufacturer Part Number	Subst. Allowed	Lead Free
Rpu	1	1.5 kOhms ±1% 0.125W, 1/8W Chip Resistor 0603	1.5 kOhms	±1%	0603	Stackpole Electronics	RNCP0603TFD1K50	Yes	Yes
Rpd	1	47 kOhms ±1% 0.125W, 1/8W Chip Resistor 0603	47 kOhms	±1%	0603	Panasonic	ERJ-H3EF4702V	Yes	Yes
R4	1	RES SMD 680 OHM 5% 1/8W 0805	680 Ohms	±5%	0805	Panasonic	ERJ-6GEYJ681V	Yes	Yes
R5	1	RES 510 OHM 5% 1/8W 0805	510 Ohms	±5%	0805	Stackpole Electronics	RMCF0805JT510R	Yes	Yes
R2, R3, R6	3	4.7 kOhms ±1% 0.125W, 1/8W Chip Resistor 0805	4.7 kOhms	±1%	0805	Yageo	RC0805FR-074K7L	Yes	Yes
R1 (Rgnd)	1	47 Ohms ±1% 0.125W, 1/8W Chip Resistor 0805	47 Ohms	±1%	0805	Stackpole Electronics	RMCF0805FT47R0	Yes	Yes
J1, J3, J4, J5, J6, J7, J8	DNP	0 Ohms Jumper Chip Resistor 0603	0 Ohms	±5%	0603	Stackpole Electronics	RMCF0603ZT0R00	Yes	Yes
J2	1	0 Ohms Jumper Chip Resistor 0603	0 Ohms	±5%	0603	Stackpole Electronics	RMCF0603ZT0R00	Yes	Yes
C2 (Csupply)	1	100nF ±10% 50V Ceramic Capacitor X5R 1210	100 nF	±10%	1210	KEMET	C1210C104K5RACTU	Yes	Yes
C4 (Ccs)	1	100pF ±5% 50V Ceramic Capacitor X7R 0805	100 pF	±5%	0805	Yageo	CC0603JRNPO9BN101	Yes	Yes
C3 (C_VD_GND)	1	47nF ±10% 50V Ceramic Capacitor X7R 0603	47 nF	±10%	0603	Walsin Technology	0603B473K500CT	Yes	Yes
C1 (Cout)	1	10nF 50V Ceramic Cap 0603	10 nF	±5%	0603	KEMET	C0603C103J5RACTU	Yes	Yes
C6	1	1uF 50V Ceramic Cap 0805	1 uF	±10%	0805	Samsung Electro-Mechanics	CL21B105KBFNNNE	Yes	Yes
C5	1	330nF 50V Ceramic Cap 0805	330 nF	±10%	0805	TDK Corporation	CGA4J2X7R1H334K125DA	Yes	Yes
U3	1	Linear Voltage Regulator IC Positive Fixed 1 Output 1A DPAK	Linear Voltage Regulator	N/A	DPAK3_SMD	onsemi	MC7805BDTG	No	Yes
D1	1	Diode Schottky 50V 2A Surface Mount DO-214AA (SMB)	50V, 2A	N/A	SMB_DIODE	onsemi	SS25	No	Yes
U8	1	IC OPAMP GP 1 CIRCUIT 5TSOP	GP OP AMP	N/A	TSOP-5	onsemi	LM321SN3T1G	No	Yes
U1	1	Self-Protected Very Low IQ High Side Driver with Analog Current Sense	N/A	N/A	TSSOP14EP	onsemi	NCV840XXFPAR2G	No	Yes
VD, OUT, GND	3	CONN BIND POST KNURLED	Connector Header Connector	N/A	BANANA	Cinch Connectivity Solutions	111-2223-001	Yes	Yes
U2 (Arduino and Headers)	DNP	CONN HDR 15POS 0.1 TIN PCB	Connector Header Connector	N/A	ARDUINONA NO	Sullins Connector Solutions	PPTC151LFBN-RC	Yes	Yes
	DNP	Arduino Nano Every Microcontroller	ucontroller	N/A		Arduino	ABX00028	No	Yes
	DNP	CBL USB2.0 A PLUG-MIN A PLUG 6'	N/A	N/A		Stewart Connector	SC-2ANK006F	Yes	Yes
J37 ("TO Ext. uC" 6 pos Header)	DNP	CONN HDR 6POS 0.1 TIN PCB	Connector Header Connector	N/A	JP6	Sullins Connector Solutions	PPTC061LFBN-RC	Yes	Yes
(Board Standoffs) TP84, TP85, TP86, TP87	4	HEX STANDOFF #4-40 ALUMINUM 3/4"	N/A	N/A	#4MOUNT	Keystone Electronics	2204	Yes	Yes
	4	Machine Screw Pan Phillips #4-40 x 1/4"					9900	Yes	Yes
GND, IN, CS_EN, CS, DUT_GND, OUT_S, VD_S	7	Test Point	N/A	N/A	TP	Vector Electronics	K31C/M	Yes	Yes

NCV840XXFEVB

REVISION HISTORY

Revision	Description of Changes	Date
0	Initial document release.	4/28/2026
1	Edit orderable part numbers throughout document, one value edit table 1, text edits board operation section, replace tables 4 and 5	6/10/2026

onsemi, **Onsemi**, and other names, marks, and brands are registered and/or common law trademarks of Semiconductor Components Industries, LLC dba "**onsemi**" or its affiliates and/or subsidiaries in the United States and/or other countries. **onsemi** owns the rights to a number of patents, trademarks, copyrights, trade secrets, and other intellectual property. A listing of **onsemi**'s product/patent coverage may be accessed at www.onsemi.com/site/pdf/Patent-Marking.pdf. **onsemi** is an Equal Opportunity/Affirmative Action Employer. This literature is subject to all applicable copyright laws and is not for resale in any manner.

The evaluation board/kit (research and development board/kit) (hereinafter the "board") is not a finished product and is not available for sale to consumers. The board is only intended for research, development, demonstration and evaluation purposes and will only be used in laboratory/development areas by persons with an engineering/technical training and familiar with the risks associated with handling electrical/mechanical components, systems and subsystems. This person assumes full responsibility/liability for proper and safe handling. Any other use, resale or redistribution for any other purpose is strictly prohibited.

THE BOARD IS PROVIDED BY ONSEMI TO YOU "AS IS" AND WITHOUT ANY REPRESENTATIONS OR WARRANTIES WHATSOEVER. WITHOUT LIMITING THE FOREGOING, ONSEMI (AND ITS LICENSORS/SUPPLIERS) HEREBY DISCLAIMS ANY AND ALL REPRESENTATIONS AND WARRANTIES IN RELATION TO THE BOARD, ANY MODIFICATIONS, OR THIS AGREEMENT, WHETHER EXPRESS, IMPLIED, STATUTORY OR OTHERWISE, INCLUDING WITHOUT LIMITATION ANY AND ALL REPRESENTATIONS AND WARRANTIES OF MERCHANTABILITY, FITNESS FOR A PARTICULAR PURPOSE, TITLE, NON-INFRINGEMENT, AND THOSE ARISING FROM A COURSE OF DEALING, TRADE USAGE, TRADE CUSTOM OR TRADE PRACTICE.

onsemi reserves the right to make changes without further notice to any board.

You are responsible for determining whether the board will be suitable for your intended use or application or will achieve your intended results. Prior to using or distributing any systems that have been evaluated, designed or tested using the board, you agree to test and validate your design to confirm the functionality for your application. Any technical, applications or design information or advice, quality characterization, reliability data or other services provided by **onsemi** shall not constitute any representation or warranty by **onsemi**, and no additional obligations or liabilities shall arise from **onsemi** having provided such information or services.

onsemi products including the boards are not designed, intended, or authorized for use in life support systems, or any FDA Class 3 medical devices or medical devices with a similar or equivalent classification in a foreign jurisdiction, or any devices intended for implantation in the human body. You agree to indemnify, defend and hold harmless **onsemi**, its directors, officers, employees, representatives, agents, subsidiaries, affiliates, distributors, and assigns, against any and all liabilities, losses, costs, damages, judgments, and expenses, arising out of any claim, demand, investigation, lawsuit, regulatory action or cause of action arising out of or associated with any unauthorized use, even if such claim alleges that **onsemi** was negligent regarding the design or manufacture of any products and/or the board.

This evaluation board/kit does not fall within the scope of the European Union directives regarding electromagnetic compatibility, restricted substances (RoHS), recycling (WEEE), FCC, CE or UL, and may not meet the technical requirements of these or other related directives.

FCC WARNING – This evaluation board/kit is intended for use for engineering development, demonstration, or evaluation purposes only and is not considered by **onsemi** to be a finished end product fit for general consumer use. It may generate, use, or radiate radio frequency energy and has not been tested for compliance with the limits of computing devices pursuant to part 15 of FCC rules, which are designed to provide reasonable protection against radio frequency interference. Operation of this equipment may cause interference with radio communications, in which case the user shall be responsible, at its expense, to take whatever measures may be required to correct this interference.

onsemi does not convey any license under its patent rights nor the rights of others.

LIMITATIONS OF LIABILITY: **onsemi** shall not be liable for any special, consequential, incidental, indirect or punitive damages, including, but not limited to the costs of requalification, delay, loss of profits or goodwill, arising out of or in connection with the board, even if **onsemi** is advised of the possibility of such damages. In no event shall **onsemi**'s aggregate liability from any obligation arising out of or in connection with the board, under any theory of liability, exceed the purchase price paid for the board, if any.

The board is provided to you subject to the license and other terms per **onsemi**'s standard terms and conditions of sale. For more information and documentation, please visit www.onsemi.com.

ADDITIONAL INFORMATION

TECHNICAL PUBLICATIONS:

Technical Library: www.onsemi.com/design/resources/technical-documentation
onsemi Website: www.onsemi.com

ONLINE SUPPORT: www.onsemi.com/support

For additional information, please contact your local Sales Representative at www.onsemi.com/support/sales