

FAN4910x TinyPower™ Buck Boost Regulator Evaluation Board User's Manual

EVBUM2955/D

DESCRIPTION

The FAN4910X evaluation board is a compact circuit for evaluating onsemi's FAN4910X family of Buck-Boost regulators in a 20-bump Wafer-Level Chip-Scale Package (WLCSP).

The FAN49101 and FAN49103 IC versions include a programmable I²C interface and the FAN49100 version is a stand-alone IC with MODE (forced PWM or Auto Mode) and PT (forced pass-thru) feature pins. Please visit onsemi's website at <https://www.onsemi.com> for additional details on these products.

The board also features footprints to accommodate additional input/output capacitors and probe access points to all key circuit nodes so that electrical characteristics can be measured.

Features

- Input Voltage Range: 2.5 V to 5.5 V
- Programmable Output Voltage (I²C Compatible Versions only):
 - ◆ 2.5 to 2.8 V in 0.05 V Steps
 - ◆ 2.8 to 4.0 in 0.025 V Steps
- 1.8 MHz Fixed-Frequency Operation in PWM Mode
- Seamless Step-up and Step-down Mode Transitions
- Low Quiescent Current
- Internal Soft-Start
- Optional Output Discharge

- Low Ripple
- Excellent Transient Response
- Safety Protections (UVLO, OTP, SCP, OCP)
- Package: 20 Bump, 0.4 mm pitch WLCSP

Quick Start Connection Guide

1. Connect input power supply (3.6 V typical with 2.5 V–5.5 V range) between banana jacks VIN and GND as shown in Figure 1 (labeled Input).
2. FAN49101 & FAN49103 Versions: Remove jumper from the EN header to enable/disable the IC from the GUI. Or set EN to (–) when operating the IC in standalone mode (without the GUI). FAN49100 Versions: Set the EN header to (–) and set the PT and MODE pins to the desired position. Go to Step 5.
3. FAN49101 & FAN49103 Versions: Connect the USB Interface POD as shown in Figure 6.
4. FAN49101 & FAN49103 Versions: Start up the GUI application. If not installed, refer to section *Installation*.
5. Connect the external load between banana jacks VOUT and GND as shown in Figure 1 (labeled Load).
6. Set EN to (+) to enable the IC in Softstart.

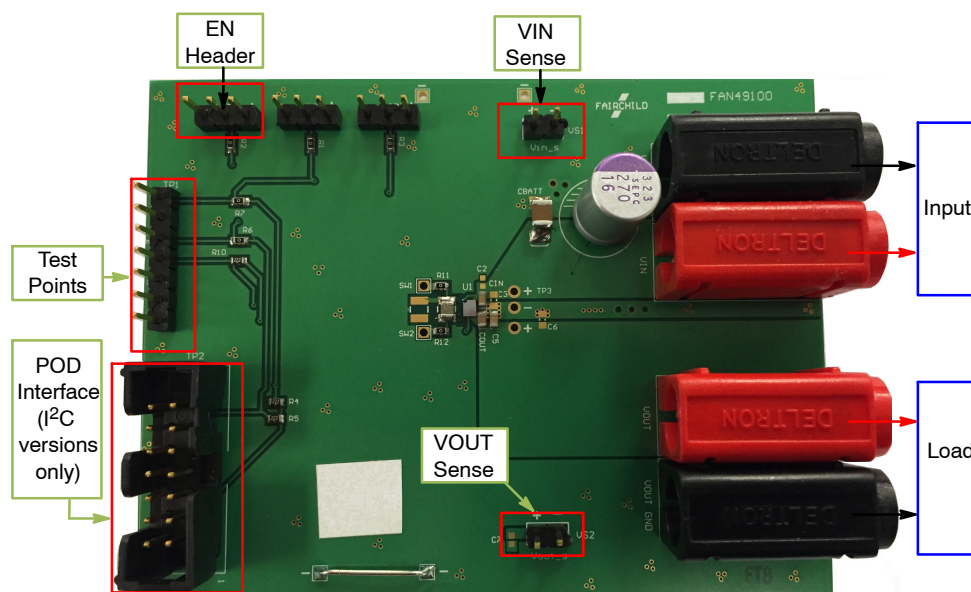

Figure 1. Evaluation Board Connection Diagram

GUI INSTALLATION

Installation

- a. Run the installer_FAN49103.exe .
- b. Follow the steps as shown in dialog box for the setup.

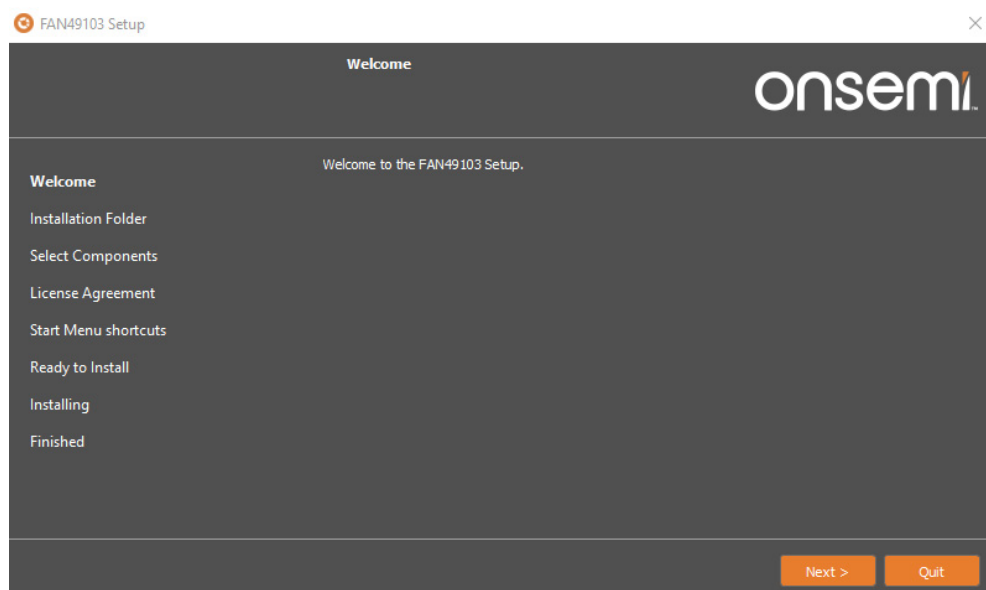

Figure 2. FAN49103 GUI Installation

- c. When prompted for Selecting Components, please check the box for PIC POD Driver to install appropriate drivers needed for USB Interface POD.

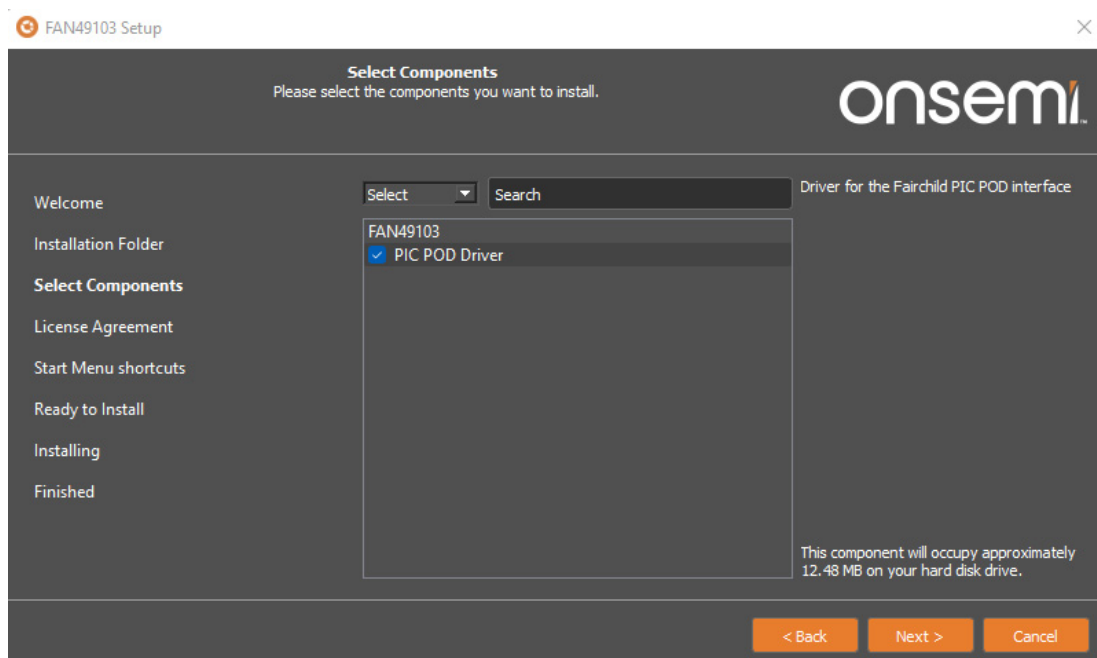

Figure 3. FAN49103 GUI Component Selection

- d. Once all steps have been completed, it will start installing the GUI.

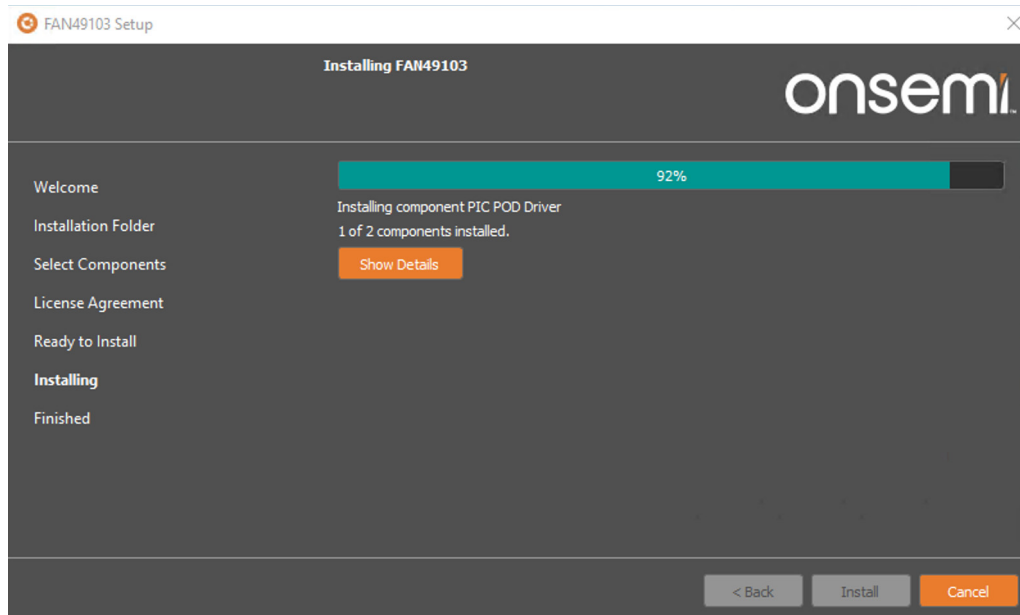

Figure 4. FAN49103 GUI Installation Update

- e. Once the installation is complete, FAN49103 GUI will open automatically
- f. You can find installed GUI at this path:
C:\Users*****\onsemi\FAN49103
- g. Below is a screen shot of the FAN49103 GUI that is used to communicate via I²C:

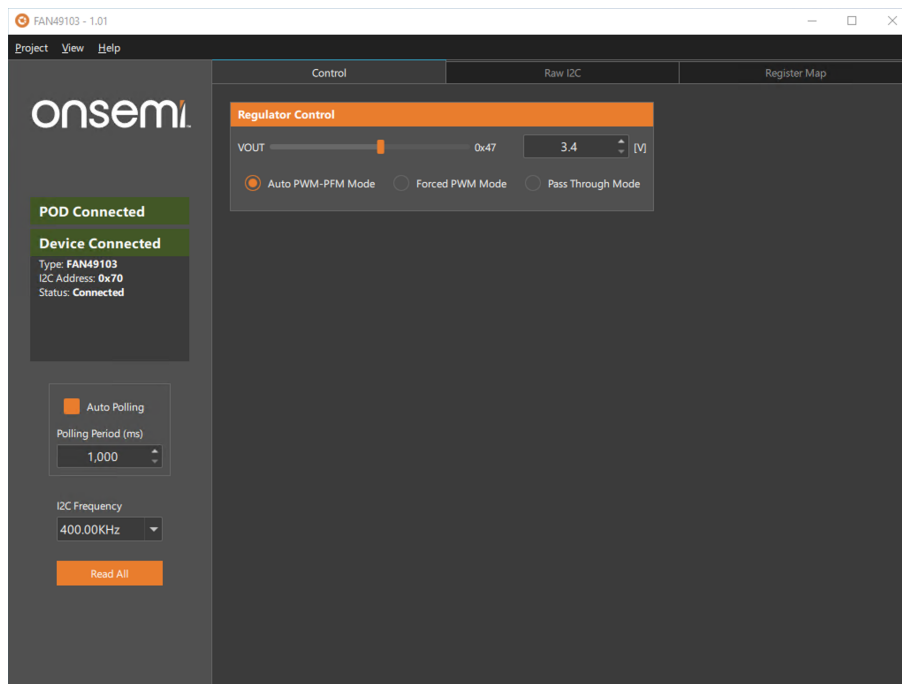

Figure 5. FAN49103 GUI Interface

EVBUM2955/D

GUI FEATURES

POD Connection

- a. Connect provided USB Interface POD with the device under test as shown in Figure 6.

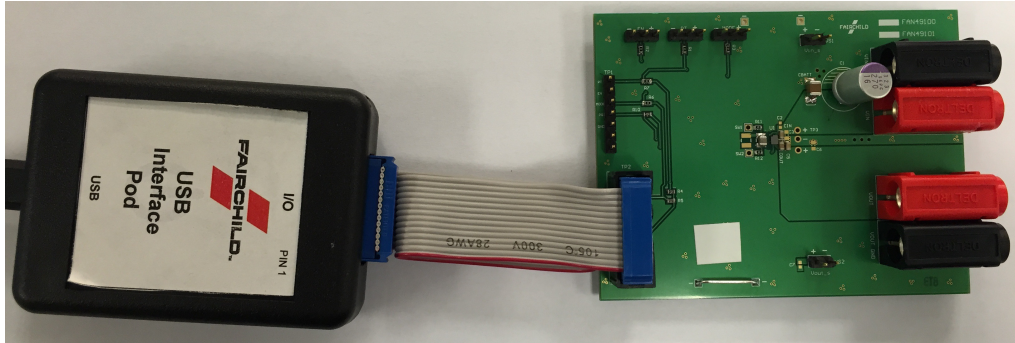

Figure 6. Connection of USB Interface POD to DUT

- b. Once the USB Interface POD is connected, it will show POD Connected on the GUI and if device is not connected it will show Device Disconnected. See Figure 7.

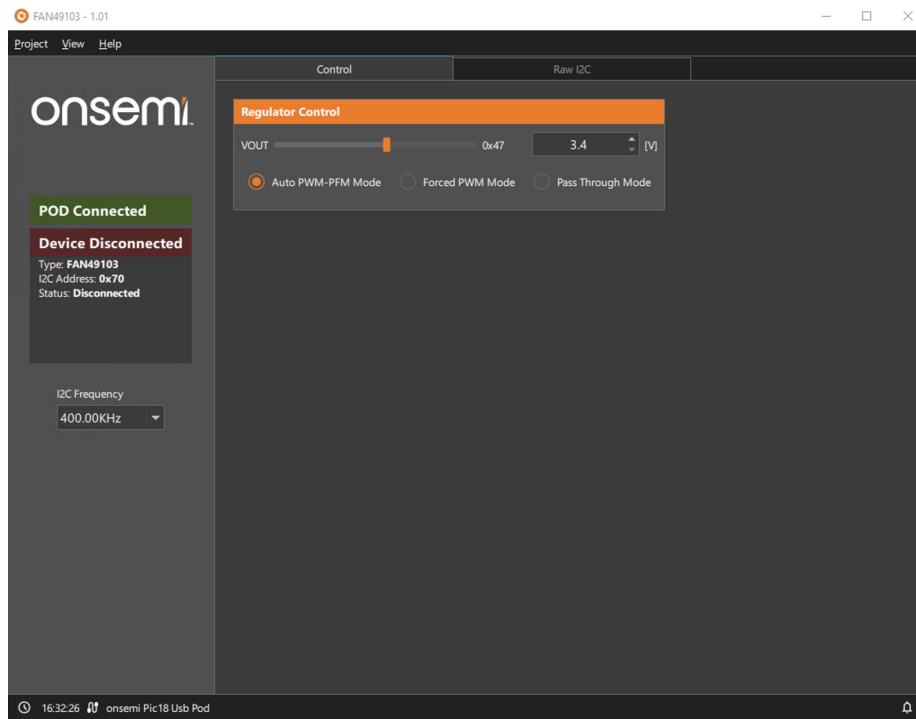

Figure 7. POD Connected

c. If POD is disconnected, it will show No POD Connection as shown in Figure 8.

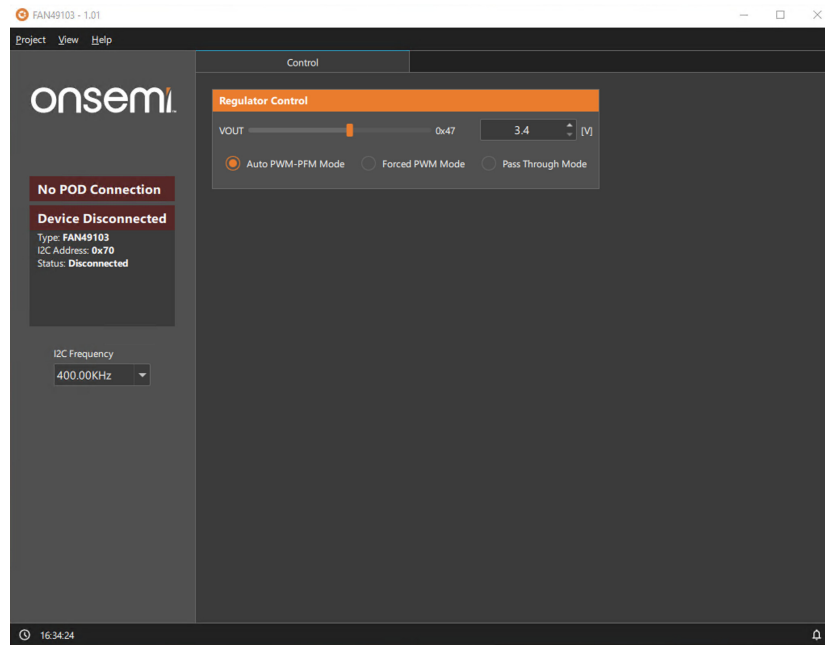

Figure 8. No POD Connection

Device Connection

When device is powered up, GUI will show Device Connected with the I²C slave address identified. Auto Polling is on by default at power on; GUI will poll the

registers automatically with Polling Period specified. If Auto Polling disabled, Read All button can be used to read registers & update the GUI anytime.

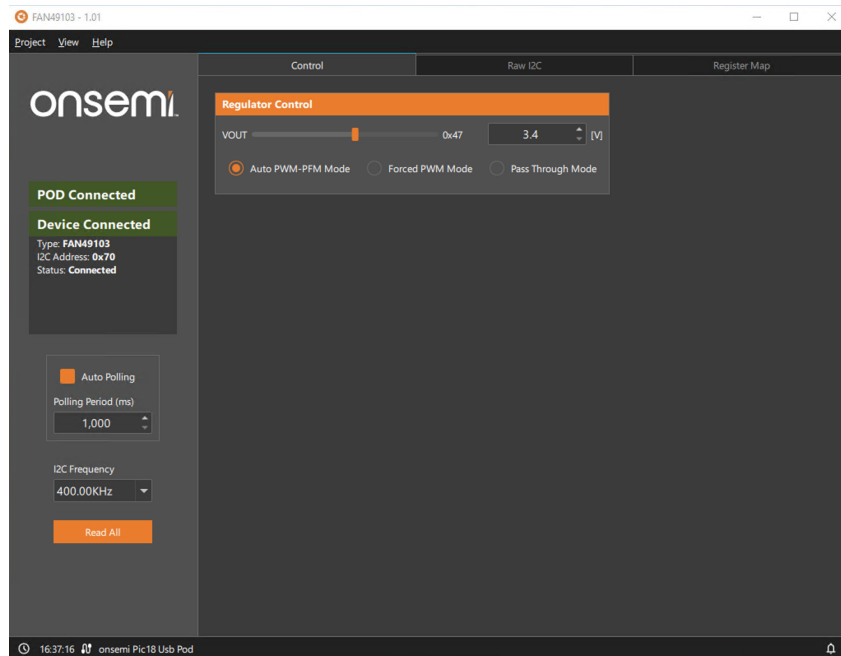

Figure 9. FAN49103 GUI Interface After Power-Up

Control Panel

Control Panel consists of Regulator Control with VOUT slider which sets output voltage from 2.5 V to 4.0 V. There

are options to select either “Auto PWM-PFM Mode” or “Forced PWM Mode” or “Pass-Through Mode”.

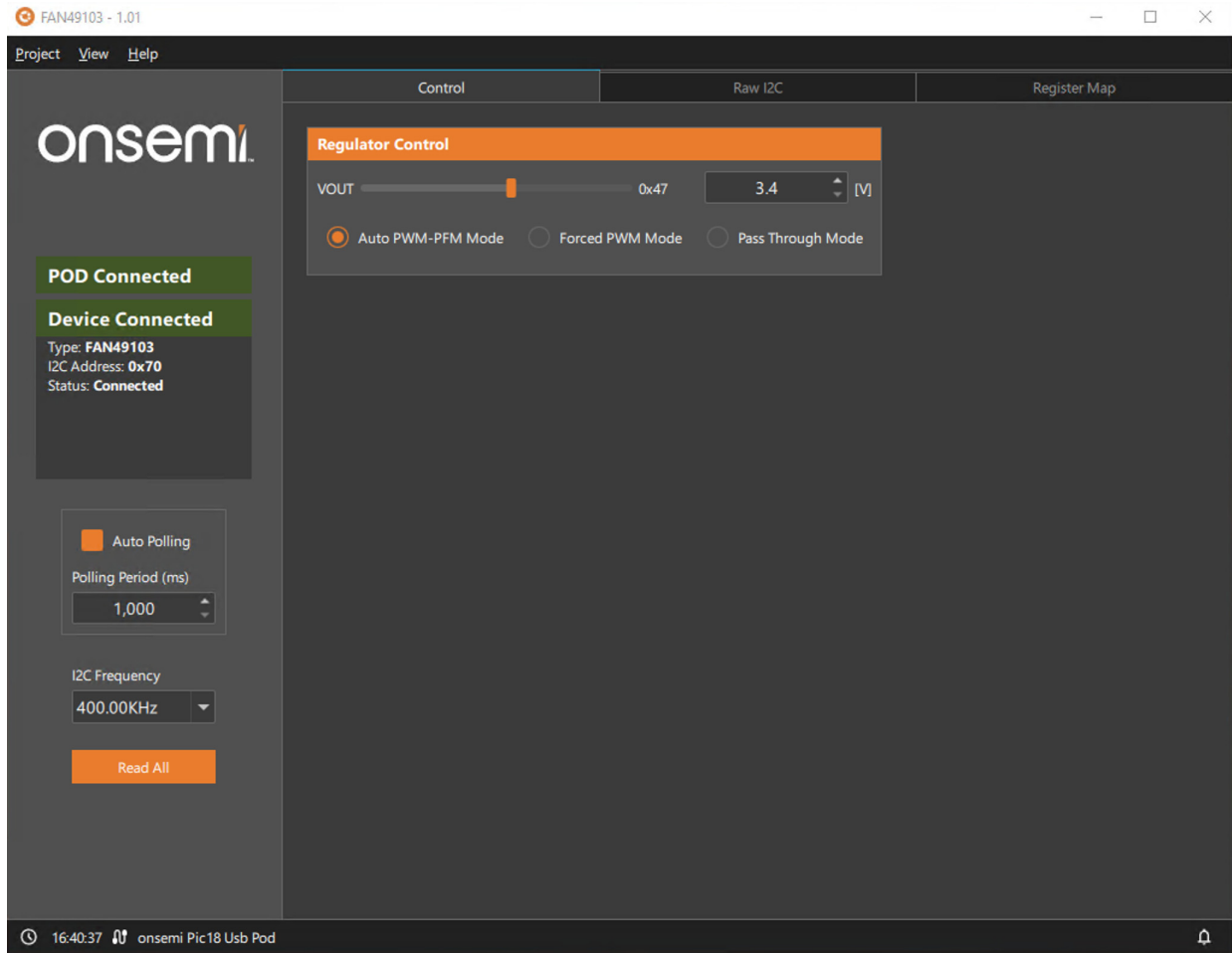

Figure 10. Control Panel

Register Map Panel

- a. Register Map allows control of individual bits of each Register.
- b. *Edit Register Window*: By double clicking on each Register “Edit Register” window will pop-up. Register value can be changed from this window.

Discard Changes: This option will revert the changes made by the user to the current register.

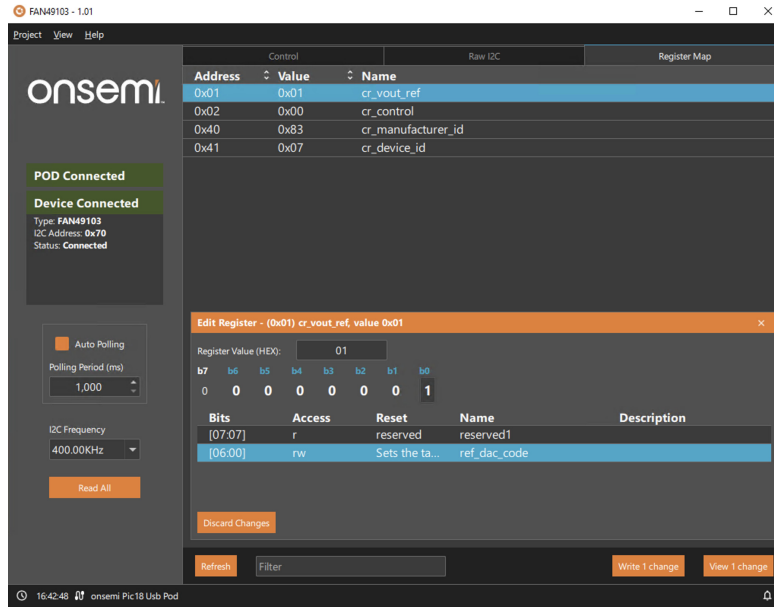

Figure 11. Edit Register Window

- c. *Write # changes*: This option will write all registers changed from the previous settings.

View # changes: This option will allow user to see what changes has been made from the last set of register settings and then write all changes together. Example of View changes Window is shown in Figure 12.

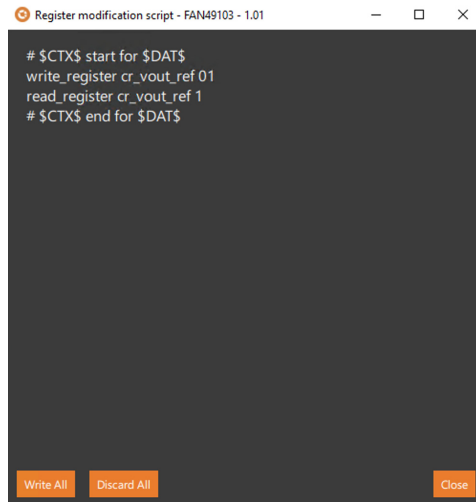

Figure 12. View Changes Window

Raw I²C Panel

- a. FAN49103 GUI allow user to write to or read from the known Slave Address with Hex values of data & Register info.

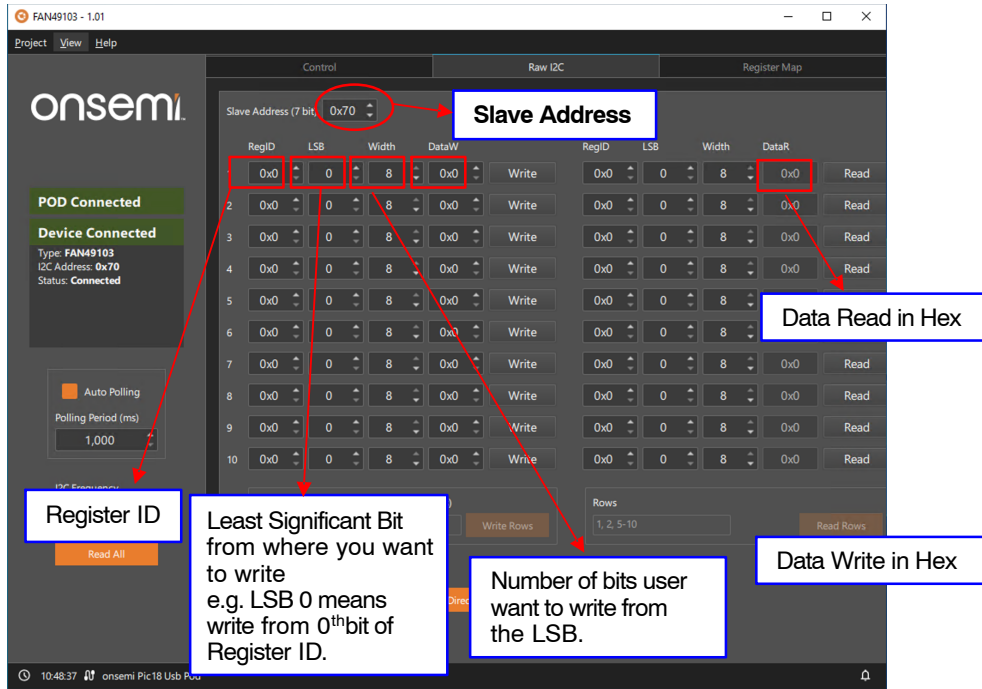

Figure 13. Raw I²C Panel Features (a)

- b. GUI has features to select I²C Clock Frequency, write/read registers sequentially, and save/load complete settings to/from .json file.

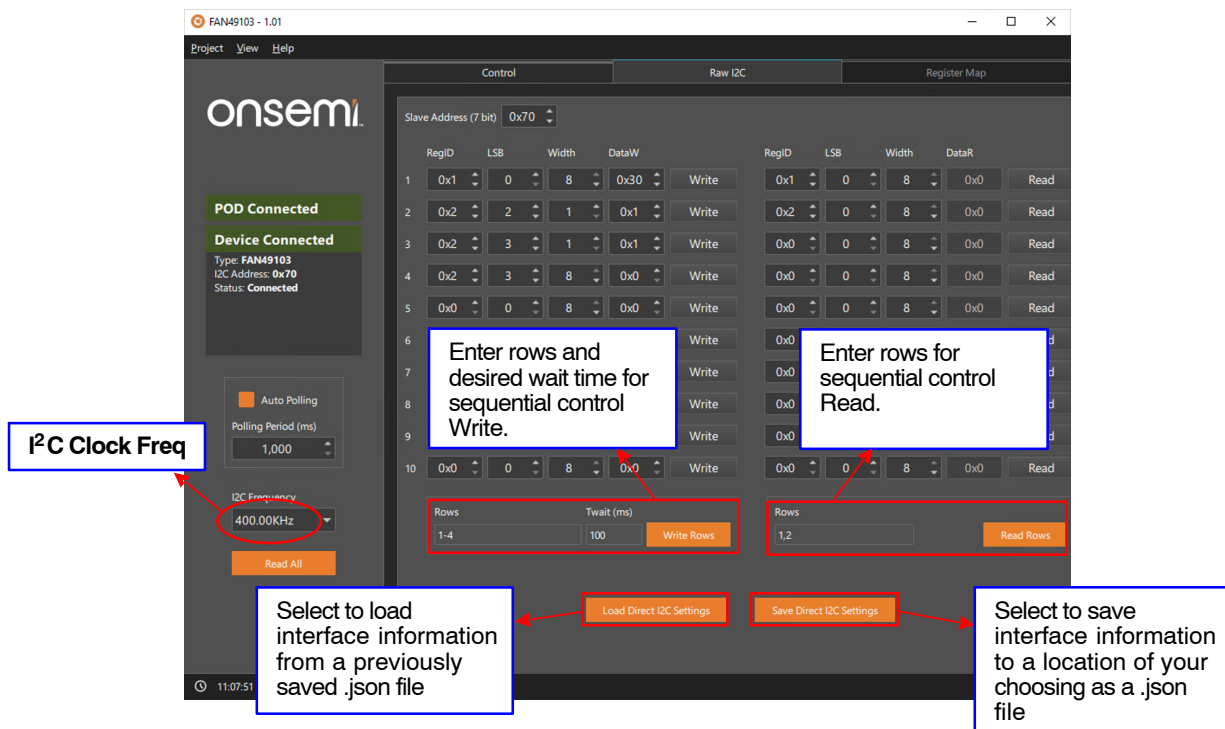

Figure 14. Raw I²C Panel Features (b)

c. *Communication Error*: If Slave-Address is not correct or communication with respective Slave Address fails it will give error on Write or Read

as in Figure 15, please make sure correct Slave Address is provided and try again.

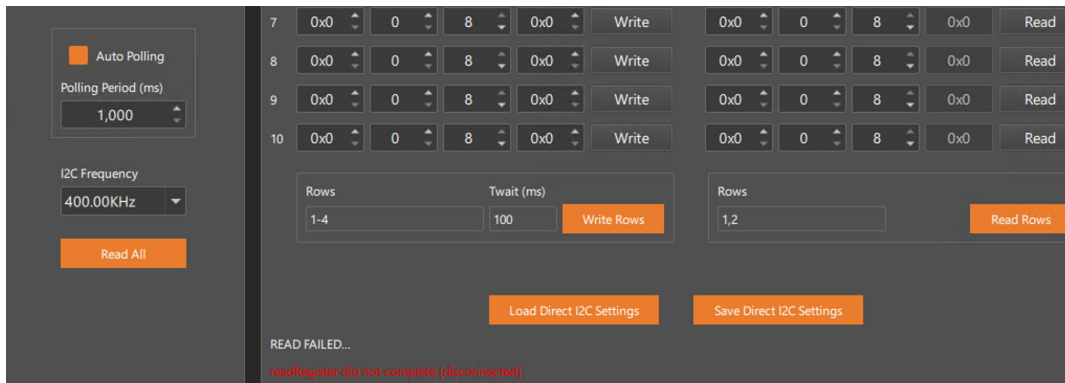

Figure 15. Raw I²C Communication Error

Support

a. *Windows*: FAN49103 GUI is supported by Windows 10 & 11 Platforms.

b. *Datasheet*: Navigate to Help → Datasheet for more information on the device and register information.

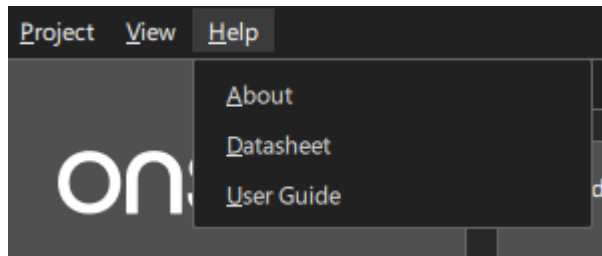

Figure 16. Help on FAN49103 GUI

c. *User Guide*: Navigate to Help → User Guide for more information on the GUI.

d. *Log & Communications Log*: User can view all communication made to & from IC in Communication log from View → Comms Log.

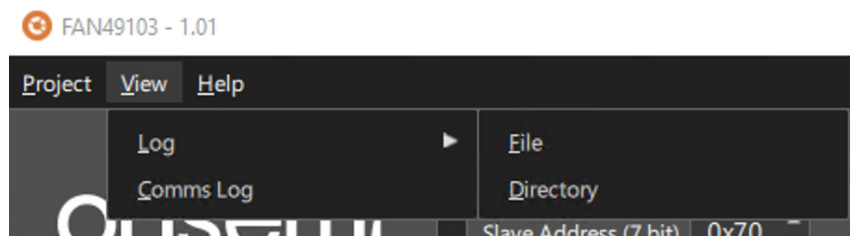

Figure 17. Communication Log

EVBUM2955/D

e. *Save/Open Configuration*: User can save their configuration of Control Panel to a .cfg file and

open the configuration later with the saved .cfg file to retrieve same control panel settings.

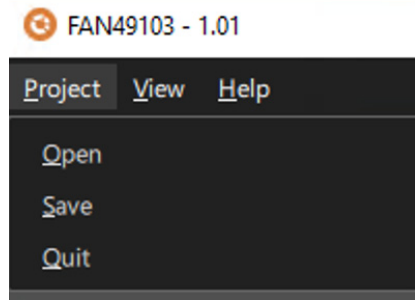

Figure 18. Save/Open Configuration

SCHEMATIC

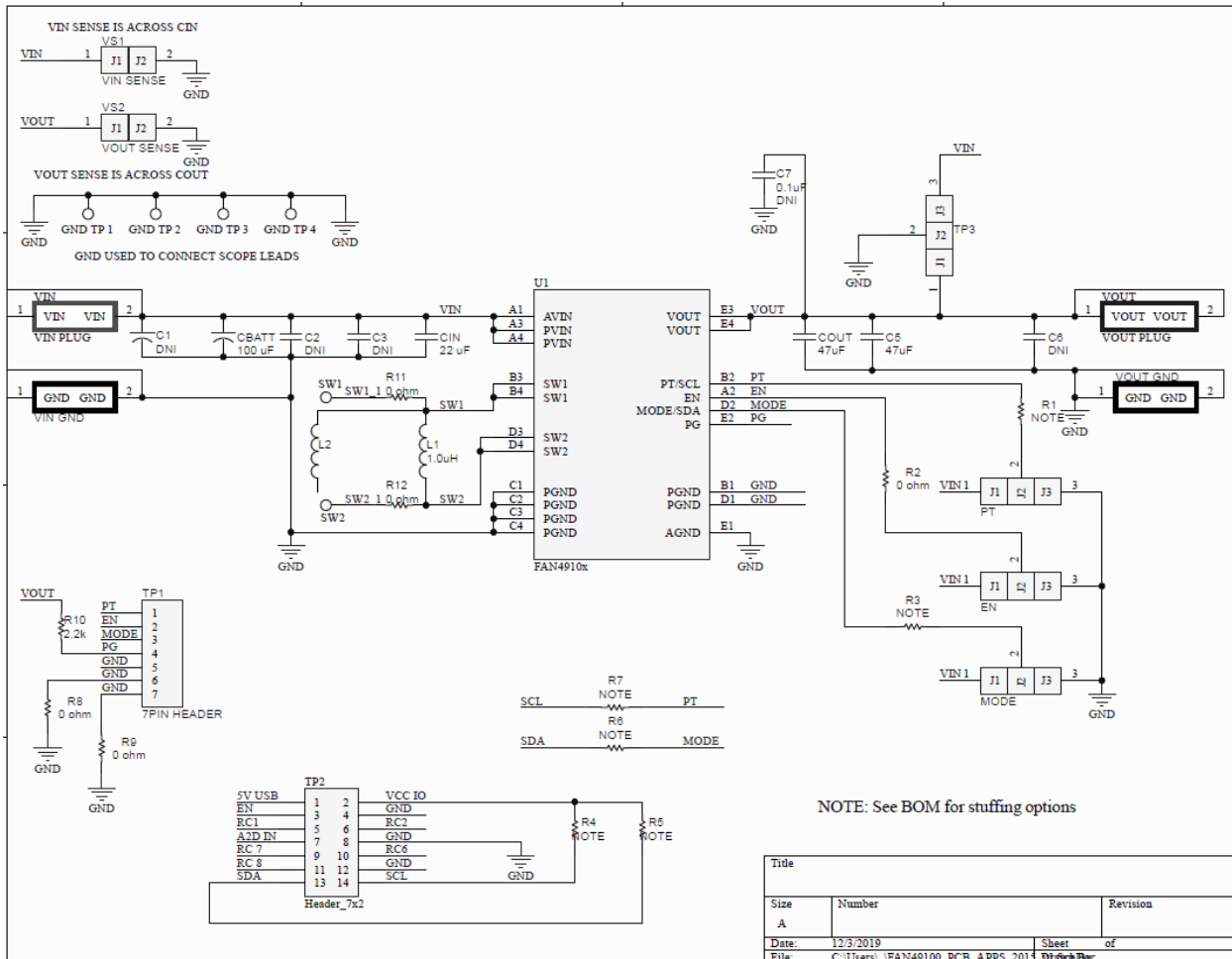

Figure 19. Evaluation Board Schematic

EVBUM2955/D

BILL OF MATERIALS

Table 1. BOM

FAN49101 & FAN49103 BOM			
Ref	Qty	Description	Manufacturer
U1	1	IC, Buck-Boost, WLCSP20	onsemi FAN4910x
L1	1	1.0 μ H, 4.2 Asat, 36 m Ω , 20%, 2016, 1 mm height	Cyntec HTEH20161T-1ROMSR
CIN	1	22 μ F, 6.3 V, 0603 (1608 METRIC)	Murata GRM187R61A226ME15
COUT, C5	2	47 μ F, 6.3 V, 0603 (1608 METRIC)	Murata GRM188R60J476ME15
CBATT	1	100 μ F, 10 V, 20%, X5R, 1210	Samsung CL32A107MPVNNNE
R2, R6, R7, R8, R9, R11, R12	7	0 Ω , 0603	
R4, R5, R10	3	2.2 k Ω , 0603	
EN	1	3x1 Header Strip, 125C	DigiKey SAM1098-03
VS1, VS2	2	2x1 Header Strip, 125C	DigiKey S1011E-02-ND
TP1	1	7x1 Header strip, 125C	
TP2	1	7x2 Header strip, 125C	DigiKey SAM1094-07
VOUT, VIN	2	Banana Jack, Red	Delton 571-0500 Mouser 164-6219
GND, GND	2	Banana Jack, Black	Delton 571-0100 Mouser 164-6218
GND	1	Bus Bar	
C1, C2, C3, C6, C7, TP3, PT, MODE, R3, R1	DNI		

FAN49100 BOM			
Ref	Qty	Description	Manufacturer
U1	1	IC, Buck-Boost, WLCSP20	onsemi FAN4910x
L1	1	1.0 μ H, 4.2 Asat, 36 m Ω , 20%, 2016, 1 mm height	Cyntec HTEH20161T-1ROMSR
CIN	1	22 μ F, 6.3 V, 0603 (1608 METRIC)	Murata GRM187R61A226ME15
COUT, C5	2	47 μ F, 6.3 V, 0603 (1608 METRIC)	Murata GRM188R60J476ME15
CBATT	1	100 μ F, 10 V, 20%, X5R, 1210	Samsung CL32A107MPVNNNE
RI, R2, R3, R8, R9, R11, R12	7	0 Ω , 0603	
R10	1	2.2 k Ω , 0603	
PT, EN, MODE	3	3x1 Header Strip, 125C	DigiKey SAM1098-03
VS1, VS2	2	2x1 Header Strip, 125C	DigiKey S1011E-02-ND
TP1	1	7x1 Header strip, 125C	
VOUT, VIN	2	Banana Jack, Red	Delton 571-0500 Mouser 164-6219
GND, GND	2	Banana Jack, Black	Delton 571-0100 Mouser 164-6218
GND	1	Bus Bar	
C1, C2, C3, C6, C7, TP3, TP2, R4, R5, R6, R7	DNI		

EVBUM2955/D

PRINTED CIRCUIT BOARD

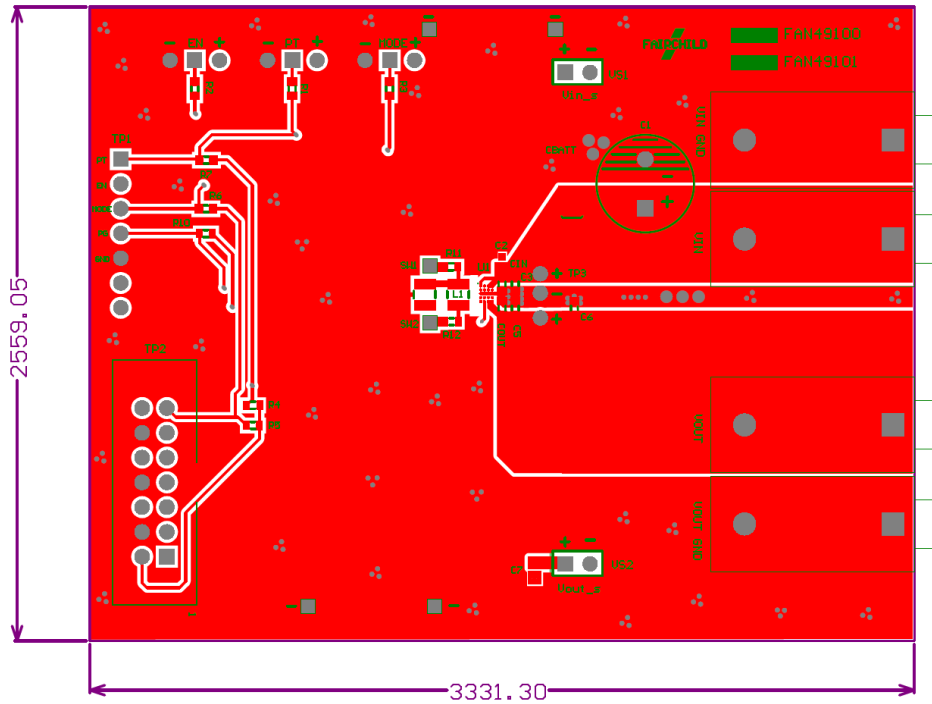

Figure 20. Top Layer

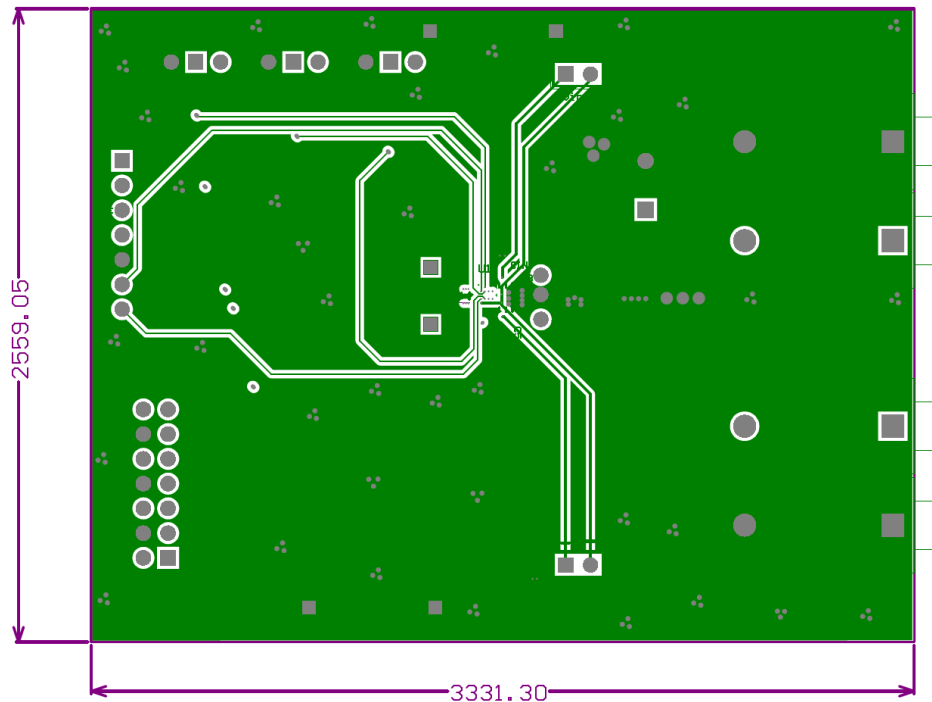

Figure 21. Mid-Layer 1

EVBUM2955/D

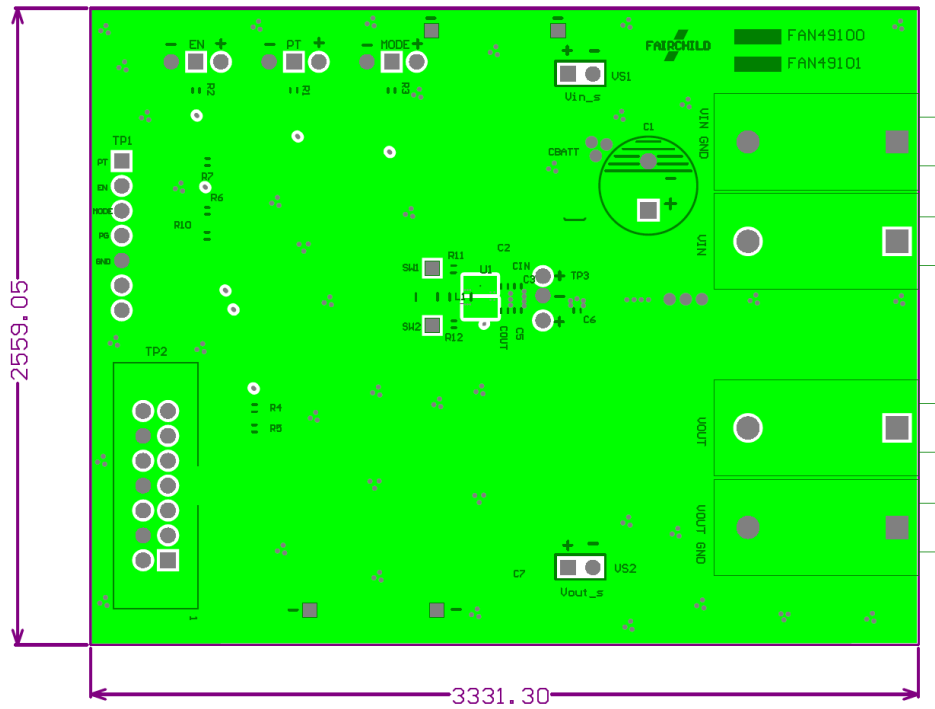
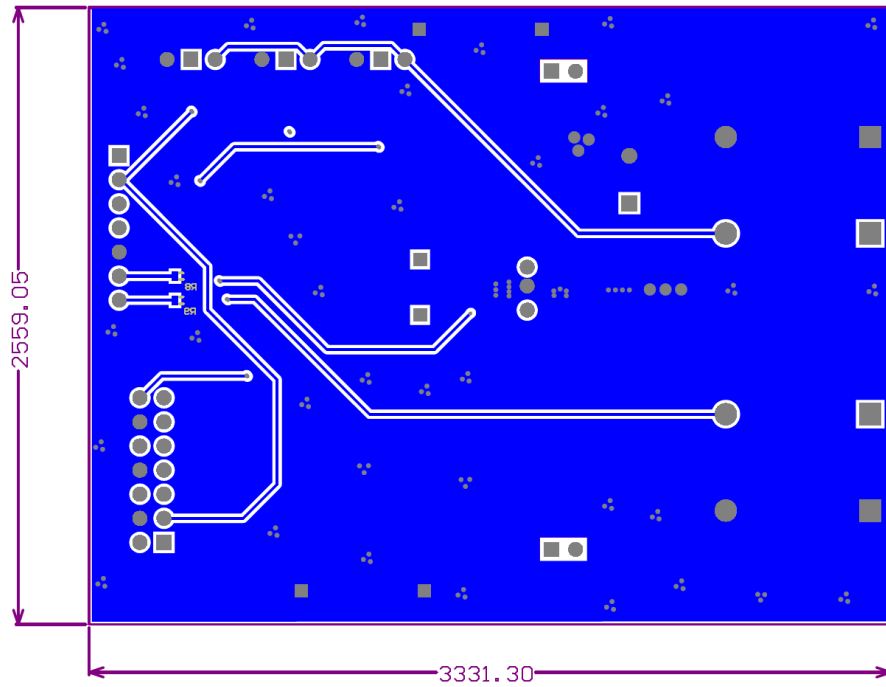

Figure 22. Mid-Layer 2



EVBUM2955/D

REVISION HISTORY

Revision	Description of Changes	Date
0	Initial document release.	4/28/2026

onsemi, **Onsemi**, and other names, marks, and brands are registered and/or common law trademarks of Semiconductor Components Industries, LLC dba "**onsemi**" or its affiliates and/or subsidiaries in the United States and/or other countries. **onsemi** owns the rights to a number of patents, trademarks, copyrights, trade secrets, and other intellectual property. A listing of **onsemi**'s product/patent coverage may be accessed at www.onsemi.com/site/pdf/Patent-Marking.pdf. **onsemi** is an Equal Opportunity/Affirmative Action Employer. This literature is subject to all applicable copyright laws and is not for resale in any manner.

The evaluation board/kit (research and development board/kit) (hereinafter the "board") is not a finished product and is not available for sale to consumers. The board is only intended for research, development, demonstration and evaluation purposes and will only be used in laboratory/development areas by persons with an engineering/technical training and familiar with the risks associated with handling electrical/mechanical components, systems and subsystems. This person assumes full responsibility/liability for proper and safe handling. Any other use, resale or redistribution for any other purpose is strictly prohibited.

THE BOARD IS PROVIDED BY ONSEMI TO YOU "AS IS" AND WITHOUT ANY REPRESENTATIONS OR WARRANTIES WHATSOEVER. WITHOUT LIMITING THE FOREGOING, ONSEMI (AND ITS LICENSORS/SUPPLIERS) HEREBY DISCLAIMS ANY AND ALL REPRESENTATIONS AND WARRANTIES IN RELATION TO THE BOARD, ANY MODIFICATIONS, OR THIS AGREEMENT, WHETHER EXPRESS, IMPLIED, STATUTORY OR OTHERWISE, INCLUDING WITHOUT LIMITATION ANY AND ALL REPRESENTATIONS AND WARRANTIES OF MERCHANTABILITY, FITNESS FOR A PARTICULAR PURPOSE, TITLE, NON-INFRINGEMENT, AND THOSE ARISING FROM A COURSE OF DEALING, TRADE USAGE, TRADE CUSTOM OR TRADE PRACTICE.

onsemi reserves the right to make changes without further notice to any board.

You are responsible for determining whether the board will be suitable for your intended use or application or will achieve your intended results. Prior to using or distributing any systems that have been evaluated, designed or tested using the board, you agree to test and validate your design to confirm the functionality for your application. Any technical, applications or design information or advice, quality characterization, reliability data or other services provided by **onsemi** shall not constitute any representation or warranty by **onsemi**, and no additional obligations or liabilities shall arise from **onsemi** having provided such information or services.

onsemi products including the boards are not designed, intended, or authorized for use in life support systems, or any FDA Class 3 medical devices or medical devices with a similar or equivalent classification in a foreign jurisdiction, or any devices intended for implantation in the human body. You agree to indemnify, defend and hold harmless **onsemi**, its directors, officers, employees, representatives, agents, subsidiaries, affiliates, distributors, and assigns, against any and all liabilities, losses, costs, damages, judgments, and expenses, arising out of any claim, demand, investigation, lawsuit, regulatory action or cause of action arising out of or associated with any unauthorized use, even if such claim alleges that **onsemi** was negligent regarding the design or manufacture of any products and/or the board.

This evaluation board/kit does not fall within the scope of the European Union directives regarding electromagnetic compatibility, restricted substances (RoHS), recycling (WEEE), FCC, CE or UL, and may not meet the technical requirements of these or other related directives.

FCC WARNING – This evaluation board/kit is intended for use for engineering development, demonstration, or evaluation purposes only and is not considered by **onsemi** to be a finished end product fit for general consumer use. It may generate, use, or radiate radio frequency energy and has not been tested for compliance with the limits of computing devices pursuant to part 15 of FCC rules, which are designed to provide reasonable protection against radio frequency interference. Operation of this equipment may cause interference with radio communications, in which case the user shall be responsible, at its expense, to take whatever measures may be required to correct this interference.

onsemi does not convey any license under its patent rights nor the rights of others.

LIMITATIONS OF LIABILITY: **onsemi** shall not be liable for any special, consequential, incidental, indirect or punitive damages, including, but not limited to the costs of requalification, delay, loss of profits or goodwill, arising out of or in connection with the board, even if **onsemi** is advised of the possibility of such damages. In no event shall **onsemi**'s aggregate liability from any obligation arising out of or in connection with the board, under any theory of liability, exceed the purchase price paid for the board, if any.

The board is provided to you subject to the license and other terms per **onsemi**'s standard terms and conditions of sale. For more information and documentation, please visit www.onsemi.com.

ADDITIONAL INFORMATION

TECHNICAL PUBLICATIONS:

Technical Library: www.onsemi.com/design/resources/technical-documentation
onsemi Website: www.onsemi.com

ONLINE SUPPORT: www.onsemi.com/support

For additional information, please contact your local Sales Representative at www.onsemi.com/support/sales