



ON Semiconductor

## Test Procedure for the NCP1597A Evaluation Board

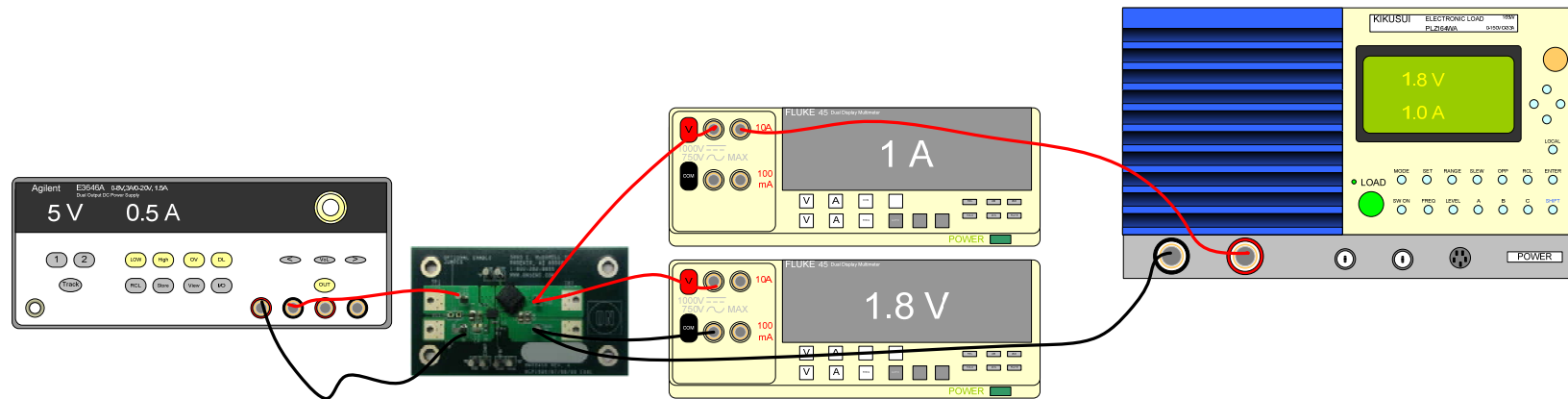

Figure 1: Test Setup

The following steps describe the test procedure for all of these boards:

### Suggested Equipment:

Current limited DC Power Supply (e.g. AGILENT 6645A) .....	1pc
DC Volt-Meter able to measure up to 60 V DC (e.g. KEITHLEY 2000) .....	2pcs
DC Amp-Meter able to measure up to 1 A DC (e.g. KEITHLEY 2000) .....	1pc
DC Amp-Meter able to measure up to 6 A DC (e.g. FLUKE 89 IV).....	1pc
DC Electronic Load (e.g. AGILENT 6060B) .....	1pc

**Test Procedure:**

1. Connect the test setup as shown in Figure 1.
2. Apply an input voltage,  $V_{IN} = 4-5 \text{ Vdc}$  (Current Limit must be set to 4A)
5. Apply  $I_{OUT}(\text{load}) = 0 \text{ A}$
4. Check that  $V_{OUT} = 1.7 - 1.9 \text{ Vdc}$
6. Set  $I_{OUT}$  to desired level 0 A- 2 A
7. Check that  $V_{OUT} = 1.7 - 1.9 \text{ Vdc}$
8. Turn off the load
9. Turn off  $V_{IN}$
10. End of the test