



## Test Procedure for the NCP59801MLADJTCG Demo Board

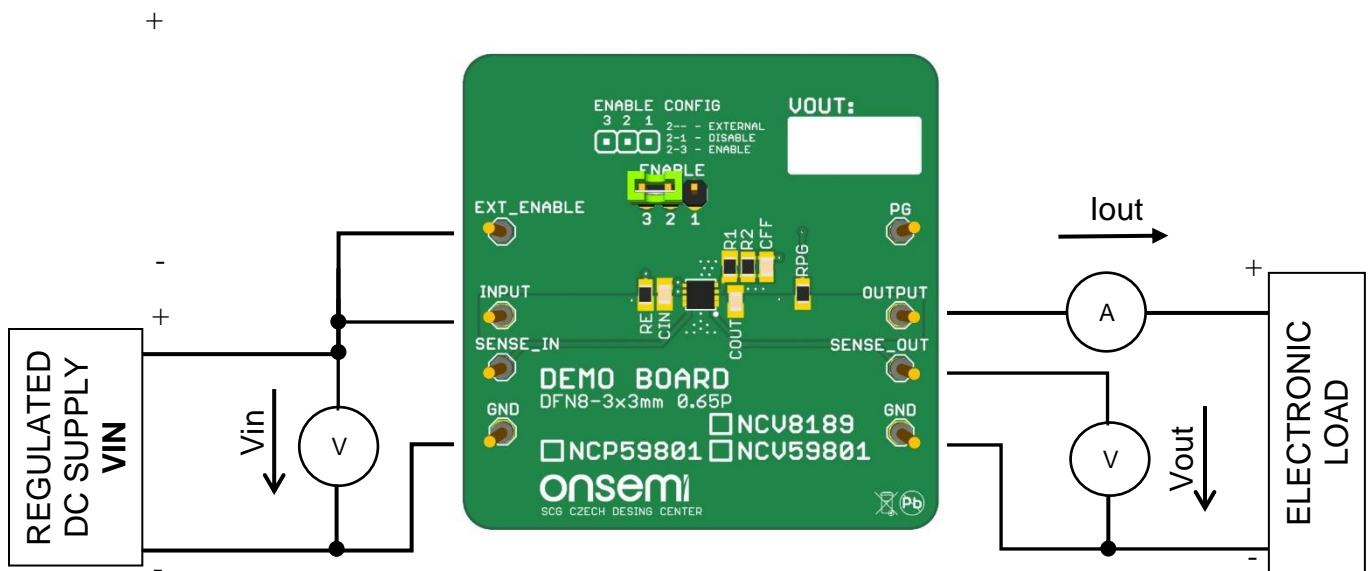

Figure 1: Test Setup

### Test Procedure

1. Connect the test setup as shown in Figure 1.
2. Apply supply voltage  $V_{in} = 5\text{ V}$
3. Apply  $I_{out} = 10\text{ mA}$  load.
4. Increase  $I_{out}$  load current to 1 A
5. Check the Output Voltage  $V_{out}$  is  $V_{out} @ 10\text{ mA} \pm 1.0\%$
6. Power down the load
7. Power down  $V_{in}$
8. End of test