

# TEST PROCEDURE FOR T30LMPSR131CFCT080T2GEVB EVALUATION BOARD

## Test Setup

1. Set up Enable Jumper to short pins **2-4** → EN pin is connected to BIAS voltage
2. Connect supply voltage to the **INPUT** pin of the EVB and set voltage to 0.9 V.
3. Connect supply voltage to the **VBIAS** pin of the EVB and set voltage to 2.5 V.
4. Ensure that all grounds are properly connected and polarity is ok.
5. Turn-on the power supplies

## Output Voltage Verification

6. Measure the output voltage at the **SENSE\_OUT** pin.
7. Verify that the measured voltage is within the specified tolerance – **0.8 V ±0.8%**

## Bias Pin Current Measurement

8. Measure the input current drawn from the **VBIAS** pin.
9. Confirm that the bias current is within the expected range - **80-100  $\mu$ A**

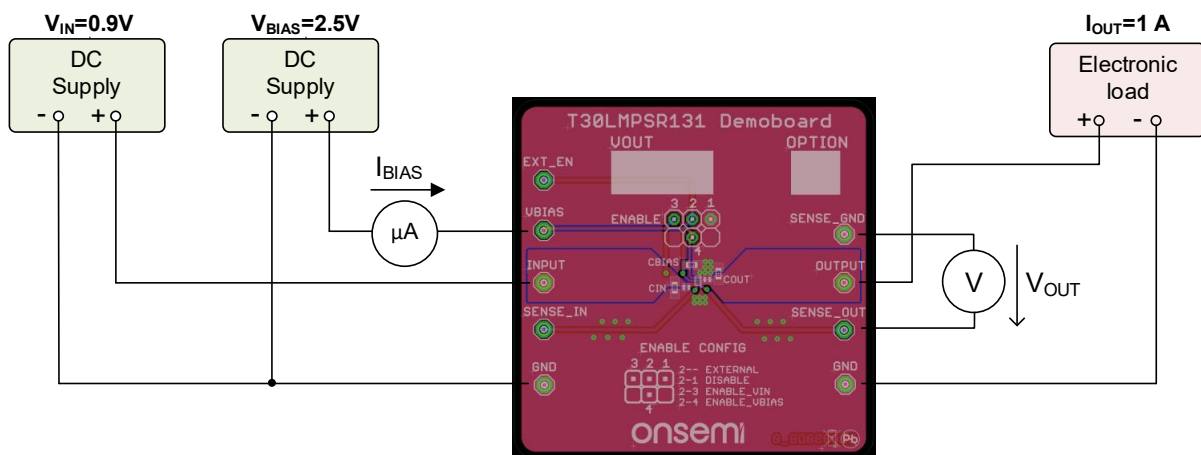

Figure 1: Test configuration for measurement  $V_{OUT}$  and  $I_{BIAS}$

## Check Output Voltage Under Load

10. Connect Electronic load to **OUTPUT** pin and set up output current to **1A**.
11. Turn-on the load.
12. Check that output current is 1A.
13. Verify that the measured voltage is within the specified tolerance – **0.8 V ±0.8%**