



Is Now Part of



ON Semiconductor®

To learn more about ON Semiconductor, please visit our website at
www.onsemi.com

ON Semiconductor and the ON Semiconductor logo are trademarks of Semiconductor Components Industries, LLC dba ON Semiconductor or its subsidiaries in the United States and/or other countries. ON Semiconductor owns the rights to a number of patents, trademarks, copyrights, trade secrets, and other intellectual property. A listing of ON Semiconductor's product/patent coverage may be accessed at www.onsemi.com/site/pdf/Patent-Marking.pdf. ON Semiconductor reserves the right to make changes without further notice to any products herein. ON Semiconductor makes no warranty, representation or guarantee regarding the suitability of its products for any particular purpose, nor does ON Semiconductor assume any liability arising out of the application or use of any product or circuit, and specifically disclaims any and all liability, including without limitation special, consequential or incidental damages. Buyer is responsible for its products and applications using ON Semiconductor products, including compliance with all laws, regulations and safety requirements or standards, regardless of any support or applications information provided by ON Semiconductor. "Typical" parameters which may be provided in ON Semiconductor data sheets and/or specifications can and do vary in different applications and actual performance may vary over time. All operating parameters, including "Typicals" must be validated for each customer application by customer's technical experts. ON Semiconductor does not convey any license under its patent rights nor the rights of others. ON Semiconductor products are not designed, intended, or authorized for use as a critical component in life support systems or any FDA Class 3 medical devices or medical devices with a same or similar classification in a foreign jurisdiction or any devices intended for implantation in the human body. Should Buyer purchase or use ON Semiconductor products for any such unintended or unauthorized application, Buyer shall indemnify and hold ON Semiconductor and its officers, employees, subsidiaries, affiliates, and distributors harmless against all claims, costs, damages, and expenses, and reasonable attorney fees arising out of, directly or indirectly, any claim of personal injury or death associated with such unintended or unauthorized use, even if such claim alleges that ON Semiconductor was negligent regarding the design or manufacture of the part. ON Semiconductor is an Equal Opportunity/Affirmative Action Employer. This literature is subject to all applicable copyright laws and is not for resale in any manner.

Using the V_{BB} Reference on High Speed LVDS Repeaters

Abstract

Fairchild's LVDS 2, 4, and 8-port repeaters are designed for high speed interconnects providing low Electromagnetic Interference (EMI) and low power dissipation at data rates up to 1.2Gb/s. The devices accept and generate LVDS levels with a typical output voltage of 330 mV. The devices are designed with a V_{BB} output reference voltage for AC coupling on the inputs. This application brief will discuss when to use AC coupling in an interconnect design and illustrate how to use the V_{BB} reference feature for optimizing the link.

Output Reference Voltage (V_{BB})

The V_{BB} reference is a design feature of Fairchild's LVDS repeaters which is simply a DC voltage reference used in applications employing AC coupling on the inputs. It is an internally generated DC voltage bias output that sources up to 275 μA of current. Test conditions used to characterize this feature were with V_{CC} = 3.3V and an

I_{BB} = 0 to -275 μA to guarantee minimum and maximum limits of 1.125V and 1.375V respectively. The V_{BB} pin does not have to be used and can be left floating.

When would the V_{BB} Reference Voltage be used?

Application specific requirements will determine whether the V_{BB} reference is needed. Typically when AC coupling is used to couple a transmitted differential signal to a receiver, the coupling capacitor blocks DC and thus the offset is no longer present at the receiver input. By connecting the V_{BB} output reference voltage between a split termination, it effectively provides a common mode voltage point for the differential signals. Refer to Figure 1 for the V_{BB} connection diagrams. The capacitor from V_{BB} pin to ground is used to stabilize the common mode voltage point. The value of the capacitor will be dependent on the specific application environment.

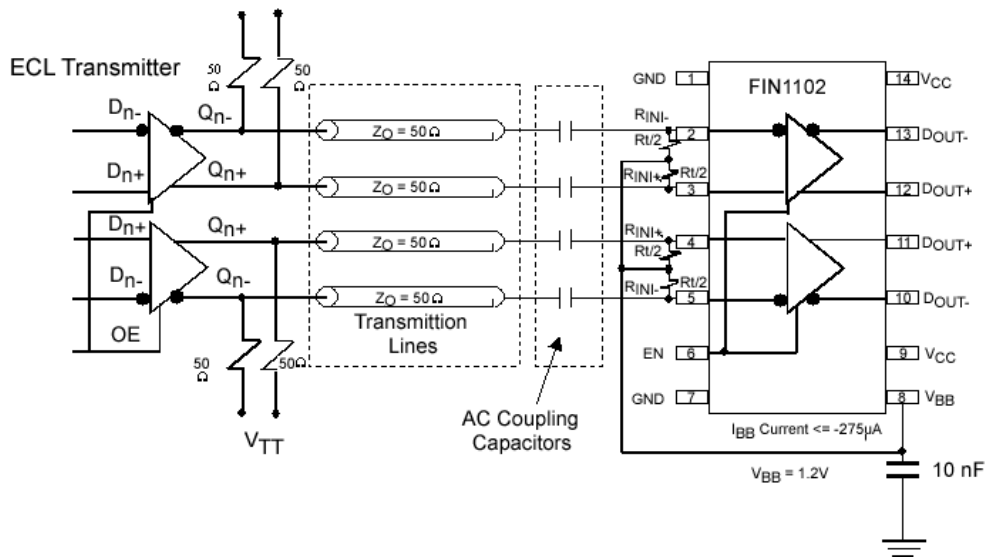

FIGURE 1. AC Coupling ECL to LVDS using the Output Reference Voltage (V_{BB})

Why AC-couple a Signal?

There are several reasons a designer would consider AC-coupling a signal, some of which include the following:

1. For interchangeability between different logic families with different switching thresholds it may be necessary to change the DC bias level to be compatible with the switching thresholds of the receiving device.
2. To couple differential signals transmitted between equipment with no DC connection required between the chassis. This will allow easier reception of the signals by the receiver without concern of the common-mode voltage range.

AC coupling is typically used only with binary signals having an equal number of ones and zeros such as clocks with a 50% duty cycle. A signal with DC balance is referred to as a signal having an equal number of ones and zeros. Without a DC bias, the receiver will not respond since the internal circuitry has no DC operation point, effectively never allowing the input transistors to bias up.

Summary

This application brief provides guidance for using the V_{BB} output reference feature on Fairchild's LVDS repeaters. V_{BB} can ease interchangeability and interfacing between different signaling standards.

Fairchild does not assume any responsibility for use of any circuitry described, no circuit patent licenses are implied and Fairchild reserves the right at any time without notice to change said circuitry and specifications.

LIFE SUPPORT POLICY

FAIRCHILD'S PRODUCTS ARE NOT AUTHORIZED FOR USE AS CRITICAL COMPONENTS IN LIFE SUPPORT DEVICES OR SYSTEMS WITHOUT THE EXPRESS WRITTEN APPROVAL OF THE PRESIDENT OF FAIRCHILD SEMICONDUCTOR CORPORATION. As used herein:

1. Life support devices or systems are devices or systems which, (a) are intended for surgical implant into the body, or (b) support or sustain life, and (c) whose failure to perform when properly used in accordance with instructions for use provided in the labeling, can be reasonably expected to result in a significant injury to the user.
2. A critical component in any component of a life support device or system whose failure to perform can be reasonably expected to cause the failure of the life support device or system, or to affect its safety or effectiveness.

www.fairchildsemi.com

ON Semiconductor and  are trademarks of Semiconductor Components Industries, LLC dba ON Semiconductor or its subsidiaries in the United States and/or other countries. ON Semiconductor owns the rights to a number of patents, trademarks, copyrights, trade secrets, and other intellectual property. A listing of ON Semiconductor's product/patent coverage may be accessed at www.onsemi.com/site/pdf/Patent-Marking.pdf. ON Semiconductor reserves the right to make changes without further notice to any products herein. ON Semiconductor makes no warranty, representation or guarantee regarding the suitability of its products for any particular purpose, nor does ON Semiconductor assume any liability arising out of the application or use of any product or circuit, and specifically disclaims any and all liability, including without limitation special, consequential or incidental damages. Buyer is responsible for its products and applications using ON Semiconductor products, including compliance with all laws, regulations and safety requirements or standards, regardless of any support or applications information provided by ON Semiconductor. "Typical" parameters which may be provided in ON Semiconductor data sheets and/or specifications can and do vary in different applications and actual performance may vary over time. All operating parameters, including "Typicals" must be validated for each customer application by customer's technical experts. ON Semiconductor does not convey any license under its patent rights nor the rights of others. ON Semiconductor products are not designed, intended, or authorized for use as a critical component in life support systems or any FDA Class 3 medical devices or medical devices with a same or similar classification in a foreign jurisdiction or any devices intended for implantation in the human body. Should Buyer purchase or use ON Semiconductor products for any such unintended or unauthorized application, Buyer shall indemnify and hold ON Semiconductor and its officers, employees, subsidiaries, affiliates, and distributors harmless against all claims, costs, damages, and expenses, and reasonable attorney fees arising out of, directly or indirectly, any claim of personal injury or death associated with such unintended or unauthorized use, even if such claim alleges that ON Semiconductor was negligent regarding the design or manufacture of the part. ON Semiconductor is an Equal Opportunity/Affirmative Action Employer. This literature is subject to all applicable copyright laws and is not for resale in any manner.

PUBLICATION ORDERING INFORMATION

LITERATURE FULFILLMENT:

Literature Distribution Center for ON Semiconductor
19521 E. 32nd Pkwy, Aurora, Colorado 80011 USA
Phone: 303-675-2175 or 800-344-3860 Toll Free USA/Canada
Fax: 303-675-2176 or 800-344-3867 Toll Free USA/Canada
Email: orderlit@onsemi.com

N. American Technical Support: 800-282-9855 Toll Free
USA/Canada
Europe, Middle East and Africa Technical Support:
Phone: 421 33 790 2910
Japan Customer Focus Center
Phone: 81-3-5817-1050

ON Semiconductor Website: www.onsemi.com
Order Literature: <http://www.onsemi.com/orderlit>
For additional information, please contact your local
Sales Representative