



Is Now Part of



ON Semiconductor®

To learn more about ON Semiconductor, please visit our website at
www.onsemi.com

ON Semiconductor and the ON Semiconductor logo are trademarks of Semiconductor Components Industries, LLC dba ON Semiconductor or its subsidiaries in the United States and/or other countries. ON Semiconductor owns the rights to a number of patents, trademarks, copyrights, trade secrets, and other intellectual property. A listing of ON Semiconductor's product/patent coverage may be accessed at www.onsemi.com/site/pdf/Patent-Marking.pdf. ON Semiconductor reserves the right to make changes without further notice to any products herein. ON Semiconductor makes no warranty, representation or guarantee regarding the suitability of its products for any particular purpose, nor does ON Semiconductor assume any liability arising out of the application or use of any product or circuit, and specifically disclaims any and all liability, including without limitation special, consequential or incidental damages. Buyer is responsible for its products and applications using ON Semiconductor products, including compliance with all laws, regulations and safety requirements or standards, regardless of any support or applications information provided by ON Semiconductor. "Typical" parameters which may be provided in ON Semiconductor data sheets and/or specifications can and do vary in different applications and actual performance may vary over time. All operating parameters, including "Typicals" must be validated for each customer application by customer's technical experts. ON Semiconductor does not convey any license under its patent rights nor the rights of others. ON Semiconductor products are not designed, intended, or authorized for use as a critical component in life support systems or any FDA Class 3 medical devices or medical devices with a same or similar classification in a foreign jurisdiction or any devices intended for implantation in the human body. Should Buyer purchase or use ON Semiconductor products for any such unintended or unauthorized application, Buyer shall indemnify and hold ON Semiconductor and its officers, employees, subsidiaries, affiliates, and distributors harmless against all claims, costs, damages, and expenses, and reasonable attorney fees arising out of, directly or indirectly, any claim of personal injury or death associated with such unintended or unauthorized use, even if such claim alleges that ON Semiconductor was negligent regarding the design or manufacture of the part. ON Semiconductor is an Equal Opportunity/Affirmative Action Employer. This literature is subject to all applicable copyright laws and is not for resale in any manner.

Reducing Switching Losses with QFET in a Step-up Converter

by B.C. Lim

Introduction

Efficiency is a critical factor in designing a switching mode power supply. With the increasing emphasis on efficiency, designers are concentrating on selecting MOSFETs with low switching losses. As frequencies increase, switching losses of the MOSFETs play a much greater role in the overall system losses.

Fairchild Semiconductor now offers a family of QFETs, the new power MOSFETs, which feature low on-resistance ($R_{DS(on)}$), and gate charge (Qg) characteristics to achieve lower switching and drive losses.

This application note describes a device which is effective in reducing system losses in a 70W step-up converter. This step-up converter is usually used in a C-Monitor.

Basic operation of a step-up converter

The step-up converter accepts a DC voltage input and provides a regulated output voltage which must be greater than the input voltage. The basic circuit configuration of a step-up converter is shown in Figure 1. When switch (Q1) is turned on, the supply voltage V_i is applied across inductor (L). The diode (D) is reverse biased by voltage V_o . Energy is transferred from the input supply voltage to the inductor. When switch (Q1) is turned off, the energy stored in the inductor (L) induces a voltage such that the diode conducts and delivers the energy to the output load (R) and the output capacitor (C). In addition to the energy stored in the inductor, additional energy is transferred from the input directly to the output during the diode conduction time.

By Volt-second balancing of the two switching periods on the inductor as follows:

$$V_i \cdot DT_s = (V_o - V_i) \cdot (1 - D)T_s \dots\dots (1)$$

Therefore:

$$V_o = \frac{1}{1 - D} V_i \dots\dots (2)$$

Controlling the duty cycle regulates the output voltage. Since the duty cycle is smaller than "1", the output voltage is always greater than the input voltage.

The inductor voltage:

$$v_L = L \frac{di}{dt} \dots\dots (3)$$

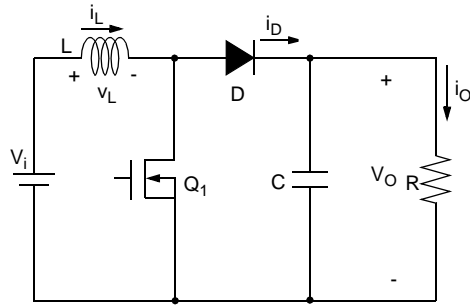

Figure 1. Basic circuit of a Step-up converter

Thus, when Q1 is turned on, the change in inductor current, Δi_L , is calculated as follows:

$$\Delta i_L = \frac{V_i}{L}DT_s \dots\dots\dots(4)$$

The average value of the inductor current, i_{av} , is:

$$i_{av} = \frac{1}{2}\Delta i_L + i_v = \frac{V_i}{2L}DT_s + i_v \dots\dots\dots(5)$$

The current averaged over a complete switching cycle is equal to the output current because the average current in the output capacitor must be equal to zero. Because i_o is equal to i_{av} , therefore:

$$i_v = i_o - \frac{V_i}{2L}DT_s \dots\dots\dots(6)$$

Being at the boundary between the continuous and the discontinuous mode the inductor current goes to zero at the end of the off period.

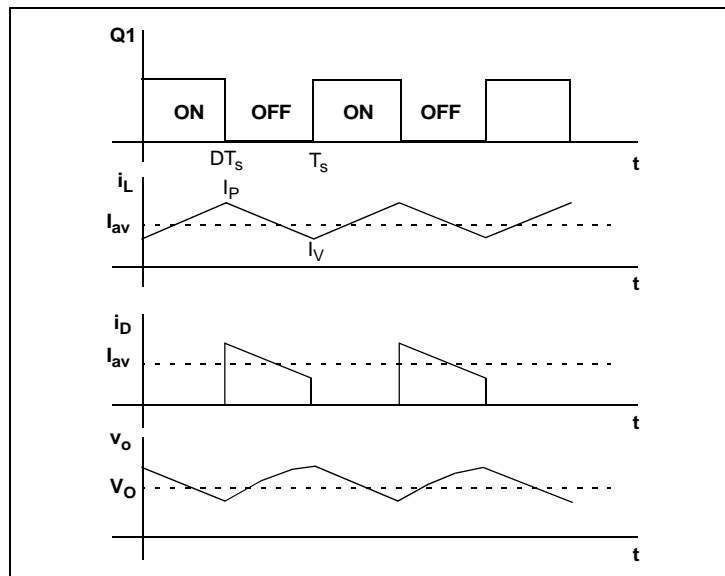

Figure 2. Waveform of each part

In continuous mode:

$$i_o > \frac{V_i}{2L} DT_s \dots \dots \dots (7)$$

To maintain low inductor peak current and good output ripple, it is recommended that Δi_L be about $0.3i_o$. Based on the above, Eq. (4) may be rewritten as follows:

$$L = \frac{V_i}{0.3i_{o, \max}} \cdot DT_s \dots \dots \dots (8)$$

In this step-up converter the input voltage is 50V; max. output current is 0.6A (70W); max. turn on time is $7.3\mu s$. Therefore,

$$L = \frac{50}{0.3 \times 0.6} \cdot 7.3 \times 10^{-6} = 2[\text{mH}]$$

While switch (Q1) is on, the output capacitor is discharged and the peak-peak voltage ripple Δv_o is given by

$$\Delta v_o = \frac{\Delta Q}{C} = \frac{i_o \cdot DT_s}{C} = \frac{V_o DT_s}{RC} = \frac{V_o D}{RCf} \dots \dots \dots (9)$$

Rearranging Eq.(9):

$$C = \frac{DT_s}{R} \times \frac{V_o}{\Delta v_o} \dots \dots \dots (10)$$

Δv_o is 1.2V(1%); DT_s is $7.3\mu s$; V_o is 120V. Thus, using Eq.(10) we obtain,

$$C = \frac{7.3}{200} \times \frac{120}{1.2} = 3.65[\mu F]$$

In this step-up converter we used a 500[μF] output capacitor for safe operation against the instantaneous variation of output load.

Main electrical characteristics of QFET

The trend in power supply design is focused on increasing efficiency by reducing loss. To obtain the high efficiency of a power system, it is important to select a switching device with low on-resistance ($R_{DS(on)}$) and gate charge (Qg) characteristics. Fairchild Semiconductor offers a family of QFET power MOSFETs that features on-resistance ratings which are lower than conventional devices by as much as 20 percent, balanced with gate charge characteristics that are reduced by 40 percent to achieve lower conduction and switching losses.

| Device | Package | $R_{DS(on)}$ [Ω] typical | Qg [nC] typical | $R_{DS(on)}$ Improvement | Qg Improvement |
|---------------------|---------|--------------------------------------|--------------------|-----------------------------|-------------------|
| FQP10N20 | TO-220 | 0.28 | 13.5 | 16.2% | 38.6% |
| Conventional Device | TO-220 | 0.334 | 22 | | |

Table 1: Comparison of improved Rds(on) and Qg ratings

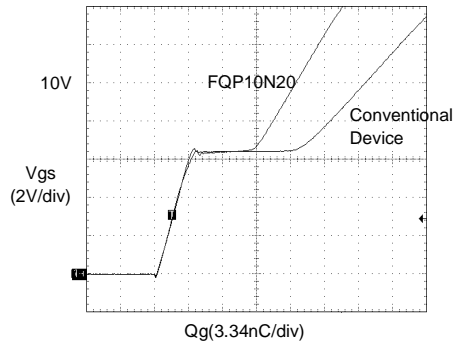

Figure 3. Gate Charge Comparison

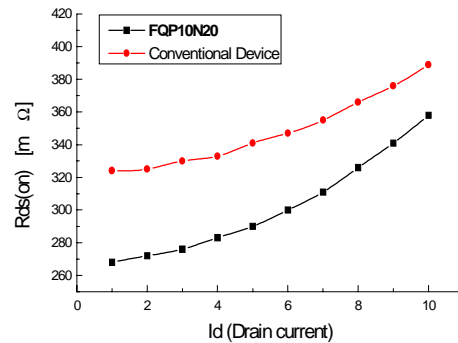
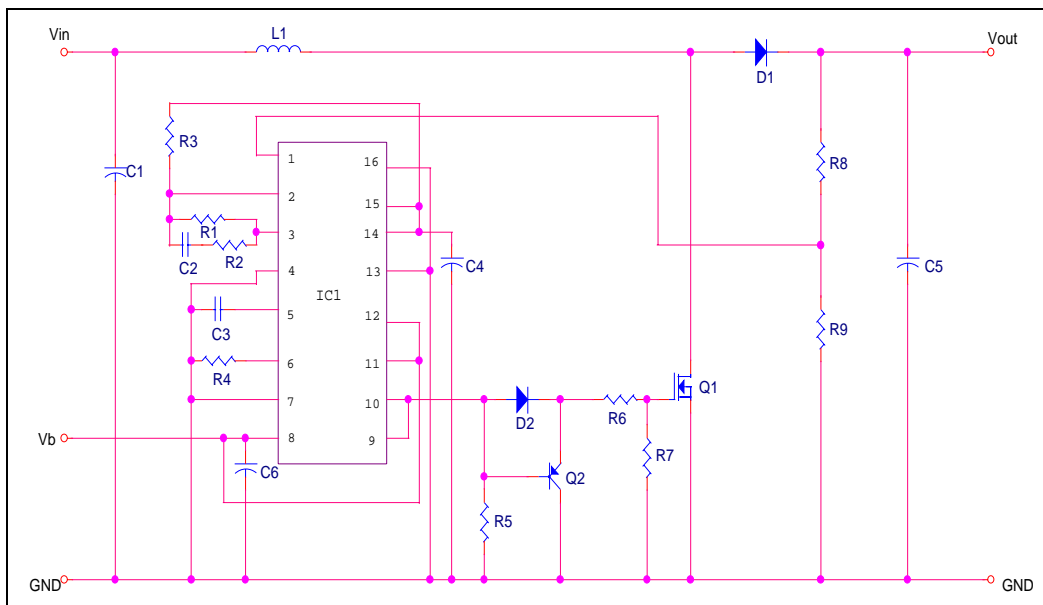

Figure 4. On-Resistance Comparison

Table 1 shows an example of the value for QFET (FQP10N20, 200V/10A), which is compared with a conventional MOSFET counterpart. Figure 3 shows the gate charge comparison graph between FQP10N20 and a conventional device. With the reduction of gate to drain capacitance (Miller capacitance), the total gate charge of a QFET (FQP10N20) is smaller than that of a conventional device by 40 percent. An advantage of this lower gate charge is reduced switching losses which improves efficiency in high frequency applications. Higher frequencies can also be employed, particularly to reduce the size of the inductor and heat sink. Figure 4 shows how $R_{DS(on)}$ varies under different drain current conditions. A QFET is lower than a conventional device by approximately 20 percent. A lower $R_{DS(on)}$ has the advantage of reducing conduction loss.



- Input voltage: DC 50V, output voltage: 120V \pm 1%
- Maximum output load: 70W
- Switching frequency: 80KHz
- Efficiency: 90% @Full load

Figure 5. Step-up Converter

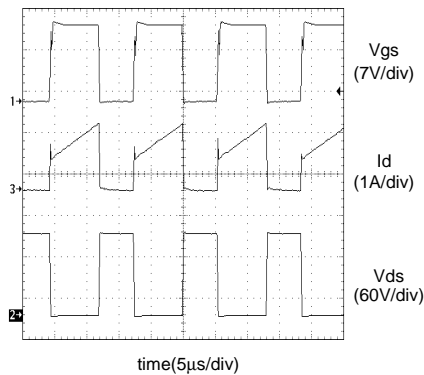

Figure 6. FQP10N20 Operating Waveform

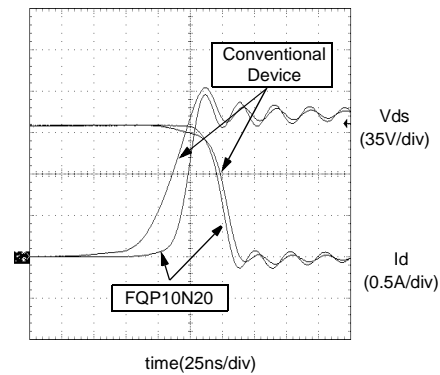

Figure 7. Switching off Waveform

The comparison of QFET & conventional MOSFET in step-up converter

Figure 5 shows a design of a 70W step-up converter having an 80kHz operating frequency, which is usually used in a C-Monitor. It accepts a DC 50 voltage input and provides a regulated DC 120 voltage output. In this circuit we used a KA7500B (Fairchild Semiconductor), which is a voltage mode PWM IC. Figure 6 shows the operating waveform when the QFET (FQP10N20) is used as the switching device under a 52W output load and 80KHz operating frequency. When 15 volts is applied between the gate and source, the MOSFET fully turns on, and the drain current flows. Simultaneously, the drain-source voltage falls close to the ground level.

Figure 7 shows the switching-off waveform that compares a QFET with a conventional device at the same operating conditions as that of Figure 6. As shown, the QFET is faster than the conventional device in the rising time of drain to source voltage and the falling time of drain current. As a result, QFETs can reduce power losses in a power supply, facilitating either a smaller heat sink or cooler operation. Figure 8 shows the switching-off loss associated with QFETs and conventional MOSFETs. The area of the waveform is proportional to the energy that is dissipated in the device during turn-off. The loss area of the QFET is much less than that of a conventional device.

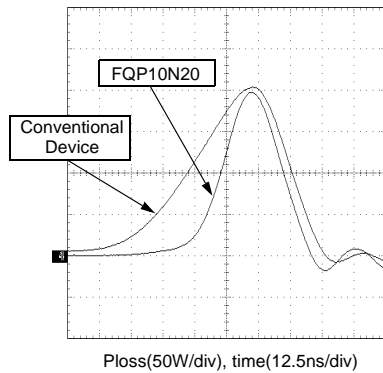

Figure 8. Switching off Loss Waveform

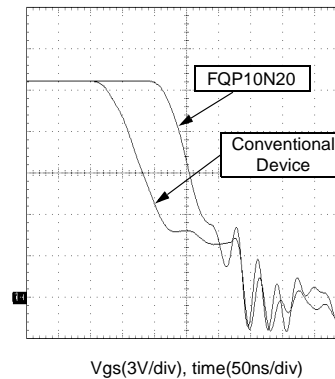

Figure 9. Vgs off Waveform

This is due to the low gate charge of the QFET. The difference in the switching loss between the two devices varies according to the value of the gate resistance (R_6). Figure 9 shows the shape of a gate to source voltage waveform during turn-off. As shown, the falling time of a QFET is shorter than that of a conventional counterpart. This is also the result of a low gate charge. Figure 10 was generated from test data obtained from the step-up converter, which operated under different operating frequency conditions and with a 52W output load. As shown, the QFET provides 2~4% higher efficiency. The difference between the two devices becomes more noticeable as frequencies increase.

Summary

Selecting MOSFETs with optimum characteristics is the key to designing a high efficiency switching power supply. A power MOSFET's contribution to converter losses is mostly due to conduction and switching losses. To improve efficiency, obtaining MOSFETs with low $R_{ds(on)}$ and Q_g is important. Fairchild Semiconductor introduces the QFET family, the new power MOSFETs, to address these needs. QFETs offer low on-resistance and gate charge specifications to improve the efficiency of the power system and to reduce heat-sinking requirements. The QFET family allows the designer to dramatically reduce switching losses, especially in high frequency applications. The overall system cost can be further reduced by operating this QFET family at high frequencies.

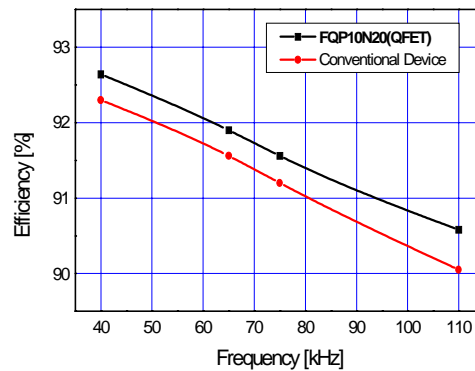
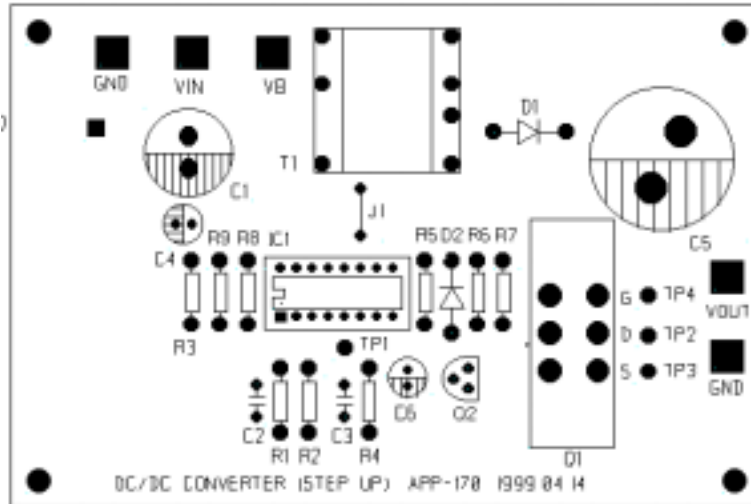

Figure 10. Efficiency Comparison Under Different Operating Frequency

Appendix

Circuit Board Layout



Parts List

| Part | Specification |
|------|----------------------|
| R1 | 1M Ω (1/4W) |
| R2 | 47K Ω (1/4W) |
| R3 | 5.1K Ω (1/4W) |
| R4 | 15K Ω (1/4W) |
| R5 | 1K Ω (1/4W) |
| R6 | 15 Ω (1/4W) |
| R7 | 47K Ω (1/4W) |
| R8 | 27K Ω (1/4W) |
| R9 | 1.2K Ω (1/4W) |
| Q1 | FQP10N20 (Fairchild) |
| Q2 | KSA733-Y (Fairchild) |

| Part | Specification |
|------|---------------------|
| C1 | 100 μ F (100V) |
| C2 | 0.1 μ F (104) |
| C3 | 0.001 μ F (102) |
| C4 | 0.1 μ F (104) |
| C5 | 500 μ F (200V) |
| C6 | 0.1 μ F (104) |
| D1 | FE6D |
| D2 | 1N4148 |
| L1 | 2mH |
| IC1 | KA7500B (Fairchild) |

TRADEMARKS

The following are registered and unregistered trademarks Fairchild Semiconductor owns or is authorized to use and is not intended to be an exhaustive list of all such trademarks.

| | | |
|----------------------|---------------|-------------|
| ACEx™ | HiSeC™ | SuperSOT™-8 |
| Bottomless™ | ISOPANAR™ | SyncFET™ |
| CoolFET™ | MICROWIRE™ | TinyLogic™ |
| CROSSVOLT™ | POP™ | UHC™ |
| E ² CMOS™ | PowerTrench® | VCX™ |
| FACT™ | QFET™ | |
| FACT Quiet Series™ | QS™ | |
| FAST® | Quiet Series™ | |
| FASTr™ | SuperSOT™-3 | |
| GTO™ | SuperSOT™-6 | |

DISCLAIMER

FAIRCHILD SEMICONDUCTOR RESERVES THE RIGHT TO MAKE CHANGES WITHOUT FURTHER NOTICE TO ANY PRODUCTS HEREIN TO IMPROVE RELIABILITY, FUNCTION OR DESIGN. FAIRCHILD DOES NOT ASSUME ANY LIABILITY ARISING OUT OF THE APPLICATION OR USE OF ANY PRODUCT OR CIRCUIT DESCRIBED HEREIN; NEITHER DOES IT CONVEY ANY LICENSE UNDER ITS PATENT RIGHTS, NOR THE RIGHTS OF OTHERS.

LIFE SUPPORT POLICY

FAIRCHILD'S PRODUCTS ARE NOT AUTHORIZED FOR USE AS CRITICAL COMPONENTS IN LIFE SUPPORT DEVICES OR SYSTEMS WITHOUT THE EXPRESS WRITTEN APPROVAL OF FAIRCHILD SEMICONDUCTOR INTERNATIONAL.

As used herein:

1. Life support devices or systems are devices or which, (a) are intended for surgical implant into the body, or (b) support or sustain life, or (c) whose failure to perform when properly used in accordance with instructions for use provided in the labeling, can be reasonably expected to result in significant injury to the user.
2. A critical component is any component of a life support device or system whose failure to perform can be reasonably expected to cause the failure of the life support device or system, or to affect its safety or effectiveness.

PRODUCT STATUS DEFINITIONS

Definition of Terms

| Datasheet Identification | Product Status | Definition |
|--------------------------|------------------------|---|
| Advance Information | Formative or In Design | This datasheet contains the design specifications for product development. Specifications may change in any manner without notice. |
| Preliminary | First Production | This datasheet contains preliminary data, and supplementary data will be published at a later date. Fairchild Semiconductor reserves the right to make changes at any time without notice in order to improve design. |
| No Identification Needed | Full Production | This datasheet contains final specifications. Fairchild Semiconductor reserves the right to make changes at any time without notice in order to improve design. |
| Obsolete | Not In Production | This datasheet contains specifications on a product that has been discontinued by Fairchild semiconductor. The datasheet is printed for reference information only. |

ON Semiconductor and  are trademarks of Semiconductor Components Industries, LLC dba ON Semiconductor or its subsidiaries in the United States and/or other countries. ON Semiconductor owns the rights to a number of patents, trademarks, copyrights, trade secrets, and other intellectual property. A listing of ON Semiconductor's product/patent coverage may be accessed at www.onsemi.com/site/pdf/Patent-Marking.pdf. ON Semiconductor reserves the right to make changes without further notice to any products herein. ON Semiconductor makes no warranty, representation or guarantee regarding the suitability of its products for any particular purpose, nor does ON Semiconductor assume any liability arising out of the application or use of any product or circuit, and specifically disclaims any and all liability, including without limitation special, consequential or incidental damages. Buyer is responsible for its products and applications using ON Semiconductor products, including compliance with all laws, regulations and safety requirements or standards, regardless of any support or applications information provided by ON Semiconductor. "Typical" parameters which may be provided in ON Semiconductor data sheets and/or specifications can and do vary in different applications and actual performance may vary over time. All operating parameters, including "Typicals" must be validated for each customer application by customer's technical experts. ON Semiconductor does not convey any license under its patent rights nor the rights of others. ON Semiconductor products are not designed, intended, or authorized for use as a critical component in life support systems or any FDA Class 3 medical devices or medical devices with a same or similar classification in a foreign jurisdiction or any devices intended for implantation in the human body. Should Buyer purchase or use ON Semiconductor products for any such unintended or unauthorized application, Buyer shall indemnify and hold ON Semiconductor and its officers, employees, subsidiaries, affiliates, and distributors harmless against all claims, costs, damages, and expenses, and reasonable attorney fees arising out of, directly or indirectly, any claim of personal injury or death associated with such unintended or unauthorized use, even if such claim alleges that ON Semiconductor was negligent regarding the design or manufacture of the part. ON Semiconductor is an Equal Opportunity/Affirmative Action Employer. This literature is subject to all applicable copyright laws and is not for resale in any manner.

PUBLICATION ORDERING INFORMATION

LITERATURE FULFILLMENT:

Literature Distribution Center for ON Semiconductor
19521 E. 32nd Pkwy, Aurora, Colorado 80011 USA
Phone: 303-675-2175 or 800-344-3860 Toll Free USA/Canada
Fax: 303-675-2176 or 800-344-3867 Toll Free USA/Canada
Email: orderlit@onsemi.com

N. American Technical Support: 800-282-9855 Toll Free
USA/Canada
Europe, Middle East and Africa Technical Support:
Phone: 421 33 790 2910
Japan Customer Focus Center
Phone: 81-3-5817-1050

ON Semiconductor Website: www.onsemi.com
Order Literature: <http://www.onsemi.com/orderlit>
For additional information, please contact your local
Sales Representative