



May, 2003

Application Note 9033

DIP-Smart Power Module Test Board V

**SPM™ TEST BOARD for use in Isolated Inverter GND
(Interface using Optocouplers with Five Isolated Power Supplies)**

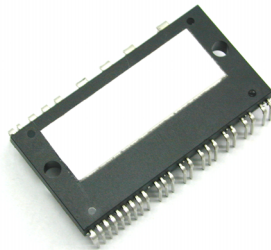

Schematics and External Interface Diagram

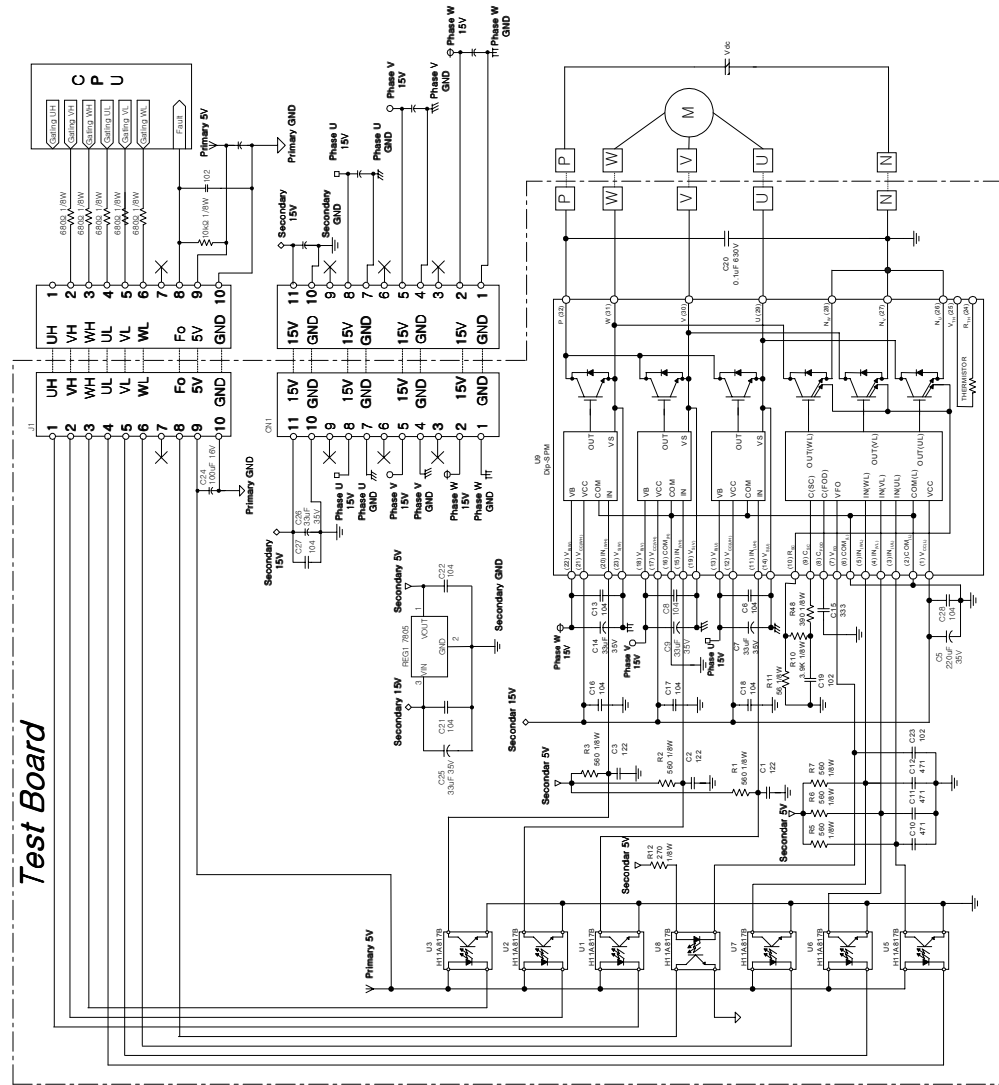

Note)

1. Dead time of $> 10\mu\text{s}$ would be required in order to prevent a inverter-leg from being arm-short. It depends on the optocoupler's characteristics. In this board, a slow and low-cost type of optocoupler is selected.
2. Five isolated power supplies are required.
 For the primary side: +5V for CPU operation.
 For the secondary side: +15V for SPM operation. +5V is generated by the use of the voltage regulator of 7805.
 For each U, V, W phase side: +15V for $V_{B(U, V, W)}$ and $V_{S(U, V, W)}$ operation of SPM.

PCB Map

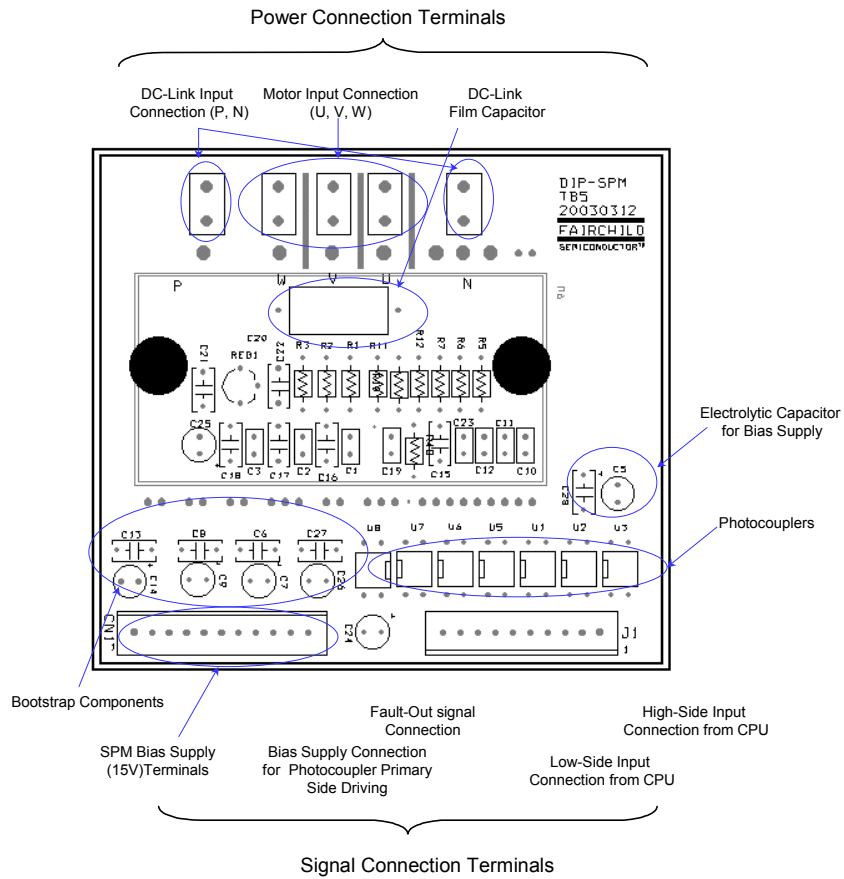

External Connection

Signal Interface 1 (J1)	1	High-Side Input Signal from CPU (Phase U)
	2	High-Side Input Signal from CPU (Phase V)
	3	High-Side Input Signal from CPU (Phase W)
	4	Low-Side Input Signal from CPU (Phase U)
	5	Low-Side Input Signal from CPU (Phase V)
	6	Low-Side Input Signal from CPU (Phase W)
	7	No connection
	8	Fault-Out Signal to CPU
	9	Bias Supply (+5V) Terminal for Photo coupler Primary Side Driving
	10	Bias Supply Ground Terminal for Photo coupler Primary Side Driving
Signal Interface 2 (CN1)	1	SPM Bias Supply +15V Terminal for High_Side (Phase W)
	2	SPM Bias Supply Ground Terminal for High_Side (Phase W)
	3	No Connection
	4	SPM Bias Supply +15V Terminal High_Side (Phase V)
	5	SPM Bias Supply Ground Terminal High_Side (Phase V)
	6	No Connection
	7	SPM Bias Supply +15V Terminal for High_Side (Phase U)
	8	SPM Bias Supply Ground Terminal for High_Side (Phase U)
	9	No Connection
	10	SPM Bias Supply +15V Terminal
	11	SPM Bias Supply Ground Terminal
Power Connection	P	Positive DC Link Input Connection
	N	Negative DC Link Input Connection
	U	Motor Input Connection (Phase U)
	V	Motor Input Connection (Phase V)
	W	Motor Input Connection (Phase W)

Photograph of Assembled PCB

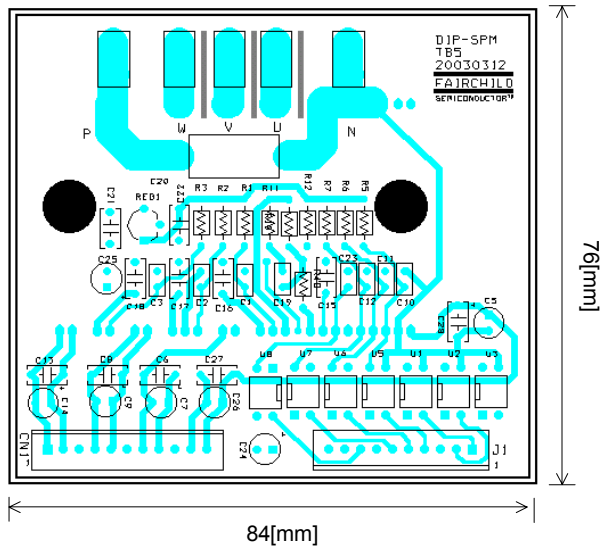

(a) Top Side View

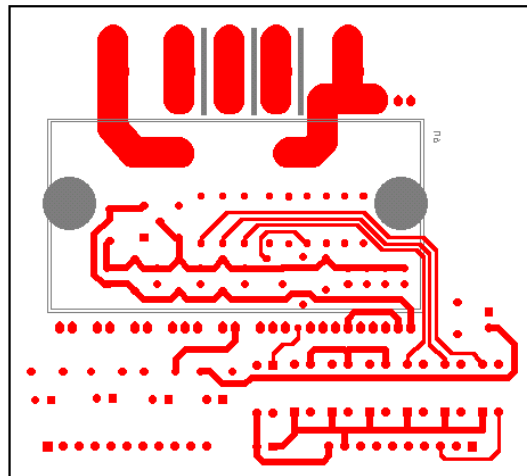

(b) Bottom Side View

Part List

Part No.	Rating	Characteristics	Definition
R1	560Ω, 1/8W	Carbon Film Resistor (5%)	Pull-Up Resistor (UH)
R2	560Ω, 1/8W	Carbon Film Resistor (5%)	Pull-Up Resistor (VH)
R3	560Ω, 1/8W	Carbon Film Resistor (5%)	Pull-Up Resistor (WH)
R4	20Ω, 1/4W	Carbon Film Resistor (5%)	Bootstrap Resistor (Phase U)
R5	560Ω, 1/8W	Carbon Film Resistor (5%)	Pull-Up Resistor (UL)
R6	560Ω, 1/8W	Carbon Film Resistor (5%)	Pull-Up Resistor (VL)
R7	560Ω, 1/8W	Carbon Film Resistor (5%)	Pull-Up Resistor (WL)
R8	20Ω, 1/4W	Carbon Film Resistor (5%)	Bootstrap Resistor (Phase V)
R9	20Ω, 1/4W	Carbon Film Resistor (5%)	Bootstrap Resistor (Phase W)
R10	3.9kΩ, 1/8W	Carbon Film Resistor (5%)	Low-Pass-Filter for Current Sensing
R11	56Ω, 1/8W	Carbon Film Resistor (5%)	Current Sensing Resistor
R12	270Ω, 1/8W	Carbon Film Resistor (5%)	Pull-Up Resistor (Fault-Out)
R48	390Ω, 1/8W	Carbon Film Resistor (5%)	Series Resistor for Csc
C1	1.2nF	Ceramic Capacitor	High-Side Pull-Up Capacitor (Phase U)
C2	1.2nF	Ceramic Capacitor	High-Side Pull-Up Capacitor (Phase V)
C3	1.2nF	Ceramic Capacitor	High-Side Pull-Up Capacitor (Phase W)
C5	33μF, 35V	Electrolytic Capacitor	+15V Bias Voltage Source Capacitor
C6	100nF	Ceramic Capacitor	Bypass Capacitor for Bootstrap Supply (Phase U)
C7	33μF, 35V	Electrolytic Capacitor	Bootstrap Capacitor (Phase U)
C8	100nF	Ceramic Capacitor	Bypass Capacitor for Bootstrap Supply (Phase V)
C9	33μF, 35V	Electrolytic Capacitor	Bootstrap Capacitor (Phase V)
C10	470pF	Ceramic Capacitor	Low-Side Pull-Up Capacitor (Phase U)
C11	470pF	Ceramic Capacitor	Low-Side Pull-Up Capacitor (Phase V)
C12	470pF	Ceramic Capacitor	Low-Side Pull-Up Capacitor (Phase W)
C13	100nF	Ceramic Capacitor	Bypass Capacitor for Bootstrap Supply (Phase W)
C14	33μF, 35V	Electrolytic Capacitor	Bootstrap Capacitor (Phase W)
C15	33nF	Ceramic Capacitor	Capacitor for Selection for Fault Out Duration
C16	100nF	Ceramic Capacitor	+15V Bias Voltage Bypass Capacitor (WH)
C17	100nF	Ceramic Capacitor	+15V Bias Voltage Bypass Capacitor (VH)
C18	100nF	Ceramic Capacitor	+15V Bias Voltage Bypass Capacitor (UH)
C19	1nF	Ceramic Capacitor	Low-Pass-Fault for Current Sensing
C20	0.1μF, 630V	Film Capacitor	Snubber Capacitor to Suppress the Spike-Voltage
C21	100nF	Ceramic Capacitor	+15V Bias Voltage Bypass Capacitor
C22	1μF	Monolithic Capacitor	+5V Bias Voltage Bypass Capacitor
C23	1nF	Ceramic Capacitor	Pull-Up Capacitor of Fault-Out Signal
C24	100μF, 16V	Electrolytic Capacitor	+5V Bias Voltage Source Capacitor (for the Primary Side)
C25	33μF, 35V	Electrolytic Capacitor	+15V Bias Voltage Source Capacitor
C26	33μF, 35V	Electrolytic Capacitor	+15V Bias Voltage Source Capacitor
C27	100nF	Ceramic Capacitor	+15V Bias Voltage Bypass Capacitor
C28	100nF	Ceramic Capacitor	+15V Bias Voltage Bypass Capacitor

Part List

Part No.	Rating	Characteristics	Definition
U1	B	Photocoupler (H11A817B)	Photocoupler for Signal Interface (UH)
U2	B	Photocoupler (H11A817B)	Photocoupler for Signal Interface (VH)
U3	B	Photocoupler (H11A817B)	Photocoupler for Signal Interface (WH)
U4	-	DIP-SPM	See the datasheet
U5	B	Photocoupler (H11A817B)	Photocoupler for Signal Interface (UL)
U6	B	Photocoupler (H11A817B)	Photocoupler for Signal Interface (VL)
U7	B	Photocoupler (H11A817B)	Photocoupler for Signal Interface (WL)
U8	B	Photocoupler (H11A817B)	Photocoupler for Signal Interface (Fault-Out)
REG1	100mA	Voltage Regulator (KA78L05A)	3-Terminal Positive Voltage Regulator

TRADEMARKS

The following are registered and unregistered trademarks Fairchild Semiconductor owns or is authorized to use and is not intended to be an exhaustive list of all such trademarks.

ACEx™	FACT™	ImpliedDisconnect™	PACMAN™	SPM™
ActiveArray™	FACT Quiet Series™	ISOPLANAR™	POP™	Stealth™
Bottomless™	FAST®	LittleFET™	Power247™	SuperSOT™-3
CoolFET™	FASTr™	MicroFET™	PowerTrench®	SuperSOT™-6
CROSSVOLT™	FRFET™	MicroPak™	QFET™	SuperSOT™-8
DOME™	GlobalOptoisolator™	MICROWIRE™	QS™	SyncFET™
EcoSPARK™	GTO™	MSX™	QT Optoelectronics™	TinyLogic®
E ² CMOS™	HiSeC™	MSXPro™	Quiet Series™	TruTranslation™
EnSigna™	I ² C™	OCX™	RapidConfigure™	UHC™
Across the board. Around the world.™		OCXPro™	RapidConnect™	UltraFET®
The Power Franchise™		OPTOLOGIC®	SILENT SWITCHER®	VCX™
Programmable Active Droop™		OPTOPLANAR™	SMART START™	

DISCLAIMER

FAIRCHILD SEMICONDUCTOR RESERVES THE RIGHT TO MAKE CHANGES WITHOUT FURTHER NOTICE TO ANY PRODUCTS HEREIN TO IMPROVE RELIABILITY, FUNCTION OR DESIGN. FAIRCHILD DOES NOT ASSUME ANY LIABILITY ARISING OUT OF THE APPLICATION OR USE OF ANY PRODUCT OR CIRCUIT DESCRIBED HEREIN; NEITHER DOES IT CONVEY ANY LICENSE UNDER ITS PATENT RIGHTS, NOR THE RIGHTS OF OTHERS.

LIFE SUPPORT POLICY

FAIRCHILD'S PRODUCTS ARE NOT AUTHORIZED FOR USE AS CRITICAL COMPONENTS IN LIFE SUPPORT DEVICES OR SYSTEMS WITHOUT THE EXPRESS WRITTEN APPROVAL OF FAIRCHILD SEMICONDUCTOR CORPORATION.

As used herein:

1. Life support devices or systems are devices or systems which, (a) are intended for surgical implant into the body, or (b) support or sustain life, or (c) whose failure to perform when properly used in accordance with instructions for use provided in the labeling, can be reasonably expected to result in significant injury to the user.
2. A critical component is any component of a life support device or system whose failure to perform can be reasonably expected to cause the failure of the life support device or system, or to affect its safety or effectiveness.

PRODUCT STATUS DEFINITIONS

Definition of Terms

Datasheet Identification	Product Status	Definition
Advance Information	Formative or In Design	This datasheet contains the design specifications for product development. Specifications may change in any manner without notice.
Preliminary	First Production	This datasheet contains preliminary data, and supplementary data will be published at a later date. Fairchild Semiconductor reserves the right to make changes at any time without notice in order to improve design.
No Identification Needed	Full Production	This datasheet contains final specifications. Fairchild Semiconductor reserves the right to make changes at any time without notice in order to improve design.
Obsolete	Not In Production	This datasheet contains specifications on a product that has been discontinued by Fairchild semiconductor. The datasheet is printed for reference information only.