



Is Now Part of



**ON Semiconductor®**

To learn more about ON Semiconductor, please visit our website at  
[www.onsemi.com](http://www.onsemi.com)

ON Semiconductor and the ON Semiconductor logo are trademarks of Semiconductor Components Industries, LLC dba ON Semiconductor or its subsidiaries in the United States and/or other countries. ON Semiconductor owns the rights to a number of patents, trademarks, copyrights, trade secrets, and other intellectual property. A listing of ON Semiconductor's product/patent coverage may be accessed at [www.onsemi.com/site/pdf/Patent-Marking.pdf](http://www.onsemi.com/site/pdf/Patent-Marking.pdf). ON Semiconductor reserves the right to make changes without further notice to any products herein. ON Semiconductor makes no warranty, representation or guarantee regarding the suitability of its products for any particular purpose, nor does ON Semiconductor assume any liability arising out of the application or use of any product or circuit, and specifically disclaims any and all liability, including without limitation special, consequential or incidental damages. Buyer is responsible for its products and applications using ON Semiconductor products, including compliance with all laws, regulations and safety requirements or standards, regardless of any support or applications information provided by ON Semiconductor. "Typical" parameters which may be provided in ON Semiconductor data sheets and/or specifications can and do vary in different applications and actual performance may vary over time. All operating parameters, including "Typicals" must be validated for each customer application by customer's technical experts. ON Semiconductor does not convey any license under its patent rights nor the rights of others. ON Semiconductor products are not designed, intended, or authorized for use as a critical component in life support systems or any FDA Class 3 medical devices or medical devices with a same or similar classification in a foreign jurisdiction or any devices intended for implantation in the human body. Should Buyer purchase or use ON Semiconductor products for any such unintended or unauthorized application, Buyer shall indemnify and hold ON Semiconductor and its officers, employees, subsidiaries, affiliates, and distributors harmless against all claims, costs, damages, and expenses, and reasonable attorney fees arising out of, directly or indirectly, any claim of personal injury or death associated with such unintended or unauthorized use, even if such claim alleges that ON Semiconductor was negligent regarding the design or manufacture of the part. ON Semiconductor is an Equal Opportunity/Affirmative Action Employer. This literature is subject to all applicable copyright laws and is not for resale in any manner.

User Guide for

# FEBFAN9611\_S01U300A Evaluation Board

FAN9611 300W Interleaved Dual-BCM,  
Low-Profile, PFC Evaluation Board

Featured Fairchild Product:  
FAN9611

***Direct questions or comments  
about this evaluation board to:  
“Worldwide Direct Support”***

***[Fairchild Semiconductor.com](http://Fairchild Semiconductor.com)***

## Table of Contents

1. Overview of the Evaluation Board.....	3
2. Key Features.....	5
3. Specifications.....	6
4. Test Procedure.....	7
4.1. Safety Precautions.....	7
5. Schematic.....	9
6. Boost Inductor Specification.....	10
7. Four-Layer PCB and Assembly Images.....	11
8. Bill of Materials (BOM).....	14
9. Inrush Current Limiting.....	16
10. Test Results.....	18
10.1. Startup.....	18
10.2. Steady State Operation.....	20
10.3. Line Transient.....	24
10.4. Load Transient.....	25
10.5. Brownout Protection.....	27
10.6. Phase Management.....	28
10.7. Efficiency.....	30
10.8. Harmonic Distortion and Power Factor.....	32
10.9. EMI.....	33
11. References.....	34
12. Ordering Information.....	34
13. Revision History.....	34

The following user guide supports the FAN9611 300W evaluation board for interleaved boundary-conduction-mode power-factor-corrected supply. It should be used in conjunction with the FAN9611 datasheet, Fairchild application note [AN-6086 —Design Considerations for Interleaved Boundary-Conduction Mode PFC Using FAN9611 / FAN9612](#) and FAN9611/12 PFC Excel®-based Design Tool.

## 1. Overview of the Evaluation Board

The FAN9611 interleaved, dual Boundary-Conduction-Mode (BCM), Power-Factor-Correction (PFC) controllers operate two parallel-connected boost power trains 180° out of phase. Interleaving extends the maximum practical power level of the control technique from about 300W to greater than 800W. Unlike the Continuous Conduction Mode (CCM) technique often used at higher power levels, BCM offers inherent zero-current switching of the boost diodes (no reverse-recovery losses), which permits the use of less expensive diodes without sacrificing efficiency. Furthermore, the input and output filters can be smaller due to ripple current cancellation between the power trains and doubling of effective switching frequency.

The advanced line feed-forward with peak detection circuit minimizes the output voltage variation during line transients. To guarantee stable operation with less switching loss at light load, the maximum switching frequency is clamped at 525kHz. Synchronization is maintained under all operating conditions.

Protection functions include output over-voltage, over-current, open-feedback, under-voltage lockout, brownout, and redundant latching over-voltage protection. FAN9611 is available in a lead-free, 16-lead, Small-Outline Integrated-Circuit (SOIC) package.

This FAN9611 evaluation board uses a four-layer Printed Circuit Board (PCB) designed for 300W (400V/0.75A) rated power. The maximum rated power is 350W and the Maximum On-Time (MOT) power limit is set to 360W. The FEBFAN9611\_S01U300A is optimized to demonstrate all the FAN9611 efficiency and protection features in a low-profile height form factor less than 18mm.

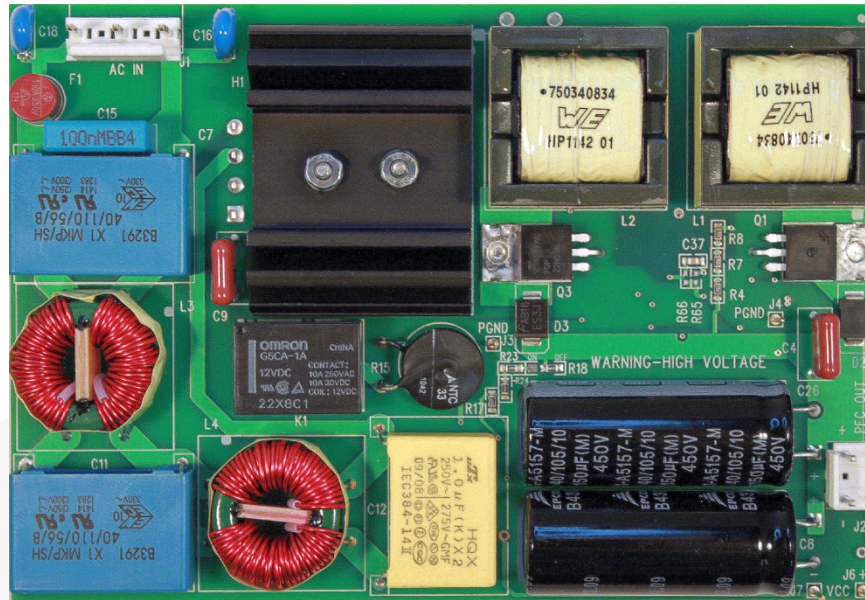


Figure 1. FEBFAN9611\_S01U300A, Top View, 152mm x 105mm



Figure 2. FEBFAN9611\_S01U300A, Side View (Low Profile), Cross Section=18mm

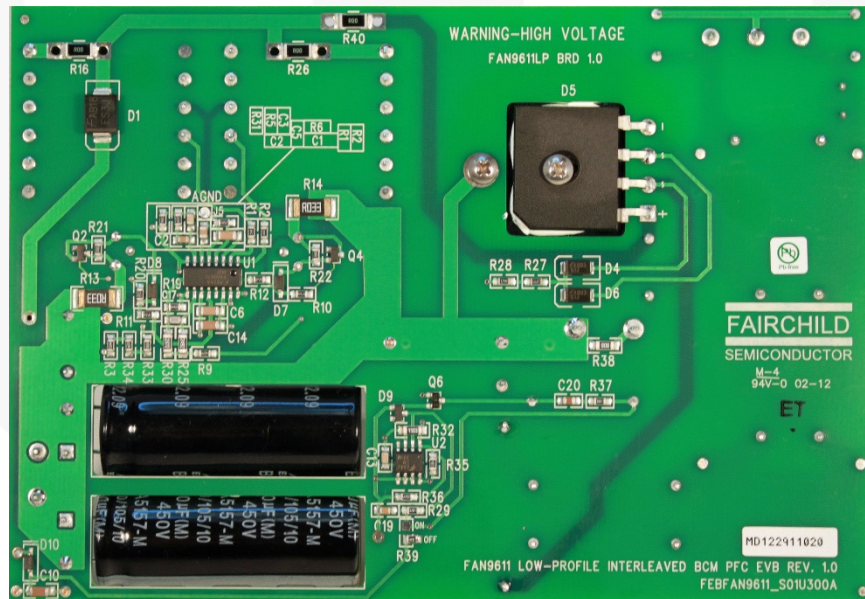


Figure 3. FEBFAN9611\_S01U300A, Bottom View, 152mm x 105mm

## 2. Key Features

- 180° Out-of-Phase Synchronization
- Automatic Phase Disable at Light Load
- 1.8A Sink, 1.0A Source, High-Current Gate Drivers
- Transconductance ( $g_m$ ) Error Amplifier for Reduced Overshoot
- Voltage-Mode Control with  $(V_{IN})^2$  Feed-Forward
- Closed-Loop Soft-Start with Programmable Soft-Start Time for Reduced Overshoot
- Minimum Restart Timer Frequency to Avoid Audible Noise
- Maximum Switching Frequency Clamp
- Brownout Protection with Soft Recovery
- Non-Latching OVP on FB Pin and Second-Level Latching Protection on OVP Pin
- Open-Feedback Protection
- Over-Current and Power-Limit Protection for Each Phase
- Low Startup Current: 80 $\mu$ A Typical
- Works with DC input or 50Hz to 400Hz AC Input

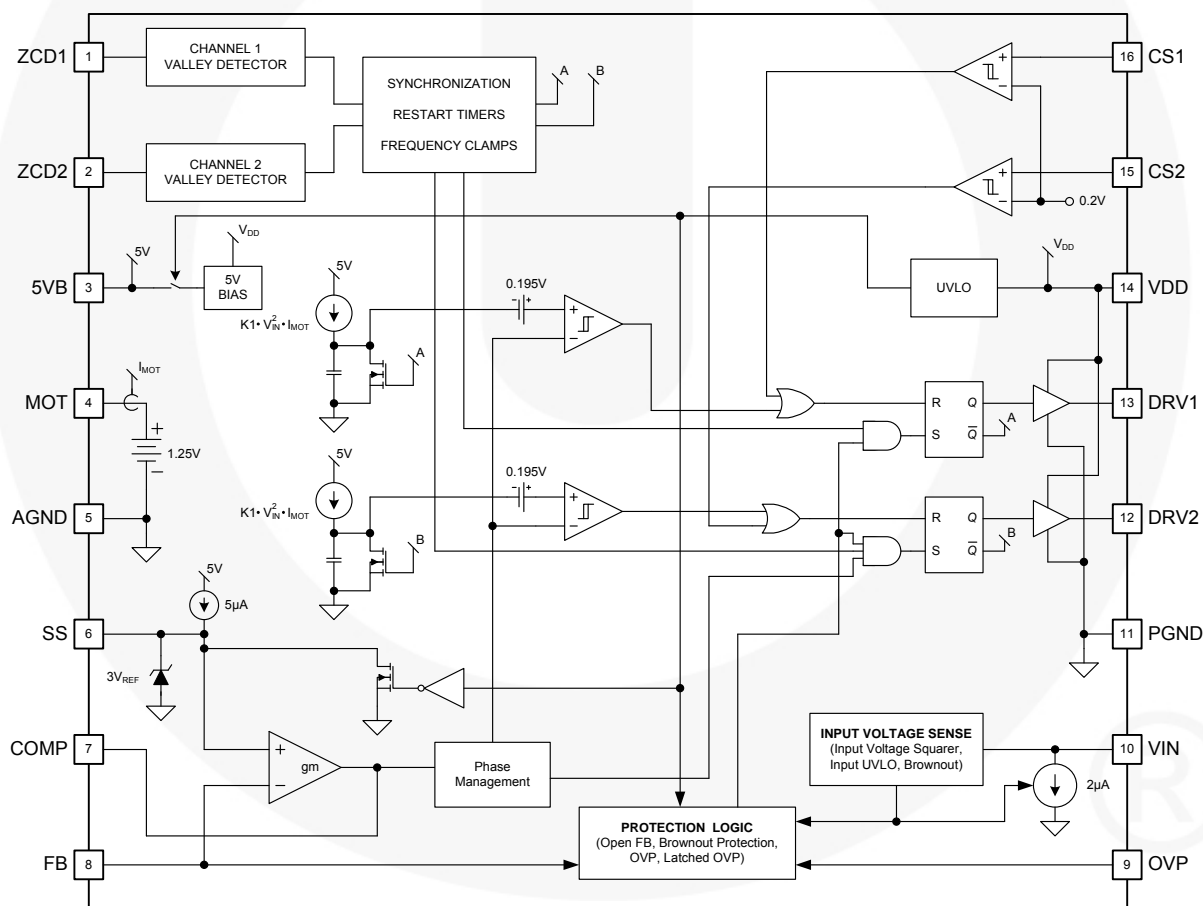


Figure 4. Block Diagram



### 3. Specifications

This evaluation board has been designed and optimized for the conditions in Table 1.

**Table 1. Electrical and Mechanical Requirements**

	<b>Min.</b>	<b>Typ.</b>	<b>Max.</b>
$V_{IN\_AC}$	80V	120V	265V
$V_{IN\_AC(ON)}$		90V	
$V_{IN\_AC(OFF)}$		80V	
$f_{VIN\_AC}$	50Hz	60Hz	65Hz
$V_{OUT\_PFC}$	395V	400V	405V
$V_{OUT\_PFC\_RIPPLE}$		10V	11V
$P_{OUT\_PFC}$		300W	350W
$P_{OUT\_PFC(MOT\ LIMIT)}$		360W	
$f_{SW\_PFC}$	18kHz		300kHz
$t_{HOLD\_UP}$	20ms		
$t_{SOFT\_START}$		250ms	300ms
$t_{ON\_OVERSHOOT}$			10V
$\eta_{PFC\_120V}$ $P_{OUT} > 30\% P_{OUT(TYP)}$		96%	96.5%
$\eta_{PFC\_230V}$ $P_{OUT} > 30\% P_{OUT(TYP)}$		95%	98%
$PF_{120V}$			0.991
$PF_{230V}$			0.980
<b>Mechanical and Thermal</b>			
Height			18mm
$\theta_{JC}$			60°C

The trip points for the built-in protections are set as below in the evaluation board.

- The line UVLO (brownout protection) trip point is set at  $80V_{AC}$  ( $10V_{AC}$  hysteresis).
- The pulse-by-pulse current limit for each MOSFET is set at 6A.

The current-limit function can be observed by measuring the individual inductor current waveforms while operating at  $85V_{AC}$  and increasing the load to 360W. The maximum power limit is set at ~120% of the rated output power. The power-limit function can be observed while operating at  $>115V_{AC}$  and increasing the load beyond 360W. When operating in power limit, the output voltage drops and the COMP voltage is saturated, but the AC line current remains sinusoidal. The phase-management function permits phase shedding / adding ~18% of the nominal output power for high line ( $230V_{AC}$ ). This level can be increased by modifying the MOT resistor (R6) as described in Fairchild Application Note [AN-6086 —Design Considerations for Interleaved Boundary-Conduction Mode PFC Using FAN9611 / FAN9612.](#)

## 4. Test Procedure

Before applying power to the FEBFAN9611\_S01U300A evaluation board; the DC bias supply for  $V_{DD}$ , AC voltage supply for line input, and DC electronic load for output should be connected to the board as shown in Figure 5.

**Table 2. Specification Excerpt from FAN9611 Datasheet**

Symbol	Parameter	Conditions	Min.	Typ.	Max.	Unit
<b>Supply</b>						
$I_{STARTUP}$	Startup Supply Current	$V_{DD} = V_{ON} - 0.2V$		80	110	$\mu A$
$I_{DD}$	Operating Current	Output Not Switching		3.7	5.2	mA
$I_{DD\_DYM}$	Dynamic Operating Current	$f_{SW} = 50kHz$ ; $C_{LOAD} = 2nF$		4	6	mA
$V_{ON}$	UVLO Start Threshold	$V_{DD}$ Increasing	9.5	10.0	10.5	V
$V_{OFF}$	UVLO Stop Threshold Voltage	$V_{DD}$ Decreasing	7.0	7.5	8.0	V
$V_{HYS}$	UVLO Hysteresis	$V_{ON} - V_{OFF}$		2.5		V

### 4.1. Safety Precautions



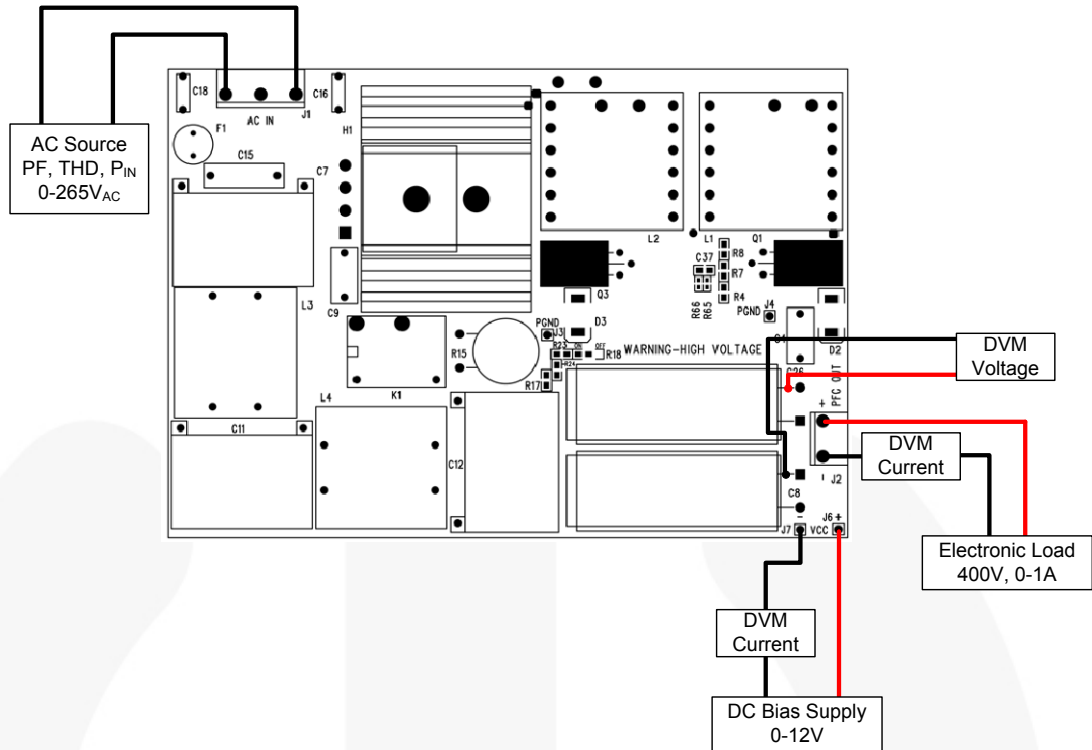
The FEBFAN9611\_S01U300A evaluation module produces lethal voltages and the bulk output capacitors store significant charge. Please be extra careful when probing and handling the module and observe a few precautions:

- Start with a clean working surface, clear of any conductive material.
- Be careful while turning on the power switch to the AC source.
- Never probe or move a probe on the DUT while the AC line voltage is present.
- Ensure the output capacitors are discharged before disconnecting the test leads. One way to do this is to remove the AC power with the DC output load still switched on. The load then discharges the output capacitors and the module is safe to disconnect.

#### Power-On Procedure

1. Supply  $V_{DD}$  for the control chip first. It should be higher than 10.5V (refer to the specification for  $V_{DD}$  turn-on threshold voltage in Table 2).
2. Connect the AC voltage (90~265V<sub>AC</sub>) to start the FAN9611 evaluation board. Since FAN9611 has brownout protection, any input voltage less than the designed minimum AC line voltage triggers brownout protection. FEBFAN9611\_S01U300A does not start until the AC input voltage is greater than 90V<sub>AC</sub>.
3. Change load current (0~0.75A) and check the operation
4. Verify the output voltage is regulating between 395V<sub>DC</sub> <  $V_{OUT}$  < 405V<sub>DC</sub>





**Figure 5. Recommended Test Set-Up**

All efficiency data shown in this document was taken using the test set up shown in Figure 5 with the output voltage being measured directly at the output bulk capacitors (not through the output connector (J2)).

#### Power-Off Procedure

1. Make sure the electronic load is set to draw at least 100mA of constant DC current.
2. Disconnect (shut down) AC line voltage source.
3. Disconnect (shut down) 12V DC bias power supply.
4. Disconnect (shut down) DC electronic load last to ensure that the output capacitors are fully discharged before handling the evaluation module.

## 5. Schematic

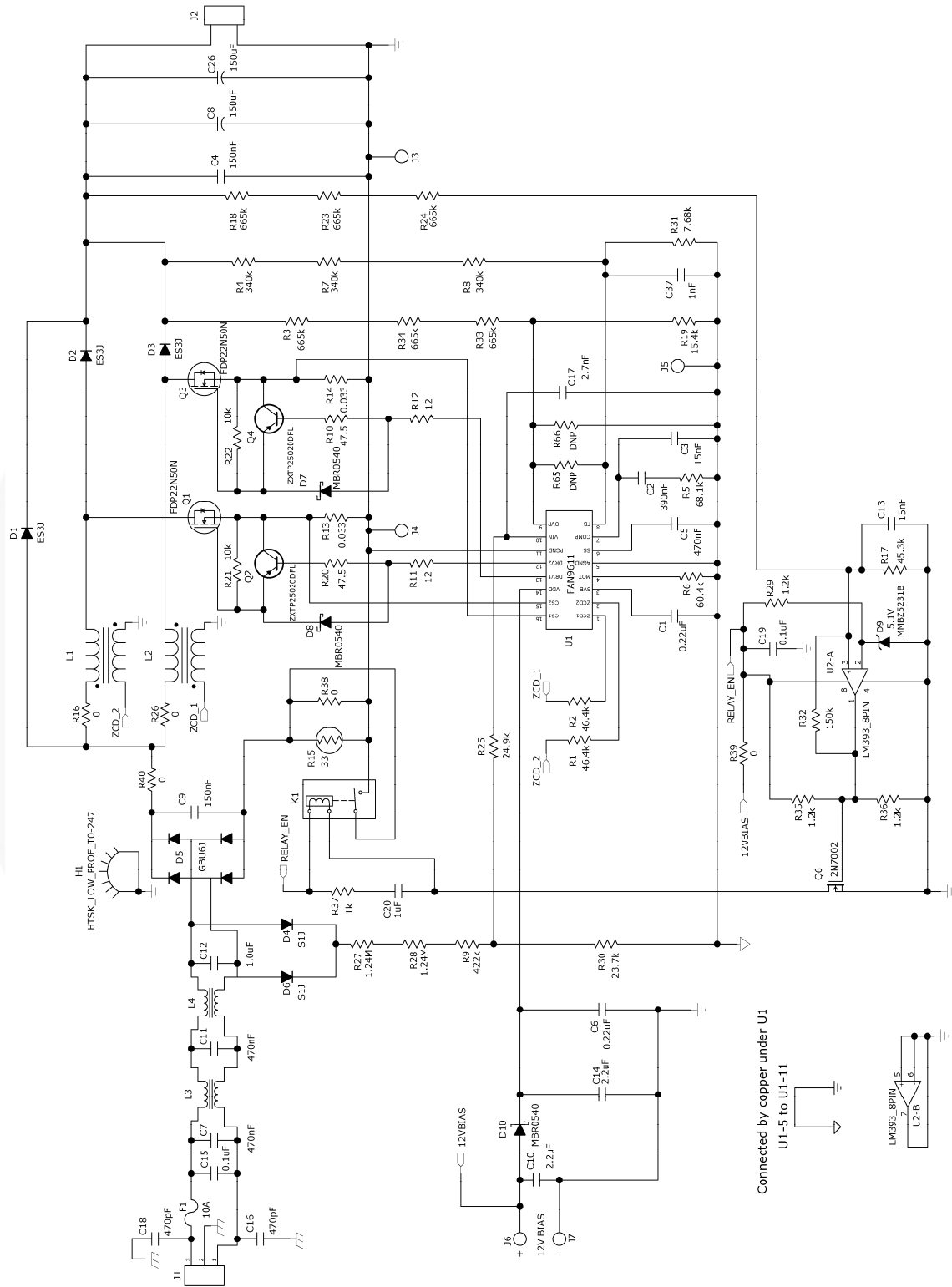


Figure 6. FEBFAN9611\_S01U300A 300W Evaluation Board Schematic

## 6. Boost Inductor Specification

750340834 from Wurth Electronics ([www.we-online.com](http://www.we-online.com))



- Core: EFD30 ( $A_c=69\text{mm}^2$ )
- Bobbin: EFD30
- Inductance :  $270\mu\text{H}$

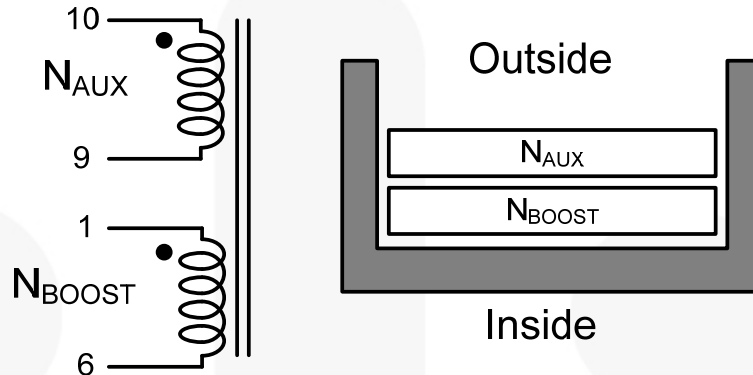


Figure 7. Boost Inductor (L1, L2) in the Evaluation Board

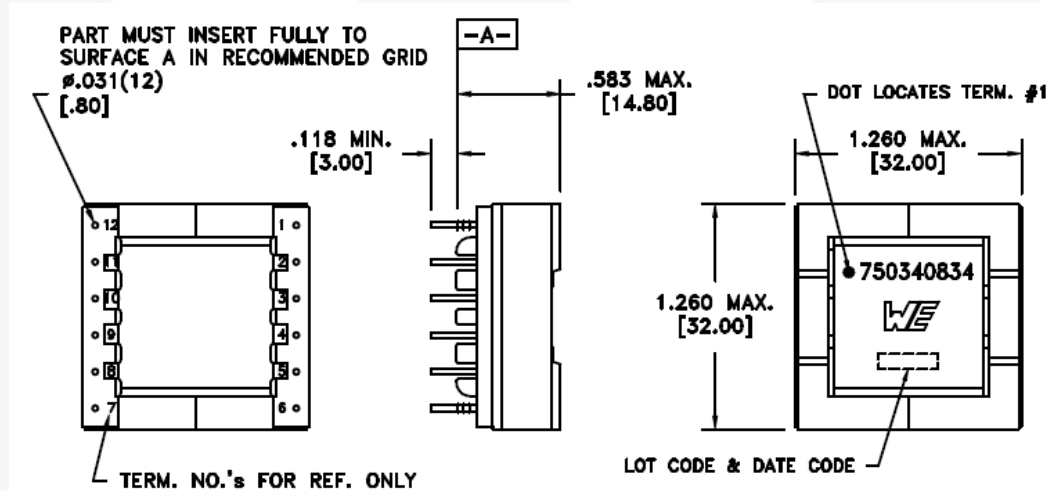


Figure 8. Wurth 750340834 Mechanical Drawing

Table 3. Inductor Turns Specifications

	Pin	Turns	Wire
$N_{\text{BOOST}}$	1 → 6	69 (3 Layers)	30xAWG#38 Litz
Insulation Tape			
$N_{\text{AUX}}$	10 → 9	7	AWG#28
Insulation Tape			

## 7. Four-Layer PCB and Assembly Images

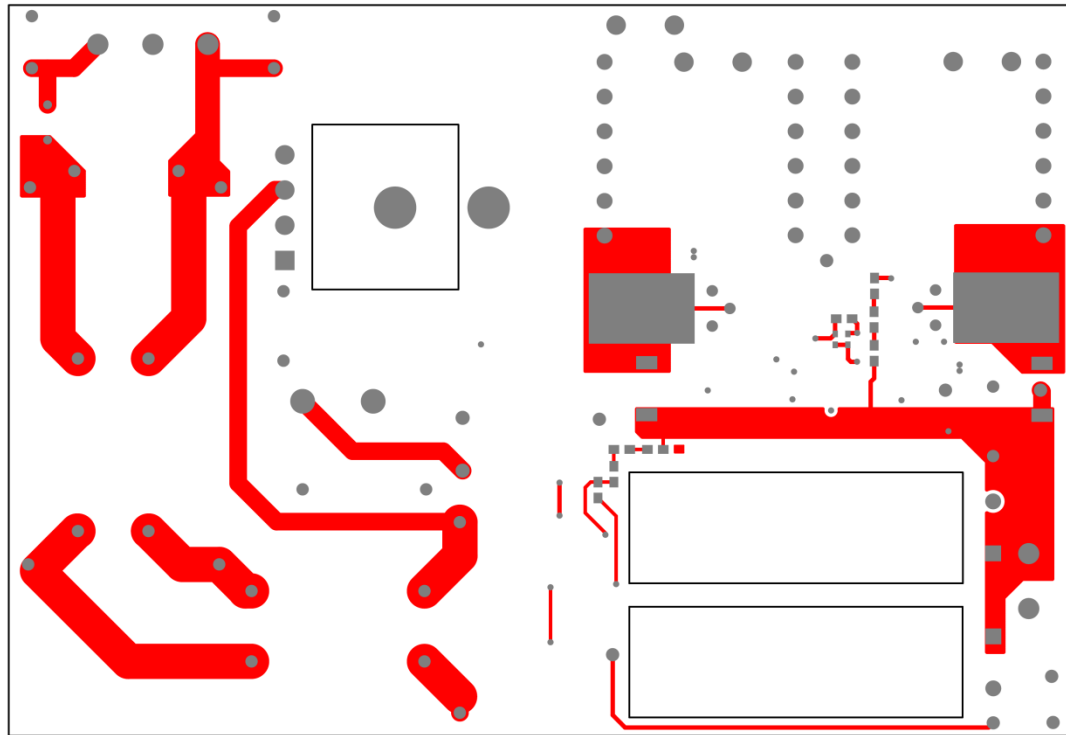


Figure 9. Layer 1 – Top Layer

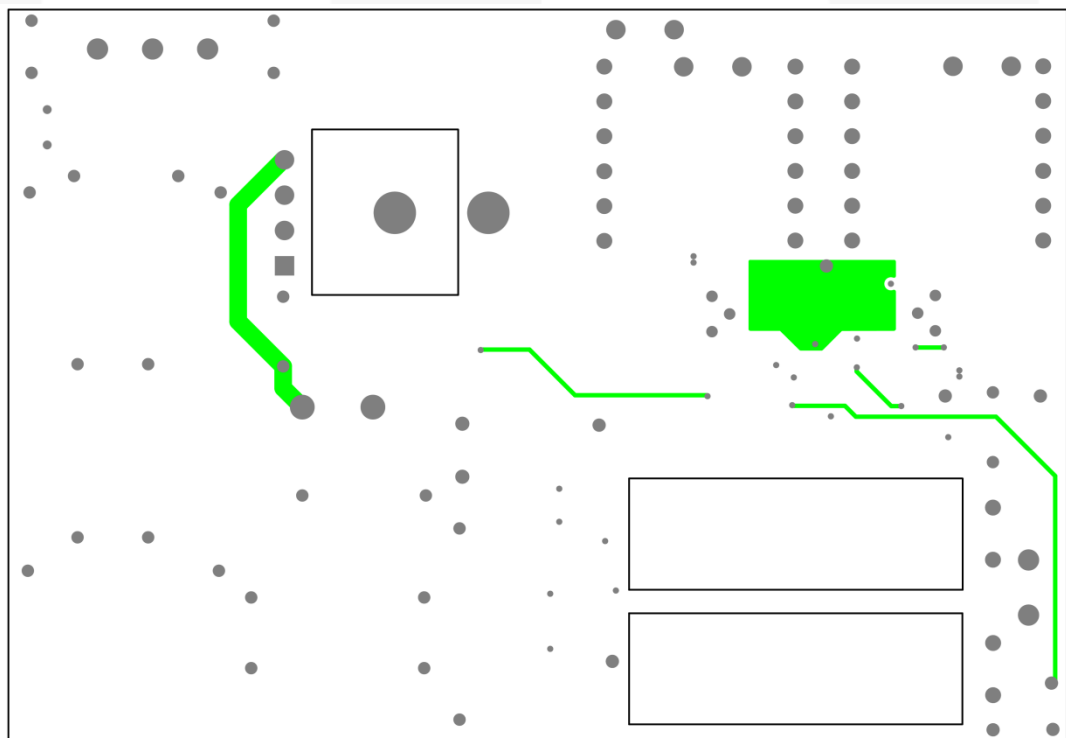


Figure 10. Layer 2 – Internal Layer

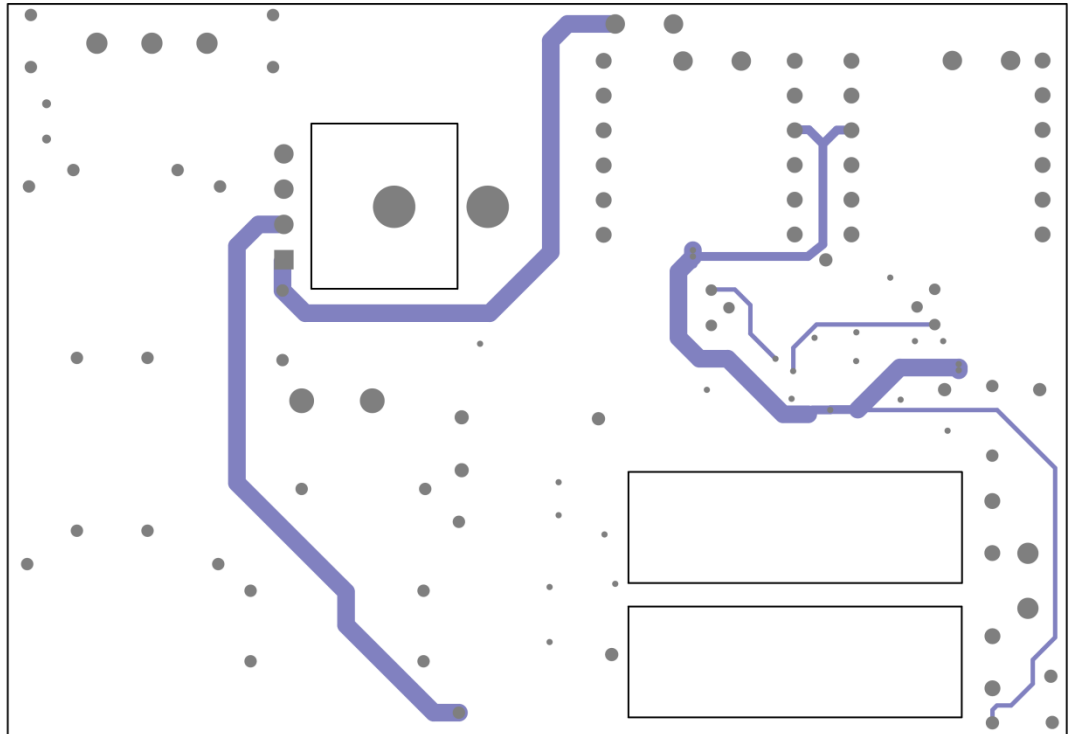


Figure 11. Layer 3 – Internal Layer

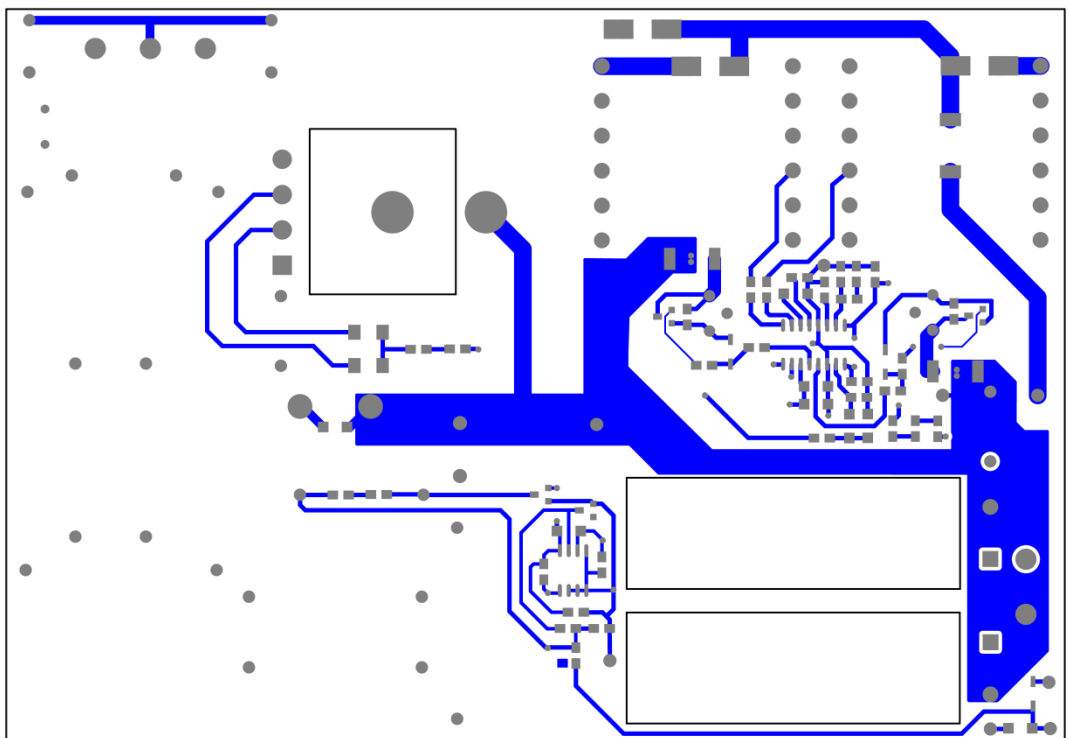


Figure 12. Layer 4 – Bottom Layer

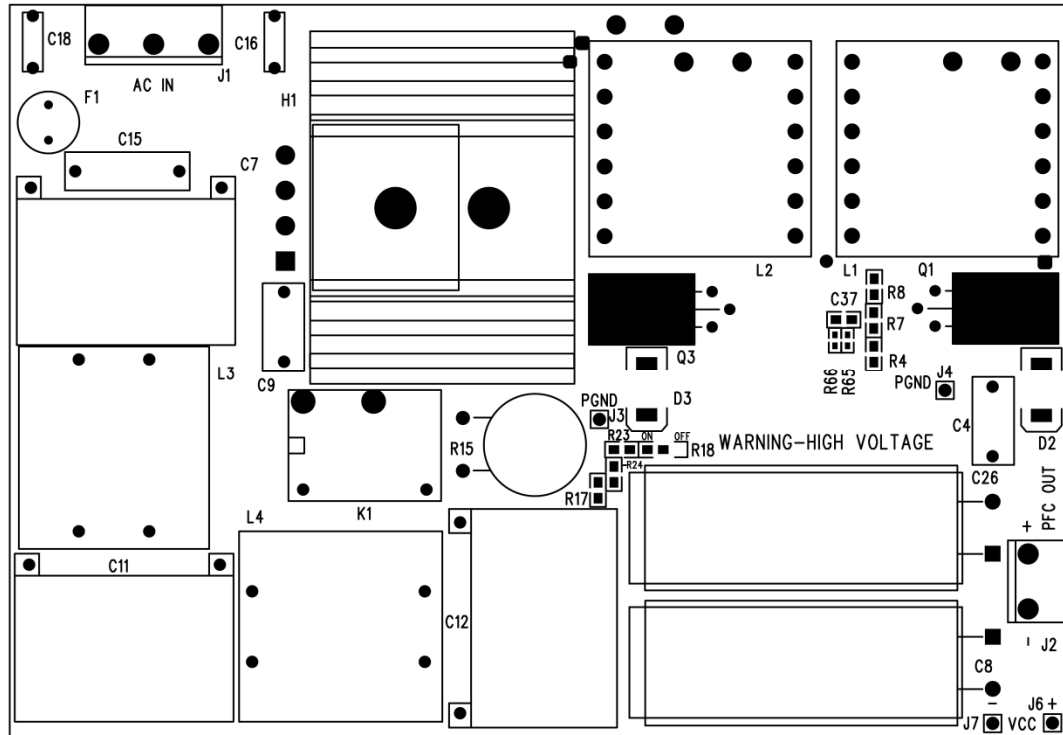


Figure 13. Top Assembly

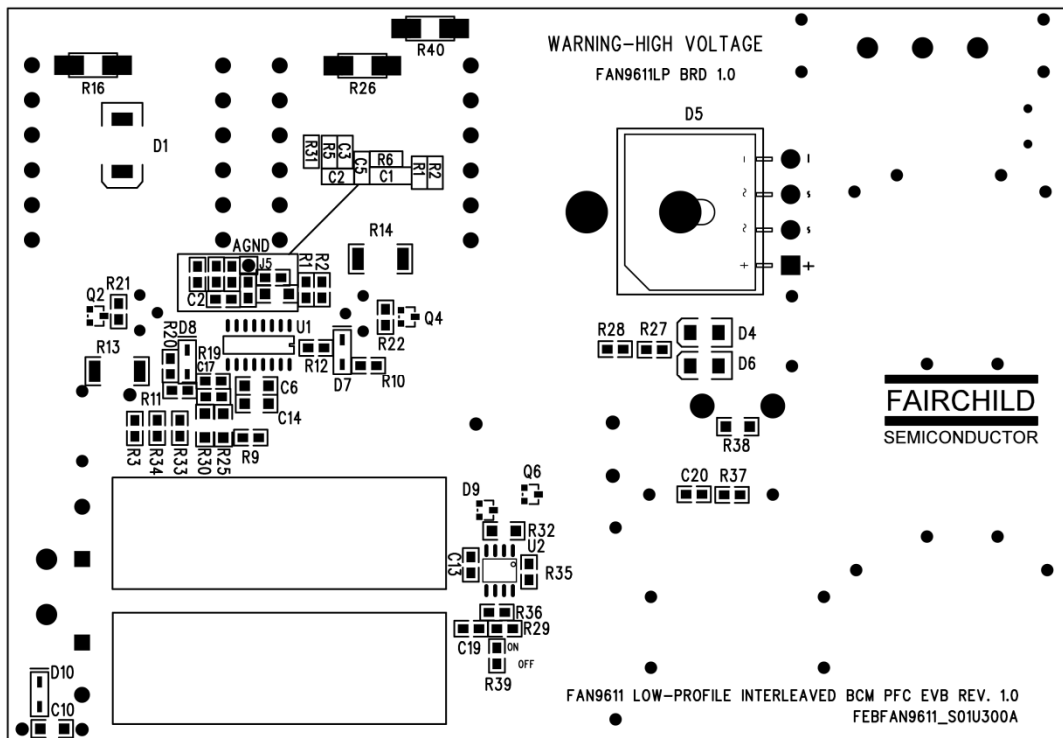


Figure 14. Bottom Assembly



## 8. Bill of Materials (BOM)

Item	Qty.	Reference	Part Number	Value	Description	Manufacturer	Package
1	2	C1, C6		0.22μF	CAP, SMD, Ceramic, 25V, X7R	STD	1206
2	1	C2		390nF	CAP, SMD, Ceramic, 25V, X7R	STD	805
3	2	C3, C13		15nF	CAP, SMD, Ceramic, 25V, X7R	STD	805
4	2	C4, C9	ECW-F2W154JAQ	150nF	Cap, 450V, 5%, Polypropylene	Panasonic	Thru-Hole
5	1	C5		470nF	CAP, SMD, Ceramic, 25V, X7R	STD	805
6	2	C7, C11	B32914A3474	470nF	Cap, 330VAC, 10%, Polypropylene	EPCOS	Thru-Hole
7	2	C8, C26	B43041A5157M	150μF	Cap, Alum, Elect.	EPCOS	Thru-Hole
8	2	C10, C14		2.2μF	CAP, SMD, Ceramic, 25V, X7R	STD	1206
9	1	C12	B32914A3105K	1μF	Cap, 330V <sub>AC</sub> , 10%, Polypropylene	Epcos	Thru-Hole
10	1	C15	PHE840MB6100MB05R17	0.1μF	Cap, X Type, 10%, Polypropylene	KEMET	Thru-Hole
11	2	C16, C18	CS85-B2GA471KYNS	470pF	Cap, Ceramic, 250V <sub>AC</sub> , 10%, Y5P,	TDK Corporation	Thru-Hole
12	1	C17		2.7nF	CAP, SMD, Ceramic, 25V, X7R	STD	805
13	1	C19		0.1μF	CAP, SMD, Ceramic, 25V, X7R	STD	805
14	1	C20		1μF	CAP, SMD, Ceramic, 50V, X5R	STD	805
15	1	C37		1nF	CAP, SMD, Ceramic, 25V, X7R	STD	805
16	3	D1-3	ES3J		Diode, 600V, 3A, Ultra-Fast Recovery	Fairchild Semiconductor	SMC
17	2	D4, D6	S1J		Diode, General Purpose, 1A, 600V	Fairchild Semiconductor	SMA
18	1	D5	GBU6J		Diode, Bridge, 6A, 1000V	Fairchild Semiconductor	Thru-Hole
19	3	D7-8, D10	MBR0540		Diode, Schottky, 40V, 500mA	Fairchild Semiconductor	SOD-123
20	1	D9	MMBZ5231B	5.1V	Diode, Zener, 5V, 350mW	Fairchild Semiconductor	SOT-23
21	1	F1	37421000410	10A	Fuse, 374 Series, 5.08mm Spacing	Littlefuse	Radial
22	1	H1	7-345-2PP-BA		Heatsink, Low Profile, T0-247	CTS	Thru-Hole
23	1	J1	1-1318301-3		Header, 3 Pin, 0.312 Spacing	TE Connectivity	Thru-Hole
24	1	J2	1-1123724-2		Header, 2 Pin, 0.312 Spacing	TYCO	Thru-Hole
25	5	J3-7	3103-2-00-21-00-00-08-0		Test pin, Gold, 40mil,	Mill-Max	Thru-Hole
26	1	K1	G5CA-1A DC12		RELAY PWR SPST-NO 10A 12VDC PCB	Omeron Electronics, Inc.	Thru-Hole
27	2	L1-2	750340834/NP1138-01	280μH	Inductor, Coupled	Würth	Thru-Hole
28	2	L3-4	750311795	9mH	Common Mode Choke, 9mH	Würth	Thru-Hole
29	2	Q1, Q3	FDP22N50N		MOSFET, NCH, UniFET, 500V, 11.5A, 0.18Ω	Fairchild Semiconductor	TO-220

Continued on the following page...

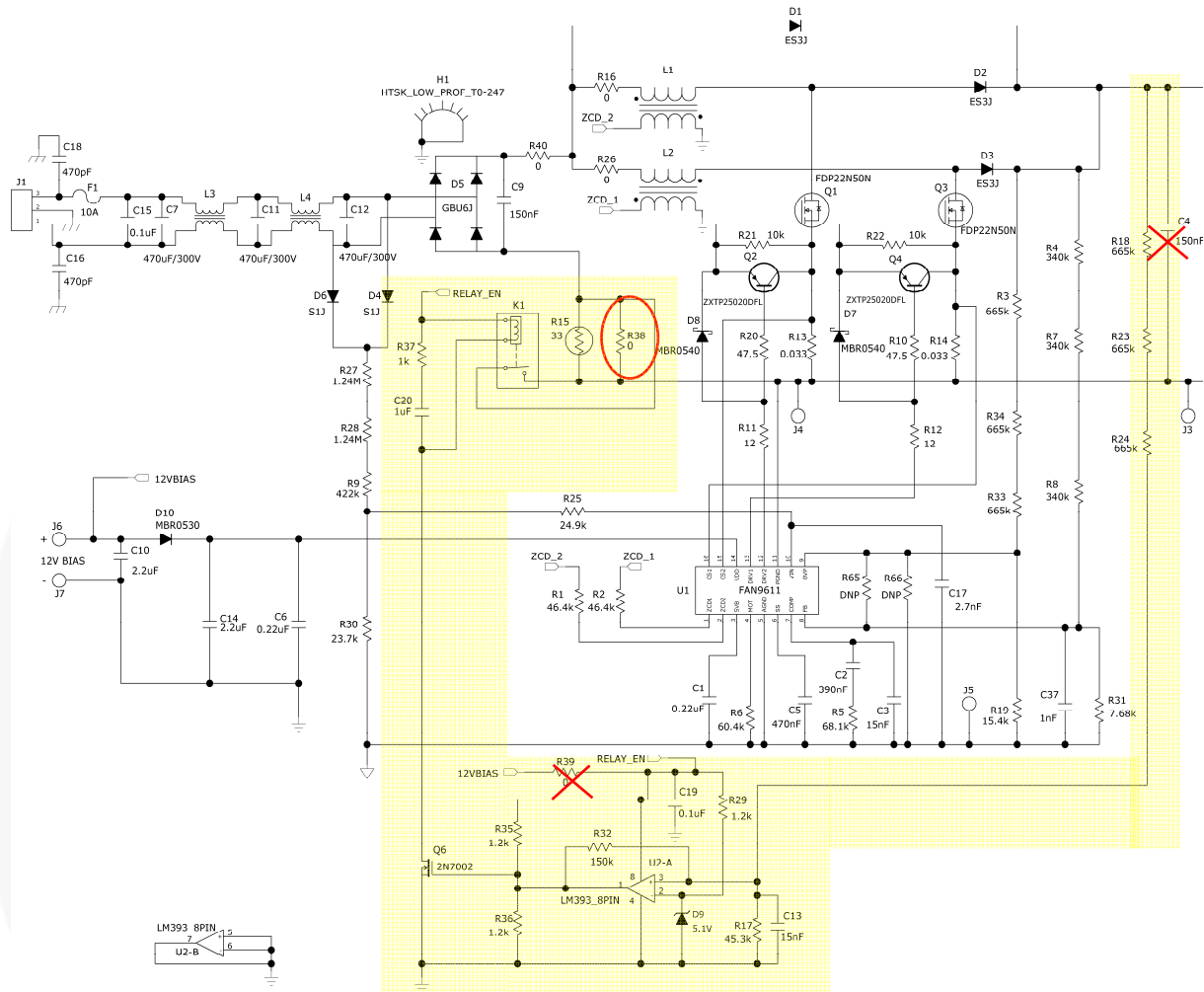
Item	Qty.	Reference	Part Number	Value	Description	Manufacturer	Package
30	2	Q2, Q4	ZXTP25020DFL		Transistor, PNP, 20V, 1.5A	Zetex	SOT-23
31	1	Q6	2N7002		MOSFET, NCH, 60V, 300mA	Philips	SOT-23
32	2	R1-2		46.4kΩ	RES, SMD, 1/8W	STD	805
33	6	R3, R18, R23-24 R33- 34		665kΩ	RES, SMD, 1/8W	STD	805
34	3	R4, R7-8		340kΩ	RES, SMD, 1/8W	STD	805
35	1	R5		68.1kΩ	RES, SMD, 1/8W	STD	805
36	1	R6		60.4kΩ	RES, SMD, 1/8W	STD	805
37	1	R9		422kΩ	RES, SMD, 1/8W	STD	805
38	2	R10, R20		47.5Ω	RES, SMD, 1/8W	STD	805
39	2	R11-12		12Ω	RES, SMD, 1/8W	STD	805
40	2	R13-14		0.033Ω	RES, SMD, 1W	STD	2512
41	1	R15	B57237S0330M000	33Ω	Thermistor	Epcos Inc.	Thru-Hole
42	3	R16, R26, R40		0Ω	RES, SMD, 1/2W	STD	2010
43	1	R17		45.3kΩ	RES, SMD, 1/8W	STD	805
44	1	R19		15.4kΩ	RES, SMD, 1/8W	STD	805
45	2	R21-22		10kΩ	RES, SMD, 1/8W	STD	805
46	1	R25		24.9kΩ	RES, SMD, 1/4W	STD	1206
47	2	R27-28		1.24MΩ	RES, SMD, 1/8W	STD	805
48	3	R29, R35-36		1.2kΩ	RES, SMD, 1/8W	STD	805
49	1	R30		23.7kΩ	RES, SMD, 1/4W	STD	1206
50	1	R31		7.68kΩ	RES, SMD, 1/8W	STD	805
51	1	R32		150kΩ	RES, SMD, 1/4W	STD	1206
52	1	R37		1kΩ	RES, SMD, 1/8W	STD	805
53	1	R38		0Ω	RES, SMD, 1/4W	STD	1206
54	1	R39		0Ω	RES, SMD, 1/8W	STD	805
55	2	R65-66		DNP	RES, SMD, 1/10W	STD	603
56	1	U1	FAN9611		Interleaved, Dual, BMC, PFC Controller	Fairchild Semiconductor	SOIC-16
57	1	U2	LM393M		Dual, Differential Comparator	Fairchild Semiconductor	SOIC-8
58	2	SC1, SC2	PMSSS 440 0050 PH		SCREW MACHINE PHIL 4-40X1/2 SS	STD	Hardware
59	2	W1, W2	INT LWZ 004		WASHER LOCK INT TOOTH #4 ZINC	STD	Hardware
60	2	N1, N2	HNZ440		NUT HEX 4-40 ZINC PLATED	STD	Hardware
61	1	PWB			4 Layer, FR4, FAN9611 LOW-PROFILE PWB - REV. 1.0	Fairchild Semiconductor	PCB

**Notes:**

1. DNP = Do Not Populate
2. STD = Standard Components

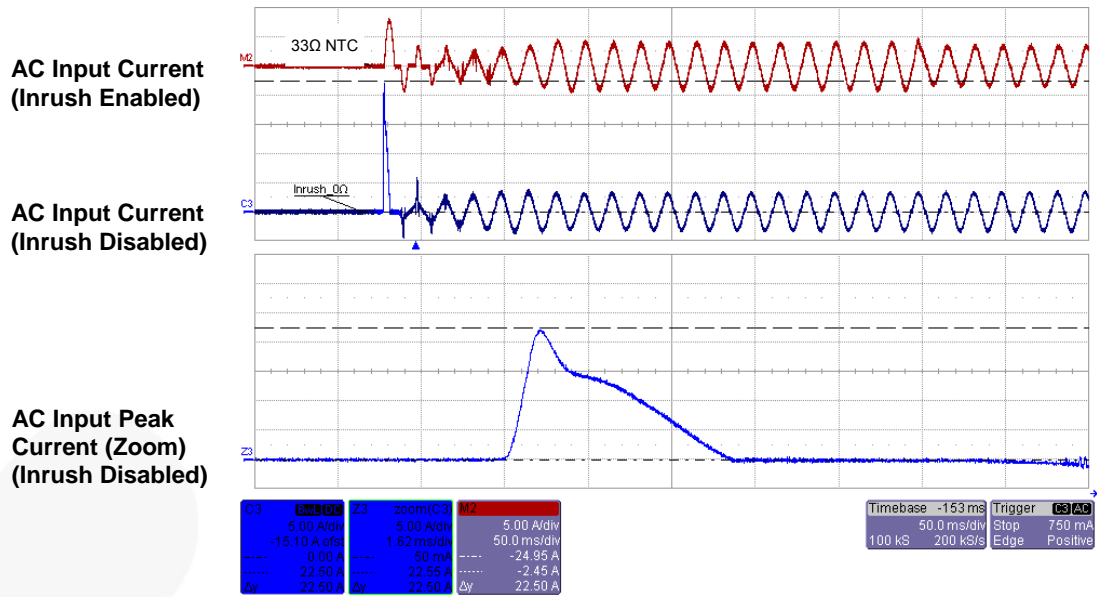
## 9. Inrush Current Limiting

The evaluation board includes an inrush current limiting circuit comprised of the highlighted components shown in Figure 15.



**Figure 15. Inrush Current Limiting Circuit**

Since the inrush current limiting circuit has a negative impact on light-load efficiency and may not be required by all offline applications, the evaluation board is configured with the inrush circuit fully populated, but disabled, as shown in Figure 15. R18 and R39 are installed on the PCB; purposely electrically open. To enable and test the inrush current limiting circuit, rotate R18 and R39 to complete the proper series connection shown in the schematic. Remove R38 to allow the 33Ω NTC thermistor (R15) to limit the inrush current during startup. Input current measurements can be made by removing the R16, 0Ω jumper and installing a loop of wire connected to the holes provided within the R16 PCB pad locations. A current probe can then be connected to the wire loop. The effectiveness of the inrush current limiting function is shown below in Figure 16.



M2: AC Line Current (5A/div), CH3: AC Line Current (5A/div), Time (50ms/div)

Figure 16. Full-Load Startup at 115V<sub>AC</sub>

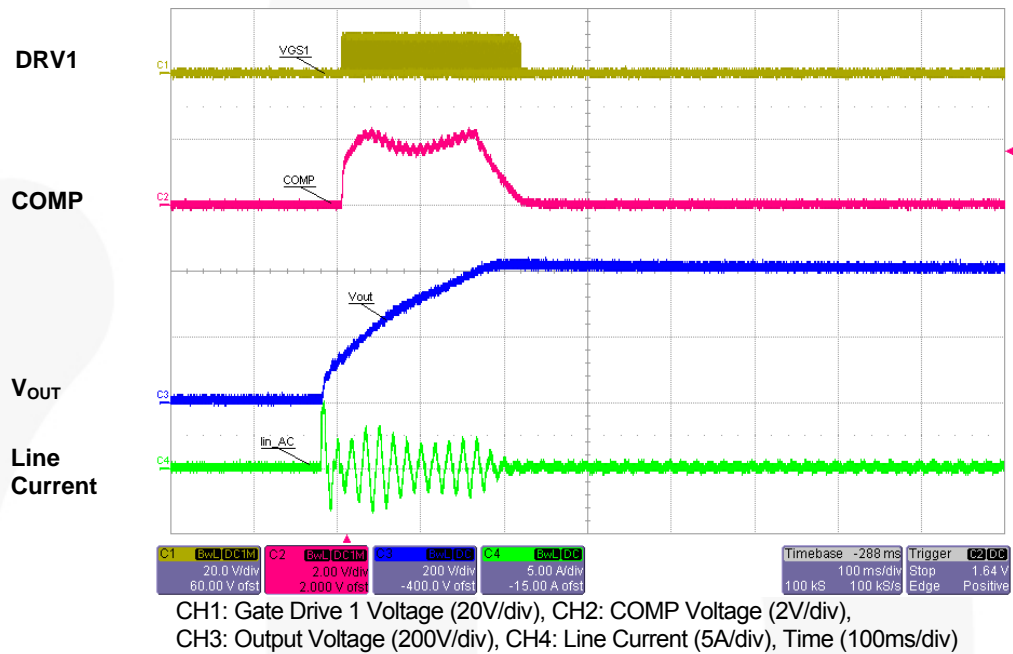
Table 4. Inrush Current Limiting Circuit Effectiveness Comparison

Input Line Voltage	Output Power	Peak Line Current (Inrush Circuit Disabled)	Peak Line Current (Inrush Circuit Enabled)	% Inrush Current Reduction
V <sub>IN</sub> =115V <sub>AC</sub>	300W	22.50A <sub>PK</sub>	8.45A <sub>PK</sub>	62.40%
V <sub>IN</sub> =230V <sub>AC</sub>	300W	26.9A <sub>PK</sub>	11.5A <sub>PK</sub>	57.3%

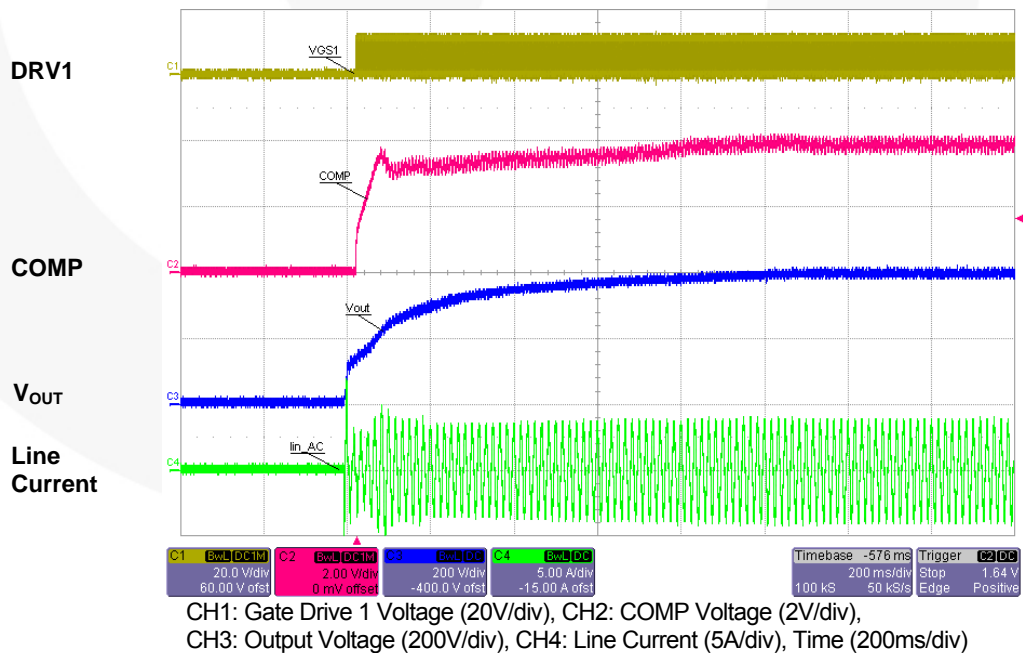
## 10. Test Results

### 10.1. Startup

Figure 17 and Figure 18 show the startup operation at 115V<sub>AC</sub> line voltage for no-load and full-load condition, respectively. Due to the closed-loop soft-start, almost no overshoot is observed for no-load startup and full-load startup.

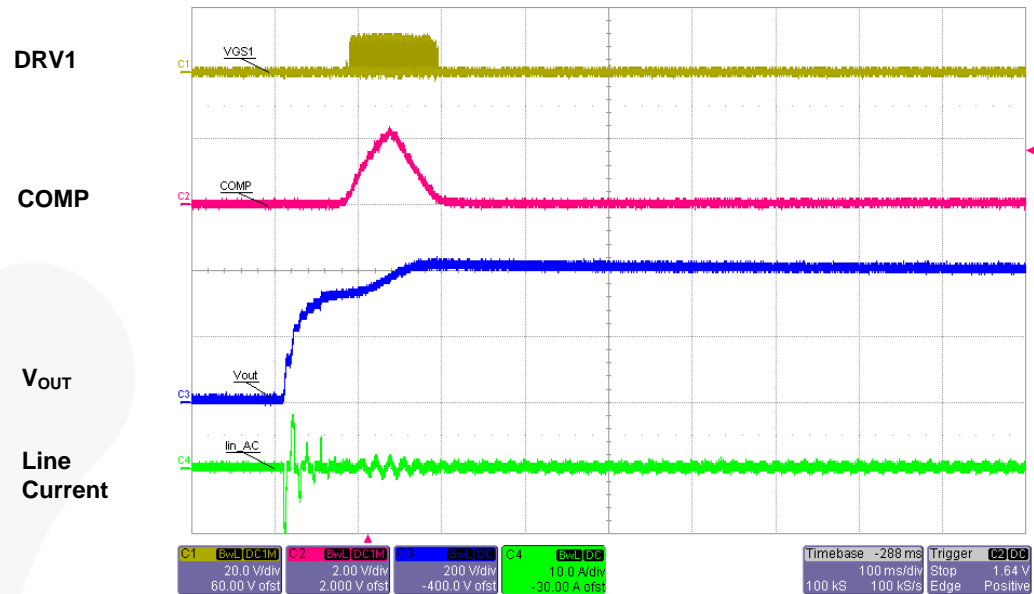


**Figure 17. No-Load Startup at 115V<sub>AC</sub>**

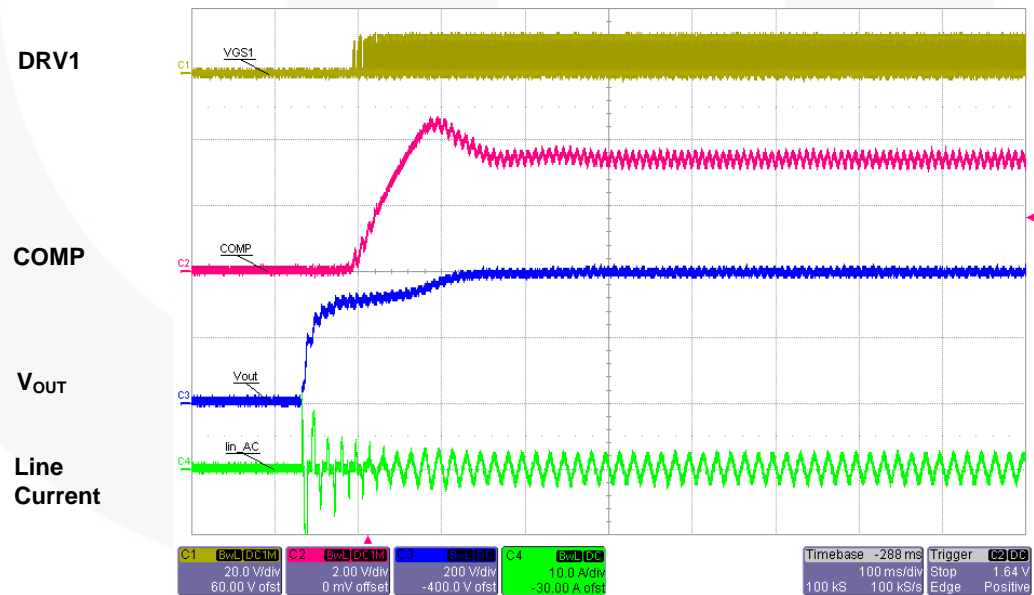


**Figure 18. Full-Load Startup at 115V<sub>AC</sub>**

Figure 19 and Figure 20 show the startup operation at 230V<sub>AC</sub> line voltage for no-load and full-load conditions, respectively. Due to the closed-loop soft-start, almost no overshoot is observed for no-load startup and full-load startup.



**Figure 19. No-Load Startup at 230V<sub>AC</sub>**



**Figure 20. Full-Load Startup at 230V<sub>AC</sub>**



## 10.2. Steady-State Operation

Figure 21 and Figure 22 show the two inductor currents and the sum of the two inductor currents operating at full load for 90V<sub>AC</sub> and 230V<sub>AC</sub> line voltage. The sum of the inductor currents has relatively small ripple due to the ripple cancellation of interleaving.

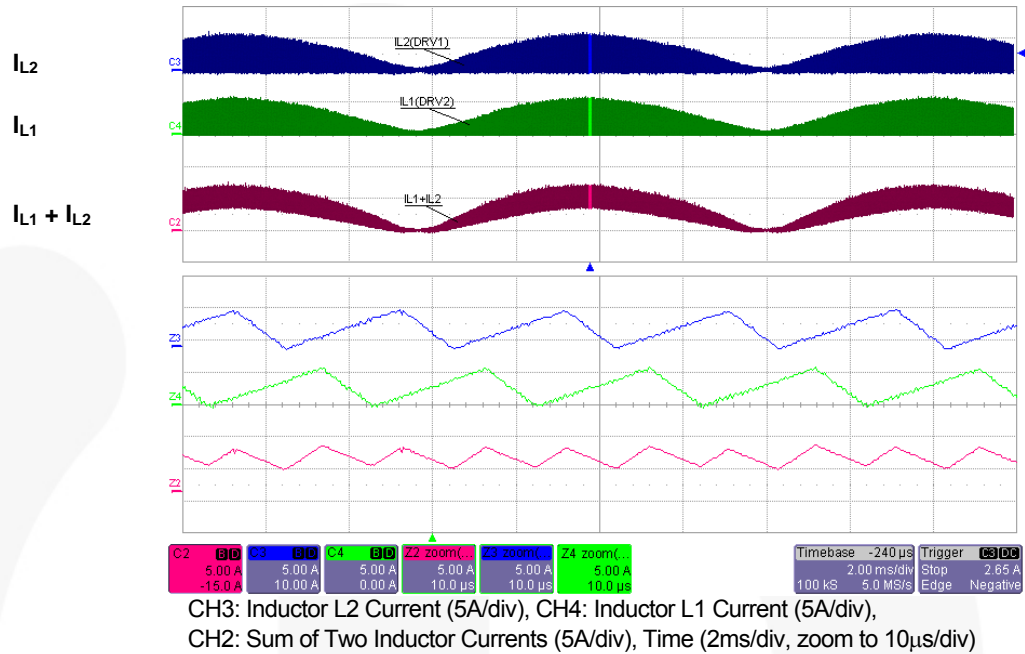


Figure 21. Zoom of Inductor Current Waveforms at Full-Load and 90V<sub>AC</sub>

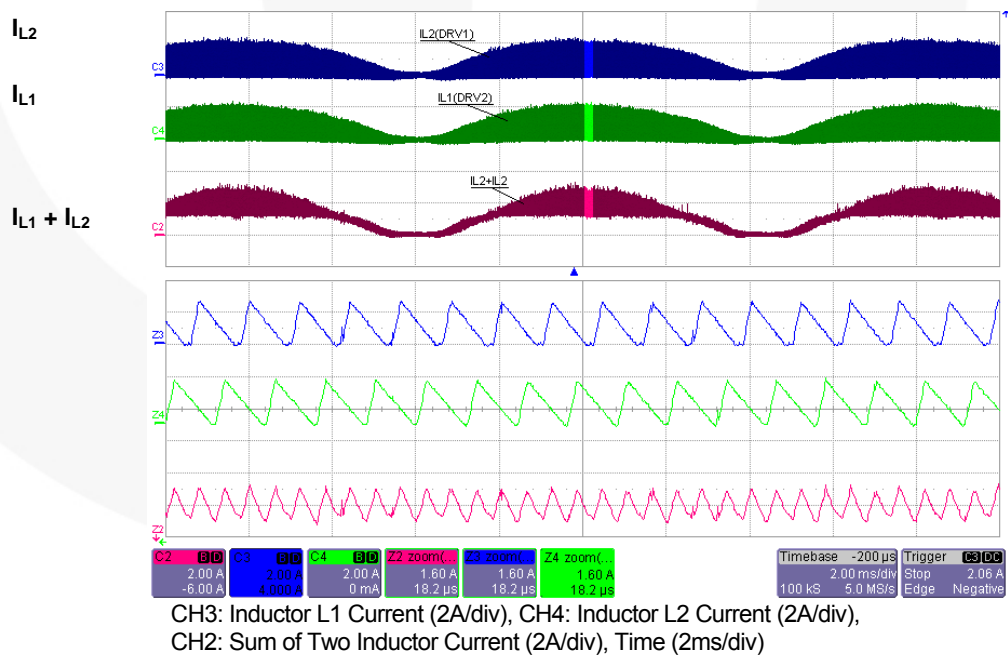
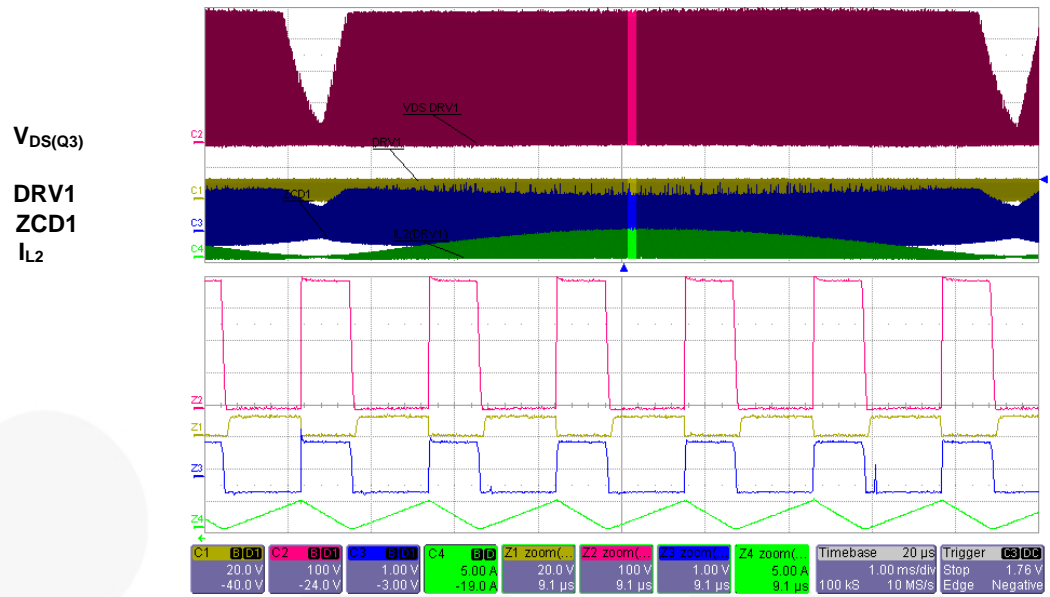
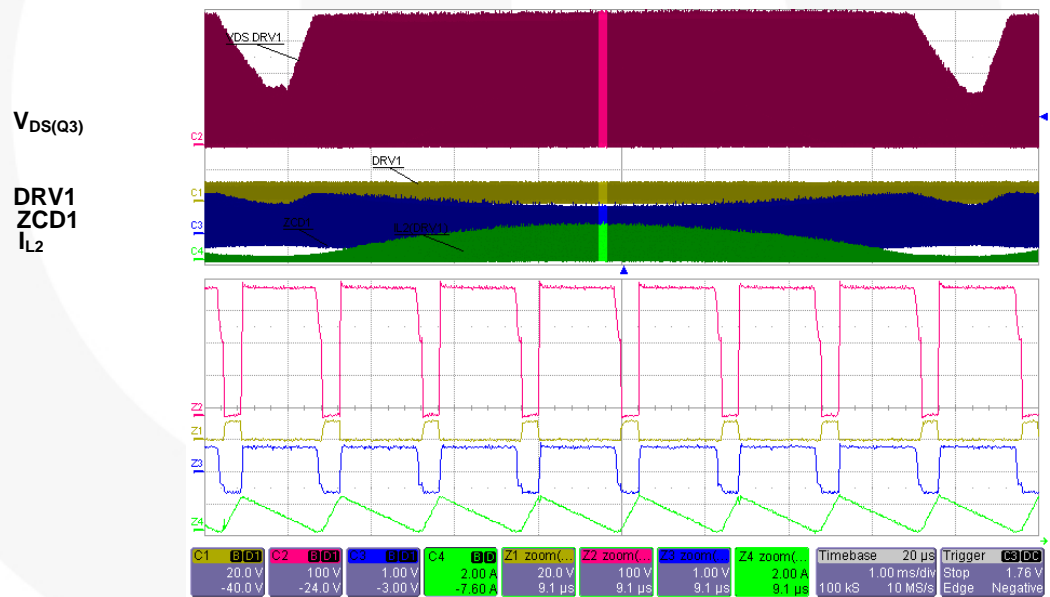


Figure 22. Zoom of Inductor Current Waveforms at Full-Load and 230V<sub>AC</sub>



CH1: DRV1 (20V/div), CH2: VDS(Q3) (100V/div)  
CH3: ZCD1 (1V/div), CH4: Inductor L2 Current (5A/div)

Figure 23. Zero Valley Switching at Full Load, 115V<sub>AC</sub>



CH1: DRV1 (20V/div), CH2: VDS(Q3) (100V/div)  
CH3: ZCD1 (1V/div), CH4: Inductor L2 Current (5A/div)

Figure 24. Zero Valley Switching at Full Load, 230V<sub>AC</sub>

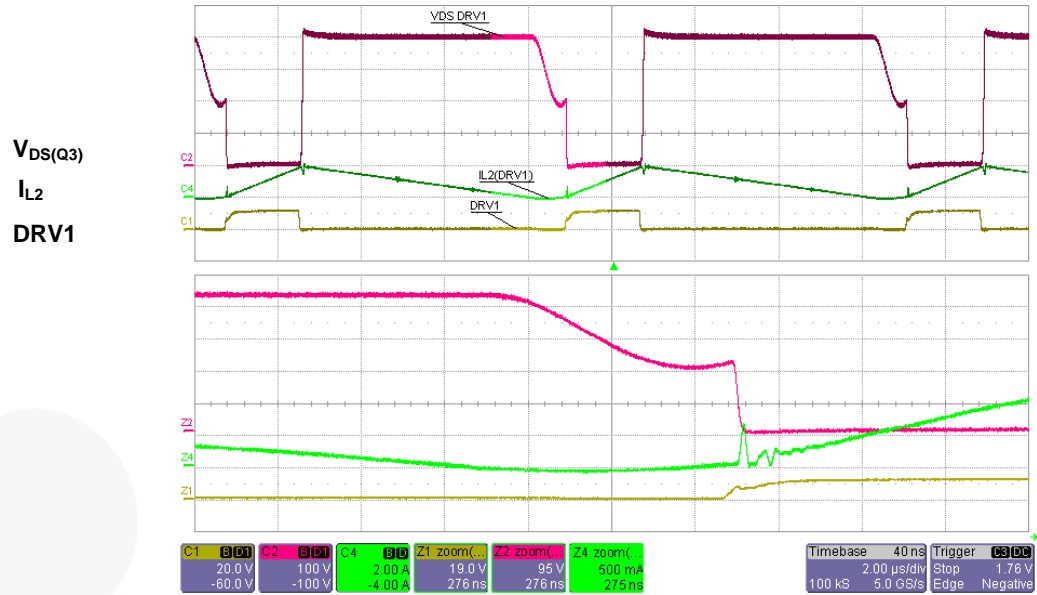


Figure 25. Zoom of Valley Switching at Full Load, 230V<sub>AC</sub>

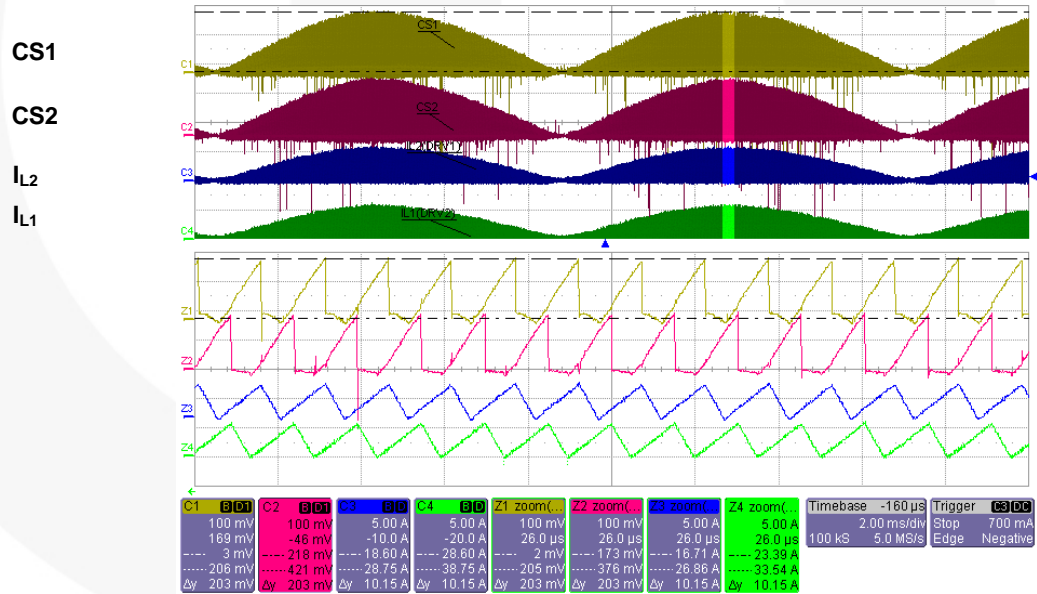
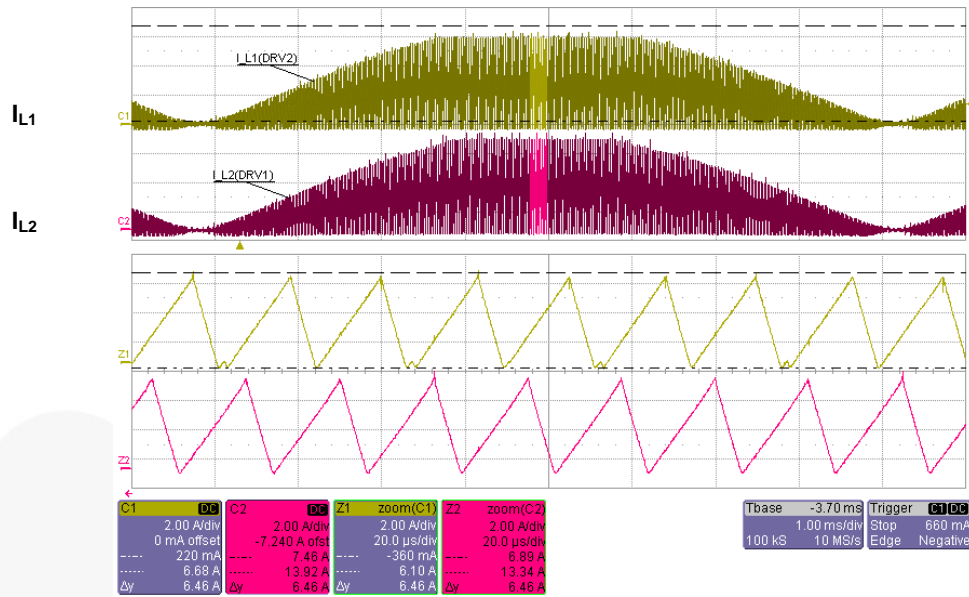
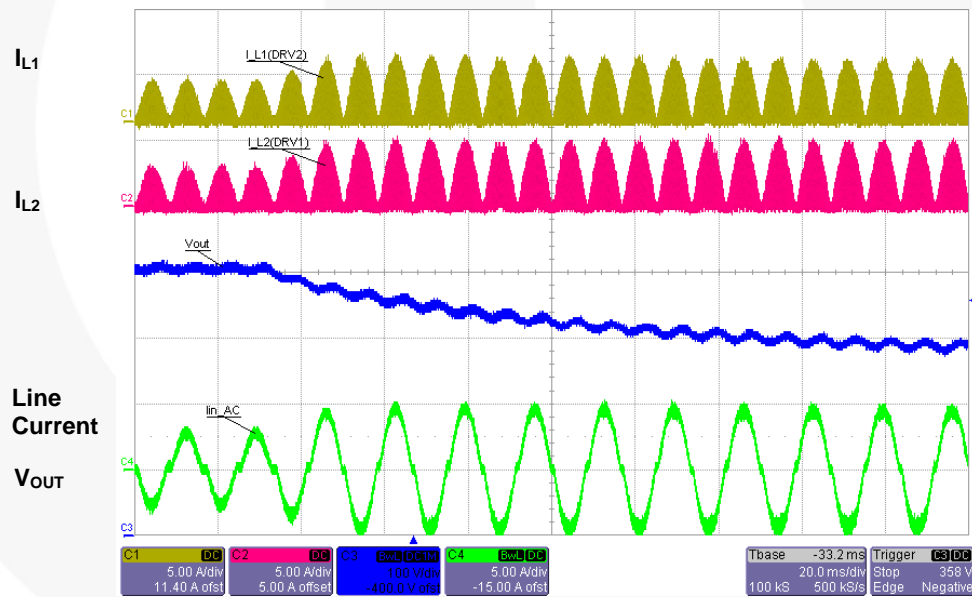


Figure 26. Current-Sense Waveforms at Full Load, 90V<sub>AC</sub>



CH1: Inductor L1 Current (2A/div), CH2: Inductor L2 Current (2A/div)

**Figure 27. Inductor Current Waveforms at 360W, 85V<sub>AC</sub>, Over-Current Operation**



CH1: Inductor L1 Current (5A/div), CH2: Inductor L2 Current (5A/div)  
CH3: Output Voltage (100V/div), CH4: Line Current (5A/div), Time (20ms/div)

**Figure 28. MOT Power Limit, 0.5A to 1.3A Load Transient, 115V<sub>AC</sub>**

### 10.3. Line Transient

Figure 29 and Figure 30 show the line transient operation and minimal effect on output voltage due to the line feed-forward function. When the line voltage changes from 230V<sub>AC</sub> to 115V<sub>AC</sub>, about 20V (5% of nominal output voltage) voltage undershoot is observed. When the line voltage changes from 115V<sub>AC</sub> to 230V<sub>AC</sub>, about 6V (1.5% of nominal output voltage) voltage overshoot is observed.

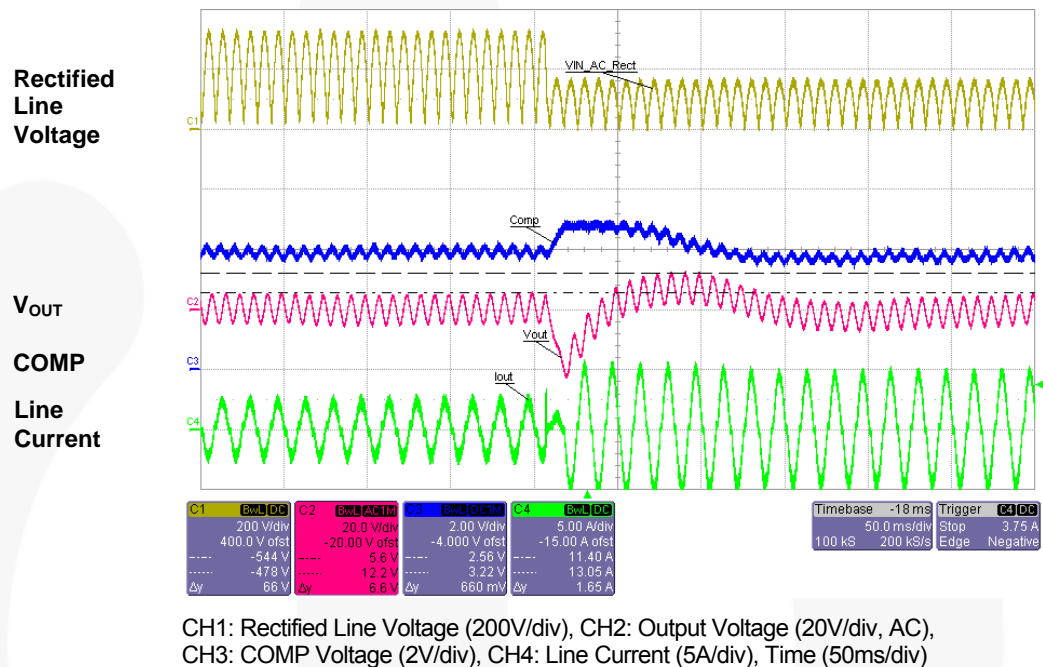


Figure 29. Line Transient Response at Full-Load Condition (230V<sub>AC</sub> → 115V<sub>AC</sub>)

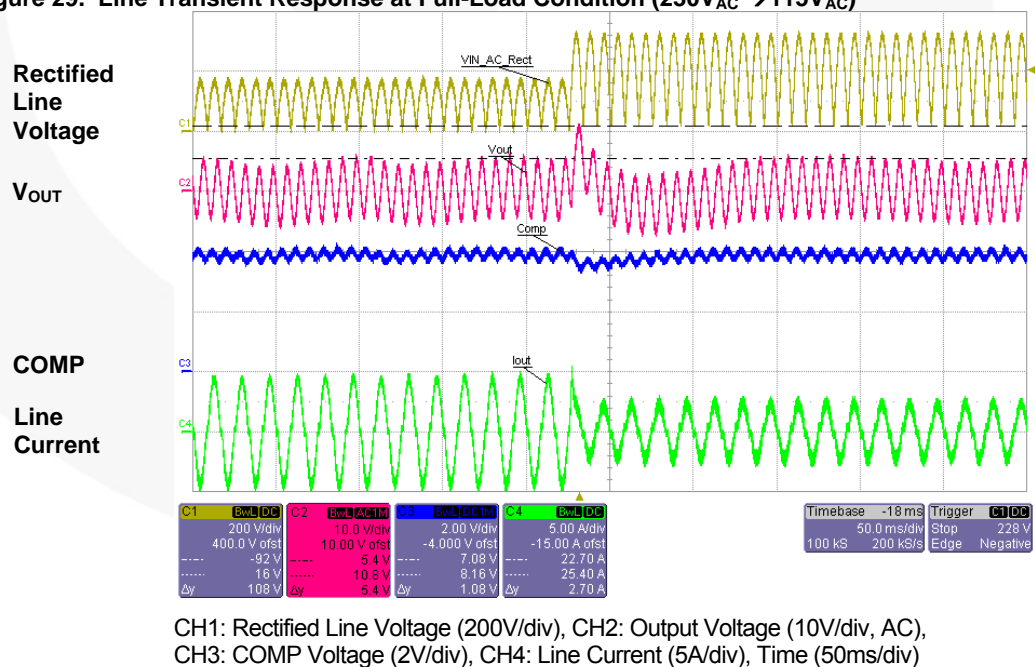
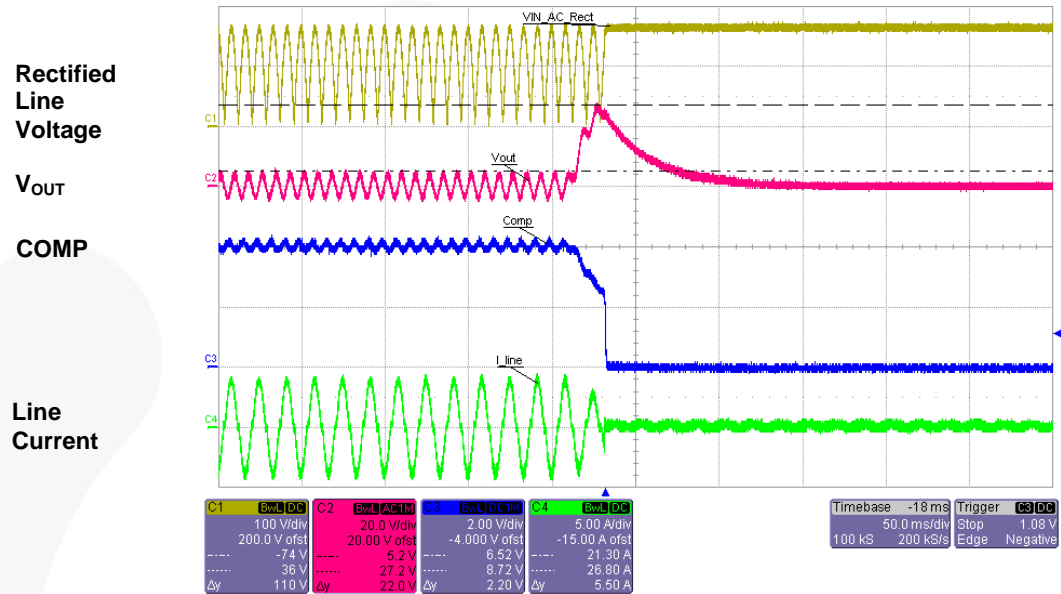


Figure 30. Line Transient Response at Full-Load Condition (115V<sub>AC</sub> → 230V<sub>AC</sub>)

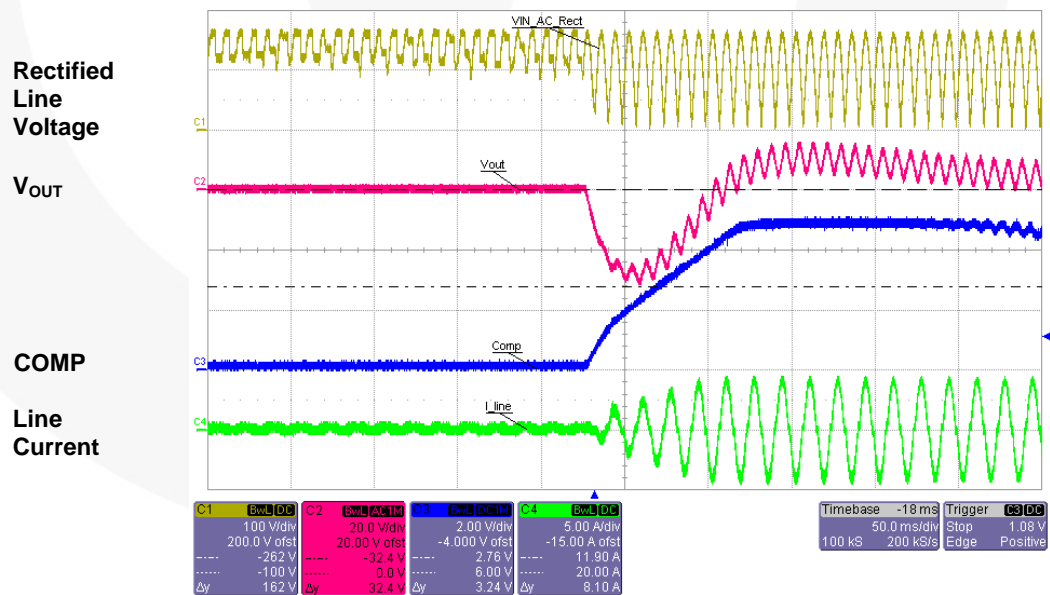
## 10.4. Load Transient

Figure 31 and Figure 32 show the load-transient operation. When the output load changes from 100% to 0%, 20V (5% of nominal output voltage) voltage overshoot is observed. When the output load changes from 0% to 100%, 34V (8.5% of nominal output voltage) voltage undershoot is observed.



CH1: Rectified Line Voltage (100V/div), CH2: Output Voltage (20V/div, AC), CH3: COMP Voltage (2V/div), CH4: Line Current (5A/div), Time (50ms/div)

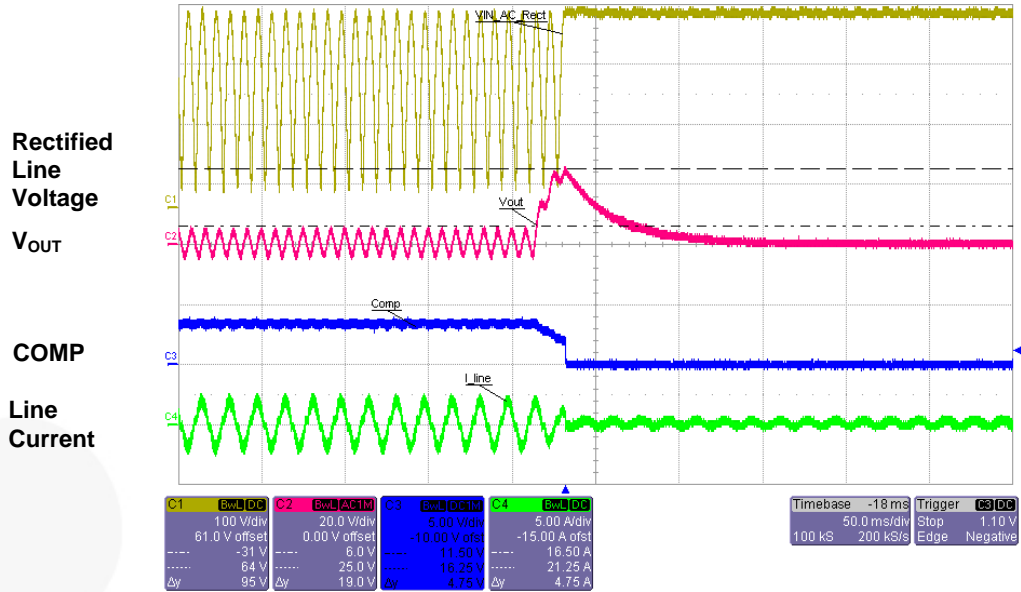
**Figure 31. Load Transient Response at 115V<sub>AC</sub> (Full Load → No Load)**



CH1: Rectified Line Voltage (100V/div), CH2: Output Voltage (20V/div, AC), CH3: COMP Voltage (2V/div), CH4: Line Current (5A/div), Time (50ms/div)

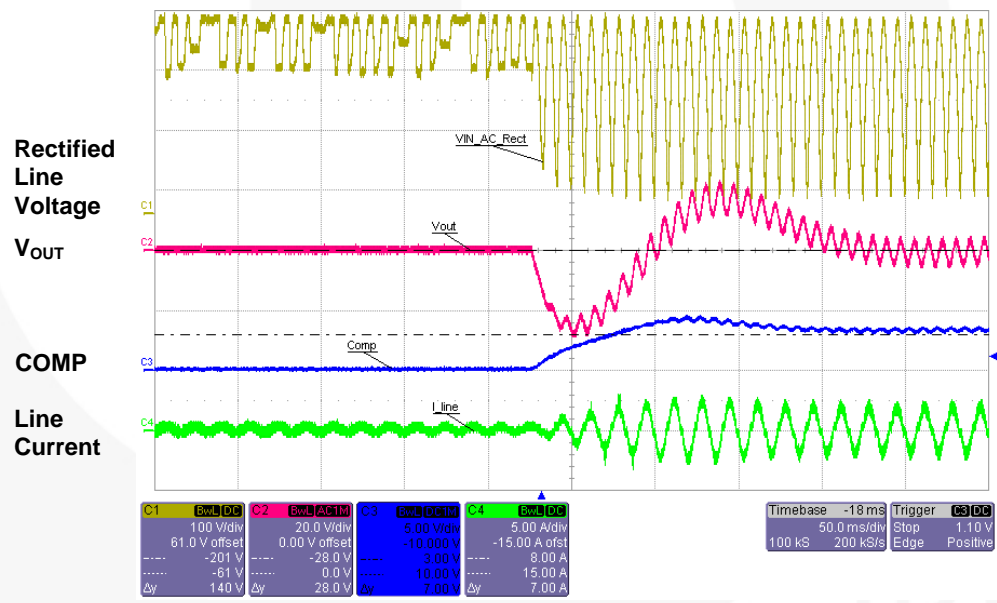
**Figure 32. Load Transient Response at 115V<sub>AC</sub> (No Load → Full Load)**





CH1: Rectified Line Voltage (100V/div), CH2: Output Voltage (20V/div, AC), CH3: COMP Voltage (5V/div), CH4: Line Current (5A/div), Time (50ms/div)

Figure 33. Load Transient Response at 230V<sub>AC</sub> (Full Load → No Load)

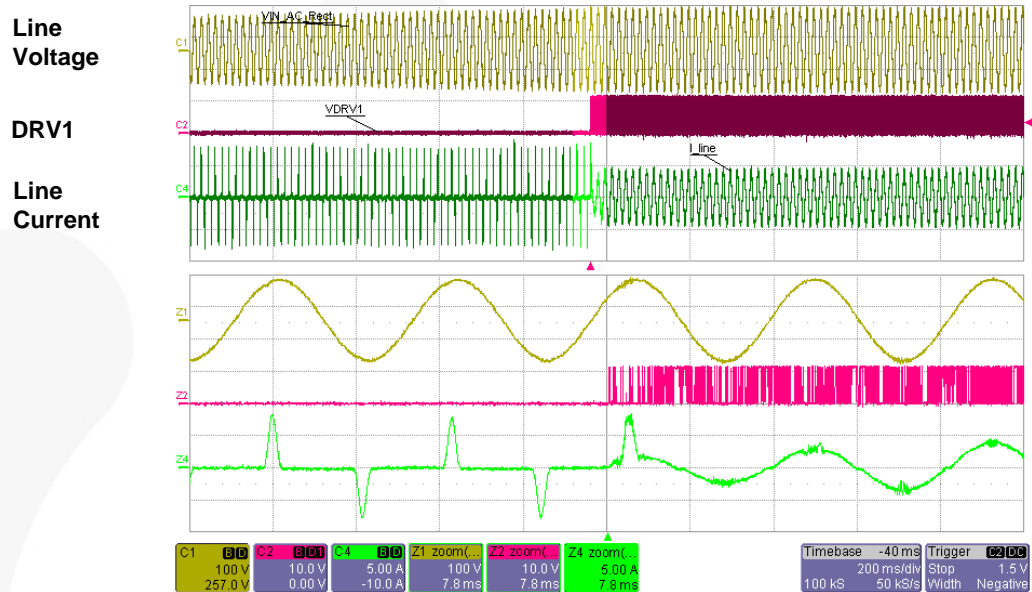


CH1: Rectified Line Voltage (100V/div), CH2: Output Voltage (20V/div, AC), CH3: COMP Voltage (5V/div), CH4: Line Current (5A/div), Time (50ms/div)

Figure 34. Load Transient Response at 230V<sub>AC</sub> (No Load → Full Load)

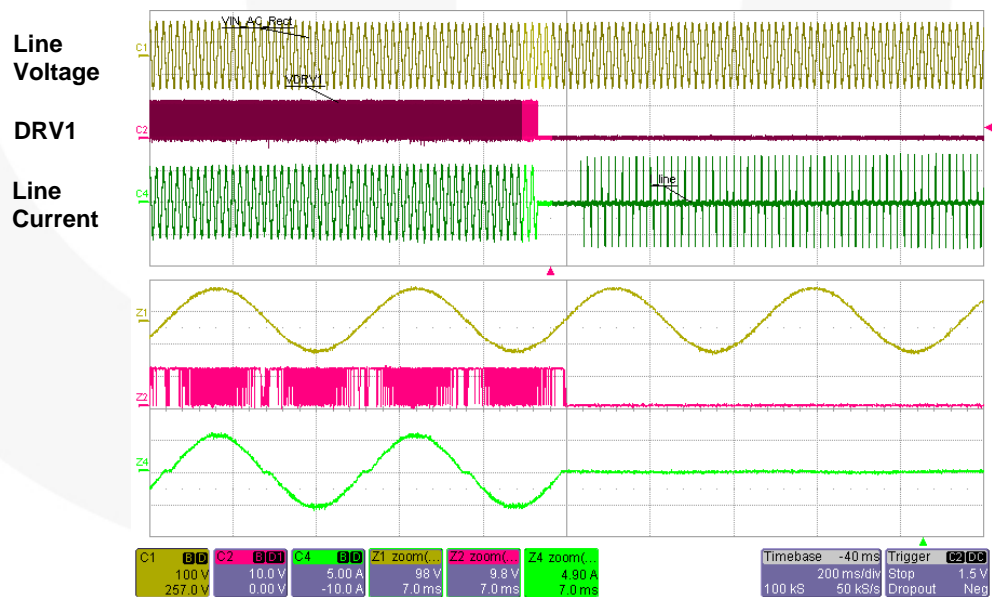
## 10.5. Brownout Protection

Figure 35 shows the startup operation while slowly increasing the line voltage. The power supply starts up when the line voltage reaches around 90V<sub>AC</sub>. Figure 36 shows the shutdown operation while slowly decreasing the line voltage. The power supply shuts down when the line voltage reaches around 80V<sub>AC</sub>.



CH1: Line Voltage (100V/div), CH2: Gate Drive 1 Voltage (10V/div),  
CH4: Line Current (5A/div), Time (200ms/div)

**Figure 35. Startup Slowly Increasing the Line Voltage**

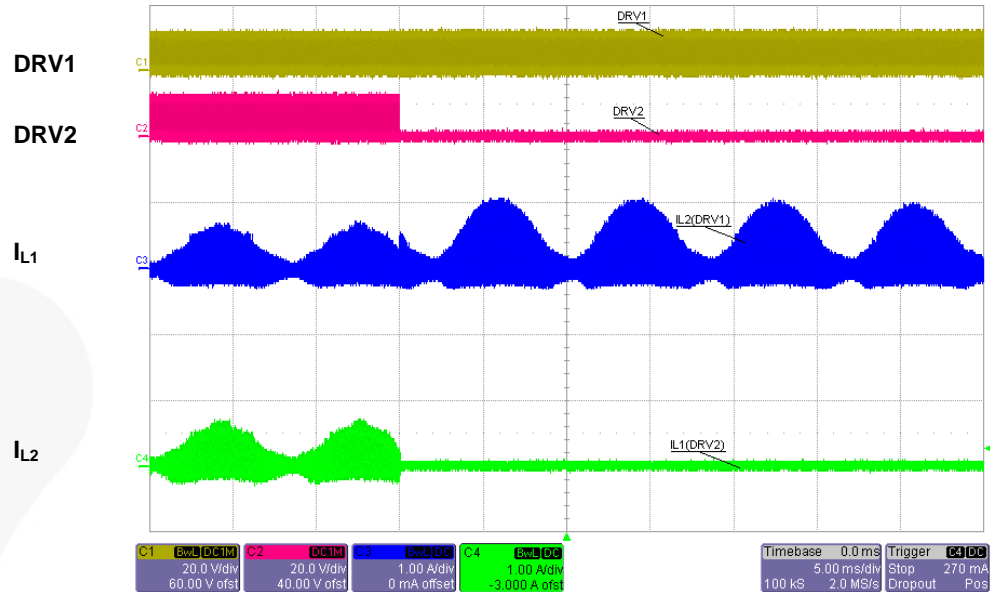


CH1: Line Voltage (100V/div), CH2: Gate Drive 1 Voltage (10V/div),  
CH4: Line Current (5A/div), Time (20ms/div)

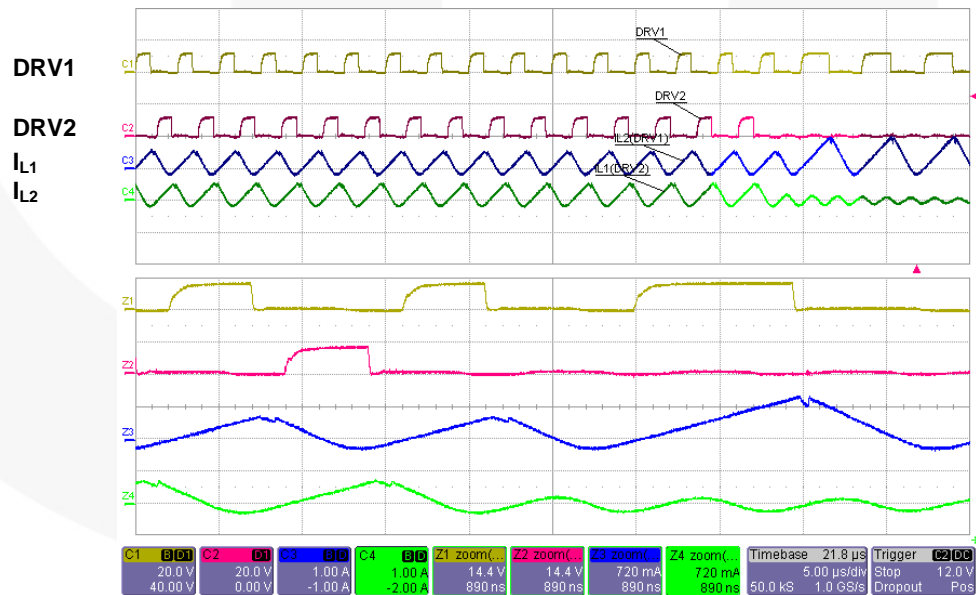
**Figure 36. Shutdown Slowly Decreasing the Line Voltage**

## 10.6. Phase Management

Figure 37 and Figure 38 show the phase-shedding waveforms. As observed, when the gate drive signal of Channel 2 is disabled, the duty cycle of Channel 1 gate drive signal is doubled to minimize the line current glitch and guarantee smooth transient.

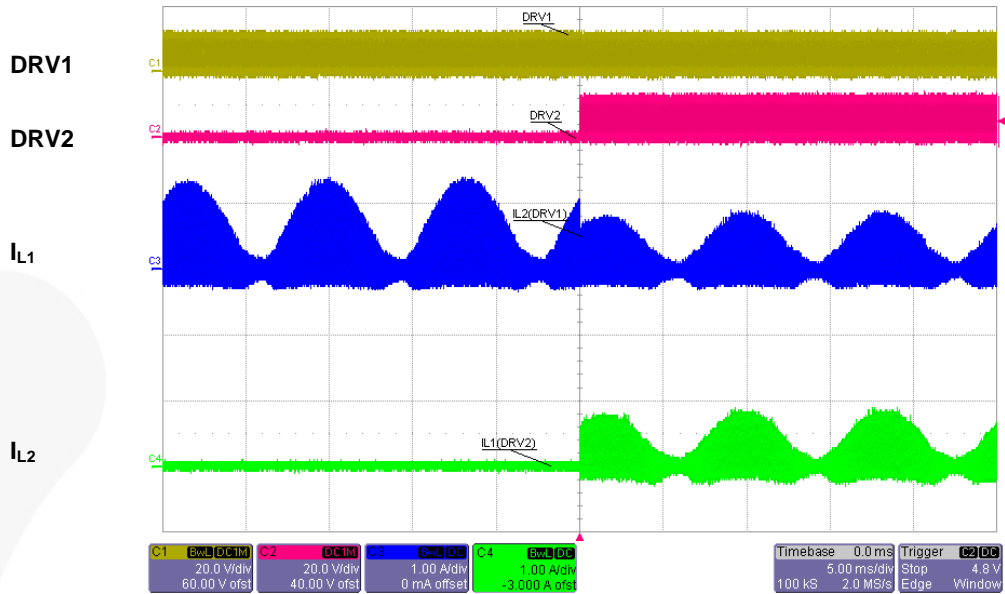


**Figure 37. Phase-Shedding Operation**



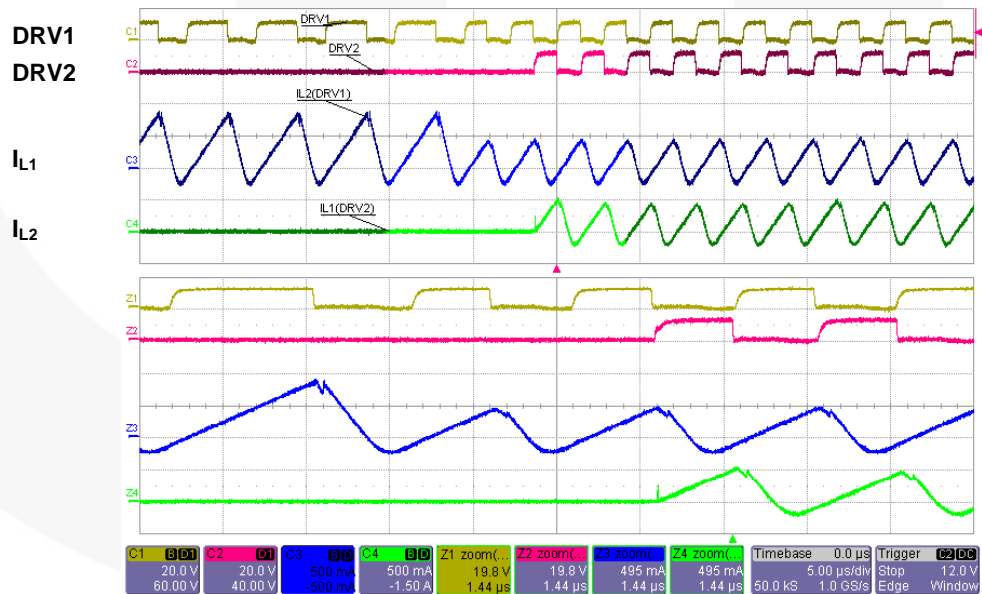
**Figure 38. Phase-Shedding Operation (Zoomed-in Timescale)**

Figure 39 and Figure 40 show the phase-adding waveforms. As observed, just before the Channel 2 gate drive signal is enabled, the duty cycle of Channel 1 gate drive signal is reduced by 50% to minimize the line current glitch and guarantee smooth transient. In Figure 40, the first pulse of gate drive 2 during the phase-adding operation is skipped to ensure 180° out-of-phase interleaving operation during transient.



CH1: Gate Drive 1 Voltage (20V/div), CH2: Gate Drive 2 Voltage (20V/div),  
CH3: Inductor L1 Current (1A/div), CH4: Inductor L2 Current (1A/div), Time (5ms/div)

**Figure 39. Phase-Adding Operation**



CH1: Gate Drive 1 Voltage (20V/div), CH2: Gate Drive 2 Voltage (20V/div),  
CH3: Inductor L1 Current (1A/div), CH4: Inductor L2 Current (1A/div), Time (5µs/div)

**Figure 40. Phase-Adding Operation (Zoomed-in Timescale)**

## 10.7. Efficiency

Figure 41 and Figure 42 show the measured efficiency of the 300W evaluation board with  $R_{MOT}=60.4k\Omega$  at input voltages of  $115V_{AC}$  and  $230V_{AC}$ . The phase management threshold on the test evaluation board is approximately 15% of the nominal output power. The threshold can be adjusted upwards to achieve a more desirable efficiency profile by increasing the MOT resistor. Figure 43 and Figure 44 show the light-load efficiency improvement that can be achieved when the threshold is adjusted to 30% by increasing the MOT resistor to  $120k\Omega$ .

Since phase shedding reduces the switching loss by effectively decreasing the switching frequency at light load, greater efficiency improvement is achieved at  $230V_{AC}$ , where switching losses dominate. Relatively less improvement is obtained at  $115V_{AC}$ , since the MOSFET is turned on with zero voltage and switching losses are negligible. The efficiency measurements include the losses in the EMI filter, cable loss and power consumption of the control IC.

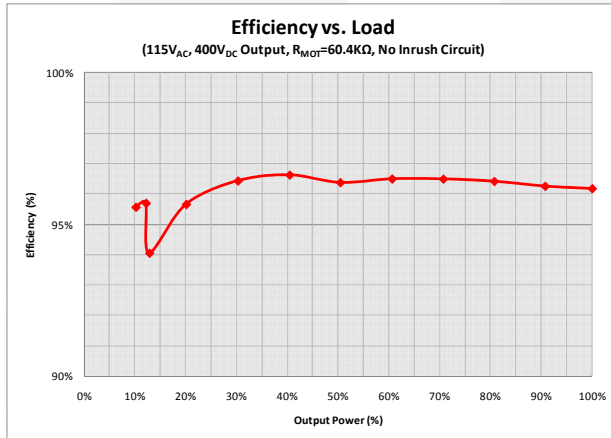


Figure 41. Efficiency vs. Load (115V<sub>AC</sub>)

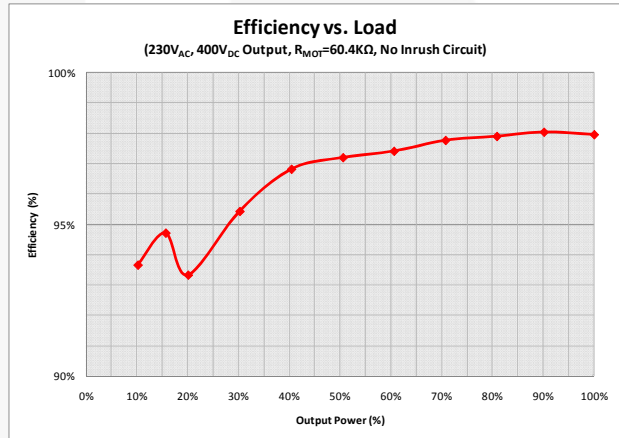


Figure 42. Efficiency vs. Load (230V<sub>AC</sub>)

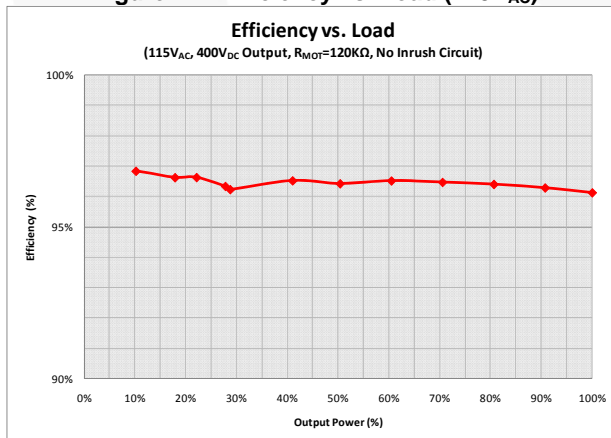


Figure 43. Efficiency vs. Load (115V<sub>AC</sub>)

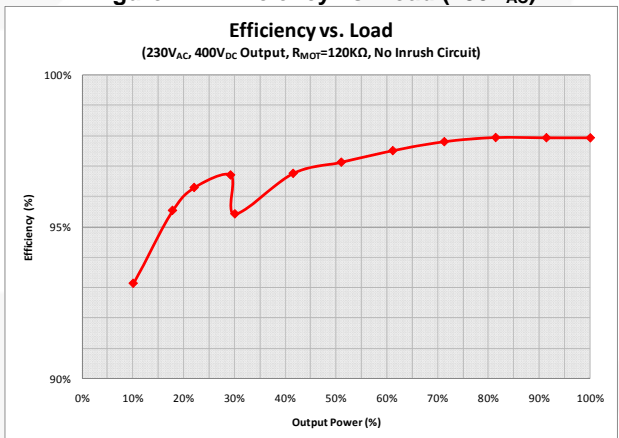
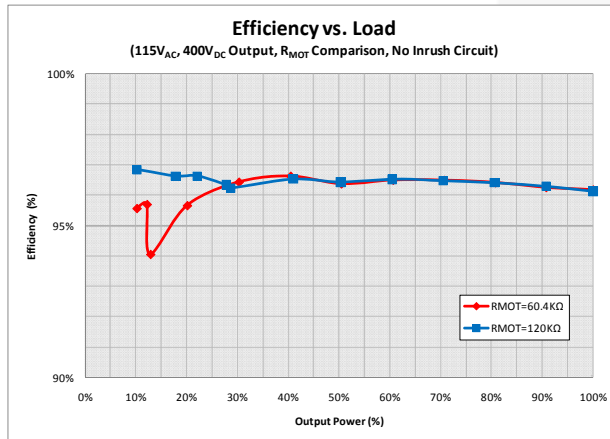
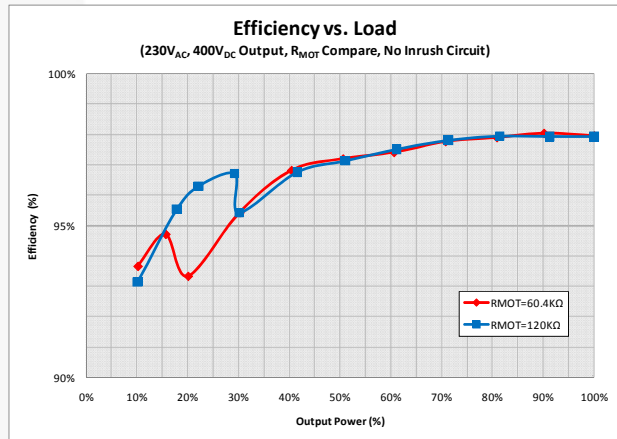


Figure 44. Efficiency vs. Load (230V<sub>AC</sub>)

Figure 45 and Figure 46 show a direct comparison of light-load efficiency benefit gained when increasing the MOT resistor. For  $R_{MOT}=120k\Omega$ , the phase threshold is adjusted upward from 18% to approximately 30% of nominal maximum output power. It is not recommended to adjust the phase threshold near the 50% nominal maximum output power, since each individual BCM PFC channel is optimally designed to process 50% (plus 20% margin) of the total output power required by the load.



**Figure 45. Efficiency vs. Load (115V<sub>AC</sub>)**



**Figure 46. Efficiency vs. Load (230V<sub>AC</sub>)**

The FEBFAN9611\_S01U300A evaluation board is configured with  $R_{MOT}=60.4k\Omega$ , which sets the maximum output power limit to about 360W. Because of the highly optimized, low-profile cross-section of this design; the EFD30 inductors are not rated to process more than 200W each (400W total output power). When the MOT resistor is increased to 120k $\Omega$ , the maximum allowable output power is also increased to greater than 400W. To fully protect the power stage, a simple voltage divider and PNP clamp should be applied to the FAN9611 COMP voltage (pin 7) as detailed in [AN-6086](#), Figure 15.



## 10.8. Harmonic Distortion and Power Factor

Figure 47 and Figure 48 compare the measured harmonic current with EN61000 Class D and Class C, respectively, at input voltages of 115V<sub>AC</sub> and 230V<sub>AC</sub>. Class D is applied to TV and PC power, while Class C is applied to lighting applications. As can be observed, both regulations are met with sufficient margin.

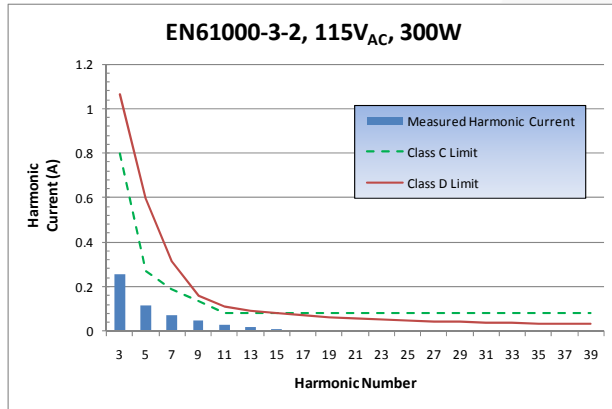


Figure 47. Harmonic Current, 115V<sub>AC</sub>

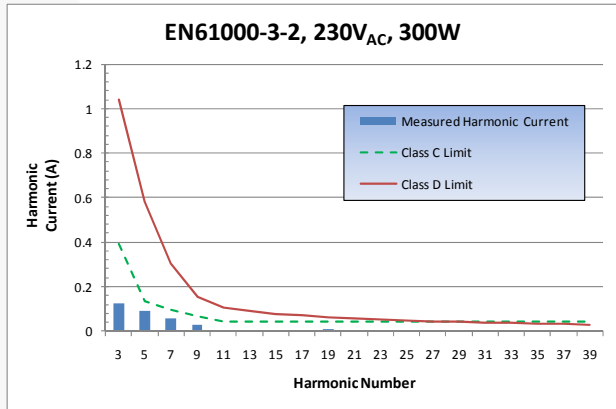


Figure 48. Harmonic Current, 230V<sub>AC</sub>

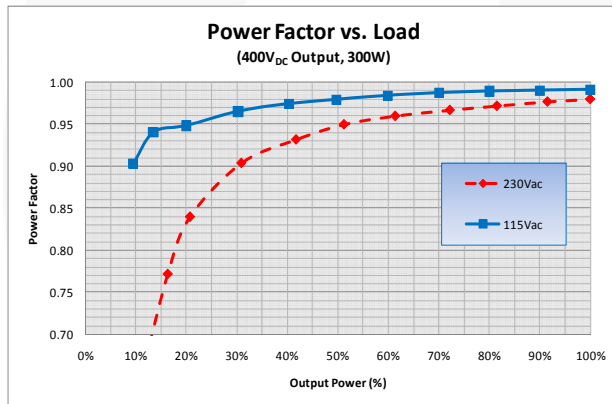


Figure 49. Measured Power Factor

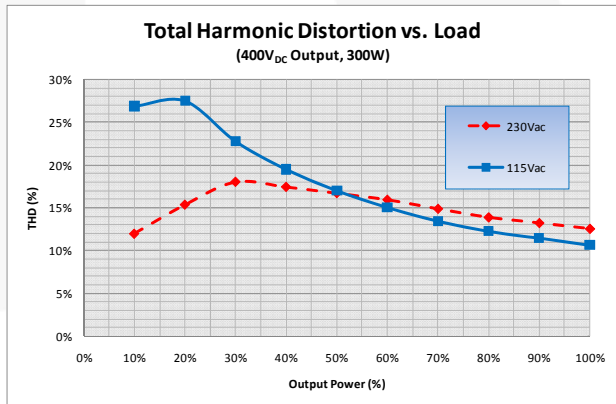
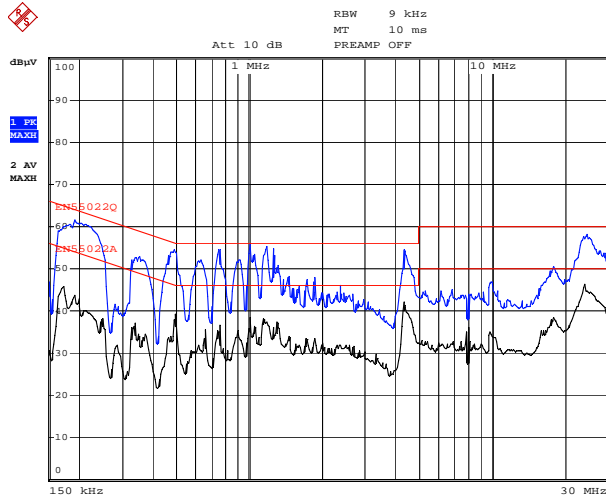


Figure 50. Measured Total Harmonic Distortion

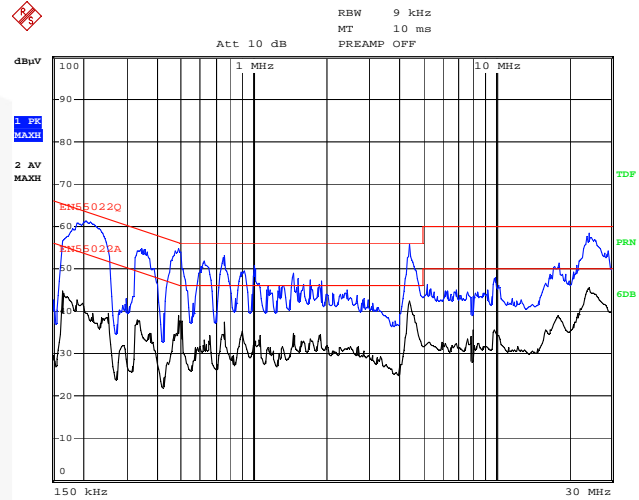
Figure 49 shows the measured power factor at input voltage of 115V<sub>AC</sub> and 230V<sub>AC</sub>. As observed, high power factor above 0.95 is obtained from 100% to 50% load. Figure 50 shows the total harmonic distortion at input voltages of 115V<sub>AC</sub> and 230V<sub>AC</sub>.

## 10.9. EMI

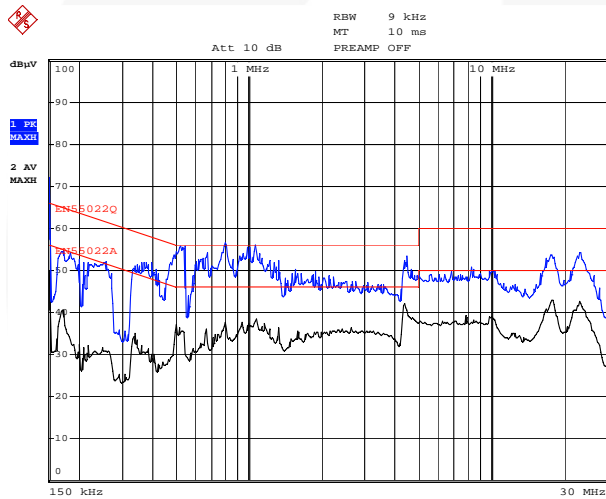
### EN55022 CISPR, Class B



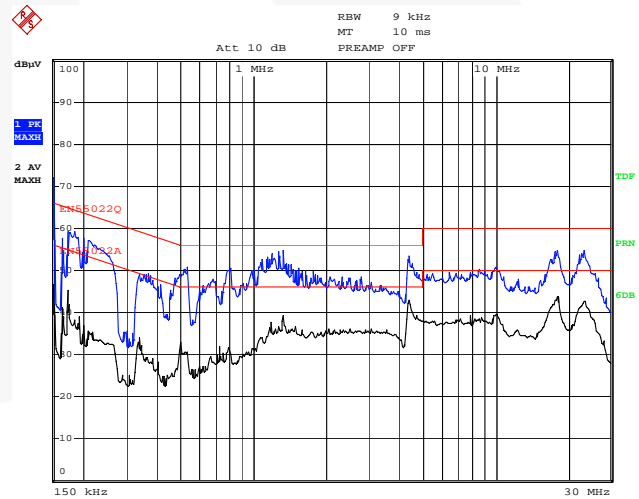
**Figure 51. 115V<sub>AC</sub>, Line**



**Figure 52. 115V<sub>AC</sub>, Neutral**



**Figure 53. 230V<sub>AC</sub>, Line**



**Figure 54. 230V<sub>AC</sub>, Neutral**

## 11. References

- [1] [FAN9611 / FAN9612 — Interleaved Dual BCM PFC Controllers](#)
- [2] [AN-6086 — Design Considerations for Interleaved Boundary-Conduction Mode PFC Using FAN9611 / FAN9612](#)

## 12. Ordering Information

Orderable Part Number	Description
FEBFAN9611_S01U300A	FAN9611 300W Evaluation Board

## 13. Revision History

Date	Revision	Description
February 2012	0.0.1	Initial release

### WARNING AND DISCLAIMER

Replace components on the Evaluation Board only with those parts shown on the parts list (or Bill of Materials) in the Users' Guide. Contact an authorized Fairchild representative with any questions.

This board is intended to be used by certified professionals, in a lab environment, following proper safety procedures. Use at your own risk. The Evaluation board (or kit) is for demonstration purposes only and neither the Board nor this User's Guide constitute a sales contract or create any kind of warranty, whether express or implied, as to the applications or products involved. Fairchild warrants that its products meet Fairchild's published specifications, but does not guarantee that its products work in any specific application. Fairchild reserves the right to make changes without notice to any products described herein to improve reliability, function, or design. Either the applicable sales contract signed by Fairchild and Buyer or, if no contract exists, Fairchild's standard Terms and Conditions on the back of Fairchild invoices, govern the terms of sale of the products described herein.

#### DISCLAIMER

FAIRCHILD SEMICONDUCTOR RESERVES THE RIGHT TO MAKE CHANGES WITHOUT FURTHER NOTICE TO ANY PRODUCTS HEREIN TO IMPROVE RELIABILITY, FUNCTION, OR DESIGN. FAIRCHILD DOES NOT ASSUME ANY LIABILITY ARISING OUT OF THE APPLICATION OR USE OF ANY PRODUCT OR CIRCUIT DESCRIBED HEREIN; NEITHER DOES IT CONVEY ANY LICENSE UNDER ITS PATENT RIGHTS, NOR THE RIGHTS OF OTHERS.

#### LIFE SUPPORT POLICY

FAIRCHILD'S PRODUCTS ARE NOT AUTHORIZED FOR USE AS CRITICAL COMPONENTS IN LIFE SUPPORT DEVICES OR SYSTEMS WITHOUT THE EXPRESS WRITTEN APPROVAL OF THE PRESIDENT OF FAIRCHILD SEMICONDUCTOR CORPORATION.

As used herein:

1. Life support devices or systems are devices or systems which, (a) are intended for surgical implant into the body, or (b) support or sustain life, or (c) whose failure to perform when properly used in accordance with instructions for use provided in the labeling, can be reasonably expected to result in significant injury to the user.
2. A critical component is any component of a life support device or system whose failure to perform can be reasonably expected to cause the failure of the life support device or system, or to affect its safety or effectiveness

### ANTI-COUNTERFEITING POLICY

Fairchild Semiconductor Corporation's Anti-Counterfeiting Policy. Fairchild's Anti-Counterfeiting Policy is also stated on our external website, [www.fairchildsemi.com](http://www.fairchildsemi.com), under Sales Support.

Counterfeiting of semiconductor parts is a growing problem in the industry. All manufacturers of semiconductor products are experiencing counterfeiting of their parts. Customers who inadvertently purchase counterfeit parts experience many problems such as loss of brand reputation, substandard performance, failed applications, and increased cost of production and manufacturing delays. Fairchild is taking strong measures to protect ourselves and our customers from the proliferation of counterfeit parts. Fairchild strongly encourages customers to purchase Fairchild parts either directly from Fairchild or from Authorized Fairchild Distributors who are listed by country on our web page cited above. Products customers buy either from Fairchild directly or from Authorized Fairchild Distributors are genuine parts, have full traceability, meet Fairchild's quality standards for handling and storage and provide access to Fairchild's full range of up-to-date technical and product information. Fairchild and our Authorized Distributors will stand behind all warranties and will appropriately address any warranty issues that may arise. Fairchild will not provide any warranty coverage or other assistance for parts bought from Unauthorized Sources. Fairchild is committed to combat this global problem and encourage our customers to do their part in stopping this practice by buying direct or from authorized distributors.

### EXPORT COMPLIANCE STATEMENT

These commodities, technology, or software were exported from the United States in accordance with the Export Administration Regulations for the ultimate destination listed on the commercial invoice. Diversion contrary to U.S. law is prohibited.

U.S. origin products and products made with U.S. origin technology are subject to U.S. Re-export laws. In the event of re-export, the user will be responsible to ensure the appropriate U.S. export regulations are followed.

ON Semiconductor and  are trademarks of Semiconductor Components Industries, LLC dba ON Semiconductor or its subsidiaries in the United States and/or other countries. ON Semiconductor owns the rights to a number of patents, trademarks, copyrights, trade secrets, and other intellectual property. A listing of ON Semiconductor's product/patent coverage may be accessed at [www.onsemi.com/site/pdf/Patent-Marking.pdf](http://www.onsemi.com/site/pdf/Patent-Marking.pdf). ON Semiconductor reserves the right to make changes without further notice to any products herein. ON Semiconductor makes no warranty, representation or guarantee regarding the suitability of its products for any particular purpose, nor does ON Semiconductor assume any liability arising out of the application or use of any product or circuit, and specifically disclaims any and all liability, including without limitation special, consequential or incidental damages. Buyer is responsible for its products and applications using ON Semiconductor products, including compliance with all laws, regulations and safety requirements or standards, regardless of any support or applications information provided by ON Semiconductor. "Typical" parameters which may be provided in ON Semiconductor data sheets and/or specifications can and do vary in different applications and actual performance may vary over time. All operating parameters, including "Typicals" must be validated for each customer application by customer's technical experts. ON Semiconductor does not convey any license under its patent rights nor the rights of others. ON Semiconductor products are not designed, intended, or authorized for use as a critical component in life support systems or any FDA Class 3 medical devices or medical devices with a same or similar classification in a foreign jurisdiction or any devices intended for implantation in the human body. Should Buyer purchase or use ON Semiconductor products for any such unintended or unauthorized application, Buyer shall indemnify and hold ON Semiconductor and its officers, employees, subsidiaries, affiliates, and distributors harmless against all claims, costs, damages, and expenses, and reasonable attorney fees arising out of, directly or indirectly, any claim of personal injury or death associated with such unintended or unauthorized use, even if such claim alleges that ON Semiconductor was negligent regarding the design or manufacture of the part. ON Semiconductor is an Equal Opportunity/Affirmative Action Employer. This literature is subject to all applicable copyright laws and is not for resale in any manner.

## PUBLICATION ORDERING INFORMATION

### LITERATURE FULFILLMENT:

Literature Distribution Center for ON Semiconductor  
19521 E. 32nd Pkwy, Aurora, Colorado 80011 USA  
**Phone:** 303-675-2175 or 800-344-3860 Toll Free USA/Canada  
**Fax:** 303-675-2176 or 800-344-3867 Toll Free USA/Canada  
**Email:** [orderlit@onsemi.com](mailto:orderlit@onsemi.com)

**N. American Technical Support:** 800-282-9855 Toll Free  
USA/Canada  
**Europe, Middle East and Africa Technical Support:**  
Phone: 421 33 790 2910  
**Japan Customer Focus Center**  
Phone: 81-3-5817-1050

**ON Semiconductor Website:** [www.onsemi.com](http://www.onsemi.com)  
**Order Literature:** <http://www.onsemi.com/orderlit>  
For additional information, please contact your local  
Sales Representative