

AND9482/D

Diode Detector Circuit using the NSVR351SDSA3

Overview

This application note explains about ON Semiconductor's NSVR351SDSA3 which is used as a diode detector circuit.

A Schottky diode is a diode using the schottky barrier generating due to the junction of the metal and the semiconductor. Because of its low forward voltage and fast switching operation, it is suitable for high-frequency use.

In wireless applications like radio, in order to adjust the received power level and to transmit the target power to the amplifier, it is necessary to detect the received power and to feed back the detection voltage through an AGC circuit. A Schottky diode is used in detection circuit in this case.

The principle of diode detection is rectifying the signal (AC component) through a diode and generating voltage as DC component. The detection makes use of the non-linear characteristic of the Schottky diode, so a bias circuit is not necessary.



ON Semiconductor®

www.onsemi.com

APPLICATION NOTE

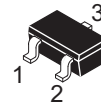

SC-59 / CP3

AND9482/D

■ Circuit Design

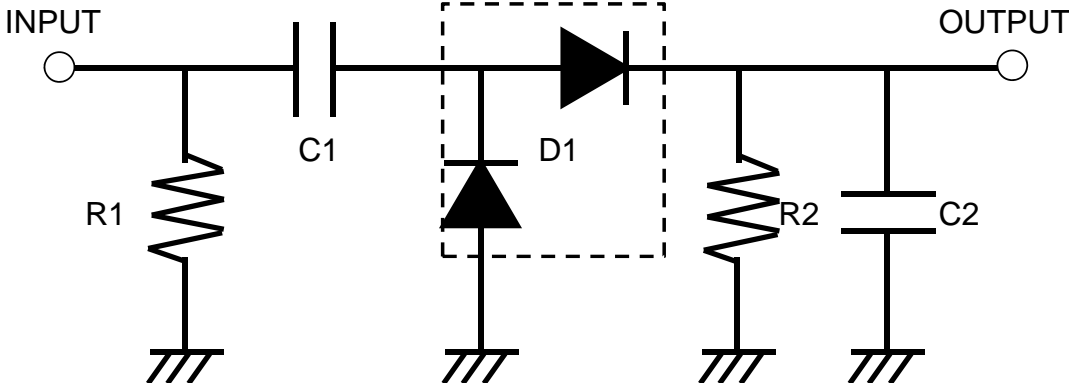

■ Evaluation Board

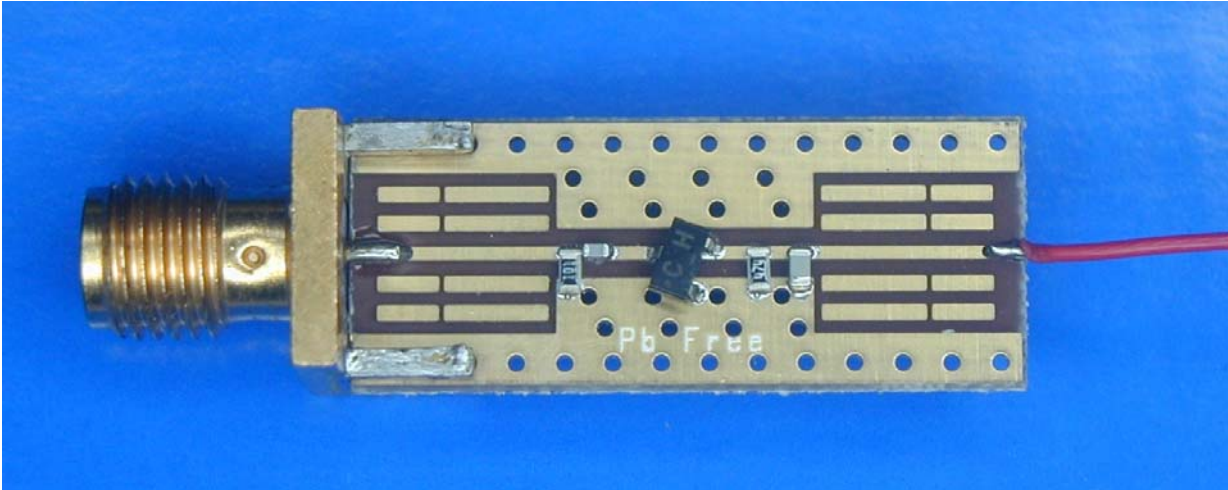

AND9482/D

■ Bill of Materials

Item	Symbol	Value	Manufacture	Size
SBD	D1	NSVR351SDSA3	ON Semiconductor	SC-59
Capacitor	C1	1000 pF	Various	1005
	C2	1000 pF	Various	1608
Resistor	R1	100 Ω	Various	1608
	R2	470k Ω	Various	1608
Material		FR-4		25 x 10 mm

AND9482/D

■ Spice Model

Model : Diode

Parameter	Value	Unit	Parameter	Value	Unit
IS	500n	A	TT	5n	S
N	1		XTI	2.0	
BV	5.0	V	EG	0.69	eV
IBV	200μ	A	Cp1	90f	F
RS	1.7	Ω	Cp2	90f	F
FC	0.5		LI1	0.8n	H
CJO	700f	F	LI2	0.8n	H
VJ	240m	V	LI3	0.5n	H
M	157m		Lw1	0.8n	H
			Lw2	0.8n	H

■ Equivalent Circuit Model

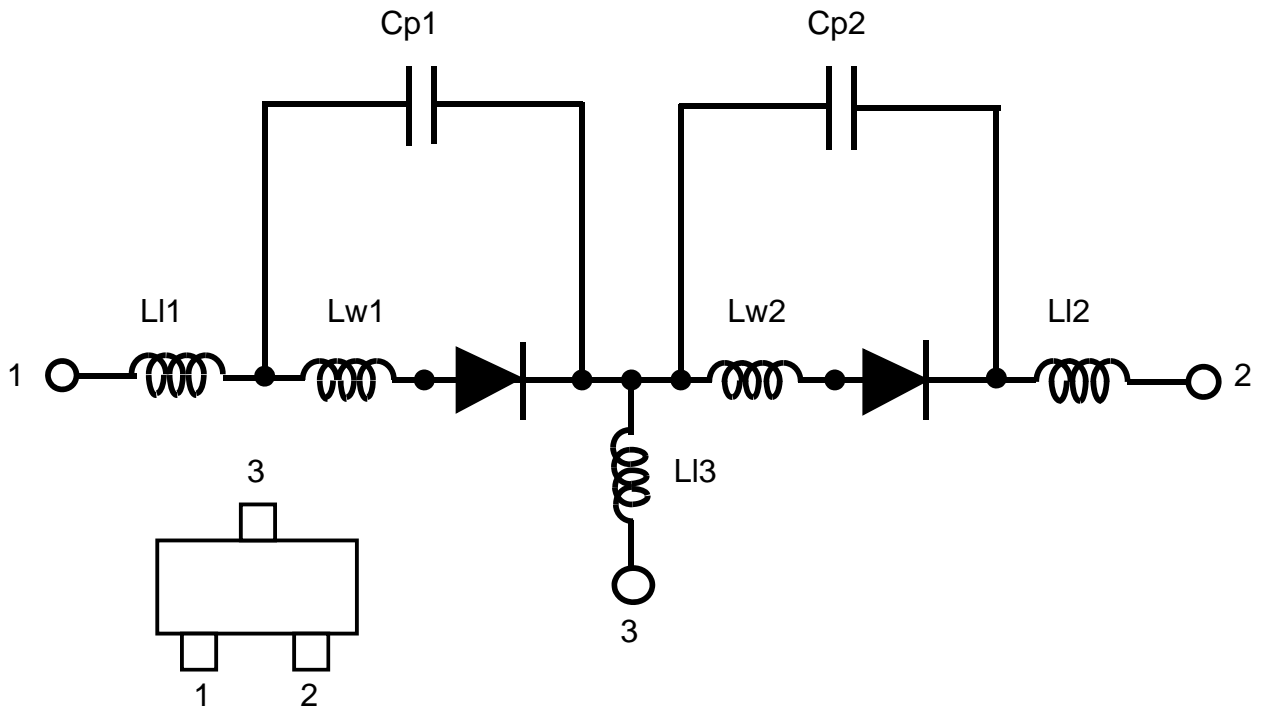

■ Measurement Results

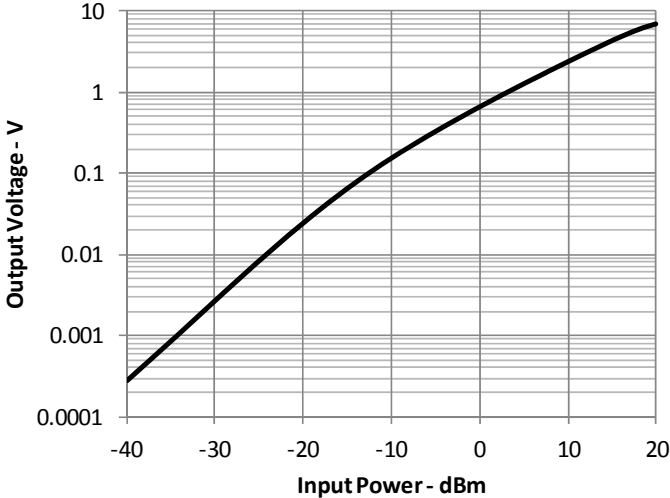

Figure 1 Output Voltage vs. Input Power

ON Semiconductor and the ON logo are registered trademarks of Semiconductor Components Industries, LLC (SCILLC) or its subsidiaries in the United States and/or other countries. SCILLC owns the rights to a number of patents, trademarks, copyrights, trade secrets, and other intellectual property. A listing of SCILLC's product/patent coverage may be accessed at www.onsemi.com/site/pdf/Patent-Marking.pdf. SCILLC reserves the right to make changes without further notice to any products herein. SCILLC makes no warranty, representation or guarantee regarding the suitability of its products for any particular purpose, nor does SCILLC assume any liability arising out of the application or use of any product or circuit, and specifically disclaims any and all liability, including without limitation special, consequential or incidental damages. "Typical" parameters which may be provided in SCILLC data sheets and/or specifications can and do vary in different applications and actual performance may vary over time. All operating parameters, including "Typicals" must be validated for each customer application by customer's technical experts. SCILLC does not convey any license under its patent rights nor the rights of others. SCILLC products are not designed, intended, or authorized for use as components in systems intended for surgical implant into the body, or other applications intended to support or sustain life, or for any other application in which the failure of the SCILLC product could create a situation where personal injury or death may occur. Should Buyer purchase or use SCILLC products for any such unintended or unauthorized application, Buyer shall indemnify and hold SCILLC and its officers, employees, subsidiaries, affiliates, and distributors harmless against all claims, costs, damages, and expenses, and reasonable attorney fees arising out of, directly or indirectly, any claim of personal injury or death associated with such unintended or unauthorized use, even if such claim alleges that SCILLC was negligent regarding the design or manufacture of the part. SCILLC is an Equal Opportunity/Affirmative Action Employer. This literature is subject to all applicable copyright laws and is not for resale in any manner.