



ON Semiconductor

Step Dimming Guidelines for NCL30081/83 LED Drivers

Device	Application	Input Voltage	Output Power	Topology	I/O Isolation
NCL30081/83	LED Lighting	100 - 265 V ac	na	CrM	na

Overview

The ability to dim household lighting is a desirable feature that has been common in residential lighting for over 50 years. A dimmer accomplishes this is but requires installation replacing a switch in the appropriate electrical box. The installation is often beyond the typical home repair requiring a qualified electrician. The NCL30081/83 incorporates a step dimming feature that changes the LED bulb output whenever the AC is interrupted briefly using a existing wall switch. Toggling the wall switch on/off for a 1-5 s steps down the bulb output in 6 discrete steps. After the last step, the bulb goes back to 100% brightness. This approach allows the customer to add dimming capability to a fixture without the need to make changes to the electrical wiring.

Theory of Operation

The NCL30081/83 detects the presence of the AC line through the Vin pin. If Vin is lost for more than 50ms, the Brown Out detector turns off the output and decrements the step dimming register

reducing the output current.

Dimming Step	I _{out}	Perceived Light
ON	100%	100%
1	70%	84%
2	40%	63%
3	25%	50%
4	10%	32%
5	5%	17%

Dimming Table 1

The internal circuit architecture is shown below for the BO detection.

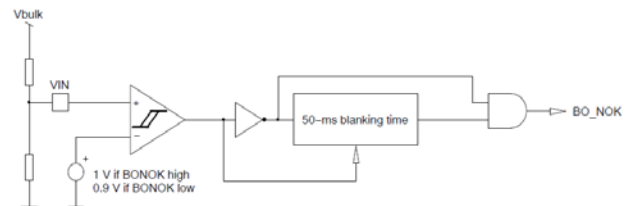

The Vcc voltage will drop when the BO detector shuts off the output. When Vcc drops to the Vcc_off threshold (~9 V), the current draw on the Vcc pin drops to about 50 μA. The state of the dimming register is retained until Vcc reaches Vcc_reset which is about 5 V. When AC power returns, the BO detector senses good power and turns on the output again at the new current setting. The size of the Vcc capacitor determines the hold up time between Vcc_off and Vcc_reset. This is the window of time to toggle the dimming register. If Vcc drops below Vcc_reset, the

dimming register is cleared. When power is restored, the output will be at 100%.

Design Guidelines

Use of a split Vcc supply is necessary to ensure adequate hold up time to provide 1s - 5s of step dimming time while not inhibiting fast start up.

The split supply is shown below.

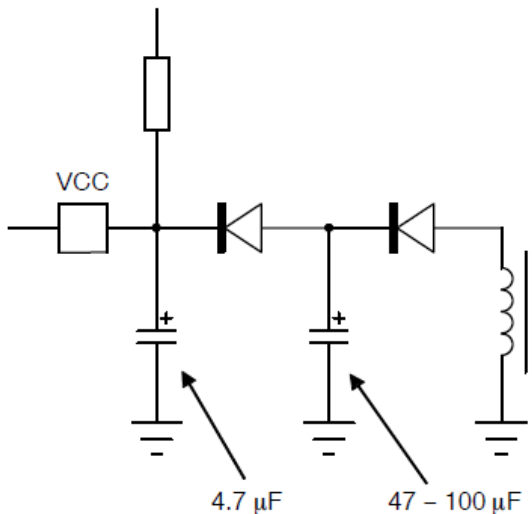

The 47μF capacitor does not load the Vcc terminal during start up thus assuring a fast start. After the converter starts switching, the 47μF capacitor provides a large energy storage element to keep the Vcc in the active region for a minimum of 50ms (the brown out detect period).

Timing Guidelines

Poor dimming performance can be traced back to timing race issue.

1. Vcc Decay
2. Output Voltage rise time

Vcc Decay

When the input power is interrupted, the output decays as the input energy storage is depleted.

The decay of the Vcc voltage is dependent on Icc and the available stored energy in the Vcc filter circuit. If the Vcc voltage falls below Vcc_off before the BO timer has timed to 50ms, the dimming register will not decrement the current. It will hold the previous state. The result will be a driver that fails to decrement the current when the input power is toggled. The NCL30081/83 accepts a wide range of Vcc up to 26V while operating down to about 10V. Therefore it is advisable to operate Vcc as close to 26V as practical without causing an OVP condition. Setting Vcc can be a problem for designs that have wide output voltage requirements. One must also consider that the LED voltage will decrease some with reduced current. The driver may be able to drive a wide output voltage range but the step dimming range may be narrower because the Vcc decays before the BO timer decrements the dimming current state.

Output Voltage Rise time

The output voltage rise time is dependent on the driver output current and the output capacitance. The output capacitor is sized for ripple current at maximum load. The NCL30081/83 uses an open loop control for output current. Consequently, there is no slew rate improvement due to the gain of the feedback loop. The energy in the output capacitor must be satisfied before the current in the LEDs. Since the output current is fixed as an open loop event, the output voltage rise varies directly as the output current setting. Vcc voltage rise follows the output voltage rise because they

are coupled through the aux winding of the transformer. If the output current drive is at the lowest setting and the output voltage is low, the Vcc winding may not deliver enough voltage to bootstrap the Vcc supply before the Vcc capacitor gets to Vcc_off. In this case, the circuit gets stuck in an endless loop until the controller is reset to 100% output. While it may seem as though this is a fundamental limitation, there are some special characteristics of LEDs that make this scenario work.

1. Very small Output Capacitance
2. Very large Output Capacitance

In the first scenario, the output capacitance is chosen to be sufficiently small that the output voltage rises in time to bootstrap the Vcc/aux winding. The LED ripple current will be high at maximum current as a consequence. The second scenario is counter-intuitive because a very large output capacitor would only serve to further slow the output voltage rise. This would indeed be the case for a resistor load; however, LEDs act more like zener diodes and leave a large residual voltage on the output capacitor during brief power interruptions. It is the residual voltage on the output capacitor that allow the converter to recover at low output currents. Testing with a resistor load is **not** recommended with a step dimming driver.

Design Recommendations for Step Dimming

1. Operate Vcc as high as practical without causing an OVP at the maximum current and maximum output voltage.
2. Use the split Vcc supply to provide energy storage for Vcc
3. Size the output capacitor to be either small enough or large enough.
4. Testing with a resistive load will not work properly.

© 2014 ON Semiconductor.

Disclaimer: ON Semiconductor is providing this design note "AS IS" and does not assume any liability arising from its use; nor does ON Semiconductor convey any license to its or any third party's intellectual property rights. This document is provided only to assist customers in evaluation of the referenced circuit implementation and the recipient assumes all liability and risk associated with its use, including, but not limited to, compliance with all regulatory standards. ON Semiconductor may change any of its products at any time, without notice.

Design note created by Frazier Pruett e-mail: henry.pruett@onsemi.com.