



ON Semiconductor

DN06042/D

Design Note – DN06042/D

Self Protecting Cigarette Lighter Adapter (CLA)

Device	Application	Input Voltage	Output Power	Topology	I/O Isolation
NCP3063	Consumer/Industrial	8-24 V	4W	Buck	None

Characteristic	Min	Typ	Max	Unit
Output Voltage	4.98	5.01	5.03	V
Output Current	0	0.8	1	A
Oscillator Frequency		53		kHz
Output Voltage Ripple	12	32	80	mVpk-pk
Calculated Inductor peak Current (390 uH)	.83	.86	.89	A
Calculated Duty Cycle	24	50	78	%
Load Regulation I _{out} = 0.04-1A)	2	13	27	mV/A
Line regulation to 5V I _{out} = 1A) I _{out} = 0.25A)	-1.5 0.7	.2 1.8	1.4 2.66	%
CLA Converter Dimensions in inches (mm)	.686(17.4) x 2.754 (70)			

Circuit Description

The NCP3063 is a hysteretic regulator with pulse by pulse current limiting and frequency adjustment. The NCP3063 CLA (Cigarette Lighter Adapter) design is configured in a buck topology and the frequency has been set to 53 kHz to reduce switching losses. The DFN package was selected as the exposed pad on the bottom spreads heat to the ground plane and grounding clip. The CLA has several built in safety features the first of which is a fuse F1 shown in layout in Figure 1 and schematically in Figure 3. The fuse serves as a second layer of short circuit protection incase the main switch is shorted. The fuse also serves as reverse polarity protection in the event that positive and negative voltages are reversed on the input. If the opposite polarity is applied at the input the diode D2 starts to conduct and the fuse F1 is blown protecting the end users device and the rest of the CLA. The designer can choose to implement a user replaceable fuse or a one time protection device depending on the user case. The first layer of short circuit protection is the pulse by pulse current limiting provided by the NCP3063 which can be set by the sense resistor R5. The user interface indicator R9 and D3 give real time visual feedback to the customer as to the functionality of the adapter. If a short circuit was to occur at the output or the fuse was to blown the LED D3 will cease to illuminate.

Existing Product

MC34063	SOIC-8
FET	DPAK

New Product

NCP3063	DFN (4x4mm)
---------	-------------

New Thermally Enhanced Package Eliminates Need for External FET

Board Details

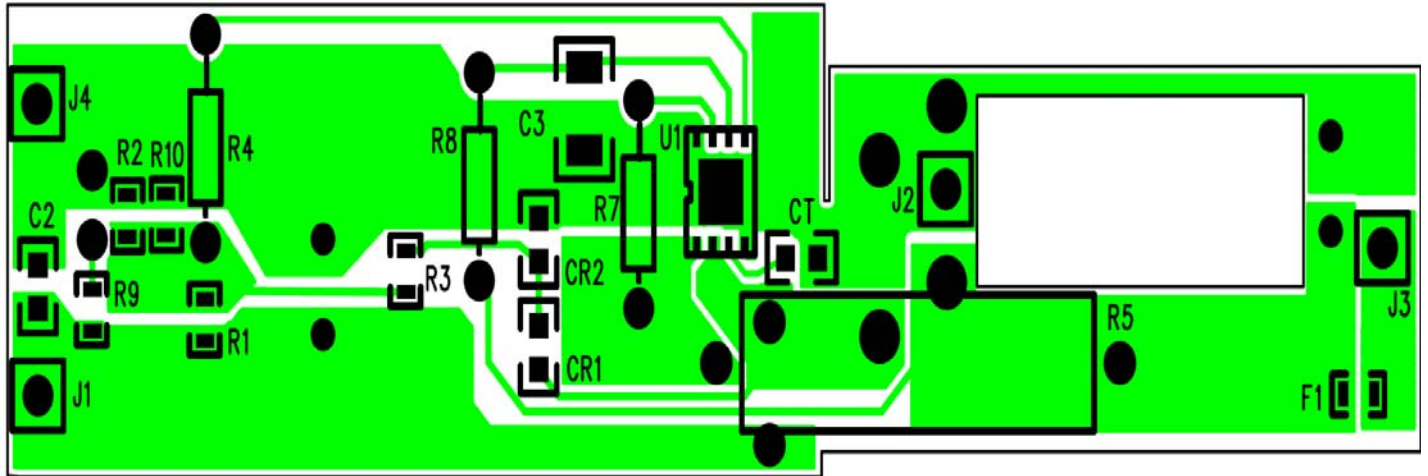

Figure 1 – NCP3063 CLA Top Layout and Silkscreen

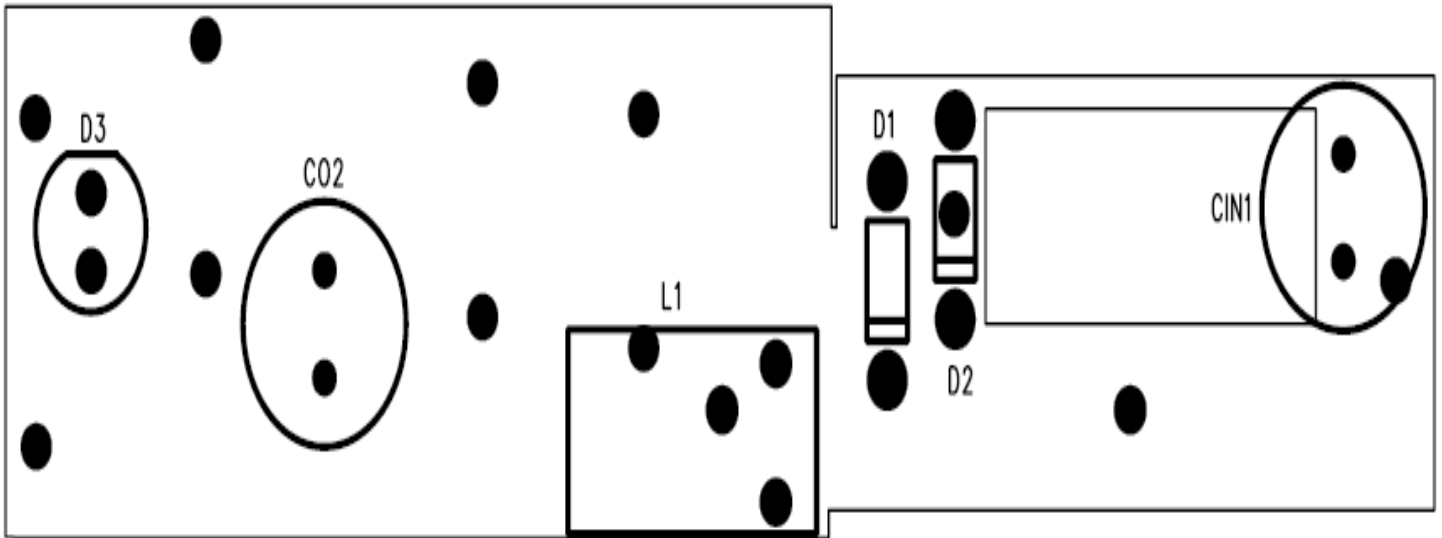

Figure 2 – NCP3063 Bottom Layout and Silkscreen

DN06042/D Schematic

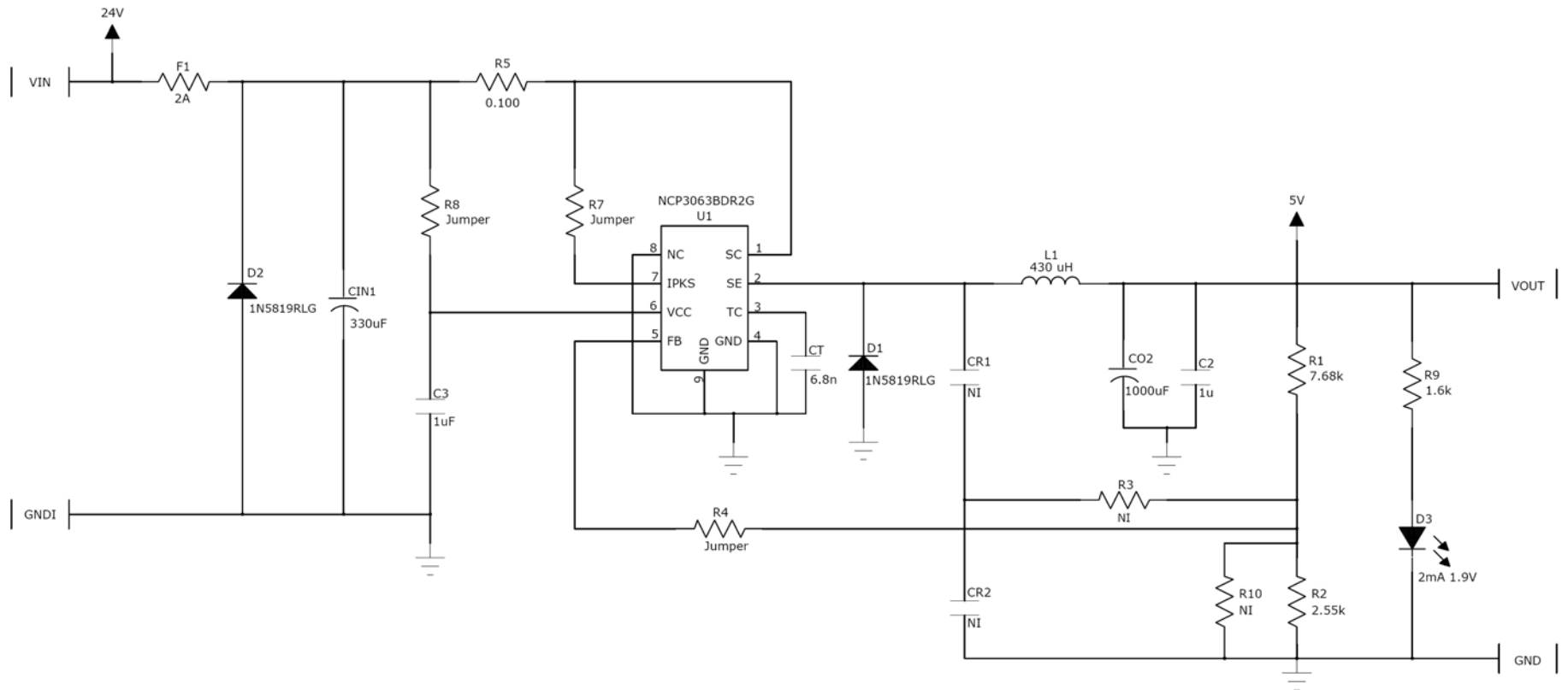

Figure 3 – NCP3063 Schematic

DN06042/D

Table 1 – NCP3063 CLA Bill of Materials

Designator	Quantity	Description	Value	Tolerance	Footprint	Manufacturer Part Number	Manufacturer
D1-2	2	40 V Schottky	0.60 Vf	NA	59-10	1N5819RLG	ON Semiconductor
C2	1	Ceramic Capacitor 6.3V	1 μ F	20%	603	06036D106MAT2A	AVX Corporation
CT	1	Ceramic Capacitor 6.3V	6.8n	10%	603	VJ0603Y682KXACW1BC	Vishay
CR1-2	2	Ceramic Capacitor 35V	NI	NI	603	NI	NI
C3	1	Ceramic Capacitor 35V	1 μ F	10%	1206	1206DD105KAT2A	AVX Corporation
CO2	1	AE Capacitors 16V	1000 μ F	20%	Through Hole	ESMG100ELL102ME11D	United Chemi-Con
CIN1	1	AE Capacitors 10V	330 μ F	20%	Through Hole	ESMG350ELL331MJC5S	United Chemi-Con
D3	1	Green LED	2mA 1.9V	NA	Through Hole	LG 3369-EJ-1-0-2-BULK	Osram
U1	1	1.5 A Switching Regulator	40 V 1.5A	NA	SOIC-8	NCP3063BDR2G	ON Semiconductor
R4 R7-8	3	Jumper	Jumper	NA	.4in th	923345-04-C	3M
R5	1	TH Resistor	0.1	1%	Through Hole	13FR100E	Ohmite
R9	1	SMT Resistor	1.62k	\pm 5.0%	0603	CRCW06031K62JNEA	Vishay / Dale
R2	1	SMT Resistor	2.55k	\pm 1.0%	0603	CRCW06032K55FKEA	Vishay / Dale
F1	1	Fast Acting Fuse	2A	a ² s – 0.1105	0603	0467002.NR	Littelfuse Inc
R1	1	SMT Resistor	7.68k	\pm 1.0%	0603	CRCW06037K68FKEA	Vishay / Dale
R3 R10	2	SMT Resistor	NI	NA	0603	NA	NA
L1	1	Inductor 0.4 Ohm	430 μ H	10%	Through Hole	IN08014	ICE
L1	1	Inductor 0.62 Ohm	390 μ H	%	Through Hole	RFB1010-391L	Coilcraft

Block Diagram – NCP3063

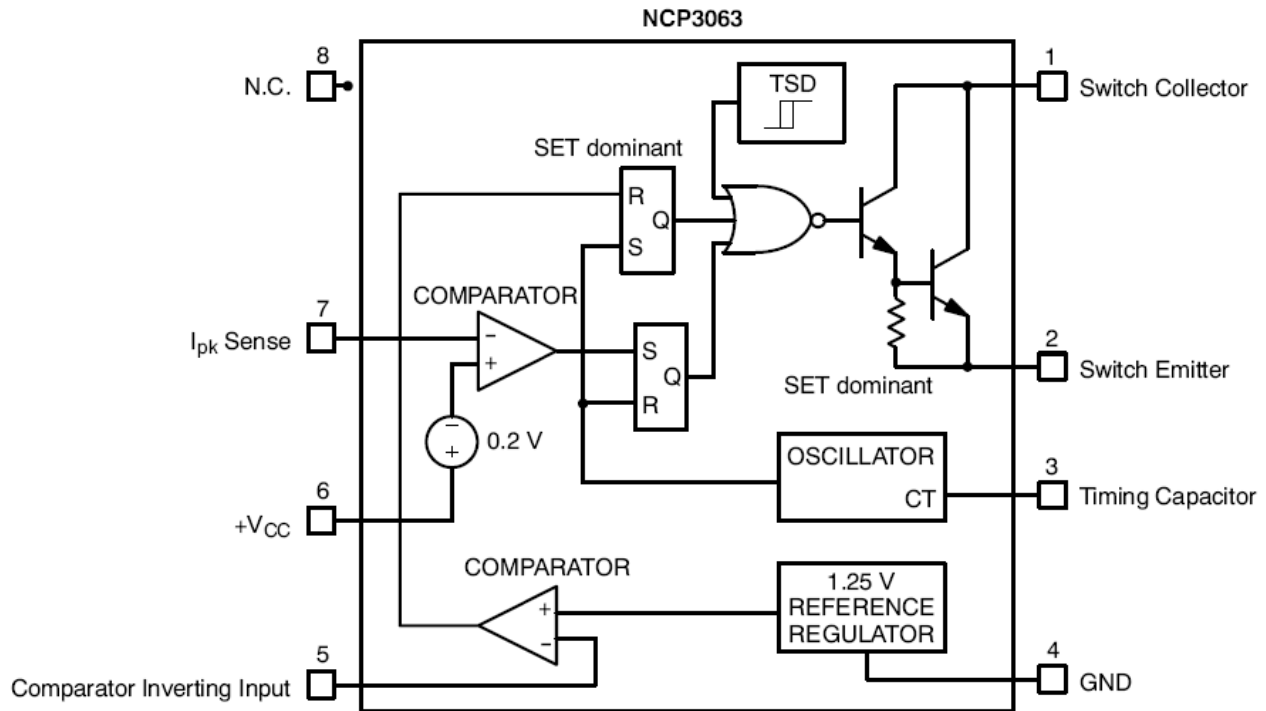

Figure 4 – NCP3063 Block Diagram

Table 2 – NCP3063 Pin Description

Pin No.	Pin Name	Description
1	Switch Collector	Internal Darlington switch collector
2	Switch Emitter	Internal Darlington switch emitter
3	Timing Capacitor Oscillator Input	Timing Capacitor
4	GND	Ground pin for all internal circuits
5	Comparator Inverting Input	Inverting input pin of internal comparator
6	V _{CC}	Voltage Supply
7	I _{pk} Sense	Peak Current Sense Input to monitor the voltage drop across an external resistor to limit the peak current through the circuit
8	N.C.	Pin Not Connected
Exposed Pad	Exposed Pad	The exposed pad beneath the package must be connected to GND (Pin 4). Additionally, using proper layout techniques, the exposed pad can greatly enhance the power dissipation capabilities of the NCP3063.

DN06042/D Performance Information

The following Figures show typical performance of the NCP3063 CLA evaluation board.

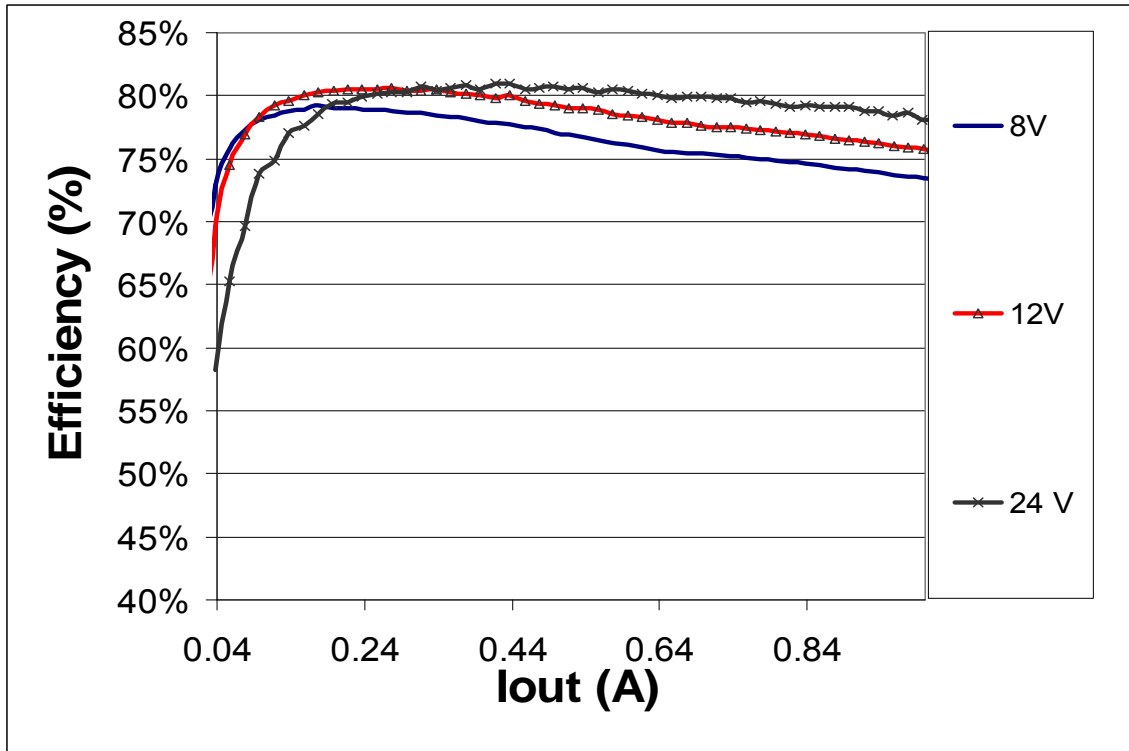

Figure 5– NCP3063 Efficiency 8V-24V with at 5V output Voltage.

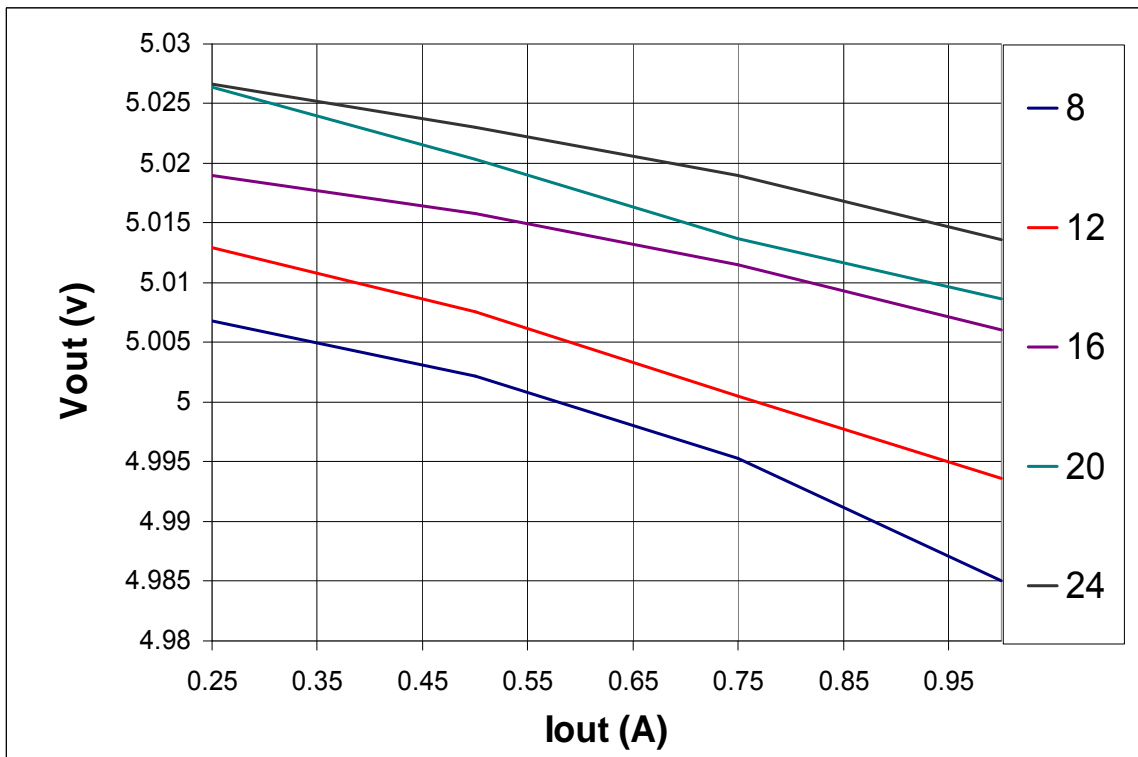

Figure 6 – NCP3063 Load Regulation

DN06042/D

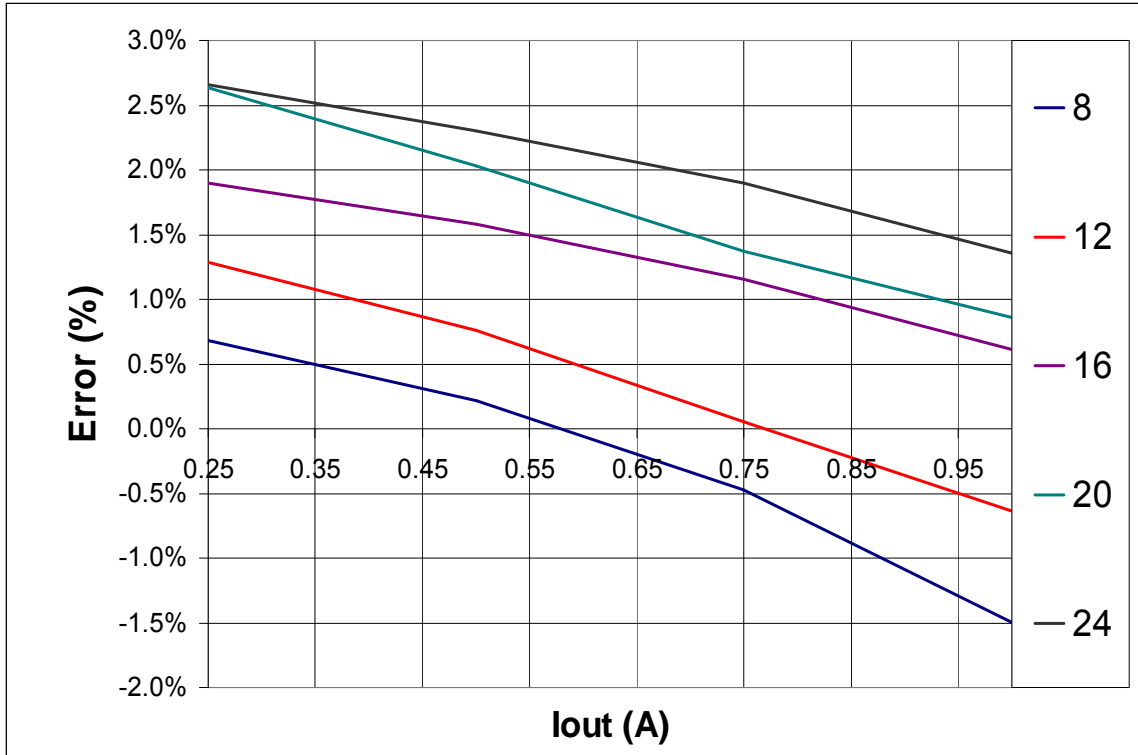

Figure 7 - NCP3063 Load Regulation Error

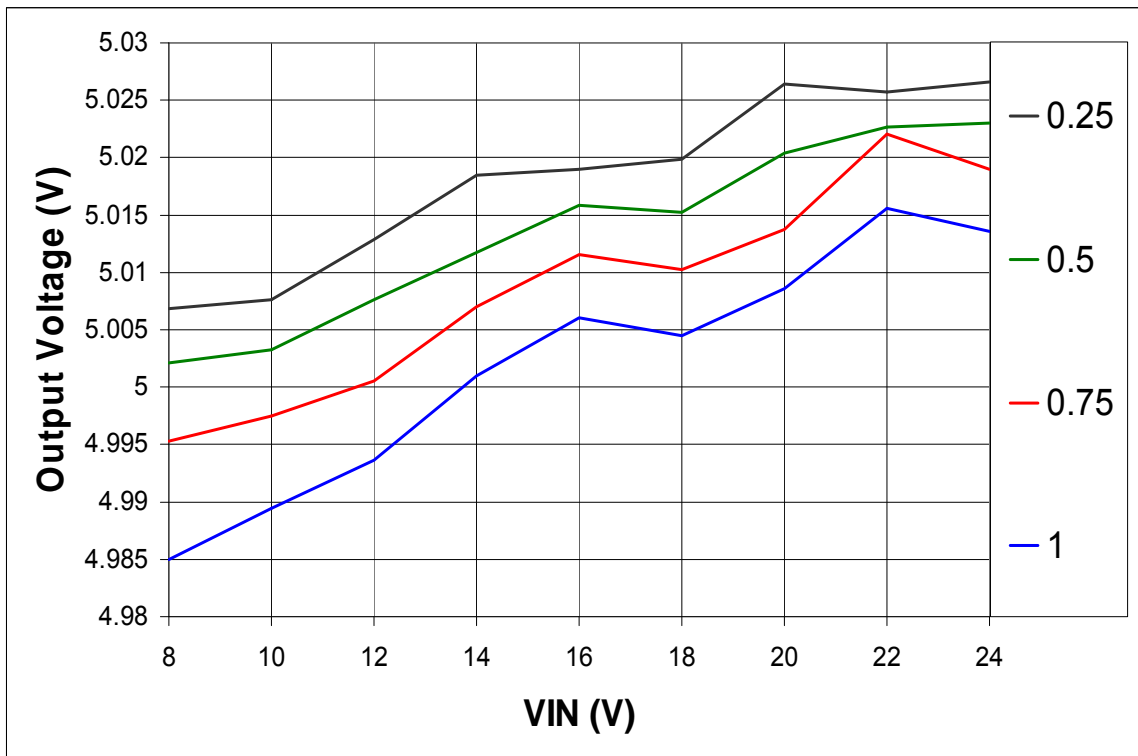

Figure 8 - NCP3063 Line Regulation

DN06042/D

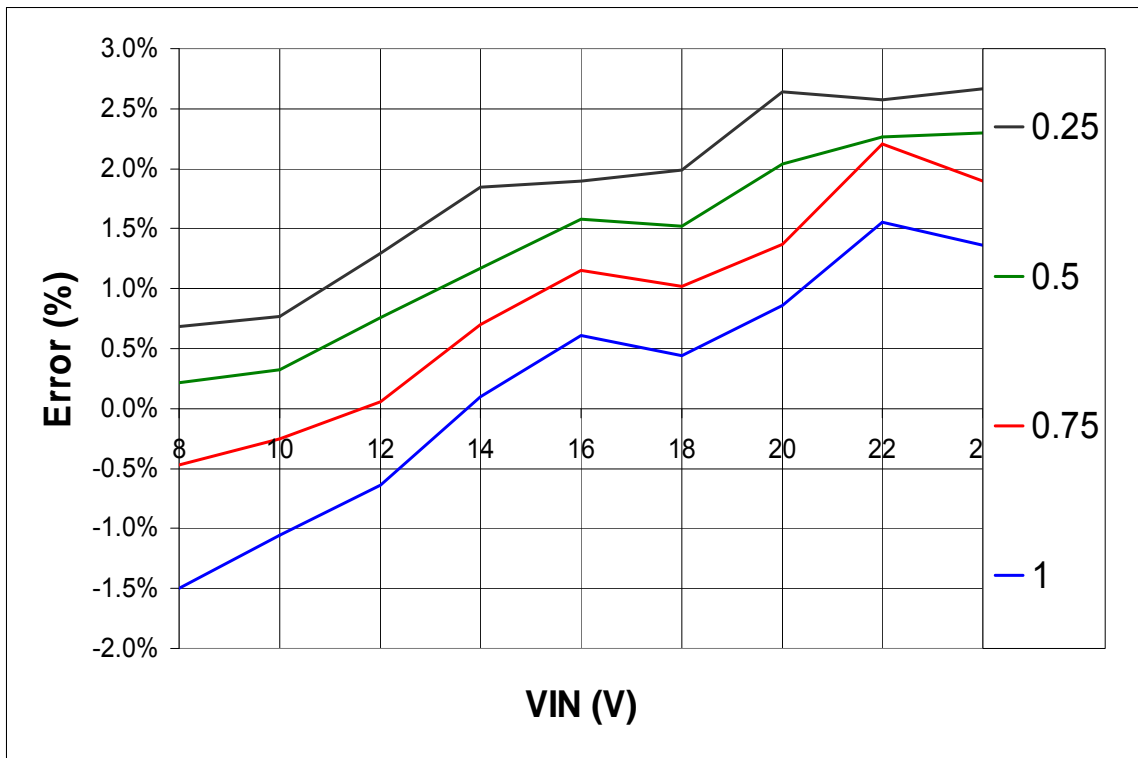

Figure 9 - NCP3063 Line Regulation Error

DN06042/D

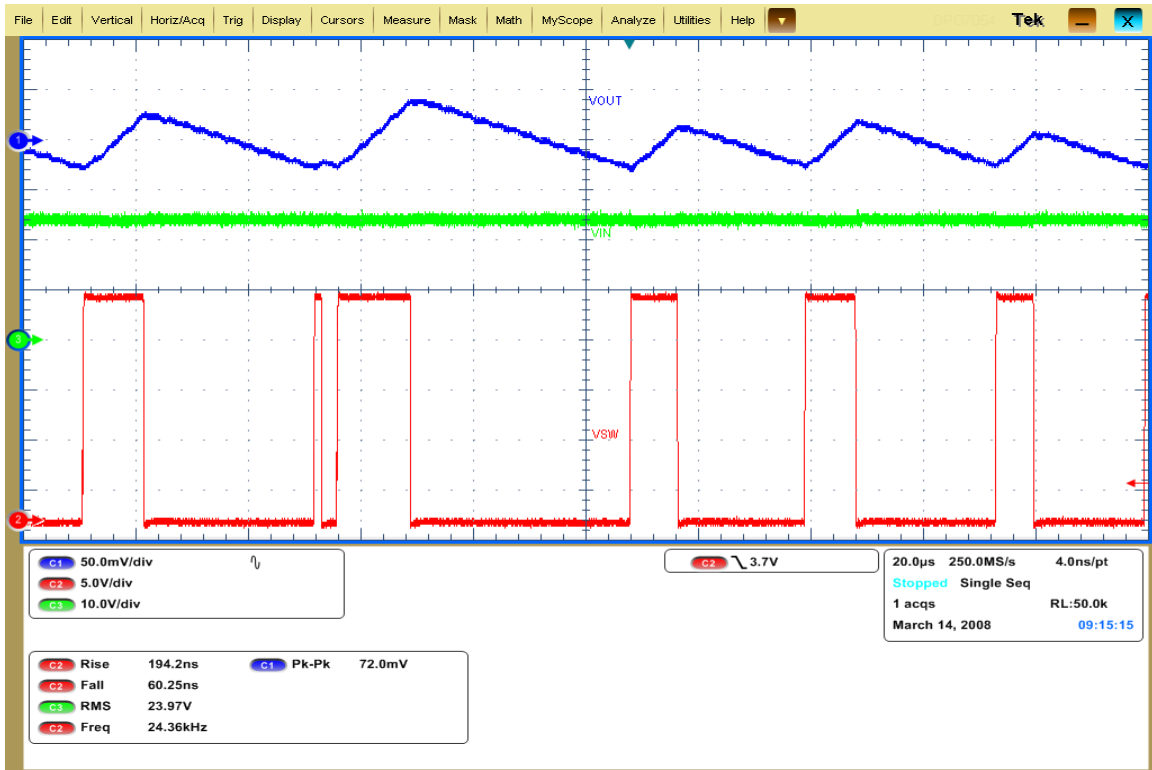

Figure 10- NCP3063 Output Ripple at 24 V to 5 V at a 1 A Load



Figure 11- NCP3063 Output Ripple at 24 V to 5 V at a no load

DN06042/D

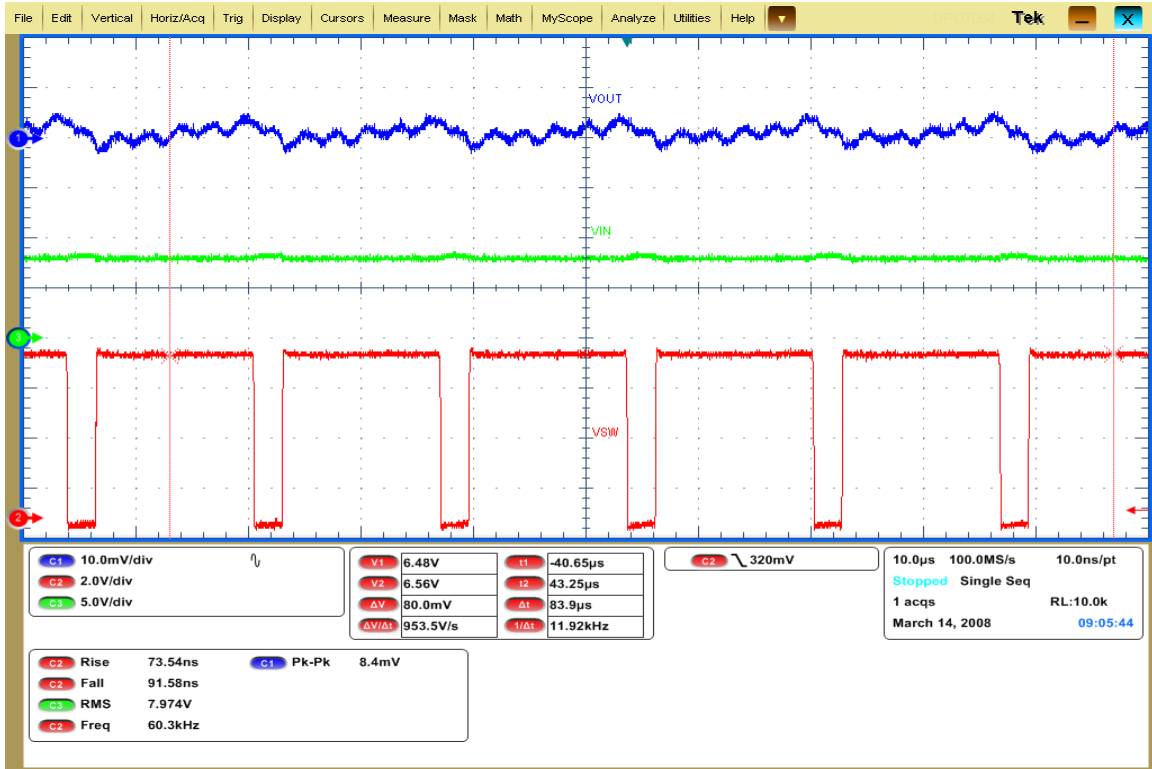

Figure 12- NCP3063 Output Ripple at 8 V to 5 V at a 1 A Load

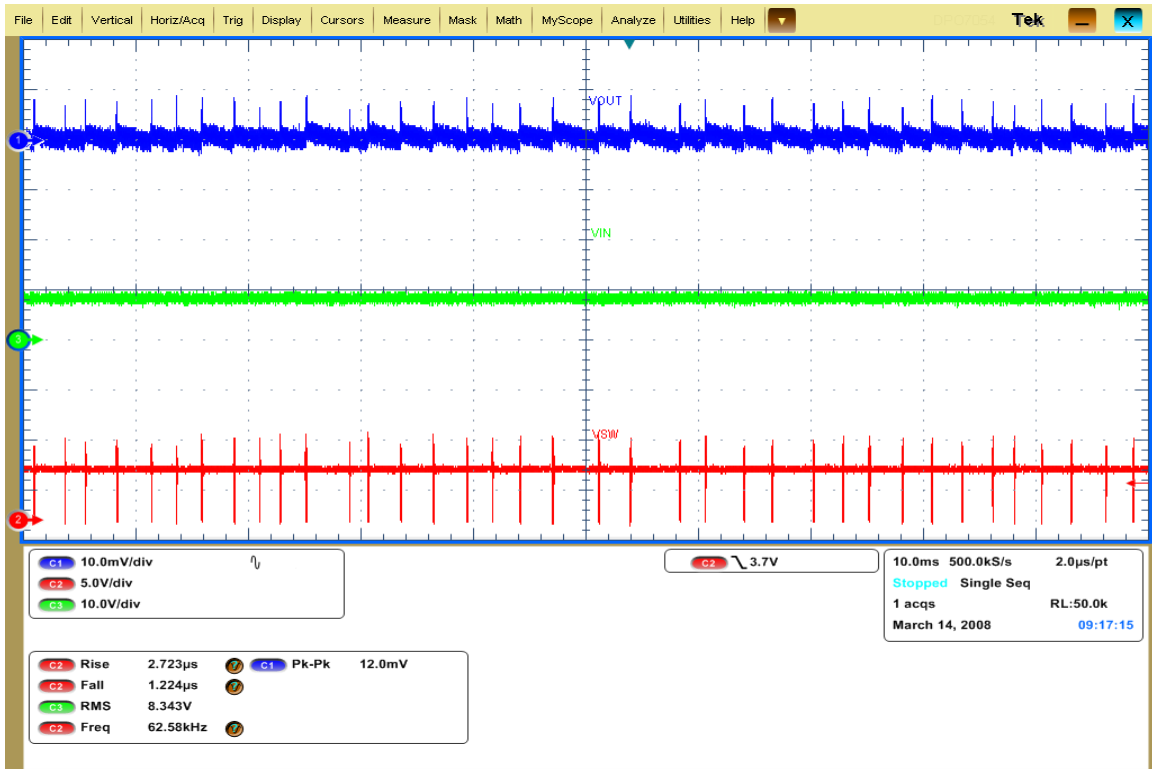

Figure 13- NCP3063 Output Ripple at 8 V to 5 V at a no load

DN06042/D

© 2008 ON Semiconductor.

Disclaimer: ON Semiconductor is providing this design note "AS IS" and does not assume any liability arising from its use; nor does ON Semiconductor convey any license to its or any third party's intellectual property rights. This document is provided only to assist customers in evaluation of the referenced circuit implementation and the recipient assumes all liability and risk associated with its use, including, but not limited to, compliance with all regulatory standards. ON Semiconductor may change any of its products at any time, without notice.

Design note created by Bryan McCoy and Tim Kaske, e-mail: bryan.mccoy@onsemi.com; tim.kaske@onsemi.com