

# NCP1081SPCGEVB

## Compact, high efficiency, 30 W Reference platform with the NCP1081 Evaluation Board User's Manual



ON Semiconductor®

<http://onsemi.com>

### EVAL BOARD USER'S MANUAL

#### Board Details

The NCP1081SPCGEVB implements a PoE power splitter that converts the voltage on the Ethernet cable to a lower voltage. The board is equipped with 2 RJ45 connectors, one connector serves as the data and power input and the other connector is the data output. Ethernet data is untouched by the board and simply forwarded.

#### Warnings

Close to the switching MOSFET voltages on the board may exceed 200 V (@250 kHz). Temperature of board and its components may exceed 85°C during normal operation. The Evaluation board was designed to operate correctly under these conditions.

The input voltage should never exceed 57 V nor should the evaluation board be loaded with loads higher than the specified 30 W. Exceeding the specified input and output values could permanently damage the board.

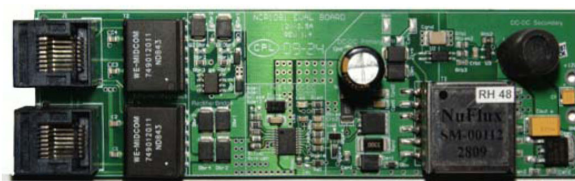

Figure 1. Front Side of EVB

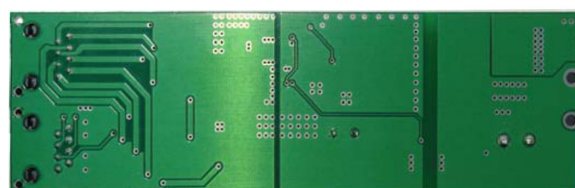

Figure 2. Back Side of EVB

Table 1. EVALUATION BOARD SPECIFICATIONS

Characteristic	Min	Typ	Max	Unit
Input Voltage, PoE Input	36	–	57	V
Output Voltage	–	12	–	V
Output Current	–	–	2.5	A
Oscillator Frequency	–	250	–	kHz
Output Ripple	–	–	170	mV
Efficiency	–	–	88	%

# NCP1081SPCGEVB

**Table 2. BOARD CONNECTOR DESCRIPTION**

Connector	Pin	Description
J4	1	TX+/BI_DA+, Data and Power Input, Pair 1, Mode A
	2	TX-/BI_DA-, Data and Power Input, Pair 1, Mode A
	3	RX+/BI_DB+, Data and Power Input, Pair 2, Mode A
	4	NC/BI_DC+, Data and Power Input, Pair 1, Mode B
	5	NC/BI_DC+, Data and Power Input, Pair 1, Mode B
	6	RX-/BI_DB-, Data and Power Input, Pair 2, Mode A
	7	NC/BI_DD+, Data and Power Input, Pair 2, Mode B
	8	NC/BI_DD-, Data and Power Input, Pair 2, Mode B
J1	1	TX+/BI_DA+, Data Output
	2	TX-/BI_DA-, Data Output
	3	RX+/BI_DB+, Data Output
	4	NC/BI_DC+, Data Output
	5	NC/BI_DC+, Data Output
	6	RX-/BI_DB-, Data Output
	7	NC/BI_DD+, Data Output
	8	NC/BI_DD-, Data Output
JOUT	12V	12 V Regulated Output
	GND	GND Regulated Output
	3	12 V Regulated Output

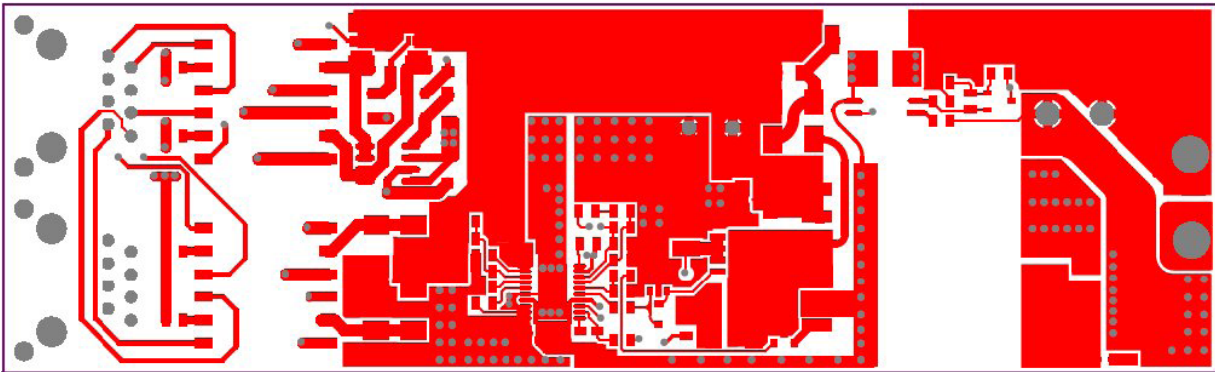

**Figure 3. Layout (Top)**

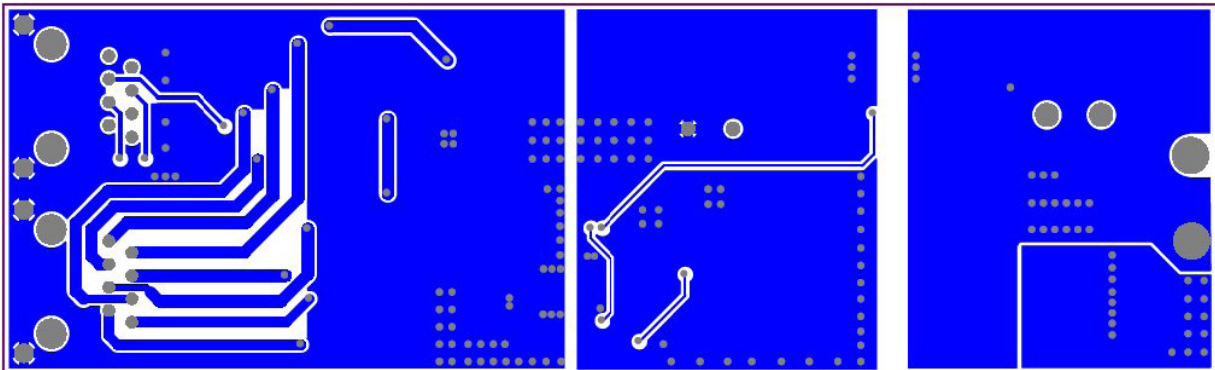

**Figure 4. Layout (Bottom)**

# NCP1081SPCGEVB

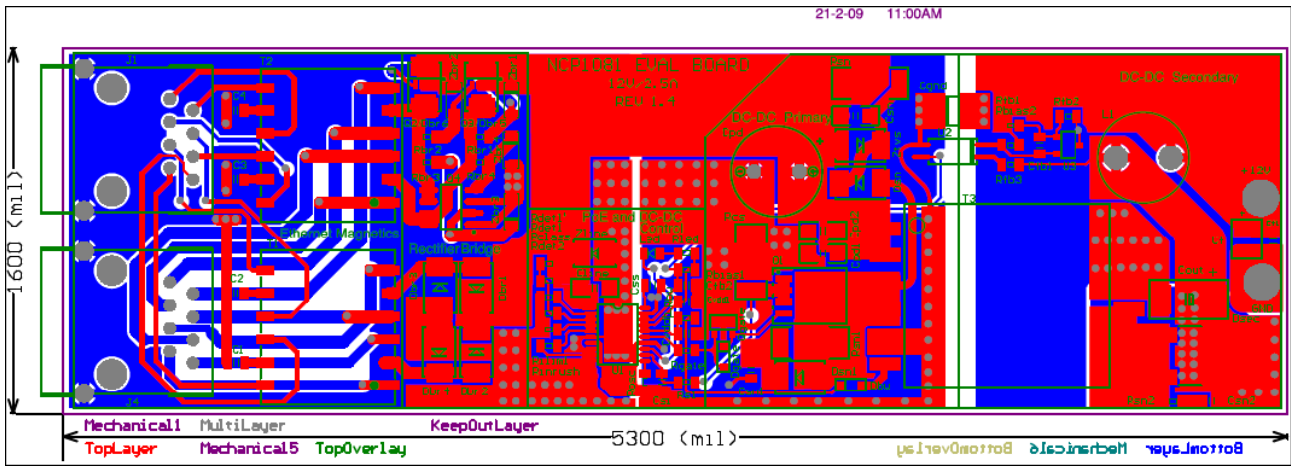

Figure 5. All Layers and Dimensions

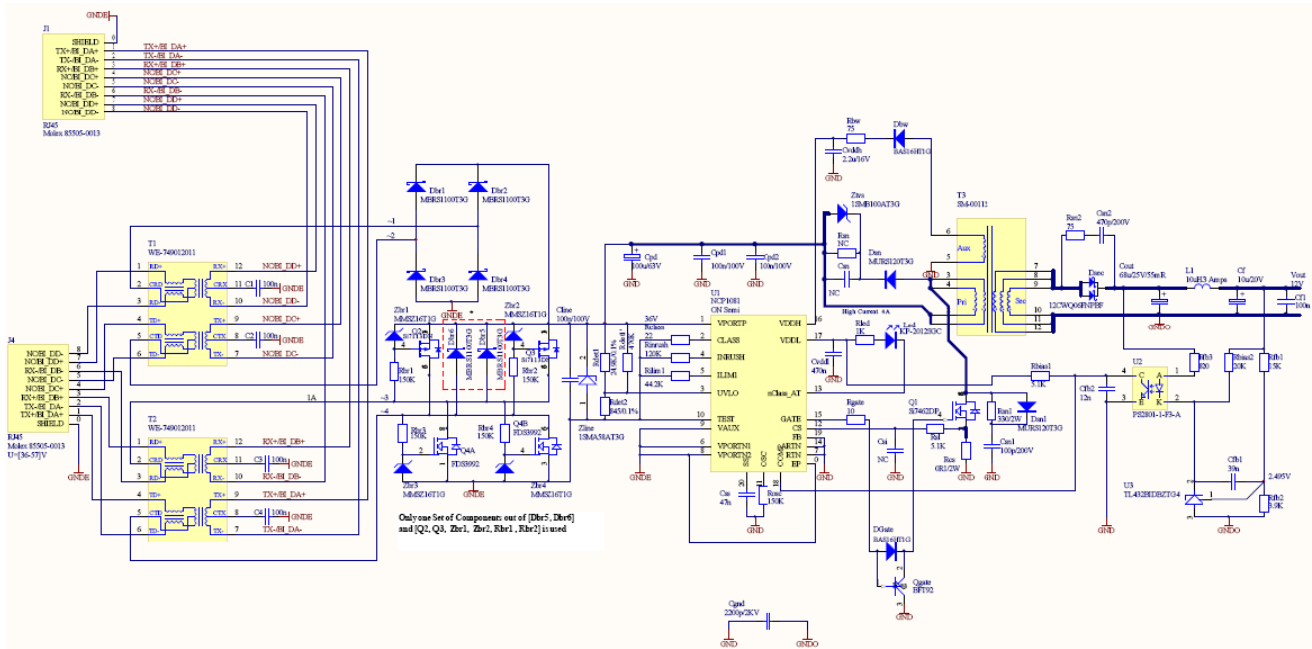

Figure 6. Schematic

# NCP1081SPCGEVB

**Table 3. BILL OF MATERIALS**

Designator	Quantity	Description	Value	Tolerance	Footprint	Manufacturer	Manufacturer Part Number	Substitution Allowed	Lead Free
U1	1	Power over Ethernet controller	NCP1081		TSSOPEP 20	ON Semiconductor	NCP1081DEG	No	Yes
C1, C2, C3, C4, Cf1	5	Capacitor SMD	100n/50V	10%	0805-C-S	Walsin	0805B104K500CT	Yes	Yes
Cf	1	Capacitor Polar	10u/20V	10%	C-TANT-B	AVX	TAJB106K020R	Yes	Yes
Cfb1	1	Capacitor SMD	39n/50V	10%	0805-C-S	AVX	08055C393KAT2A	Yes	Yes
Cfb2	1	Capacitor SMD	12n/50V	10%	0805-C-S	AVX	08055C123KAT2A	Yes	Yes
Cgnd	1	Capacitor SMD	2200p/2kV	10%	1812	Walsin	1812B222K202LT	Yes	Yes
Cline, Cpd1, Cpd2	3	Capacitor SMD	100n/100V	10%	1206-C	AVX	12061C104KAT2A	Yes	Yes
Cout	1	Capacitor Polar	68u/25V/5 5mR	10%	C-TANT-E	AVX	TPME686K025R0055	No	Yes
Cpd	1	Capacitor Polar	100u/63V	20%	CRD10.0L 17.0RM5.0	Hitano	EXR101M63	No	Yes
Csn1	1	Capacitor SMD	100p/200V	10%	0805-C-S	AVX	08052A101JAT2A	Yes	Yes
Csn2	1	Capacitor SMD	470p/200V	10%	0805-C-S	AVX	08052C47KJAT2A	Yes	Yes
Css	1	Capacitor SMD	47n/50V	10%	0805-C-S	AVX	08055C473KAT2A	Yes	Yes
Cvddh	1	Capacitor SMD	2.2u/16V	(+80%) to (-20%)	0805-C-S	AVX	0805YC225MAT2A	Yes	Yes
Cvddl	1	Capacitor SMD	470n/50V	10%	0805-C-S	AVX	08055C474KAZ2A	No	Yes
T3	1	PoE Plus Transformer	SM-00112		EFD20	NUFLUX	SM-00112	No	Yes
Dbr1, Dbr2, Dbr3, Dbr4, Dbr5, Dbr6,	6	SMD Schottky Rectifier	MBRS110 0T3G		403A-03	ON Semiconductor	MBRS1100T3G	No	Yes
Dbw, Dgate	2	SMD Switching Diode	BAS16HT 1G		SOD323	ON Semiconductor	BAS16HT1G	Yes	Yes
Dsec	1	SMD Schottky Rectifier	12CWQ06 FNPBF		DPAK	Vishay	12CWQ06FNPBF	No	Yes
Dsn, Dsn1	2	SMD Ultrafast Rectifiers	MURS120 T3G		403A-03	ON Semiconductor	MURS120T3G	No	Yes
Zbr3, Zbr4	2	SMD Zener	MMSZ16T 1G		SOD123	ON Semiconductor	MMSZ16T1G	Yes	Yes
Zline	1	SMD TVS Zener	1SMA58A T3G		SMA	ON Semiconductor / Multicomp	1SMA58AT3G / SMAJ58A	Yes	Yes
Ztvs	1	SMD TVS Zener	1SMB100 AT3G		403A-03	ON Semiconductor / Multicomp	1SMB100AT3G / SMAJ58A	Yes	Yes
J1, J4	2	8 Position 8 Contact (8P8C) modular jack communications connector	RJ45		95501-288 1	MOLEX	95501-2881	Yes	Yes
L1	1	Drum Core Choke	10uH/3A		10X12	Prismatic	9404037403	No	Yes

# NCP1081SPCGEVB

**Table 3. BILL OF MATERIALS**

Designator	Quantity	Description	Value	Tolerance	Footprint	Manufacturer	Manufacturer Part Number	Substitution Allowed	Lead Free
Led	1	LED	KP-2012S GC		0805-D-S	EVERLIGHT	17-21SYGC/S530-E2/TR8	Yes	Yes
Q1	1	MOSFET N-CHANNEL	Si7462DP		SOPP8	Vishay Siliconix	Si7462DP	No	Yes
Q4	1	MOSFET N-CHANNEL	FDS3992		SO-8	Fairchild	FDS3992	No	Yes
Qgate	1	Transistor PNP	BFT92		SOT23	Philips	BFT92	Yes	Yes
Rbias 1, Rsl	2	Resistor SMD	5.1k	5%	0805-R-S	Walsin	WR08X512JTL	Yes	Yes
Rbias 2	1	Resistor SMD	20k	1%	0805-R-S	Walsin	WR08X2002FTL	Yes	Yes
Rbr3, Rbr4, Rosc	3	Resistor SMD	150k	1%	0805-R-S	Walsin	WR08X1503FTL	Yes	Yes
Rbw, Rsn2	2	Resistor SMD	75	1%	0805-R-S	Walsin	WR08X750JTL	Yes	Yes
Rclas s	1	Resistor SMD	30.1	1%	0805-R-S	Yageo	RC0805FR-0730R1L	Yes	Yes
Rcs	1	Resistor SMD	0.1/3W	1%	2512-S	Bourns	CRA2512-FZ-R100ELF	Yes	Yes
Rdet1	1	Resistor SMD	24.9k	1%	0805-R-S	Walsin	WR08X2492FTL	Yes	Yes
Rdet2	1	Resistor SMD	845	1%	0805-R-S	Yageo	RC0805FR-07845RL	Yes	Yes
Rfb1	1	Resistor SMD	15k	1%	0805-R-S	Walsin	WR08X1502FTL	Yes	Yes
Rfb2	1	Resistor SMD	3.92k	1%	0805-R-S	Walsin	WR08X3921FTL	Yes	Yes
Rfb3	1	Resistor SMD	820	1%	0805-R-S	Yageo	RC0805FR-07820RL	Yes	Yes
Rgate	1	Resistor SMD	10	1%	0805-R-S	Walsin	WR08X10R0FTL	Yes	Yes
Rilim1	1	Resistor SMD	44.2K	1%	0805-R-S	Walsin	WR08X4422FTL	Yes	Yes
Rinru sh	1	Resistor SMD	121k	1%	0805-R-S	Walsin	WR08X1213FTL	Yes	Yes
Rled	1	Resistor SMD	1k	5%	0805-R-S	Yageo	RC080JR-07KL	Yes	Yes
Rsn1	1	Resistor SMD	330E /1W	5%	2512-S	Walsin	WR25X331JTL	Yes	Yes
T1, T2	2	WE-LAN SMD-10/100 BASE T	POE+ 350uH OCL 720mA IDC	2%	SMD	Würth-Elektronik	749012011	No	Yes
U2	1	HIGH ISOLATION VOLTAGE SSOP PHOTOCOUP LER	PS2801-1-F3-A		SSOP4	CEL	PS2801-1	No	Yes
U3	1	Programmable Shunt Voltage Reference	TL432BID BZTG4		SOT23	Texas-Instruments	TL432BIDBZTG4	No	Yes
Csi	1	Capacitor	NC		0805-C-S				
Csn	1	Capacitor	NC		1206-C				
Zbr1, Zbr2	2	SMD Zener	NC		SOD123	ON Semiconductor	MMSZ16T1G		
Rbr1, Rbr2	2	Resistor SMD	NC		0805-R-S				
Rdet1	1	Resistor SMD	NC		0805-R-S				
Rsn	1	Resistor SMD	NC		2512-S				
Q2, Q3	2	P-Channel 30V (D-S) MOSFET	NC		POWERP ACK 1212-8	Vishay	Si7113		

**onsemi**, **Onsemi**, and other names, marks, and brands are registered and/or common law trademarks of Semiconductor Components Industries, LLC dba "**onsemi**" or its affiliates and/or subsidiaries in the United States and/or other countries. **onsemi** owns the rights to a number of patents, trademarks, copyrights, trade secrets, and other intellectual property. A listing of **onsemi**'s product/patent coverage may be accessed at [www.onsemi.com/site/pdf/Patent-Marking.pdf](http://www.onsemi.com/site/pdf/Patent-Marking.pdf). **onsemi** is an Equal Opportunity/Affirmative Action Employer. This literature is subject to all applicable copyright laws and is not for resale in any manner.

The evaluation board/kit (research and development board/kit) (hereinafter the "board") is not a finished product and is not available for sale to consumers. The board is only intended for research, development, demonstration and evaluation purposes and will only be used in laboratory/development areas by persons with an engineering/technical training and familiar with the risks associated with handling electrical/mechanical components, systems and subsystems. This person assumes full responsibility/liability for proper and safe handling. Any other use, resale or redistribution for any other purpose is strictly prohibited.

**THE BOARD IS PROVIDED BY ONSEMI TO YOU "AS IS" AND WITHOUT ANY REPRESENTATIONS OR WARRANTIES WHATSOEVER. WITHOUT LIMITING THE FOREGOING, ONSEMI (AND ITS LICENSORS/SUPPLIERS) HEREBY DISCLAIMS ANY AND ALL REPRESENTATIONS AND WARRANTIES IN RELATION TO THE BOARD, ANY MODIFICATIONS, OR THIS AGREEMENT, WHETHER EXPRESS, IMPLIED, STATUTORY OR OTHERWISE, INCLUDING WITHOUT LIMITATION ANY AND ALL REPRESENTATIONS AND WARRANTIES OF MERCHANTABILITY, FITNESS FOR A PARTICULAR PURPOSE, TITLE, NON-INFRINGEMENT, AND THOSE ARISING FROM A COURSE OF DEALING, TRADE USAGE, TRADE CUSTOM OR TRADE PRACTICE.**

**onsemi** reserves the right to make changes without further notice to any board.

You are responsible for determining whether the board will be suitable for your intended use or application or will achieve your intended results. Prior to using or distributing any systems that have been evaluated, designed or tested using the board, you agree to test and validate your design to confirm the functionality for your application. Any technical, applications or design information or advice, quality characterization, reliability data or other services provided by **onsemi** shall not constitute any representation or warranty by **onsemi**, and no additional obligations or liabilities shall arise from **onsemi** having provided such information or services.

**onsemi** products including the boards are not designed, intended, or authorized for use in life support systems, or any FDA Class 3 medical devices or medical devices with a similar or equivalent classification in a foreign jurisdiction, or any devices intended for implantation in the human body. You agree to indemnify, defend and hold harmless **onsemi**, its directors, officers, employees, representatives, agents, subsidiaries, affiliates, distributors, and assigns, against any and all liabilities, losses, costs, damages, judgments, and expenses, arising out of any claim, demand, investigation, lawsuit, regulatory action or cause of action arising out of or associated with any unauthorized use, even if such claim alleges that **onsemi** was negligent regarding the design or manufacture of any products and/or the board.

This evaluation board/kit does not fall within the scope of the European Union directives regarding electromagnetic compatibility, restricted substances (RoHS), recycling (WEEE), FCC, CE or UL, and may not meet the technical requirements of these or other related directives.

FCC WARNING – This evaluation board/kit is intended for use for engineering development, demonstration, or evaluation purposes only and is not considered by **onsemi** to be a finished end product fit for general consumer use. It may generate, use, or radiate radio frequency energy and has not been tested for compliance with the limits of computing devices pursuant to part 15 of FCC rules, which are designed to provide reasonable protection against radio frequency interference. Operation of this equipment may cause interference with radio communications, in which case the user shall be responsible, at its expense, to take whatever measures may be required to correct this interference.

**onsemi** does not convey any license under its patent rights nor the rights of others.

LIMITATIONS OF LIABILITY: **onsemi** shall not be liable for any special, consequential, incidental, indirect or punitive damages, including, but not limited to the costs of requalification, delay, loss of profits or goodwill, arising out of or in connection with the board, even if **onsemi** is advised of the possibility of such damages. In no event shall **onsemi**'s aggregate liability from any obligation arising out of or in connection with the board, under any theory of liability, exceed the purchase price paid for the board, if any.

The board is provided to you subject to the license and other terms per **onsemi**'s standard terms and conditions of sale. For more information and documentation, please visit [www.onsemi.com](http://www.onsemi.com).

## ADDITIONAL INFORMATION

### TECHNICAL PUBLICATIONS:

Technical Library: [www.onsemi.com/design/resources/technical-documentation](http://www.onsemi.com/design/resources/technical-documentation)  
onsemi Website: [www.onsemi.com](http://www.onsemi.com)

### ONLINE SUPPORT: [www.onsemi.com/support](http://www.onsemi.com/support)

For additional information, please contact your local Sales Representative at [www.onsemi.com/support/sales](http://www.onsemi.com/support/sales)