

NCV8872SEPGVB

NCV887200 Automotive Grade High-Frequency SEPIC Controller Board Evaluation Board User's Manual



ON Semiconductor®

<http://onsemi.com>

EVAL BOARD USER'S MANUAL

Description

This NCV887200 evaluation board provides a convenient way to evaluate a high-frequency current-mode control SEPIC converter design. The topology uses two inductors. No additional components are required, other than dc supplies for the input and enable voltages. An external clock can be used to synchronize the switching frequency. The output is rated 12 V / 1.5 A with a 675 kHz switching frequency over the typical 6 V to 18 V automotive input voltage range.

Key Features

- 12 V / 1.5 A Output
- 675 kHz Switching Frequency (NCV887200)
- Input Undervoltage Lockout
- Internal Soft-Start
- Wide Input Voltage of 6 V to 40 V
- Regulates through 45 V Load Dump Conditions
- External Clock Synchronization up to 1.1 MHz
- Automotive Grade

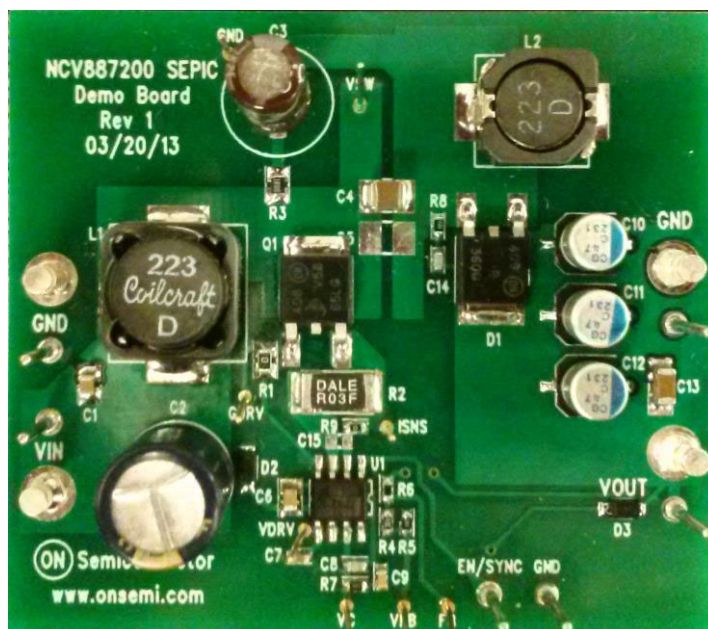

Figure 1. NCV887200 SEPIC Evaluation Board

NCV8872SEPGVB

Table 1. EVALUATION BOARD TERMINALS

Terminal	Function
VIN	Positive DC input voltage
GND	Common DC return
VOOUT	Regulated DC output voltage
EN/SYNC	Enable and synchronization input

Table 2. ABSOLUTE MAXIMUM RATINGS (Voltages are with respect to GND)

Rating	Value	Unit
DC Supply Voltage (VIN)	-0.3 to 40	V
DC Supply Voltage (EN, SYNC)	-0.3 to 6	V
Peak Transient Voltage (Load Dump on VIN)	45	V
Junction temperature	-40 to 150	°C
Ambient temperature (evaluation board)	-40 to 105	°C

Stresses exceeding Maximum Ratings may damage the device. Maximum Ratings are stress ratings only. Functional operation above the Recommended Operating Conditions is not implied. Extended exposure to stresses above the Recommended Operating Conditions may affect device reliability.

Table 3. ELECTRICAL CHARACTERISTICS

(TA = 25°C, 4.5 ≤ VIN ≤ 40 V, VEN = 2 V, VOUT = 3.3 V, 0 ≤ IOUT ≤ 1.2 A, unless otherwise specified)

Characteristic	Conditions	Typical Value	Unit
SWITCHING			
Switching Frequency	-	675	kHz
Soft-start Time	-	1.9	ms
SYNC Frequency range	-	675 – 1025	kHz
CURRENT LIMIT			
Cycle-by-cycle Current Limit (FET)	R _{sense} = 40 mΩ	5	A
PROTECTIONS			
Input Undervoltage Lockout (UVLO)	VIN decreasing	< 4.75*	V
Input Undervoltage Lockout (UVLO)	VIN increasing	5.23	V
Thermal Shutdown	TA increasing	170	°C
Short Circuit Threshold Voltage	VFB as % of Vref	67	%

*See Note 3 from Operating Guidelines

NCV8872SEPGVB

OPERATIONAL GUIDELINES

1. Connect a DC input voltage, within the 6 V to 40 V range, between VIN and GND.
2. Connect a DC enable voltage, within the 2.0 V to 5.0 V range, between EN/SYNC and GND.
3. The evaluation board feedback components were selected to for continuous operation at rated 12 V / 1.5 A output power at a minimum input voltage of 6 V. The NCV887200 V_{IN} has its operational voltage diode-ored between the converter output (12 V) and input voltages. The converter turns-on typically at 6.7 V. Once energized, the output voltage supplies power to the IC when the battery voltage is below (approximately) 11.5 V. The power supply will enter a hiccup soft-start mode if

4. Optionally for external clock synchronization, connect a pulse source between EN/SYNC and GND. The high state level should be within the 2 to 5 V range, and the low state level within the -0.3 V to 0.8 V range, with a minimum pulse width of 40 ns and a frequency within the 675 and 1100 kHz range.

NOTE: The converter was designed for 675 kHz 12 V / 1.5 A continuous mode operation. Operation beyond 675 kHz and/or at a different output voltage may require modifications of feedback loop component and inductor values.

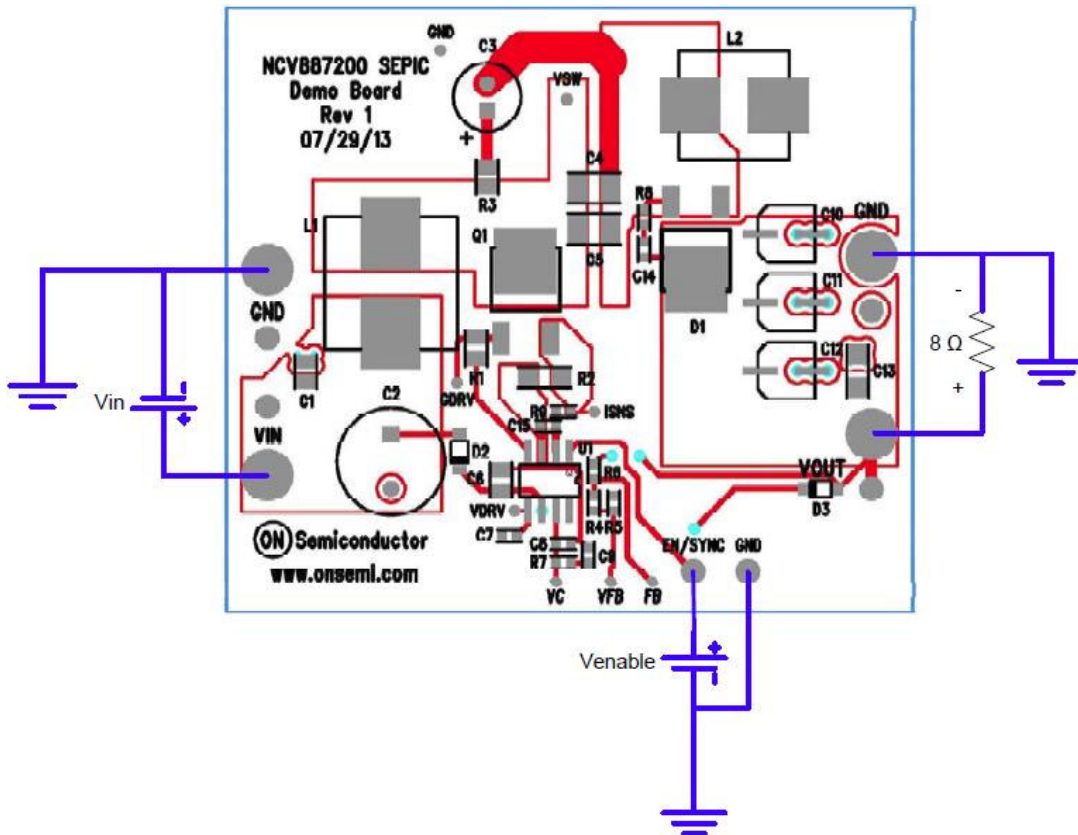

Figure 2. Evaluation Board Connections

NCV8872SEPGVB

TYPICAL PERFORMANCE

Start-up

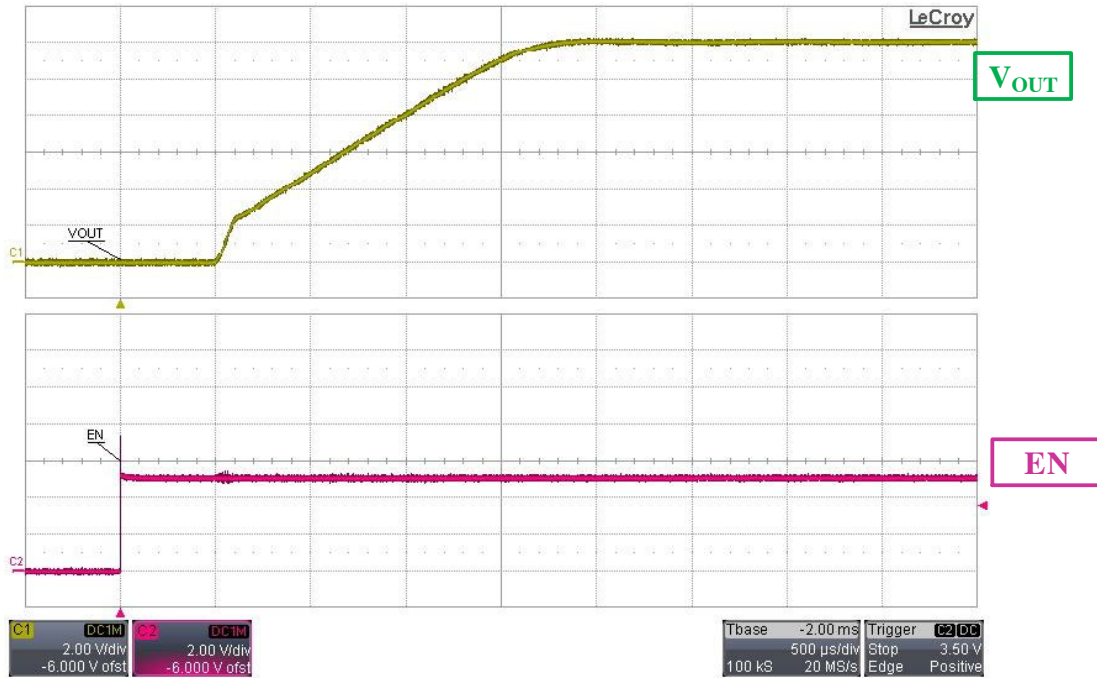

Figure 3. Typical Start-up with $V_{IN} = 12\text{ V}$, $I_{OUT} = 1\text{ A}$

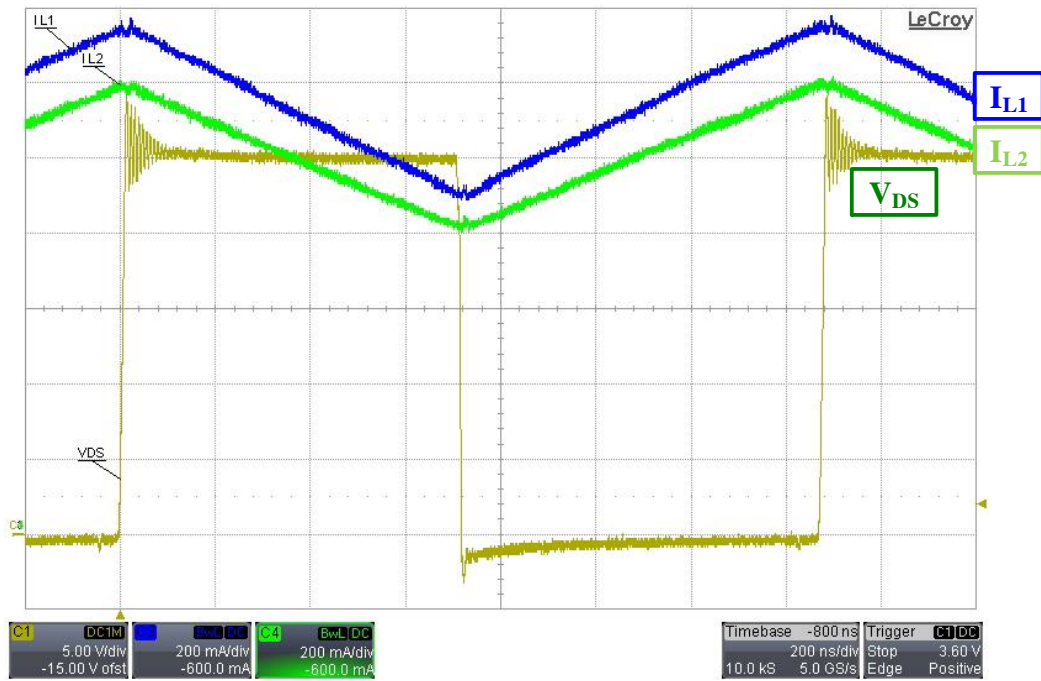

Figure 4. Operational Waveforms, $V_{IN} = 12\text{ V}$, $I_{OUT} = 1\text{ A}$

NCV8872SEPGVB

SCHEMATIC

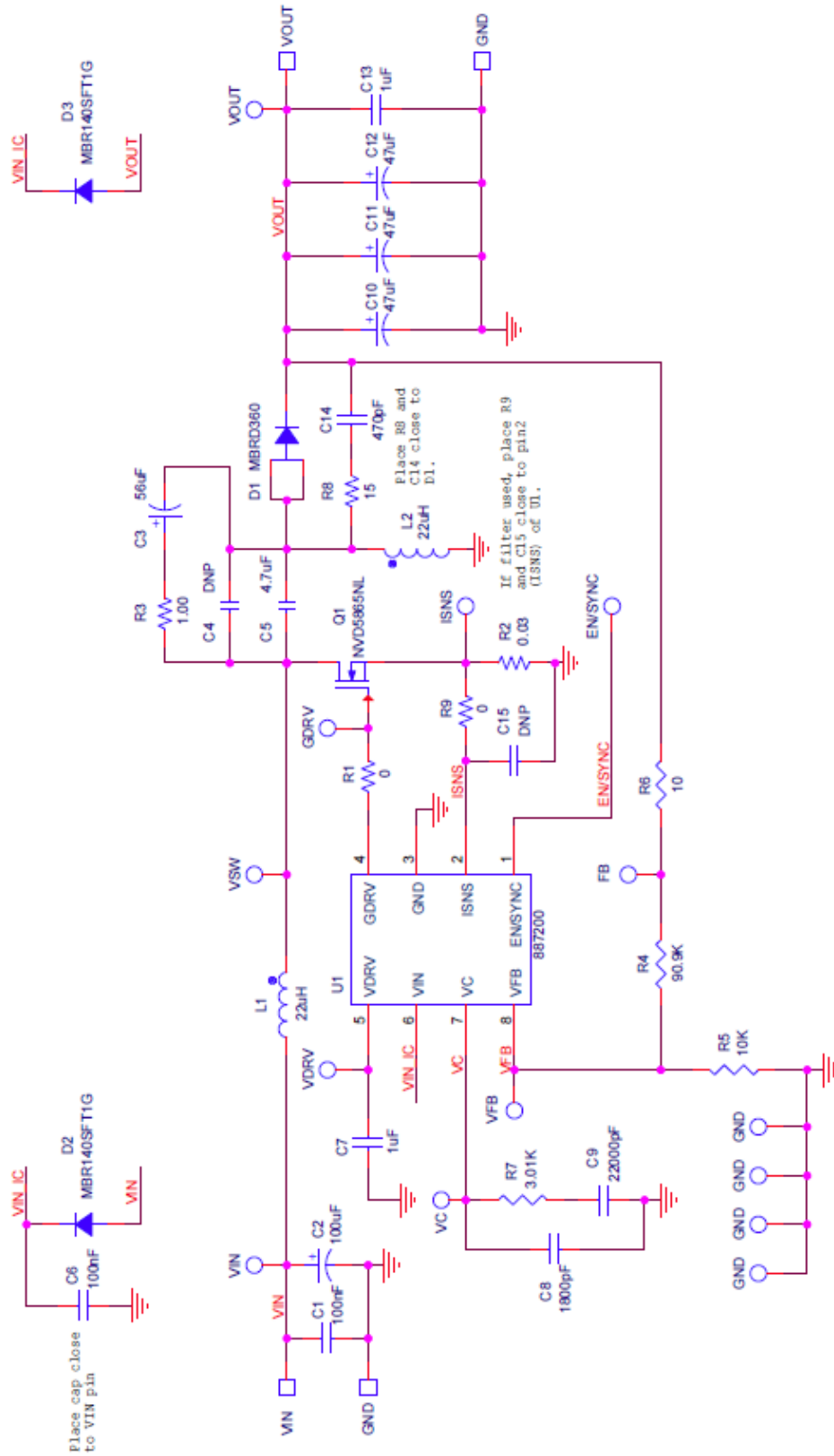

Figure 5. NCV887200 SEPIC Evaluation Board Schematic

NCV8872SEPGVB

PCB LAYOUT

NCV887200 SEP Demo Board Rev 1

03/05/13

TOP Layer

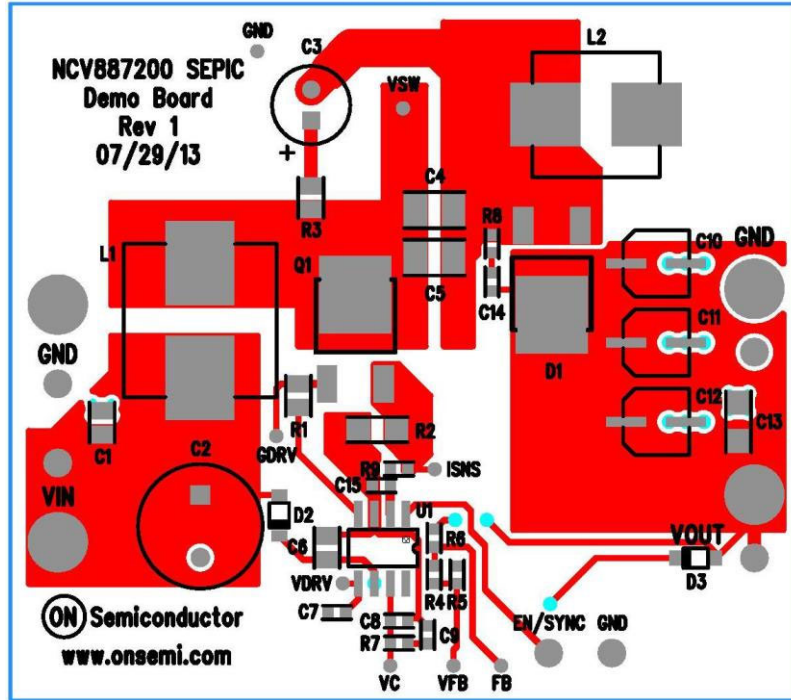

Figure 6. Top View

NCV887200 SEP Demo Board Rev 1

03/05/13

BOTTOM Layer (mirrored)

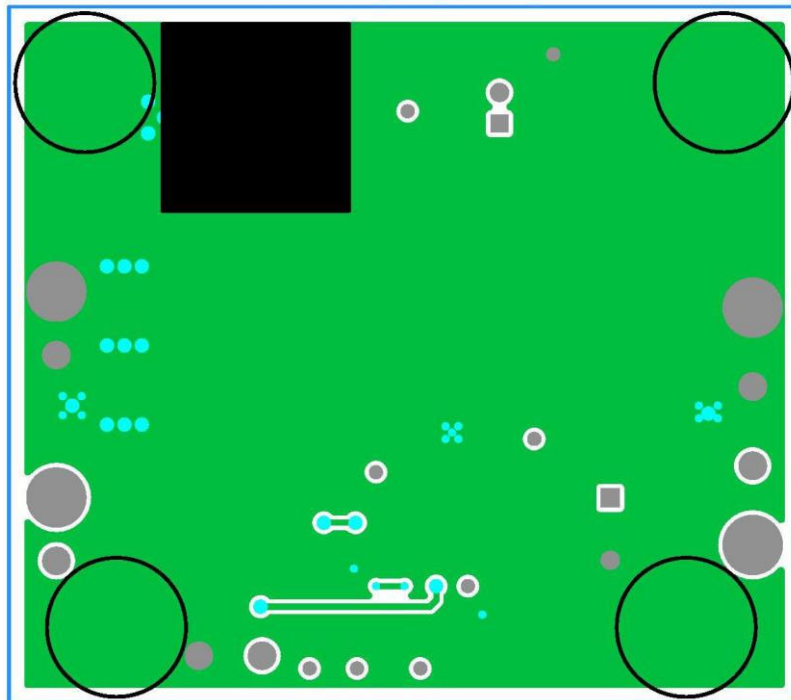

Figure 7. Bottom View

NCV8872SEPGVB

BILL OF MATERIALS

Table 4. BILL OF MATERIALS

Reference Designator(s)	Qty	Description	Value	Tolerance	Footprint	Manufacturer	Manufacturer's Part Number	Substitution Allowed	RoHS Compliant
C1, C6	2	CAP CER 0.1UF 50V 10% X7R 0805	100 nF	10%	805	TDK Corporation	CGA4J2X7R1H104K125AA	Yes	Yes
C2	1	CAP 100UF 50V ELECT FC RADIAL	100 uF	20%	FCA_CAP10X12p5	Panasonic - ECG	EEU-FC1H101	No	Yes
C3	1	CAP ALUM 56UF 50V 20% RADIAL	56 uF	20%	FCA_CAP6P3X11	Chem-Con	EKZE500ELL560MF11D	No	Yes
C4	1	CAP CER 4.7UF 50V 10% X7R 1210	4.7 uF	10%	1210	Murata Electronics North America	GRM32ER71H475KA88L	Yes	Yes
C5	DNP				1210			Yes	Yes
C7	1	CAP CER 1UF 16V X7R 10% 0603	1 uF	10%	603	Murata Electronics North America	GCM188R71C105KA64D	Yes	Yes
C8	1	CAP CER 1800PF 50V 5% NP0 0603	1800 pF	5%	603	TDK Corporation	CGA3E2C0G1H182J080AA	Yes	Yes
C9	1	CAP CER 0.022UF 16V 10% X7R 0603	22000 pF	10%	603	Murata Electronics North America	GRM188R71C223KA01D	Yes	Yes
C10, C11, C12	3	CAP POLY ALUM 47UF 16V SMD	47 uF	20%	CG_CAP5X6	Nichicon	PCG1C470MCL1GS	No	Yes
C13	1	CAP CER 1UF 50V X7R 1206	1 uF	10%	1206	Murata Electronics North America	GCM31MR71H105KA55L	Yes	Yes
C14	1	CAP CER 470PF 50V 5% NP0 0603	470 pF	5%	603	Murata Electronics North America	GCM1885C1H471JA16D	Yes	Yes
C15	DNP				603			Yes	Yes
D1	1	60 V, 3.0 A Schottky Rectifier DPAK	60 V / 3 A	N/A	DPAK3_DMD	ON Semiconductor	MBRD360G	No	Yes
D2, D3	2	DIODE SCHOTTKY 40V 1A SOD123FL	40 V / 1 A	N/A	SOD_123	ON Semiconductor	MBR140SFT1G	No	Yes
L1	1	High Temp SMT Power Inductor 2.3A	22 uH, 2.3 A	20%	COIL_MSS1260	Coilcraft Inc	MSS1246T-223ML	No	Yes
L2	1	High Temp SMT Power Inductor 1.9A	22 uH, 1.9 A	20%	COIL_MSS1038	Coilcraft Inc	MSS1038T-223ML	No	Yes
Q1	1	MOSFET N CH 60V DPAK-4	60 V / 38 A	N/A	DPAK3_DMD	ON Semiconductor	NVD5865NLT1G	No	Yes
R1	1	RES 0.0 OHM 1/8W JUMP 0805 SMD	0	N/A	805	Vishay/Dale	CRCW08050000Z0EA	Yes	Yes
R2	1	RES .03 OHM 1W 1% 1206 SMD	0.03	1%	1206	TT Electronics/Welwyn	LRMAM1206-R03FT5	Yes	Yes
R3	1	RES 1.00 OHM 1/8W 1% 0805 SMD	1	1%	805	Vishay/Dale	CRCW08051R00FKEA	Yes	Yes
R4	1	RES 90.9K OHM 1/10W 1% 0603 SMD	90.0 K	1%	603	Yageo	RC0603FR-0790K9L	Yes	Yes
R5	1	RES 10.0K OHM 1/10W 1% 0603 SMD	10.0 K	1%	603	Rohm Semiconductor	MCR03EZPFX1002	Yes	Yes
R6	1	RES 10.0 OHM 1/10W 1% 0603 SMD	10	1%	603	Yageo	RC0603FR-0710RL	Yes	Yes
R7	1	RES 3.01K OHM 1/10W 1% 0603 SMD	3.01 K	1%	603	Vishay/Dale	CRCW06033K01FKEA	Yes	Yes
R8	1	RES 15.0 OHM 1/10W 1% 0603 SMD	15	1%	603	Vishay/Dale	CRCW060315R0FKEA	Yes	Yes
R9	1	RES 0.0 OHM 1/10W JUMP 0603 SMD	0	N/A	603	Vishay/Dale	CRCW06030000Z0EA	Yes	Yes
TP1, 7, 14, 16, 17, 20	6	PIN INBOARD .042" HOLE 1000/PKG	N/A	N/A	TP	Vector Electronics	K24C/M	Yes	Yes

NCV8872SEPGVB

Table 4. BILL OF MATERIALS

Reference Designator(s)	Qty	Description	Value	Tolerance	Footprint	Manufacturer	Manufacturer's Part Number	Substitution Allowed	RoHS Compliant
TP2, 3, 5, 6, 8, 9, 15, 18	DNP	CIRCUIT PIN PRNTD .020"D .425"L	N/A	N/A	SMALLTP	Mill-Max Manufacturing Corp.	3128-2-00-15-00-00-08-0	Yes	Yes
TP10, 11, 12, 13	4	TERM SOLDER TURRET .219" .109"L	N/A	N/A	TURRET	Mill-Max Manufacturing Corp.	2501-2-00-44-00-00-07-0	Yes	Yes
U1	1	Automotive Non-Sync Boost Controller	N/A	N/A	SOIC8_N_ADJ	ON Semiconductor	NCV887200	No	Yes
Mounting Feet	4	BUMPON HEMISPHERE .44X.20 BLACK	N/A	N/A	0.44 inch circle	3M	SJ-5003 (BLACK)	Yes	Yes

onsemi, **Onsemi**, and other names, marks, and brands are registered and/or common law trademarks of Semiconductor Components Industries, LLC dba "**onsemi**" or its affiliates and/or subsidiaries in the United States and/or other countries. **onsemi** owns the rights to a number of patents, trademarks, copyrights, trade secrets, and other intellectual property. A listing of **onsemi**'s product/patent coverage may be accessed at www.onsemi.com/site/pdf/Patent-Marking.pdf. **onsemi** is an Equal Opportunity/Affirmative Action Employer. This literature is subject to all applicable copyright laws and is not for resale in any manner.

The evaluation board/kit (research and development board/kit) (hereinafter the "board") is not a finished product and is not available for sale to consumers. The board is only intended for research, development, demonstration and evaluation purposes and will only be used in laboratory/development areas by persons with an engineering/technical training and familiar with the risks associated with handling electrical/mechanical components, systems and subsystems. This person assumes full responsibility/liability for proper and safe handling. Any other use, resale or redistribution for any other purpose is strictly prohibited.

THE BOARD IS PROVIDED BY ONSEMI TO YOU "AS IS" AND WITHOUT ANY REPRESENTATIONS OR WARRANTIES WHATSOEVER. WITHOUT LIMITING THE FOREGOING, ONSEMI (AND ITS LICENSORS/SUPPLIERS) HEREBY DISCLAIMS ANY AND ALL REPRESENTATIONS AND WARRANTIES IN RELATION TO THE BOARD, ANY MODIFICATIONS, OR THIS AGREEMENT, WHETHER EXPRESS, IMPLIED, STATUTORY OR OTHERWISE, INCLUDING WITHOUT LIMITATION ANY AND ALL REPRESENTATIONS AND WARRANTIES OF MERCHANTABILITY, FITNESS FOR A PARTICULAR PURPOSE, TITLE, NON-INFRINGEMENT, AND THOSE ARISING FROM A COURSE OF DEALING, TRADE USAGE, TRADE CUSTOM OR TRADE PRACTICE.

onsemi reserves the right to make changes without further notice to any board.

You are responsible for determining whether the board will be suitable for your intended use or application or will achieve your intended results. Prior to using or distributing any systems that have been evaluated, designed or tested using the board, you agree to test and validate your design to confirm the functionality for your application. Any technical, applications or design information or advice, quality characterization, reliability data or other services provided by **onsemi** shall not constitute any representation or warranty by **onsemi**, and no additional obligations or liabilities shall arise from **onsemi** having provided such information or services.

onsemi products including the boards are not designed, intended, or authorized for use in life support systems, or any FDA Class 3 medical devices or medical devices with a similar or equivalent classification in a foreign jurisdiction, or any devices intended for implantation in the human body. You agree to indemnify, defend and hold harmless **onsemi**, its directors, officers, employees, representatives, agents, subsidiaries, affiliates, distributors, and assigns, against any and all liabilities, losses, costs, damages, judgments, and expenses, arising out of any claim, demand, investigation, lawsuit, regulatory action or cause of action arising out of or associated with any unauthorized use, even if such claim alleges that **onsemi** was negligent regarding the design or manufacture of any products and/or the board.

This evaluation board/kit does not fall within the scope of the European Union directives regarding electromagnetic compatibility, restricted substances (RoHS), recycling (WEEE), FCC, CE or UL, and may not meet the technical requirements of these or other related directives.

FCC WARNING – This evaluation board/kit is intended for use for engineering development, demonstration, or evaluation purposes only and is not considered by **onsemi** to be a finished end product fit for general consumer use. It may generate, use, or radiate radio frequency energy and has not been tested for compliance with the limits of computing devices pursuant to part 15 of FCC rules, which are designed to provide reasonable protection against radio frequency interference. Operation of this equipment may cause interference with radio communications, in which case the user shall be responsible, at its expense, to take whatever measures may be required to correct this interference.

onsemi does not convey any license under its patent rights nor the rights of others.

LIMITATIONS OF LIABILITY: **onsemi** shall not be liable for any special, consequential, incidental, indirect or punitive damages, including, but not limited to the costs of requalification, delay, loss of profits or goodwill, arising out of or in connection with the board, even if **onsemi** is advised of the possibility of such damages. In no event shall **onsemi**'s aggregate liability from any obligation arising out of or in connection with the board, under any theory of liability, exceed the purchase price paid for the board, if any.

The board is provided to you subject to the license and other terms per **onsemi**'s standard terms and conditions of sale. For more information and documentation, please visit www.onsemi.com.

ADDITIONAL INFORMATION

TECHNICAL PUBLICATIONS:

Technical Library: www.onsemi.com/design/resources/technical-documentation
onsemi Website: www.onsemi.com

ONLINE SUPPORT: www.onsemi.com/support

For additional information, please contact your local Sales Representative at www.onsemi.com/support/sales