

Offline LED Driver Intended for ENERGY STAR[®] Residential LED Luminaire Applications



ON Semiconductor[®]

<http://onsemi.com>

TECHNICAL NOTE

Overview

This reference document describes a built-and-tested, GreenPoint[®] solution for an isolated 8 W constant current LED driver which is intended to support the residential power factor requirements of the DoE ENERGY STAR Standard for Solid State Lighting Luminaires (Version 1.1 – 12/19/08). Some of the typical products in this category include portable desk lamps, under-cabinet lights, and outdoor porch lights.

One of the most common power supply topologies for low power offline LED drivers is an isolated flyback topology. Unfortunately standard design techniques used for these supplies typically result in a power factor in the range of 0.5–0.6. This design note describes why the power factor is low and discusses techniques to improve the power factor. Finally it illustrates how an existing design was modified to substantially improve the power factor and easily comply with the residential power factor requirements.

Background

The NCP1014LEDGTGEVB evaluation board has been optimized to drive 1–8 high power high brightness LEDs such as the Cree XLAMP[®] XR-E/XP-E, Luxeon[™] Rebel, Seoul Semiconductor Z-POWER[®], or OSRAM Golden Dragon[™]. The design is built around the NCP1014, a compact fixed frequency PWM converter which integrates a high voltage power switch with internal current limiting.

Since the converter is limited to a maximum power of approximately 8 W with a universal AC input (90 – 265 Vac), the number of LEDs which can be driven is a function of the drive current. Specifically for this design note, the load will be one Cree XLAMP MC-E driven at 630 mA where all LEDs are connected in series. The MC-E is comprised of 4 LEDs mounted in a single package and the maximum rated current per LED is 700 mA. The evaluation board can be modified for other LED drive currents by making slight modifications to the bill of materials.

A typical off-line flyback power converter utilizes a full wave bridge rectifier and substantial bulk capacitance preceding the switching regulator. This configuration is chosen because twice every line cycle the line power reduces and ultimately reaches zero before rising to the next peak.

The bulk capacitor fills in the missing power providing a more constant input to the switching regulator maintaining power flow to the load.

This configuration comes at the expense of poor utilization or power factor of the input line waveform. Line current is drawn in high amplitude narrow pulses near the peaks of the voltage waveform introducing disruptive high frequency harmonics. Passive solutions are well documented but typically introduce many additional components. One approach is the valley-fill type rectifier where a collection of electrolytic capacitors and diodes increases the line frequency conduction angle resulting in improved power factor. In effect, this process charges the series-connected capacitors from the high line voltage at low current and discharges them to the switching regulator at a lower voltage with higher current. A typical application uses two capacitors and three diodes or, for enhanced power factor performance, three capacitors and six diodes.

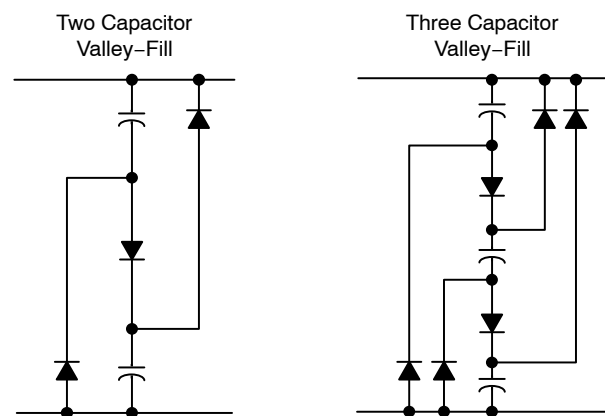

Figure 1. Valley Fill Circuits

While the valley-fill rectifier improves the utilization of the line current, it does not provide a constant input to the switching regulator. Power delivered to the load will have significant ripple at twice the line power frequency. Note that the 4 diodes rectifying the line power are still needed bringing the total number of diodes for this solution to 7 or

10. These diodes and multiple electrolytic capacitors add cost, degrade reliability and consume considerable circuit board area.

Another solution is an active power factor boost stage such as the NCP1607B situated before the flyback converter. This approach provides superior power factor with typical performance > 0.98 , but it comes with increased parts count, reduced efficiency and increased complexity. This approach is most suitable at power levels well above the modest power level of this application.

Approach

High power factor requires generally sinusoidal line current and minimal phase displacement between the line current and voltage. The first step is to have minimal capacitance before the switching stage to allow a more sinusoidal input current. This allows the rectified voltage to follow the line voltage resulting in a more desirable sinusoidal input current flow. The input voltage to the flyback converter now follows a rectified sine shape at twice the line frequency. If the input current is kept to the same shape, the power factor will be high. The energy delivered to the load will follow the product of voltage and current which is a sine-squared shape. As a result of this sine-squared energy transfer, the load will experience ripple at twice the line frequency similar in nature to the ripple seen with a valley fill circuit.

As mentioned above, the input current must be kept to a nearly sinusoidal shape to achieve high power factor. The key to this is not allowing the control loop to correct for output ripple by holding the feedback input at a constant level with respect to the line frequency. One option is to significantly increase the output capacitance to reduce the amount of 120 Hz ripple, an approach which some applications may require. LEDs for general lighting are more tolerant to ripple provided the frequency is above the visible optical perception range. The more compact and less costly way is to filter the feedback signal going back to the PWM converter establishing a nearly constant level. This level fixes the maximum current in the power switch. The current in the power switch is determined by the applied instantaneous input voltage divided by the transformer primary inductance times the length of time the power switch is conducting. Since the NCP1014 operates at a fixed frequency, the current cannot rise beyond a certain point as determined by the input voltage and primary inductance before the end of the switching period or conduction time. As a result of the conduction time limitation, the input current will follow the shape of the input voltage providing improved power factor.

The fixed feedback level represents the current in the power switch corresponding to the point where the proper average energy is transferred to the LED over a complete half cycle of line input. Achieving this fixed feedback level requires nothing more than increasing the feedback capacitor C6 to the point that any correction made by optocoupler U2 is averaged below the line frequency allowing only compensation for LED voltage and RMS line voltage variations and not ripple present on the output. The schematic is shown in Figure 2.

The single stage converter is not without caveats. As mentioned, energy is transferred to the secondary in a sine-squared shape. The flyback transformer must couple this energy and therefore be capable of processing peak power $\sim 1.4x$ the average delivered power. The core may be larger than a conventional flyback transformer design approach. Moreover, the peak ripple must be below the maximum rating of the LEDs. Increasing the filter capacitor integrates the pulsating power delivered to the secondary and provides more constant current level to the LED load. The capacitance can be tailored to limit ripple current. In this case, 2000 μF is sufficient to limit ripple to less than 25% which is 2x what the non-power factor corrected demo board design (NCP1014LEDR2GEVB) utilizes.

Note that while the power supply was designed to meet agency requirements, it has not been submitted for compliance. Standard safety practices should be used when this circuit is energized and in particular when connecting test equipment. During evaluation, input power should be sourced through an isolation transformer.

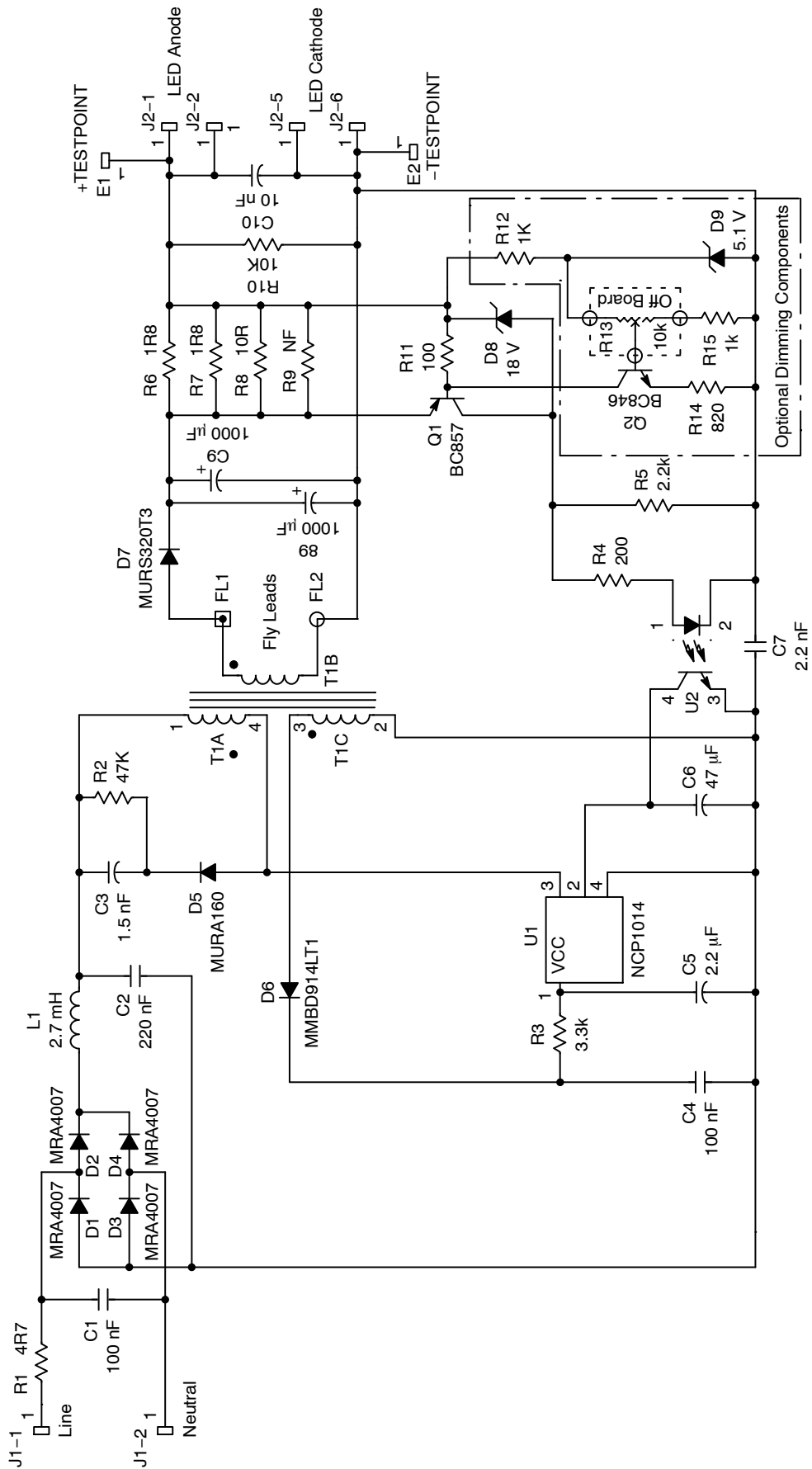

Figure 2. Schematic of NCP1014LEDGTGEVB

Design Procedure

Higher switching frequency reduces transformer size but at the same time increases switching losses. These factors create a minimum loss point depending on exact transformer design and selected semiconductors. In this case, the 100 kHz version of NCP1014 was chosen as the balance point. Efficiency for this monolithic converter is expected to be about 75%; therefore input power of 10.6 W is expected for the 8 W output. Input operating range is 90 to 265 Vac.

The NCP1014 includes ON Semiconductor's DSS or Dynamic Self Supply circuit which simplifies start up by reducing parts count. Thermal considerations of this integrated controller determine the maximum output power. A copper area on the circuit board will dissipate heat and reduce the temperature. A bias winding on the flyback transformer disables the DSS when the converter is running and reduces dissipation in the converter. Lower operating temperature enables more power to be delivered to the load.

EMI Filter

Switching regulators draw pulsing current from the input source. Requirements on harmonic content (see references) restrict the high frequency content of power supply input current. Typically a filter comprised of capacitors and inductors attenuates undesirable signals. Capacitors connected across the input lines conduct a current which is 90° out of phase with the input voltage. This shifted current degrades power factor by displacing the phase between the input voltage and current. A balance must be reached between the need for filtering and maintaining high power factor.

Given the nature of electromagnetic interference and complex characteristics of filter components a starting point of 100 nF for C1 and C2 was chosen. The differential inductor L1 was chosen to provide an L-C filter frequency of about one tenth the switching frequency. The following formula for inductor value was used:

$$L = \frac{(1/2\pi * 0.1 * f_{sw})^2}{C} = \frac{(1/2\pi * 0.1 * 100000)^2}{100 \text{ nF}} = 2.5 \text{ mH}$$

Select 2.7 mH which is a standard value. From this starting point, the filter was adjusted empirically to meet conducted emissions limits. C2 was increased to 220 nF providing margin on emissions limit. R1 limits the inrush current and provides a fusible element in the event of a fault. A fuse may be required to meet safety requirements depending on the application environment. Note the inrush current is low given the small total primary capacitance.

Primary Clamp

D5, C3, and R2 form a clamp network to control voltage spiking due to leakage inductance of the flyback transformer. D5 should be a fast recovery device rated for peak input voltage plus the output voltage reflected to the transformer primary. Maximum input voltage is 265 V ac or 374 V peak. The transformer turns ratio is 105:20. Given a maximum output voltage of 22 V (the open circuit voltage),

the reflected primary voltage is $22 * (105/20) = 115.5 \text{ V}$. Adding the peak input to the reflected voltage yields 489.5 V. Allow ~10 V for inductive voltage spike or 500 V total. This is well below the 700 V maximum rating of the internal switch. Peak current is limited to the NCP1014 current limit which is 450 mA. The fast recovery MURA160 is rated for 1 A at 600 V and is a good choice for the diode.

Capacitor C3 must absorb the leakage energy with little increase in voltage. 1.5 nF is adequate for this low power application. Resistor R3 must dissipate the leakage energy but not unnecessarily degrade efficiency. This resistor was empirically selected as 47 kΩ. Note this resistor and capacitor must be rated for $115.5 + 10 = 125.5 \text{ V}$.

Bias Supply

D6 rectifies the power delivered by the bias winding. Voltage stress on D6 is set by the peak input voltage times the transformer turns ratio plus the primary bias voltage. The peak input was previously determined as 374 V. The turns ratio is 105:13 therefore the voltage due to primary input is $374 * (13/105) = 46.3 \text{ V}$. The maximum output voltage of 22 V is reflected to set the primary bias voltage. $22 * (13/20) = 14.3 \text{ V}$. D6 reverse voltage is the sum of these two or 60.6 V. MMBD914 is rated 100 V at 200 mA and is a good choice for this rectifier as the operating current of the NCP1014 is less than 1.2 mA.

Primary bias is filtered by C4, R3, and C5. Since the sine squared power transfer of this flyback regulator does not provide constant energy to the primary bias, the DSS circuit can activate and introduce visible flicker. To avoid this, the primary bias must be allowed to discharge partially each half cycle. C5 was chosen as 2.2 μF to allow this voltage movement. C4 acts as a peak filter with 0.1 μF. R3 limits the maximum voltage presented to the NCP1014. This converter has a protection mode which monitors the primary bias for excessive voltage. Selecting R3 as 1.5 kΩ avoids activating this protection feature which is not needed in this application.

Output Rectifier

The output rectifier must carry peak currents well in excess of the average output current of 630 mA. A rectifier with low forward voltage and fast recovery time will minimize losses. Maximum reverse voltage will occur at the peak of maximum input voltage. This voltage is scaled by the turns ratio of the transformer. The output voltage is added to this peak switching voltage resulting in peak reverse voltage stress. The maximum output voltage is 22 V. Therefore the peak rectifier voltage is $374 * (20/105) + 22 \text{ V} = 93.2 \text{ V}$. The MURS320 is a 3 A, 200 V, 35 nS rectifier providing low forward drop and fast switching. As mentioned, the output capacitance of 2000 μF will limit the output ripple current to 25% or 144 mA peak-to-peak.

Current Control

Constant average current output is maintained by monitoring the voltage drop across R_{sense} , a resistor in series with the output. Resistor R11 connects the sense resistor to the base-emitter junction of a general purpose PNP transistor Q1. Current through R11 biases Q1 on when the voltage drop on R_{sense} is ~ 0.6 V. Q1 establishes a current flow through the LED of an optical coupler and is limited by R4. The transistor of the optical coupler U2 provides feedback to the NCP1014 converter controlling the output current.

Q1 regulates the peaks of the load current. With a ripple current of 25% peak to peak the peak current is $\sim 12\%$ higher than the average. As a result, the LED current will follow this relationship:

$$I_{out} = \left(\frac{Q1 V_{be}}{R_{sense}} \right) / 1.12$$

Given $V_{be} = 0.6$ V then $R_{sense} = 0.536 / I_{out}$

Setting $I_{out} = 630$ mA requires $R_{sense} = 0.85 \Omega$. R_{sense} is comprised of four paralleled elements, R6–R9 which is a lower cost solution than a single power resistor and allows the value to be easily modified to support other LED current values if needed. Selecting R6 and R7 as 1.8Ω , R8 as 10Ω and leaving R9 open yields 0.83Ω . Note that the output current is temperature sensitive as Q1 base-emitter voltage varies -2 mV/ $^{\circ}$ C so the output current should be set based on typical operating conditions.

Power Factor Control

Maintaining high power factor in this circuit relies on a slow feedback response time allowing only a slight change in feedback level over a given half cycle of input power. For this current mode control device that means maximum peak current will be almost constant over a half cycle. This improves power factor compared to a traditional feedback system which attempts to minimize output ripple by increasing switching current as input voltage decreases and reducing current when input voltage increases. Capacitor C6 provides the slow loop response by working against the internal 18 k Ω pullup resistor of the NCP1014 and the current drawn from the feedback optical coupler transistor. C6 was empirically determined in the range of 22 μ F to 47 μ F.

Transformer

This LED driver is required to run at a minimum input of 90 V ac which is 126 V peak. In this flyback application, the peak switching current follows the equation below where $P_o = 8$ W output, $\eta =$ efficiency = 0.75 , and $V_{in} = 126$ V:

$$I_{pk} = \frac{(4 * P_o)}{(\eta * V_{in})} = \frac{(4 * 8 \text{ W})}{(0.75 * 126 \text{ V})} = 0.339 \text{ A}$$

From this peak current the primary inductance is calculated using 100 kHz for f_{SW} .

$$L_p = \frac{(500 * V_{in})}{(I_{pk} * f_{SW})} = \frac{(500 * 126 \text{ V})}{(0.339 \text{ A} * 100)} = 1858 \mu\text{H}$$

An E16 core with an area $A_c = 0.2$ cm 2 is a good choice for this power level. Maximum flux density is set at 3 kG to minimize losses in a high temperature environment. Primary turns can be calculated using the following formula:

$$N_p = \frac{(0.1 * L_b * I_{pk})}{(A_c * B)} = \frac{(0.1 * 1858 \mu\text{H} * 0.339 \text{ A})}{(0.2 \text{ cm}^2 * 3 \text{ kG})} = 105 \text{ T}$$

There is considerable latitude in selecting the turns ratio for the secondary winding. The limitations are the maximum voltage applied to the power switch and limiting the duty cycle to 50% . The NCP1014 is rated for 700 V and applying a derating factor of 80% nets a maximum allowable stress of 560 V. Maximum input voltage was previously established as 374 V which leaves $560 \text{ V} - 374 \text{ V} = 186$ V. Subtracting the 10 V for spike leaves 176 V maximum across the primary winding.

The output voltage is limited to 22 V for protection in the event of an open load condition. This value is increased by 50% to 33 V providing some margin on output voltage and lower duty cycle. Minimum number of secondary turns will then follow this formula:

$$N_s = N_p * \left(\frac{V_{sec}}{V_{pri}} \right) = 105 * \left(\frac{33 \text{ V}}{176 \text{ V}} \right) \approx 20 \text{ Turns}$$

The NCP1014 needs a minimum of 8.1 V to keep the DSS feature from activating while the converter is running, which helps reduce dissipation as previously mentioned. Minimum LED voltage is designed for 12.5 V. The primary bias voltage will then follow the formula below for number of turns.

$$N_b = N_s * \left(\frac{V_{bias}}{V_{sec}} \right) = 20 * \left(\frac{8.1 \text{ V}}{12.5 \text{ V}} \right) \approx 13 \text{ Turns}$$

Transformers intended to meet safety isolation often include insulated margins in the windings. This amounts to physical spacers keeping primary and secondary windings separated. These spacers severely limit the winding volume in small transformers. An alternate approach to safety isolation is triple-insulated wire. This type of wire is approved for direct contact from primary to secondary circuits. While not as thin as conventional magnet wire, using this on a winding with a small number of turns often provides a design which allows larger wire and therefore less loss for a given size core. The secondary winding in this transformer is based on triple-insulated wire resulting in a compact low-loss design.

The bobbin pins on small transformers are often very close to the core. As such, some safety agency guidelines do not accept the spacing as adequate for proper isolation. Flying leads are used in this design to avoid this potential issue. The triple-insulated wire exits the winding area and

connects to the PCB in a location far enough away from the transformer to satisfy safety spacing requirements.

Special bobbin designs are available on the market from suppliers like Würth-Midcom which provide the required safety spacing without the need for flying leads. This type of bobbin could be a benefit in some applications.

Open Load Protection

A zener diode provides open load protection. Should the output voltage increase beyond the knee voltage of D8 plus the forward voltage of the LED in the optical coupler, current will flow issuing a feedback signal to the NCP1014 protecting against excessive output voltage. Open load voltage is set by the sum of voltage of D8, drop across R4, and the LED in the opto-coupler. D8 was selected as 18 V establishing about 22 V maximum output to maintain output current control over the forward voltage range of the MC-E LED array with some margin within the capabilities of the NCP1014. Higher output voltages are possible with selection of higher voltage rated capacitors and output rectifier but will require a reduction in output current to maintain about an 8 W maximum load.

Bleeder and Filter

R10 and C10 provide a small discharge path and noise filtering of the output. The LEDs should always be connected before the circuit is energized as the output capacitors can store a significant amount of energy and this would be discharged through the LEDs at the moment of connection. The output capacitors store a significant amount of energy which will be discharged through the LEDs at the moment of connection. The resultant current surge could damage the LEDs immediately or result in latent damage which ultimately will shorten the anticipated long life of the LEDs.

Analog Dimming

This reference design has an optional control section which implements analog current adjustment for dimming. Components R12, R14, R15, D9, Q2, and a connection to potentiometer R13 can be added to the board for this purpose. When the voltage drop of R_{sense} plus the drop across R11 equals the base-emitter threshold, Q1 turns on and provides the feedback signal to the NCP1014. Introducing a bias across R11 will reduce the required voltage and therefore current through R_{sense} and the LED load. The LED dimming control scheme is designed to introduce an offset in R11. Since the common mode voltage present on R11 changes with temperature and LED configuration a simple resistor biasing network will perform poorly as a dimming control. This can be addressed by passing a controlled current through R11 to develop a voltage drop independent of the common mode voltage resulting in more predicable dimming behavior. Varying the bias current changes the voltage drop across R11. In this way, varying the controlled current through R11 will have an inverse effect on the current delivered to the load.

Q2 and surrounding components form a constant current source to bias R11 for dimming. Zener D9 establishes a set voltage at the top of dimming potentiometer R13. This voltage is divided by the potentiometer and applied to the base of Q2. The gain of Q2 is high therefore the base current is negligible and consequently the base voltage will be set by the potentiometer. A nearly constant base-emitter voltage on Q2 means the emitter voltage also tracks the potentiometer voltage and is impressed on R14. This voltage divided by the resistance of R14 establishes a current through R14 which is a function of the potentiometer setting. Given the assumption of high gain, the collector of Q2 will have nearly the same current as R14. The result is the collector of Q2 draws a nearly constant current through R11 as set by the potentiometer.

The current through R11 and thus Q2 must be bounded to provide optimal performance. The LED output current is reduced by Q2 current therefore setting the maximum Q2 current will establish the minimum output current. The minimum output current is established when the potentiometer delivers the full D9 voltage of 5.1 V to the base of Q2. R14 will be 0.6 V less due to the Q2 emitter base voltage resulting in 4.5 V impressed across it. Selecting 50 mA as the minimum LED current results in $50 \text{ mA} * 0.83 \Omega = 42 \text{ mV}$ across R_{sense} . Subtracting 42 mV from the Q1 base-emitter voltage of 600 mV leaves 558 mV across R11 representing a required current of $558 \text{ mV} / 100 \Omega = 5.58 \text{ mA}$. R14 maximum voltage of $4.5 \text{ V} / 5.58 \text{ mA} = 806 \Omega$. Select 820 Ω for R14.

To ensure maximum brightness, no offset current should flow through R11. In other words, Q2 should be completely shut off. The lowest setting of the potentiometer should be below the minimum base-emitter voltage of Q2, but not so low as to create a significant portion of the adjustment travel with no visible change in LED brightness. The formula below defines the minimum control voltage at the base of Q2.

$$R15 = \left(\frac{R13 * V_{base}}{VD9 - V_{base}} \right)$$

Setting the voltage to 0.5 V is a good starting point.

$$R15 = \left(\frac{10000 * 0.5}{5.1 - 0.5} \right) = 1.09 \text{ k}\Omega$$

Rounding R15 down ($R15 = 1 \text{ k}\Omega$) will ensure no loss of LED current as the transistors heat up.

Capacitor Lifetime

One of the considerations of LED lighting is that the driver and LEDs should have a comparable operating life. While power supply reliability is influenced by multiple factors, the electrolytic capacitors are critical to the overall reliability of any electronic circuit. Analyzing the capacitors in the application and selecting the proper electrolytic capacitors is essential for long operating life. Useful life of an electrolytic capacitor is strongly affected by ambient temperature and internal temperature rise due to ripple

current acting on internal resistance. The manufacturer's rated life of an electrolytic capacitor is based on exposure to maximum rated temperature with maximum rated ripple current applied. A typical capacitor rated lifetime might be 5000 hours at 105°C. Operating stresses lower than the rated levels will exponentially increase the useful life of the capacitor. While choosing capacitors with long rated life and high temperature rating enhances operating life, capacitors rated for lower temperature and shorter life may still be suitable depending on the stress and operating temperature resulting in a lower cost solution. Formulae for useful life can be found on manufacturer's websites.

Useful capacitor life follows this equation:

$$L = \left(L_r * 2^{\left(\frac{T_{max} - T_{san}}{10} \right)} \right) * \left(K^{\left(\left(1 - \left(\frac{I_{rpl}}{I_{max}} \right)^2 \right) * \frac{T_{cr}}{10} \right)} \right)$$

Where:

- L = calculated useful life
- L_r = rated life
- T_{max} = rated temperature
- T_{san} = surrounding normalized temperature
- I_{rpl} = measured ripple current, I_{max} = rated ripple current
- T_{cr} = capacitor core temperature rise
- K is equal to 2 for applications where ripple current is below rated current. For an ambient temperature of 55°C, set T_{cr} = 30°C.

The capacitors selected for this application are the Panasonic ECA-1EM102 which is rated 1000 µF, 25 V, 850 mA, 2000 hr, and 85°C. Assign a 50°C ambient as T_{san}. Worst case measured ripple for the pair of output capacitors is 740 mA rms or 370 mA per capacitor. Substituting parameters in the equation above yields:

$$L = \left(2000 * 2^{\left(\frac{85 - 50}{10} \right)} \right) * \left(2^{\left(\left(1 - \left(\frac{0.37}{0.85} \right)^2 \right) * \frac{30}{10} \right)} \right) = 122\,069\text{ hours}$$

The capacitor lifetime is in line with the requirements for LED lighting based on the expected operating temperature.

Test Results

Data was collected on the NCP1014LEDGTGEVB with a load of 4 LEDs operating at approximately 630 mA unless otherwise stated. Tests were conducted in prevailing lab environment after a one hour warm up period. Figures 3 and 4 show efficiency as a function of output load and applied input voltage respectively.

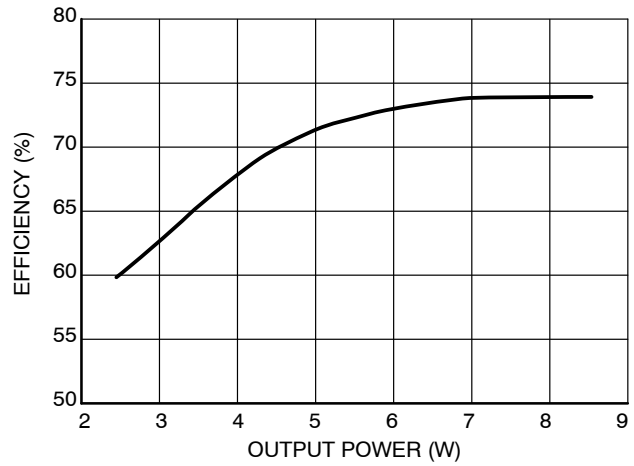

Figure 3. Efficiency Across Output Load with V_{in} = 115 Vac

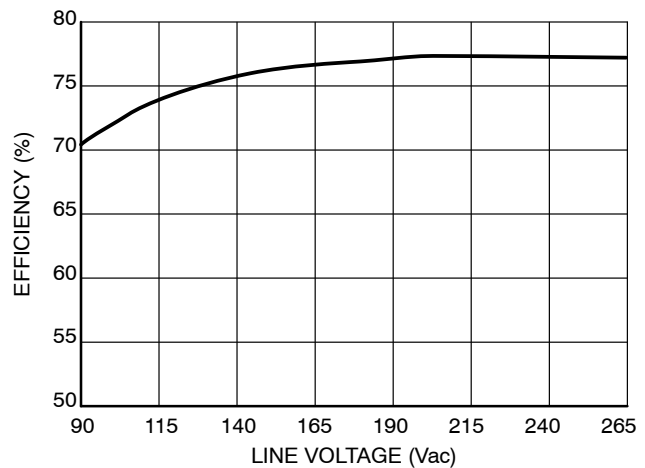

Figure 4. Efficiency Across Line Voltage with P_{out} = 8.5 W

Output power of the LED driver is characterized from open circuit condition through short circuit on the output. The intended operating range is defined by the LED forward voltage where output current is controlled at a nearly constant level. Figure 5 below shows this output characteristic and illustrates the three regions of operation: constant voltage, constant power and finally constant current.

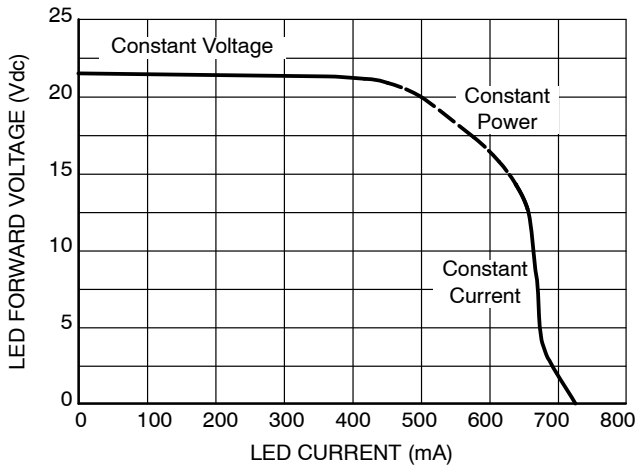

Figure 5. Output Current/Voltage Transfer Function, 115 Vac

LED output current as a function of input voltage is shown in Figure 6. Dimmer circuit was adjusted for maximum output. At this point, the controller is operating at peak power and some reduction in output current occurs as the efficiency is lower.

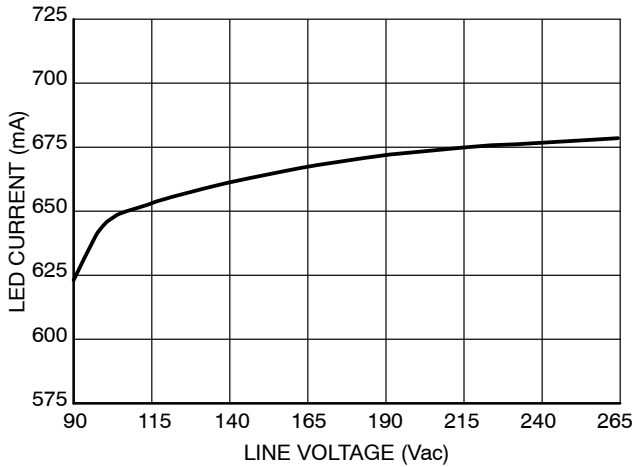

Figure 6. Current Versus Line Voltage, $V_f = 13.1$ V at 653 mA Current

Since many high brightness power LEDs are characterized at 350 mA, the dimming control was adjusted to provide 350 mA load current at 115 Vac input voltage. Figure 7 depicts the load current as the line voltage is varied from 90 Vac to 265 Vac.

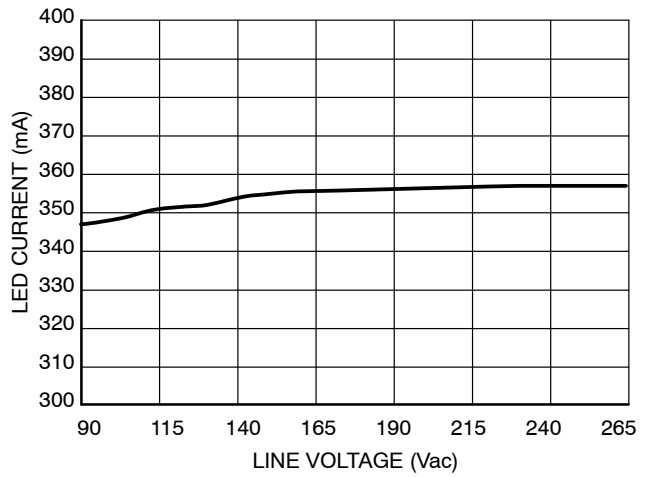

Figure 7. Current Regulation Across Line with Nominal Current set 350 mA, $V_f = 12.6$ Vdc

Power factor as a function of line voltage is shown in Figure 8 below. Note the power factor is greater than 0.8 for the input voltage range of 90 Vac to 135 Vac which well exceeds the ENERGY STAR requirements for residential luminaires.

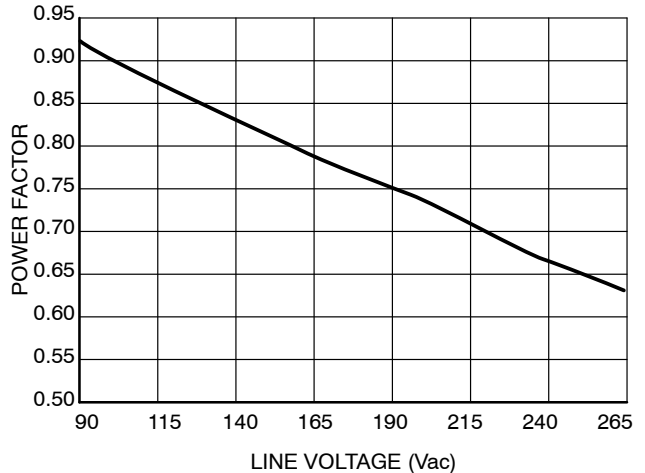

Figure 8. Power Factor versus Line Voltage

Lighting products in some regions are required to meet International Standard IEC 61000-3-2 Class C limits for harmonic content of input current. In this case, the applicable limits are for fixtures drawing less than 25 W. Table 1 shows the results for this LED driver.

Table 1.

Harmonic	115 Vac 60 Hz	230 Vac 50 Hz	Class C Limit
Third	52.4%	65.0%	86.0%
Fifth	23.0%	47.9%	61.0%

Conducted emissions data was collected using a load of 4 LEDs (1 Cree MC-E). Figure 9 below shows EN55022 Class B limit as the red line and a 6 dB margin as the dashed line below that. These results show significant margin on emissions.

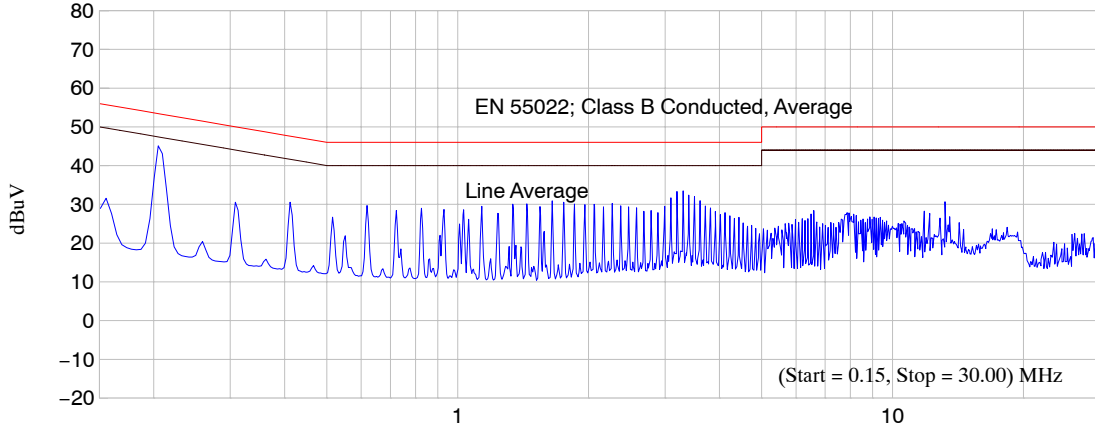

Figure 9. Conducted Emissions with Class B Limits, $V_{in} = 115$ Vac

The oscilloscope images below were collected using an isolated differential probe for primary connected components, a 10X probe for secondary components, and an

isolated current probe for current measurements. Figure 10 below is the NCP1014 drain voltage at 230 Vac input. Peak voltage is well below the maximum part rating of 700 V.

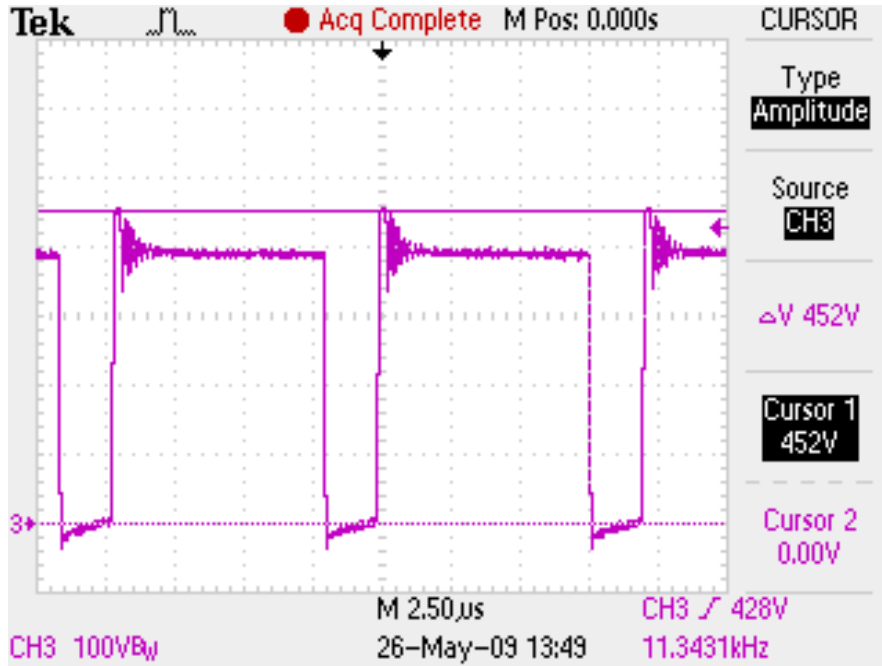

Figure 10. Drain Switching Voltage Waveform

TND371/D

The output current for 115 Vac and 230 Vac input is shown in Figures 11 and 12. This image shows the DC as well as AC components. Scale factor is 150 mA per division. Peak-to-peak ripple current is 144 mA which is

approximately $\pm 11\%$ at 115 Vac and drops at higher ac line. This is the main reason that the current slightly increases at high line as illustrated in Figure 6.

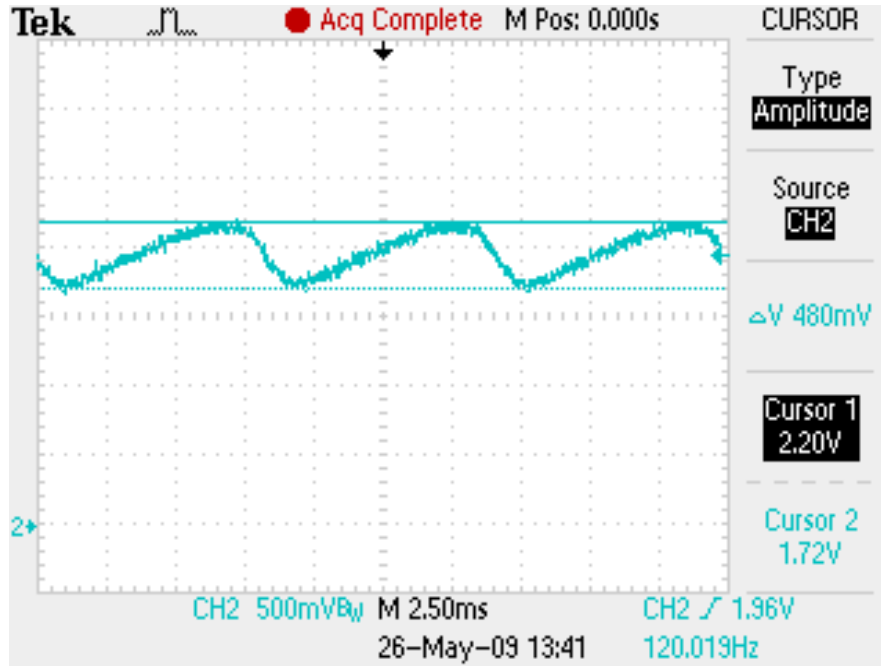

Figure 11. LED Ripple Current with 115 Vac Input

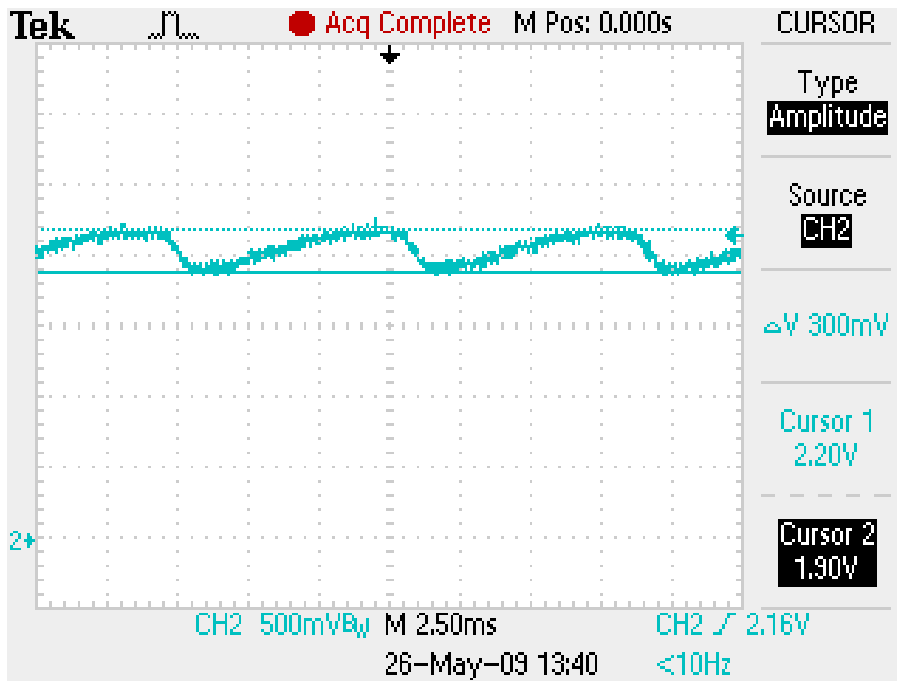

Figure 12. LED Ripple Current with 230 Vac Input

Figure 13 shows the start up current characteristic after application of 115 Vac input. Scale factor 150 mA per division. Output current rise time is ~810 ms.

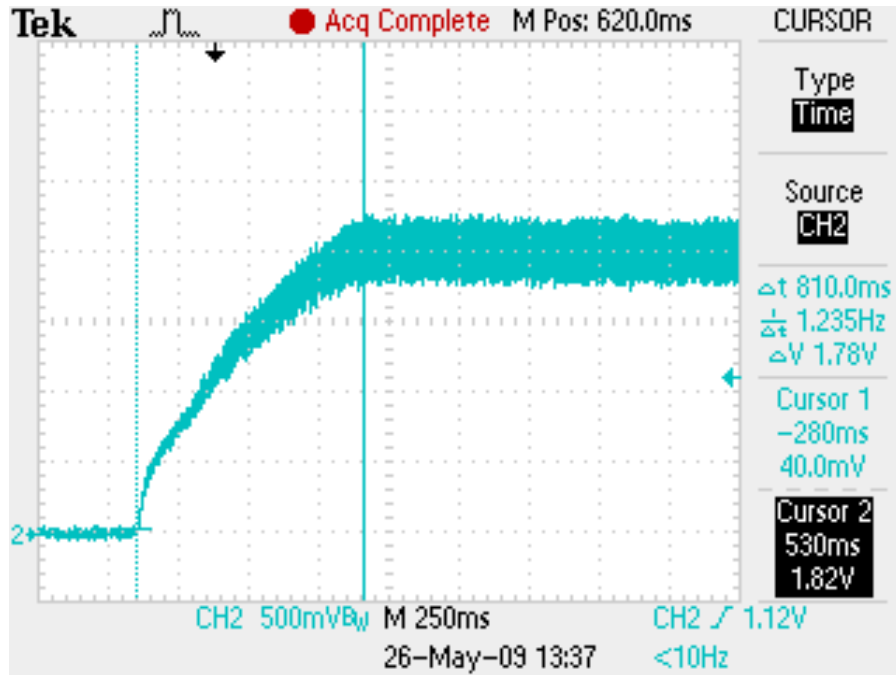

Figure 13. Startup at 115 Vac

Summary

Solid state lighting brings great promise in reducing global energy consumption while at the same time providing customers with a long lifetime product which can bring new lighting capabilities to the market. ENERGY STAR standardization for Solid State Luminaires also establishes

quantitative requirements which ensure that customers can be confident in their decisions. These new standards do add new requirements to LED drivers such as power factor correction that require novel solutions to meeting the requirements without adding increased complexity or cost.

Reference Materials:

- [1] ENERGY STAR[®] SSL Luminaire Specification, Version 1.1
http://www.ENERGYSTAR.gov/index.cfm?c=new_specs.ssl_luminaires
- [2] Cree XLAMP MC-E Specification
http://www.cree.com/products/xlamp_mce.asp
- [3] Fraen Reflector Optics for Cree MC-E
<http://www.fraensrl.com/prodinfo.html>
- [4] ON Semiconductor Design Note DN06051: Improving the Power Factor of Isolated Flyback Converters for Residential ENERGY STAR[®] LED Luminaire Power Supplies
http://www.onsemi.com/pub_link/Collateral/DN06051-D.PDF
- [5] LED Desk Lamp Conversion White Paper TND358:
http://www.onsemi.com/pub_link/Collateral/TND358-D.PDF

TND371/D

APPENDIX

Table 2. BILL OF MATERIALS

Value	Description	Part Reference	Manufacturer	Manufacturer Part Number
100 nF	CAP, 100 nF, 275 Vac	C1	Panasonic	ECQ-U2A104ML
220 nF	CAP, 220 nF, 275 Vac	C2	Panasonic	ECQ-U2A224ML
1.5 nF	CAP, 1.5 nF, 1 kV ceramic	C3	Murata	DEBB33A152KA2B
100 nF	CAP 100 nF 25 V ±10% 0603 SMD	C4	Panasonic	ECJ-1VF1H104Z
2.2 µF	CAP 2.2 µF 50 V 5 kHr 105°C 5x11 Radial	C5	Panasonic	EEU-EB1H2R2S
47 µF	CAP 47 µF 16 V 2 kHr 85°C 5x11	C6	Panasonic	ECA-1CM470
2.2 nF	CAP 2.2 nF "Y1" 250 Vac	C7	TDK Corp	CD12-E2GA222MYNS
1000 µF	CAP 1000 µF 25 V 2 kHr 85°C 10x20	C8 C9	Panasonic	ECA-1EM102
10 nF	CAP 10 nF 50 V ±10% 0603 SMD	C10	Panasonic	ECJ-1VB1H103K
MRA4007	Rectifier, 1000 V, 1 A, SMA	D1 D2 D3 D4	ON Semiconductor	MRA4007T3
MURA160	Rectifier, 600 V, 1 A, SMA	D5	ON Semiconductor	MURA160T3
MMBD914LT1	Rectifier, 100 V, 200 mA, SOT23	D6	ON Semiconductor	MMBD914LT1
MURS320T3	Rectifier, 200 V, 3 A, SMC	D7	ON Semiconductor	MURS320T3
BZX84C18LT1	Zener Diode, 18 V, 225 mW, SOT23	D8	ON Semiconductor	BZX84C18LT1G
MMBZ5231	Zener Diode, 5.1 V, 500 mW, SOT23	D9	ON Semiconductor	MMBZ5231BLT1G
TESTPOINT	Terminal Test point	E1 E2	Kobiconn	151-103-RC
Conn	Screw terminal	J1	Weidmuller	1716020000
Conn	Header, 1 row, 6 pin	J2	Tyco	535676-5
2.7 mH	IND, PWR, 2.7 mH	L1	Coilcraft	RFB0810-272
BC857	TRAN, PNP, 45 V, 100 MA, SOT23	Q1	ON Semiconductor	BC857BLT1G
BC846	TRAN, NPN, 65 V, 100 MA, SOT23	Q2	ON Semiconductor	BC846BLT1G
4R7	Fusible resistor, 4R7, 0.5 W	R1	Vishay	NFR25H0004708JR500
47k	RES, 47k, 1 W	R2	Vishay	PR01000104702JR500
1.5k	RES, 1.5k, 1/10 W, SMD 0603	R3	Panasonic	ERJ-3EKF1501V
200	RES, 200R, 1/10 W, SMD 0603	R4	Panasonic	ERJ-3EKF2000V
2.2k	RES, 2.2k, 1/10 W, SMD 0603	R5	Panasonic	ERJ-3EKF2201V
1R8	RES, 1R8, 1/4 W, SMD 1206	R6 R7	Vishay	CRCW12061R80FKEA
10R	RES, 10R, 1/4 W, SMD 1206	R8	Vishay	CRCW120610R0FKEA
Not Used		R9		
10k	RES, 10k, 1/4 W, SMD 1206	R10	Rohm	MCR18EZPJ103
100	RES, 100R, 1/10 W, SMD 0603	R11	Panasonic	ERJ-3EKF1000V
1k	RES, 1k, 1/10 W, SMD 0603	R12 R15	Panasonic	ERJ-3EKF1001V
10k	Potentiometer, 10k	R13	CTS	026TB32R103B1A1
820	RES, 820R, 1/10 W, SMD 0603	R14	Panasonic	ERJ-3EKF8200V
T1	Transformer	T1	ICE Components Würth-Midcom	TO09035 750811041
NCP1014	IC, CUR MODE CONT, 100 kHz, SOT-223	U1	ON Semiconductor	NCP1014ST100T3G
PS2561	OPTOCOUPLER, TRAN O/P, SMT4	U2	NEC ELECTRONICS	PS2561L-1-A

TND371/D

TRANSFORMER DESIGN SPECIFICATION

Project / Customer: ON Semiconductor – Aspen Greenpoint Desk Lamp (6 Feb 09)

Part Description: 8 watt flyback transformer, 100 kHz, 24 V / 360 mA

Schematic ID: T1

Inductance: 1.8 mH $\pm 5\%$

Bobbin Type: 8 pin horizontal mount for EF16

Core Type: EF 16 (E16/8/5); 3C90 or similar material

Core Gap: Gap for 1.8 mH

Table 3. WINDING DETAIL (in order of assembly)

Operation	Start	Finish	Details	Notes
Primary Bias	Pin 3	Pin 2	13T #32HN	Spread across bobbin in one layer
Insulate			1T Mylar tape	Lap ~0.1 inch
Primary winding	Pin 4	Pin 1	105T #32HN	Wind in 3 layers, 35 turns/layer
Insulate			1T Mylar tape	Lap ~0.1 inch
24 V Secondary	Fly1 1.5"	Fly2 1.5"	20T #26 TEX-E	Spread across bobbin in one layer Mark start lead with tape
Insulate			3T Mylar tape	
Assemble core				Gap for 1.8 mH
Vacuum varnish				Mark with part number

Hipot: 3 kV from Primary to Secondary for 1 Minute

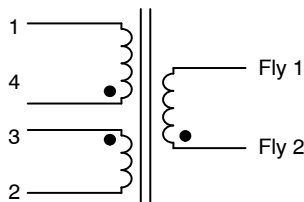

Figure 14. Schematic

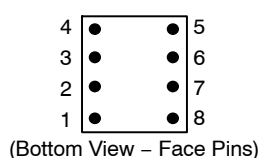
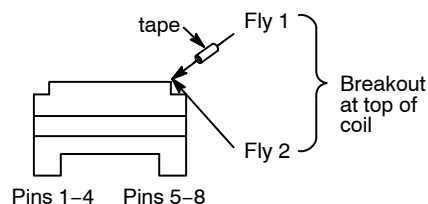

Figure 15. Lead Breakout / Pinout



SUPPORT INFORMATION

IEC 61000-3-2: International Standard for Electromagnetic Compatibility

DoE ENERGY STAR Standard for Solid State Lighting Luminaires (Version 1.1 – 12/19/08)

GreenPoint is a registered trademark of Semiconductor Components Industries, LLC (SCILLC).

ENERGY STAR and the ENERGY STAR mark are registered U.S. Marks; XLamp is a registered trademark of Cree, Inc.; Z-POWER is a registered trademark of Seoul Semiconductor Co., Ltd.; Golden Dragon is a trademark of Osram; Luxeon is a trademark of Lumileds Lighting.

ON Semiconductor and  are registered trademarks of Semiconductor Components Industries, LLC (SCILLC). SCILLC owns the rights to a number of patents, trademarks, copyrights, trade secrets, and other intellectual property. A listing of SCILLC's product/patent coverage may be accessed at www.onsemi.com/site/pdf/Patent-Marking.pdf. SCILLC reserves the right to make changes without further notice to any products herein. SCILLC makes no warranty, representation or guarantee regarding the suitability of its products for any particular purpose, nor does SCILLC assume any liability arising out of the application or use of any product or circuit, and specifically disclaims any and all liability, including without limitation special, consequential or incidental damages. "Typical" parameters which may be provided in SCILLC data sheets and/or specifications can and do vary in different applications and actual performance may vary over time. All operating parameters, including "Typicals" must be validated for each customer application by customer's technical experts. SCILLC does not convey any license under its patent rights nor the rights of others. SCILLC products are not designed, intended, or authorized for use as components in systems intended for surgical implant into the body, or other applications intended to support or sustain life, or for any other application in which the failure of the SCILLC product could create a situation where personal injury or death may occur. Should Buyer purchase or use SCILLC products for any such unintended or unauthorized application, Buyer shall indemnify and hold SCILLC and its officers, employees, subsidiaries, affiliates, and distributors harmless against all claims, costs, damages, and expenses, and reasonable attorney fees arising out of, directly or indirectly, any claim of personal injury or death associated with such unintended or unauthorized use, even if such claim alleges that SCILLC was negligent regarding the design or manufacture of the part. SCILLC is an Equal Opportunity/Affirmative Action Employer. This literature is subject to all applicable copyright laws and is not for resale in any manner.

PUBLICATION ORDERING INFORMATION

LITERATURE FULFILLMENT:

Literature Distribution Center for ON Semiconductor
P.O. Box 5163, Denver, Colorado 80217 USA
Phone: 303-675-2175 or 800-344-3860 Toll Free USA/Canada
Fax: 303-675-2176 or 800-344-3867 Toll Free USA/Canada
Email: orderlit@onsemi.com

N. American Technical Support: 800-282-9855 Toll Free
USA/Canada
Europe, Middle East and Africa Technical Support:
Phone: 421 33 790 2910
Japan Customer Focus Center
Phone: 81-3-5817-1050

ON Semiconductor Website: www.onsemi.com

Order Literature: <http://www.onsemi.com/orderlit>

For additional information, please contact your local Sales Representative