

ON Semiconductor

Is Now

onsemi™

To learn more about onsemi™, please visit our website at
www.onsemi.com

onsemi and **onsemi** and other names, marks, and brands are registered and/or common law trademarks of Semiconductor Components Industries, LLC dba "**onsemi**" or its affiliates and/or subsidiaries in the United States and/or other countries. **onsemi** owns the rights to a number of patents, trademarks, copyrights, trade secrets, and other intellectual property. A listing of **onsemi** product/patent coverage may be accessed at www.onsemi.com/site/pdf/Patent-Marking.pdf. **onsemi** reserves the right to make changes at any time to any products or information herein, without notice. The information herein is provided "as-is" and **onsemi** makes no warranty, representation or guarantee regarding the accuracy of the information, product features, availability, functionality, or suitability of its products for any particular purpose, nor does **onsemi** assume any liability arising out of the application or use of any product or circuit, and specifically disclaims any and all liability, including without limitation special, consequential or incidental damages. Buyer is responsible for its products and applications using **onsemi** products, including compliance with all laws, regulations and safety requirements or standards, regardless of any support or applications information provided by **onsemi**. "Typical" parameters which may be provided in **onsemi** data sheets and/or specifications can and do vary in different applications and actual performance may vary over time. All operating parameters, including "Typicals" must be validated for each customer application by customer's technical experts. **onsemi** does not convey any license under any of its intellectual property rights nor the rights of others. **onsemi** products are not designed, intended, or authorized for use as a critical component in life support systems or any FDA Class 3 medical devices or medical devices with a same or similar classification in a foreign jurisdiction or any devices intended for implantation in the human body. Should Buyer purchase or use **onsemi** products for any such unintended or unauthorized application, Buyer shall indemnify and hold **onsemi** and its officers, employees, subsidiaries, affiliates, and distributors harmless against all claims, costs, damages, and expenses, and reasonable attorney fees arising out of, directly or indirectly, any claim of personal injury or death associated with such unintended or unauthorized use, even if such claim alleges that **onsemi** was negligent regarding the design or manufacture of the part. **onsemi** is an Equal Opportunity/Affirmative Action Employer. This literature is subject to all applicable copyright laws and is not for resale in any manner. Other names and brands may be claimed as the property of others.



ON Semiconductor

DN05091/D

Design Note – DN05091/D

3 LED Low Voltage Parallel-to-Series Lighting Circuit

Application	Input Voltage	Topology	Max DC Voltage
Low Voltage Lighting	7 to 16 V	Low Cost Parallel-to-Series	36 V

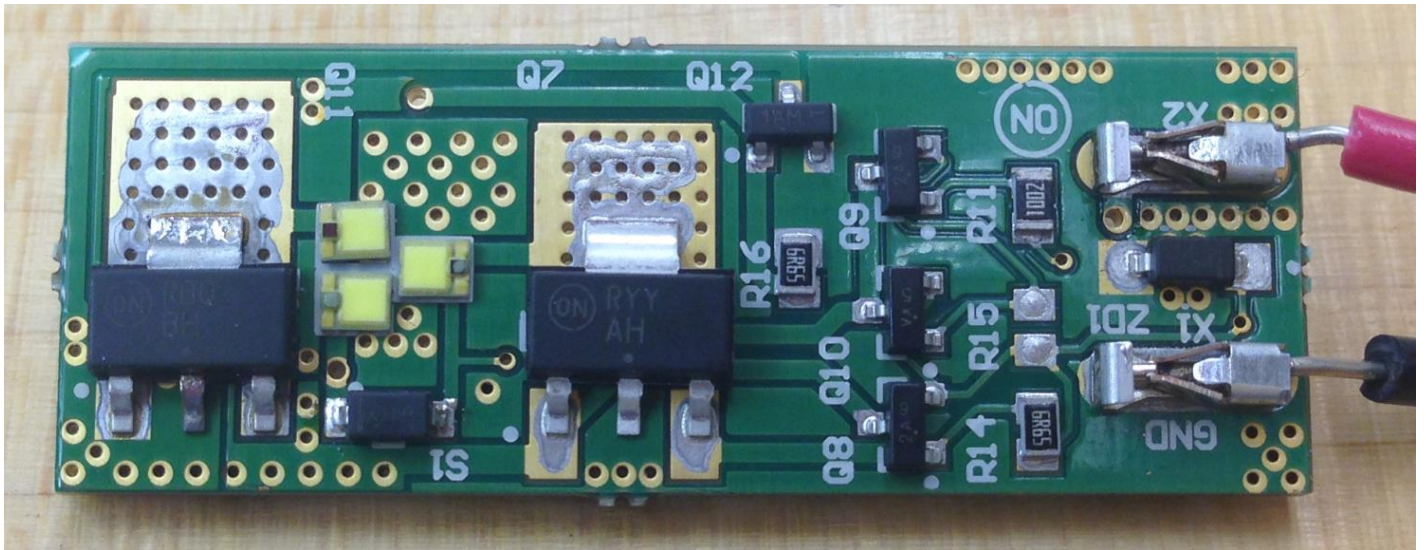

Figure 1 – Top of evaluation board

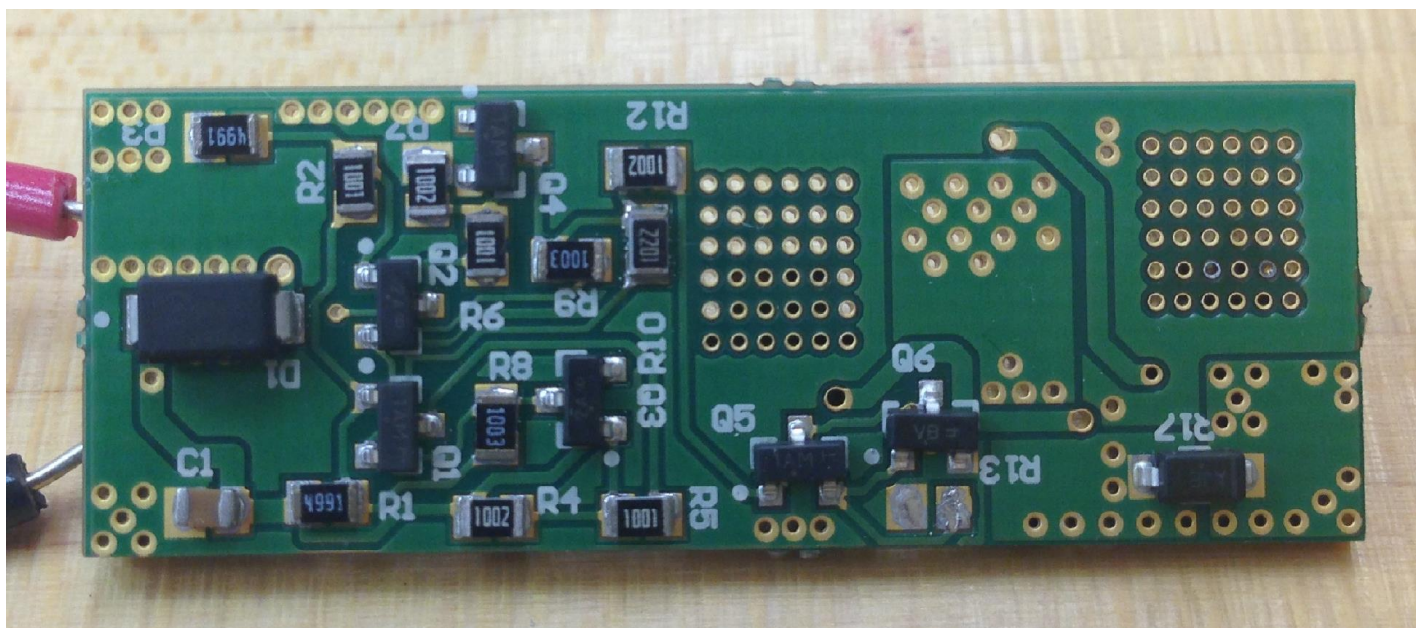

Figure 2 – Bottom of evaluation board

Key Features

- Low cost, general purpose LED circuit for low voltage applications
- Uses three LEDs, each with a forward voltage of about 3 volts
- If the battery voltage is above 4 V, there is light output
- Above 7 V battery voltage light output is constant and full brightness
- All LEDs are equally bright at all times, so LEDs can be placed far apart from each other
- Board-to-board LED current regulation is less than +/- 5%

Schematic

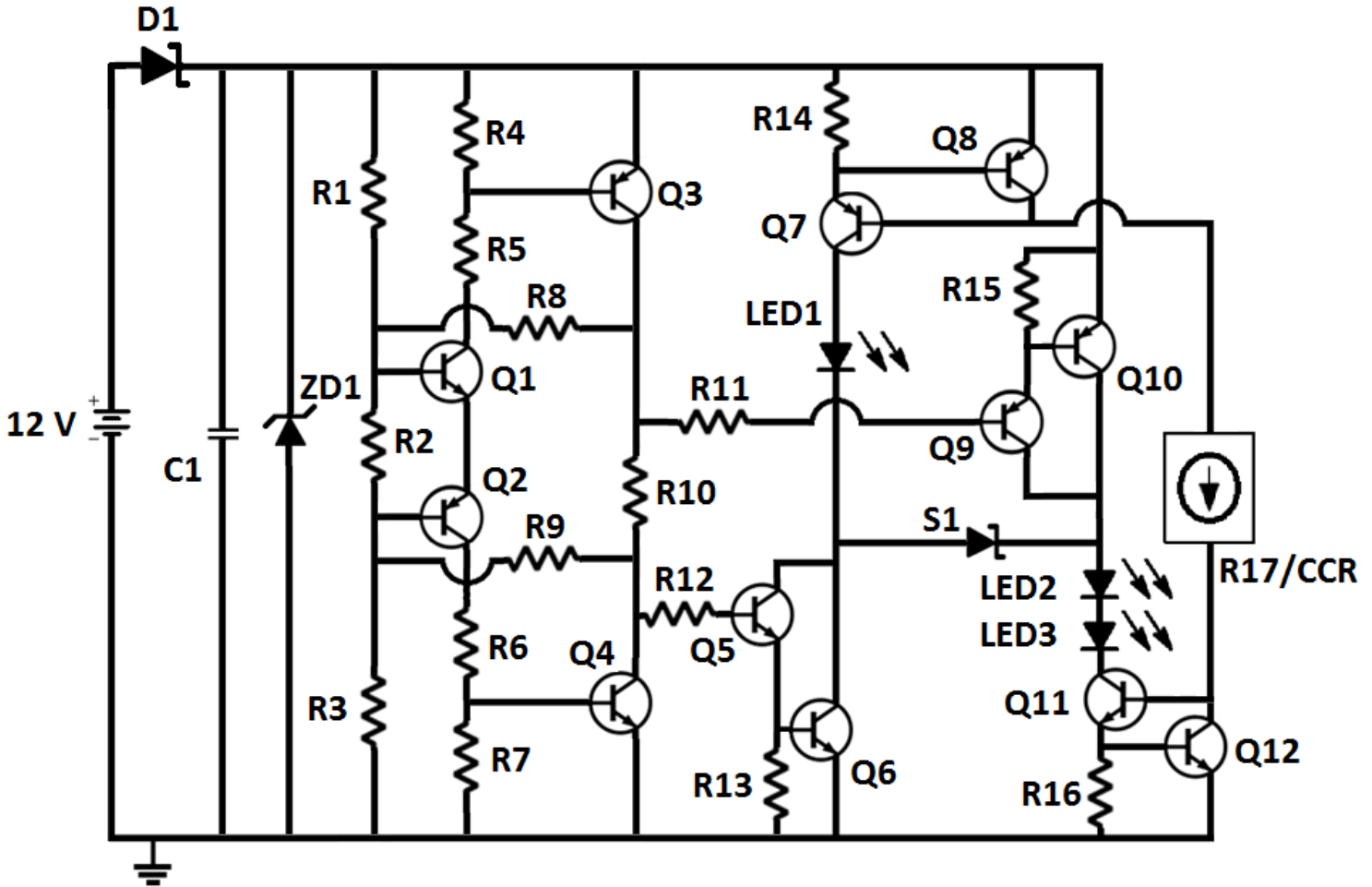

Figure 3 – Circuit Schematic.

The parallel-to-series concept

Parallel-to-series means that at low input voltages, the two LED strings are configured in parallel, and above a certain threshold voltage the two LED strings are in series. This allows excellent light output at low voltage and good efficiency at higher voltage.

The circuit shown in Figures 1-3 is a variation of the parallel-to-series LED lighting circuit that is shown in several other design notes. See for example DN05088, which is about a 60 W, 120 Vac input light bulb circuit. Typically the parallel-to-series is for 120 V AC input applications that require low time harmonic distortion and compatibility with TRIAC dimmers.

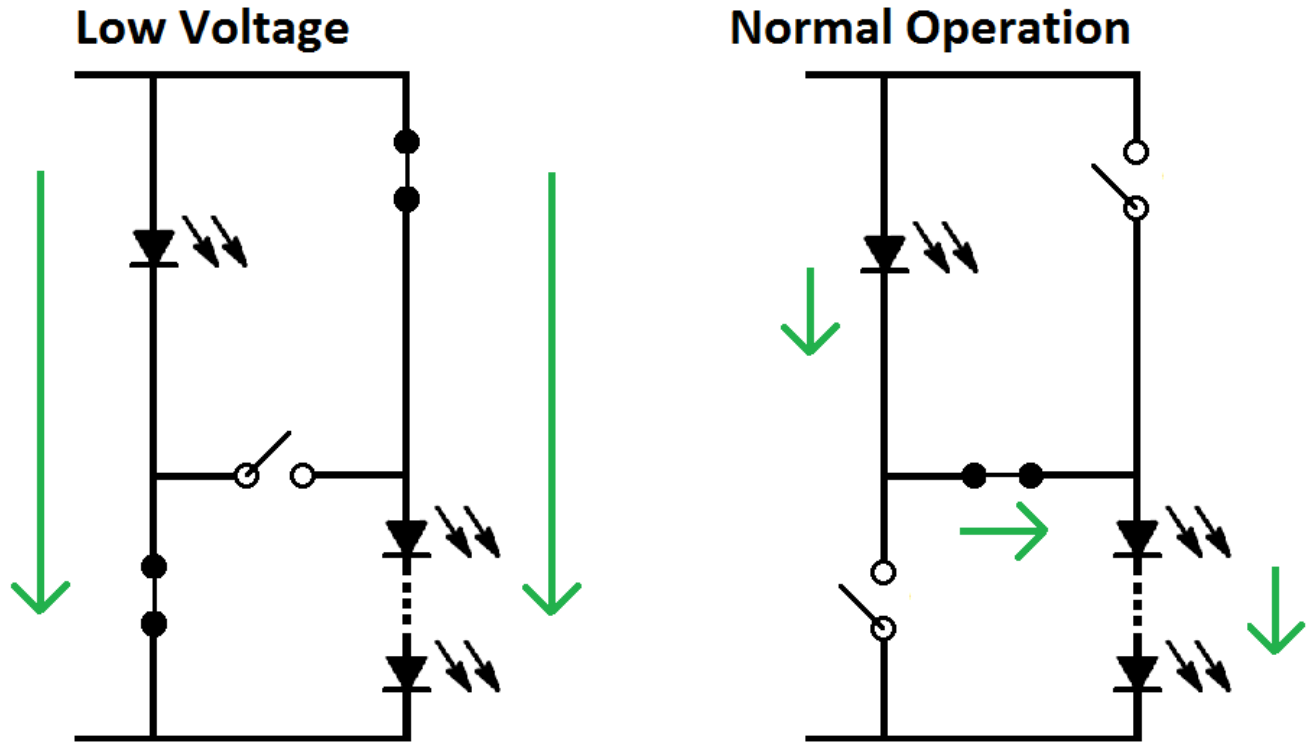
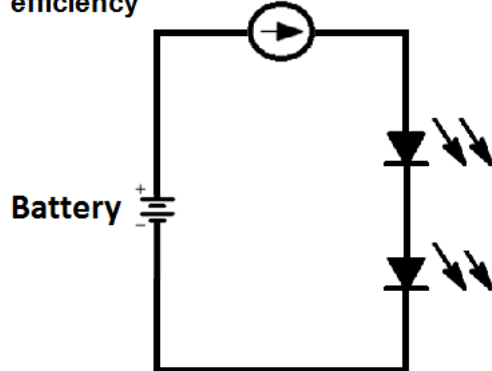

Figure 4 – The LED configuration is dynamically adjusted by the control circuitry. When the input voltage is relatively low, the LEDs are configured in parallel. At higher voltage, the LEDs run in series.

Consider a more rudimentary circuit with just a single string of LEDs, such as those shown in Figure 5. Using two LEDs in series would yield a 6.0 V LED voltage, while three LEDs would give a 9.0 V LED voltage. The problem with two LEDs is that it is inefficient at the normal battery voltage. Three LEDs would be more efficient than two LEDs. However, if the battery voltage dips low (such as below 10.0 V), light output may be severely diminished or gone altogether.

2 LEDs: Good light output range, bad efficiency



3 LEDs: Bad light output range, good efficiency

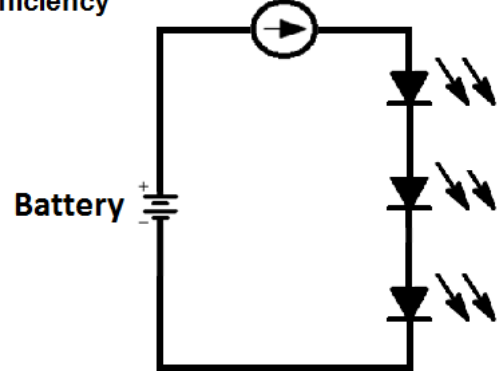

Figure 5 – Normally low voltage LED circuits are built with two or three LEDs in series driven with a linear (non-switching) current regulator. These two lighting circuits show the basic problem with a simple series string of LEDs. Actually some applications also use just a single LED, which has a cost advantage but is pretty inefficient.

The 3 LED parallel-to-series topology shown in this design note combines the advantages of both 2 and 3 LED string configurations, and eliminates the disadvantages. Furthermore, it allows the added benefit of turn on of a single LED at only 4 V. As Figure 6 shows, the LEDs will be at full brightness when the battery voltage is above 7 V.

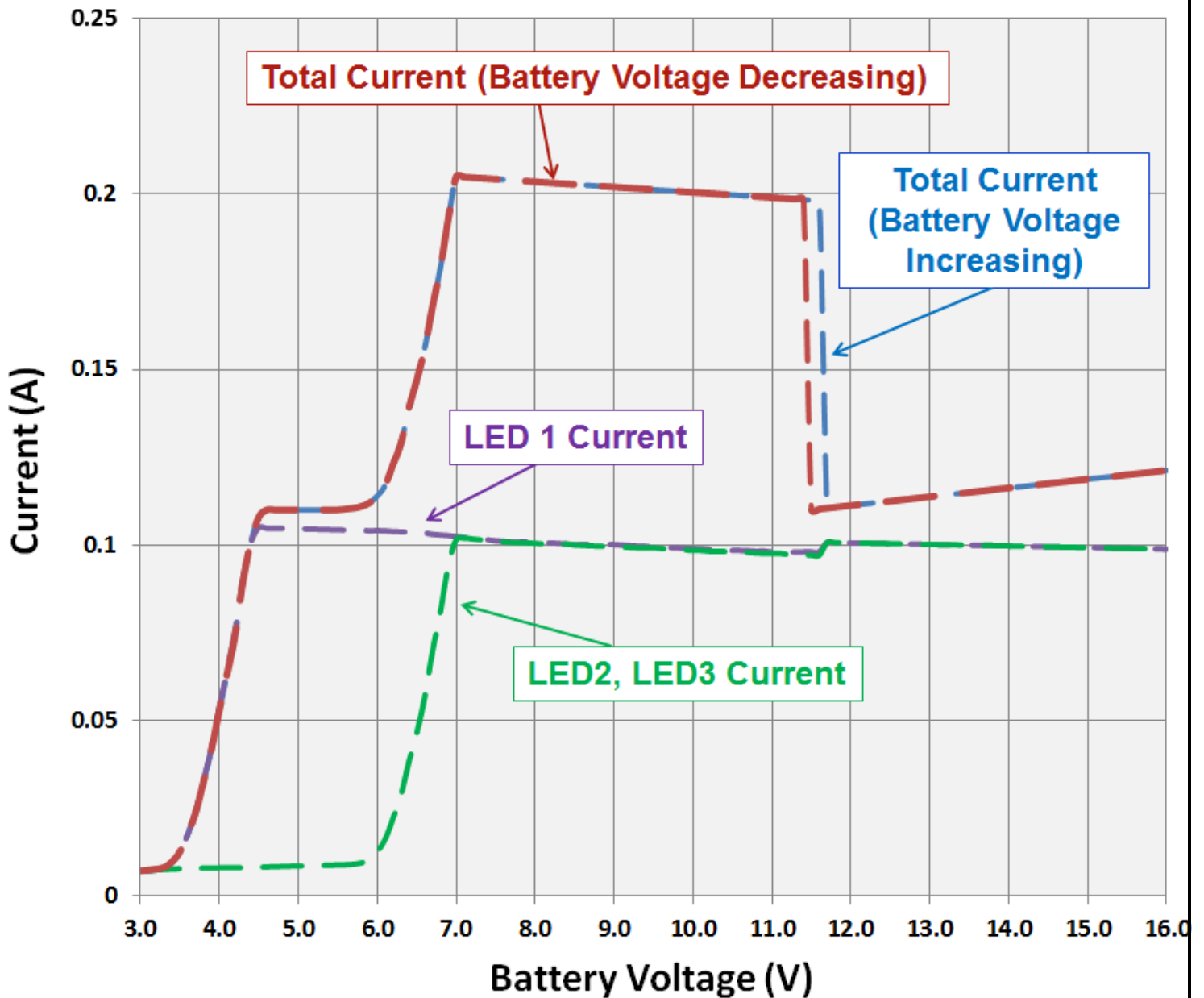

Figure 6 – Light output begins just below 4 V. At 5 V, one LED is at full brightness. At 7 V and up all LEDs are fully on and equally bright. There is slightly less LED current at higher battery voltage because the I-V characteristic is taking board heating into effect; that is the negative temperature coefficient of the current regulators in action. Note also the hysteresis of the total battery current around the switching point.

Basic Circuit Design and Operation

This circuit is designed to handle most protection requirements and accomplish the task of alternating between parallel and series LED configurations at the lowest possible cost.

The base-emitter voltage drops of Q1 and Q2 determine the switching point. To change the threshold, adjust R2 in small increments. Higher values of R2 will yield a lower switching point. While the circuit is operating in parallel, Q1-Q4 are off, all other transistors are on, and S1 is blocking. In series, Q5, Q6, Q9, and Q10 are off, all other transistors are on, and S1 is conducting.

Adjusting current levels

LED current is adjusted with R14 and R16. Ohm's law with a voltage of 0.66 V is used to set the current. The 0.66 V level comes from the base-emitter voltage of Q8 and Q12.

If the current is to be dramatically increased, consider using larger, higher gain transistors for Q7 and Q11. Additional LEDs may be added by simply placing more in parallel with LED1 and LED2-LED3.

Flicker Prevention

One important consideration of this class of circuit is the absolute prevention of flicker near the switching point. Brief undulations in LED current could be visible and unpleasant. Even changes in the microsecond range can be visible sometimes. To make sure flickering is impossible a couple special techniques were used in the design of the circuit.

One of these techniques involves the dual current regulator structures above and below the LED strings. These structures are Q7, Q8, and R14 on the top and Q11, Q12, and R16 on the bottom. Whenever the circuit is to operate in parallel, the total current drawn is twice that when it is operating in series. This is so because both current regulators are operating apart from each other in separate strings. In series, the current regulator structures are in series with each other. This ensures that the LED current and brightness of the circuit are constant, regardless of the battery voltage. The way this circuit is designed precludes any need to modify the regulation current on the fly. There is no need to send a signal to suddenly double or halve the current. The advantage is that there are no additional propagation delays or signal paths which might inadvertently cause flickering.

The other anti-flicker structure in this circuit is the threshold detector. Very minimalistic control circuits as shown in other design notes (see DN05084 or DN05084) would have difficulty preventing flicker at the switching point. Q6 and Q10 are the main conducting switches for parallel operation. In order to ensure they are both on or both off at exactly the same time, a universal base current path through R10 is used.

Furthermore, the base-emitter voltage of Q1 and Q2 has a temperature coefficient in the same direction as those of the LEDs, which means as the LED voltage drifts, the switching point will follow it. This is based on the inherent drop in base-emitter voltage over temperature of a BJT.

Protection

This circuit is built to withstand harsh voltages in a system. The most basic of these is the reverse protection mechanism. A Schottky diode is employed near the input so that if the input voltage is connected backwards no current will flow. To block higher levels of voltage or to minimize the voltage drop, consider using a MOSFET instead.

For voltage transients in the forward direction, it employs circuitry capable of withstanding high levels of DC and a Zener diode to provide a shunt path for transients. It will withstand Pulse 2 A and Pulse 5B of the ISO7637 standard. For example, for the Pulse 2A test, which simulates local inductive spikes in the system, it was subjected to spikes of 50 volts on top of 14 volts DC. Multiple strikes do not harm the circuit. See Figure 7 for the waveforms during the test. This circuit also can withstand at least 36 volts DC steady-state. It is not set up to withstand a 110 V, 400 ms pulse such as Pulse 5A, because it is expected that most applications will have that surge suppressed by another device.

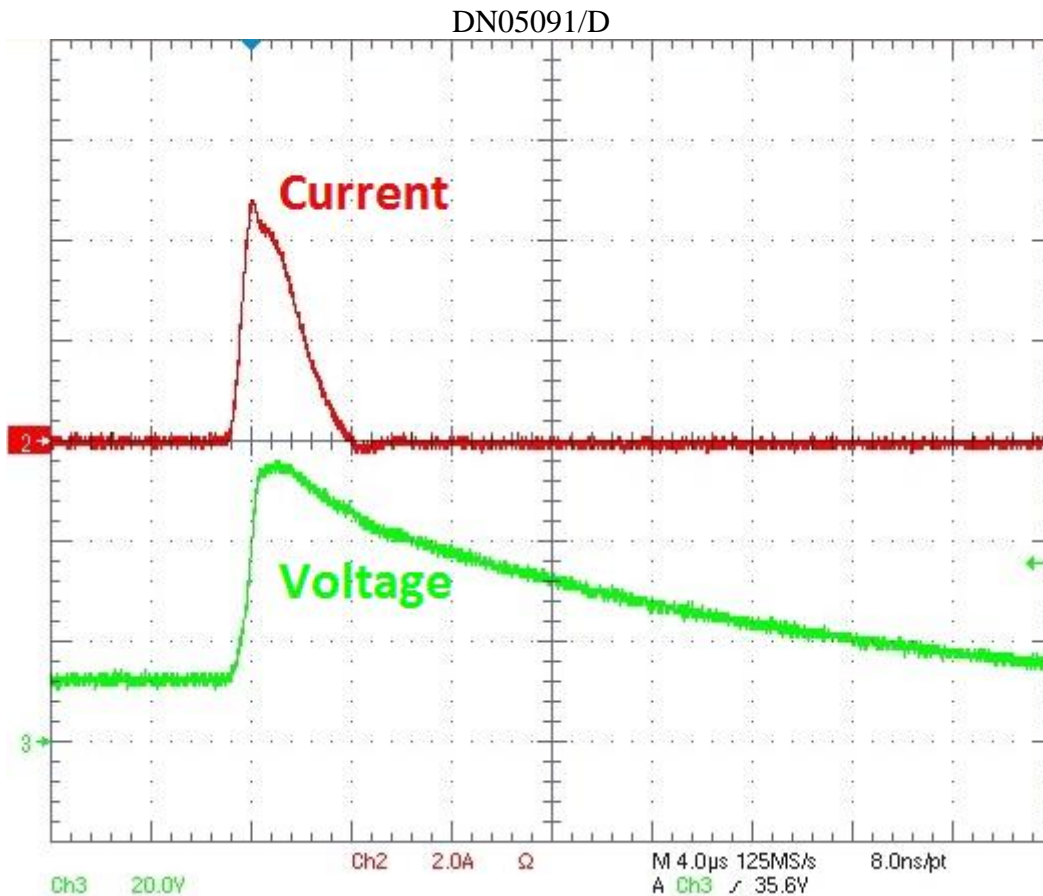

Figure 7 – The circuit was subjected to repeated ISO7637 Pulse 2A strikes. The test conditions were a 2 ohm source resistor, 14 volts DC input with a 50 volt pulse on top of it. The circuit was fully functional before and after testing.

Discussion of Individual Components

In order to better understand the circuit, some considerations regarding the individual components will be given from left to right referring to the schematic shown in Figure 3.

- D1 is a Schottky diode that protects against reverse battery voltages. Important parameters for this device are obviously its reverse breakdown voltage, but also its continuous DC current rating and its low forward voltage drop. If the forward voltage drop is a problem, or if protection from reverse spikes greater than 100 V is required, consider using a MOSFET instead.
- C1 is a small surface mount ceramic capacitor. Higher values of capacitance are better (as high as 10 μ F would be reasonable), as it serves to filter out inductive voltage spikes.
- ZD1 is a transient voltage suppression device. The breakdown is at about 43 V. Higher Zener voltages would not protect as well and lower voltages would potentially interfere with other suppression devices in the system.
- R1 is fundamental to the parallel-to-series switching threshold. It should be set to the same value as R3. Too low of a value will be detrimental to efficiency but too high of a value might interfere with how the circuit switches from parallel to series.
- R2 works with R1 and R3 to set the switching point.
- R3 has the same considerations as R1, as it is just its symmetrical counterpart.
- R4 provides a leakage path around Q3 to prevent accidental turn-on of Q3 in adverse conditions. It should not be too small of a value because it could limit Q3's base current or cause it not to have enough of a drop from emitter-to-base to be on.

- R5 and R6 limit base current for Q3 and Q4. These are set low enough to provide sufficient base current but not so low that they hurt overall circuit efficiency. Also they work as part of a ratio with R4 and R7 to make Q3 and Q4 operate. Ensure R4 and R7 are much larger than R5 and R6.
- Q1 and Q2 are being used for their base-emitter voltages. These are the lowest-cost transistors possible because they are not tasked with conducting much current.
- R7 is R4's low-side counterpart.
- R8 and R9 are resistors that set up the hysteresis of the switching point. They are chosen to be quite a bit larger than R1 and R3 in order to minimize the latching effect.
- Q3 turns off Q9 and Q10. The lowest cost transistor is used because it is not conducting much current.
- R10 must not be too low of a value will yield poor efficiency, but too high of a value will preclude correct operation of Q6 and Q10. In higher power designs, consider using multiple resistors in series to spread the power dissipation and heat of R10.
- Q4 is the low-side counterpart of Q3.
- Q5 is part of a Darlington pair. It is low cost because it just provides base current to Q6.
- Q6 may be a small transistor because it does not need to have a lot of power dissipation (as in a current regulator). However, it does need to conduct a lot of current so it is a low VCE(Sat) device.
- R13 should not be populated. In some cases populating this resistor will cause flickering.
- R14 sets the regulation current for Q7 and Q8. Use Ohm's law with 0.66 V to set the LED current.
- Q7 must be a large transistor because it is the main pass transistor for the top current regulator. SOT-223 or DPAK packages are required to help spread out the heat. Also it must be capable of conducting a lot of current.
- LED1 must be of sufficiently low voltage such that it does not create too large of a series string with LED2 and LED3. Otherwise it may be a single LED or a parallel array of LEDs.
- S1 is a Schottky diode that is only on in parallel mode. It must have a low forward voltage drop, but the maximum reverse voltage it will see is less than 20 V, so its reverse breakdown rating is not critical.
- Q8 is a small, low-cost transistor because it only provides feedback to Q7 to regulate the current.
- R15 should not be populated.
- Q9 is the counterpart to Q5.
- Q10 is the counterpart to Q6.
- LED2-LED3 is the counterpart to LED1.
- Q11 is the counterpart to Q7.
- Q12 is the counterpart to Q11.
- R16 is the counterpart to R14.
- R17/CCR provides base current to the current regulators. For very low power applications (sub 50 mA LED current), a resistor will likely be sufficient, but for other levels use a CCR (two-terminal constant current regulator). Q7 and Q11 need a lot of base current at low battery voltage but not so much at high voltage that overall system efficiency is hurt, so a constant current through the base is very nice to have.

Bill of Materials

Designator	Quantity	Description	Value	Tolerance	Footprint	Manufacturer	Manufacturer Part Number	Substitution Allowed
C1	1	Capacitor SMD	1 uF, 50 V	20%	0805	Any	Any	Yes
Connectors	2	SMD	N/A	N/A	SMD	AVX	AVX 709296001002006	No
D1	1	Schottky Diode SMD	100 V	NA	SMA	ON Semiconductor	MBRA1H100T3G	No
LED1-3	3	SMD LED	3 V	N/A	SMD	Lumileds	LFXH-C2B-0200	No
Q1, Q4, Q5, Q12	4	NPN Bipolar Transistor SMD	N/A	N/A	SOT-23	ON Semiconductor	MMBT3904LT1G	No
Q2, Q3, Q8, Q9	4	PNP Bipolar Transistor SMD	N/A	N/A	SOT-23	ON Semiconductor	MMBT3906LT1G	No
Q6	1	NPN Bipolar Transistor SMD	N/A	N/A	SOT-23	ON Semiconductor	NSS40201L	No
Q7	1	PNP Bipolar Transistor SMD	N/A	N/A	SOT-223	ON Semiconductor	BCP53	No
Q10	1	PNP Bipolar Transistor SMD	N/A	N/A	SOT-23	ON Semiconductor	NSS40200L	No
Q11	1	NPN Bipolar Transistor SMD	N/A	N/A	SOT-223	ON Semiconductor	BCP56	No
R1, R3	2	Resistor SMD	4.99k, 1/8th W	5%	0805	Any	Any	Yes
R2, R5, R6	3	Resistor SMD	1k, 1/8th W	5%	0805	Any	Any	Yes
R4, R7, R11, R12	4	Resistor SMD	10k, 1/8th W	5%	0805	Any	Any	Yes
R8, R9	2	Resistor SMD	100k, 1/8th W	5%	0805	Any	Any	Yes
R10	1	Resistor SMD	2.2k, 1/8th W	5%	0805	Any	Any	Yes
R13, R15	2	Resistor SMD	DNP	5%	0805	Any	Any	Yes
R14, R16	2	Resistor SMD	6.65, 1/8th W	5%	0805	Any	Any	Yes
R17	1	CCR	10 mA, 50 V	-	SOD-123	ON Semiconductor	NSI50010Y	No
S1	1	Schottky Diode SMD	30 V	NA	SOD-123	ON Semiconductor	BAT54	No
ZD1	1	Zener	43 V		SOD-123	ON Semiconductor	MMSZ5260B	No

© 2016 ON Semiconductor.

Disclaimer: ON Semiconductor is providing this design note “AS IS” and does not assume any liability arising from its use; nor does ON Semiconductor convey any license to its or any third party’s intellectual property rights. This document is provided only to assist customers in evaluation of the referenced circuit implementation and the recipient assumes all liability and risk associated with its use, including, but not limited to, compliance with all regulatory standards. ON Semiconductor may change any of its products at any time, without notice.

Design note created by Andrew Niles with contributions from Andrew Stemple and Kevin O’Connor