

ON Semiconductor

Is Now

onsemi™

To learn more about onsemi™, please visit our website at
www.onsemi.com

onsemi and **onsemi** and other names, marks, and brands are registered and/or common law trademarks of Semiconductor Components Industries, LLC dba "**onsemi**" or its affiliates and/or subsidiaries in the United States and/or other countries. **onsemi** owns the rights to a number of patents, trademarks, copyrights, trade secrets, and other intellectual property. A listing of **onsemi** product/patent coverage may be accessed at www.onsemi.com/site/pdf/Patent-Marking.pdf. **onsemi** reserves the right to make changes at any time to any products or information herein, without notice. The information herein is provided "as-is" and **onsemi** makes no warranty, representation or guarantee regarding the accuracy of the information, product features, availability, functionality, or suitability of its products for any particular purpose, nor does **onsemi** assume any liability arising out of the application or use of any product or circuit, and specifically disclaims any and all liability, including without limitation special, consequential or incidental damages. Buyer is responsible for its products and applications using **onsemi** products, including compliance with all laws, regulations and safety requirements or standards, regardless of any support or applications information provided by **onsemi**. "Typical" parameters which may be provided in **onsemi** data sheets and/or specifications can and do vary in different applications and actual performance may vary over time. All operating parameters, including "Typicals" must be validated for each customer application by customer's technical experts. **onsemi** does not convey any license under any of its intellectual property rights nor the rights of others. **onsemi** products are not designed, intended, or authorized for use as a critical component in life support systems or any FDA Class 3 medical devices or medical devices with a same or similar classification in a foreign jurisdiction or any devices intended for implantation in the human body. Should Buyer purchase or use **onsemi** products for any such unintended or unauthorized application, Buyer shall indemnify and hold **onsemi** and its officers, employees, subsidiaries, affiliates, and distributors harmless against all claims, costs, damages, and expenses, and reasonable attorney fees arising out of, directly or indirectly, any claim of personal injury or death associated with such unintended or unauthorized use, even if such claim alleges that **onsemi** was negligent regarding the design or manufacture of the part. **onsemi** is an Equal Opportunity/Affirmative Action Employer. This literature is subject to all applicable copyright laws and is not for resale in any manner. Other names and brands may be claimed as the property of others.



ON Semiconductor

Improving the Power Factor of Isolated Flyback Converters for Residential ENERGY STAR® LED Luminaire Power Supplies

Device	Application	Input Voltage	Output Power	Topology	I/O Isolation
NCP1014	LED Driver	90 to 265 Vac	Up to 8 Watts	Flyback	Yes

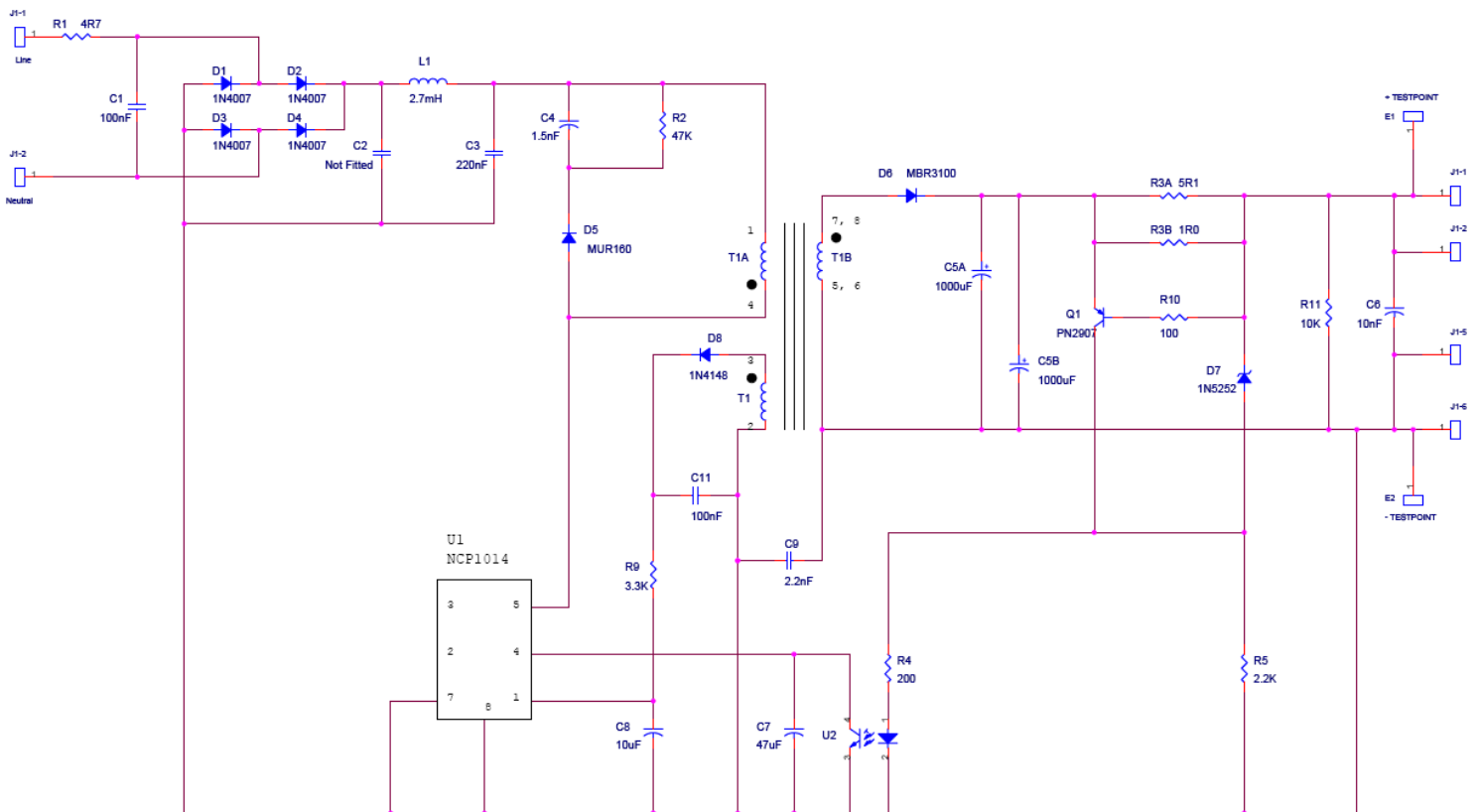

Figure 1: NCP1014 LED Driver with improved power factor

Overview

The U.S. Department of Energy (DOE) [ENERGY STAR® Standard for Solid State Lighting Luminaires](#) (Version 1.1 dated December 19, 2008) includes requirements for a minimum power factor of 0.7 for a variety of residential lighting products. Some of the typical products in this category include portable desk

lamps, under-cabinet lights, and outdoor porch lights.

One of the most common power supply topologies for these types of applications is an isolated flyback topology. Unfortunately standard design techniques used to design these supplies typically result in power factors in the range of 0.5-0.6. This design note describes why the

power factor is low and discusses techniques to improve the power factor and illustrates how an existing design was modified to substantially improve the power factor and easily comply with the residential power factor requirements.

Background

This Design Note outlines modifications to the [NCP1014LEDR2GEVD](#) 8 W Universal Input Isolated Constant Current evaluation board. The NCP1014LED evaluation board has been optimized to drive 1-8 high power high current LEDs such as the Cree XLAMP™ XR-E/XP-E, Luxeon™ Rebel, Seoul Semiconductor Z-Power, or OSRAM Golden Dragon™. The design is built around the NCP1014, a compact fixed frequency PWM converter that integrates a high voltage power switch with internal current limiting.

Since the device is limited to a maximum power of approximately 8 W with a universal AC input, the number of LEDs that can be driven is a function of the drive current. Specifically for this design note, the load will be one Cree XLAMP MC-E driven at 550 mA. The MC-E is comprised of 4 LEDs mounted on a single substrate and the maximum rated current is 700 mA.

A typical off-line flyback power converter, such as the one in the evaluation board mentioned above, utilizes a full wave bridge rectifier and substantial bulk capacitance preceding the switching regulator. This configuration is chosen because twice every line cycle the line power reduces and ultimately reaches zero before rising to the next peak. The bulk capacitor fills in providing a constant input to the switching regulator maintaining power flow to the load independent of line variations.

This configuration comes at the expense of poor utilization or power factor of the input line waveform. Line current is drawn in high amplitude narrow pulses near the peaks of the voltage waveform introducing disruptive high frequency harmonics. Passive solutions are well documented but typically introduce many

additional components. One approach is the valley-fill type rectifier where a collection of electrolytic capacitors and diodes increases the line frequency conduction angle resulting in improved power factor. In effect, this process charges the series-connected capacitors from the high line voltage at low current and discharges them to the switching regulator at a lower voltage with higher current. A typical application uses two capacitors and three diodes (figure 2) or, for enhanced power factor performance, three capacitors and six diodes (figure 3).

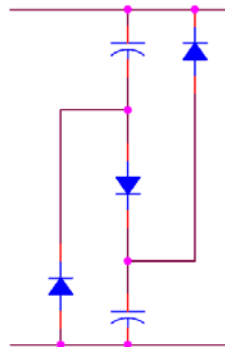

Figure 2:
Two Capacitor Valley Fill

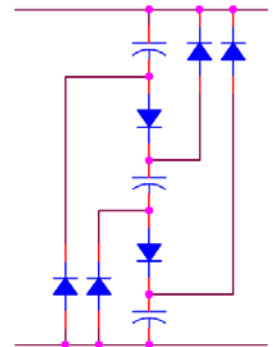

Figure 3:
Three-Capacitor Valley Fill

While the valley-fill rectifier improves the utilization of the line current, it does not provide a constant input to the switching regulator. Power delivered to the load will have significant ripple at twice the line power frequency. Note that the four diodes rectifying the line power are still needed bringing the total number of diodes for this solution to 7 or 10. These diodes and multiple electrolytic capacitors add cost, degrade reliability and consume considerable circuit board area.

Another solution is an active power factor boost stage placed on the input of the switching regulator. This approach provides superior power factor with typical performance > 0.98, but it comes with increased parts count, reduced efficiency and increased complexity. This approach is most suitable at power levels well above the modest power level of these applications.

Approach

High power factor requires generally sinusoidal line current and minimizing the phase displacement between the line current and voltage.

The first step in this modification is reducing the capacitance before the switching device to allow a more sinusoidal input current. Electrolytic capacitor C2 is eliminated and C3 is reduced from 4.7 μF to 220 nF allowing the rectified voltage to follow the line voltage thus eliminating the peak charging characteristic resulting in a more desirable sinusoidal current flow.

The input voltage to the power converter now follows a rectified sine shape at twice the line frequency. If the input current is kept to the same shape, the power factor will be high. The energy delivered to the load will follow the product of voltage and current which is a sine-squared shape. As a result of this sine-squared energy transfer, the load will experience ripple at twice the line frequency.

As mentioned above, the input current must be kept to a nearly sinusoidal shape to achieve the highest power factor. The key to this is not allowing the control loop to correct for load ripple by holding the feedback input at a constant level.

One option is to significantly increase the output capacitance to reduce the amount of 120 Hz ripple which some applications may require. The easier and less costly way of doing that is to filter the feedback signal going back to the controller establishing a constant level. This level fixes the maximum current in the power switch. The current in the power switch is determined by the applied instantaneous input voltage divided by the transformer primary inductance times the length of time the power switch is conducting. Since the NCP1014 operates at a fixed frequency, the current cannot rise beyond a

certain point as determined by the input voltage and primary inductance before the end of the switching period or conduction time. As a result of the conduction time limitation, the input current will follow the shape of the input voltage providing improved power factor.

The fixed feedback level represents the maximum current in the power switch corresponding to the peak of the input voltage wave shape. The peak level is established at the point where the proper average energy is transferred to the LED over a complete cycle of line input.

Achieving this fixed feedback level requires nothing more than increasing the feedback capacitor C7 to the point that any correction made by optocoupler U2 is averaged below the line frequency allowing only compensation for LED voltage and RMS line voltage variations.

The single stage converter is not without caveats. As mentioned above, energy is transferred to the secondary in a sine-squared shape. The flyback transformer must couple this energy and therefore be capable of processing peak power about 1.4 times the average delivered power.

The peak ripple needs to be controlled to keep it below the maximum rating of the selected LED. Increasing the filter capacitor integrates the pulsating current delivered to the secondary and provides more constant level to the LED load. The capacitance can be tailored to limit ripple current as required. See the oscilloscope image of LED current next page (figure 4).

Line input filter capacitor C1 and inductor L1 were optimized to comply with conducted emissions requirements. Resistor R4 and R5 were changed to improve effectiveness of regulation transistor Q1. D6 was changed to reduce rectifier losses. Current sense resistors R3A and R3B were changed to increase output power.

Typical performance of the LED driver demonstration board before and after

Before	
<i>Input:</i> 115 Vac, 94.9 mA, 6.52 W, 0.597 power factor	<i>Output:</i> 361 mA, 12.66 Vdc
After Modifications	
<i>Input:</i> 115 Vac, 115 mA, 11.8 W, 0.891 power factor	<i>Output:</i> 545 mA, 14.75 Vdc

(Note substantially more power is delivered with only a small increase in input current due to improved power factor.)

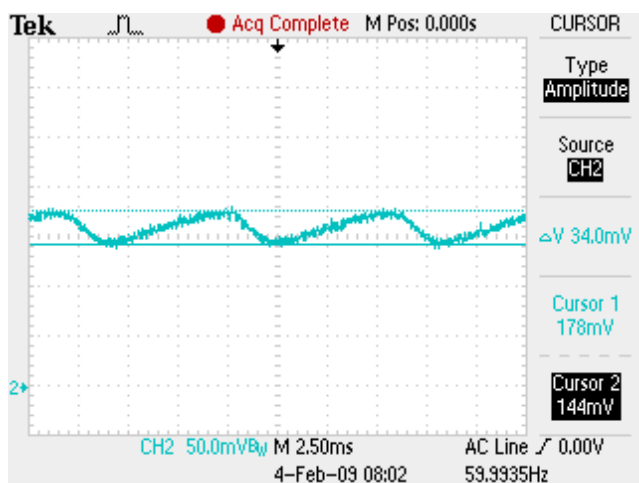

**Figure 4: LED Current (3.33 A/volt)
Ripple = 113 mA (p-p)**

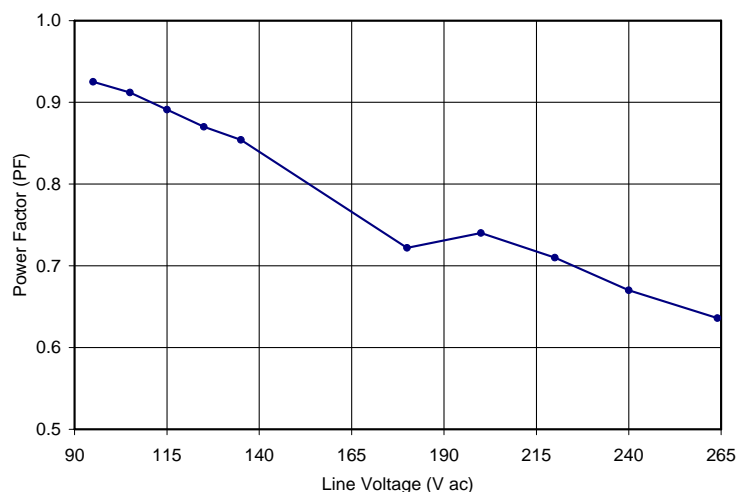

**Figure 5: Power Factor vs. Line Voltage
 $T_a = 20\text{ }^\circ\text{C}$, $P_{out} = 8.0\text{ W}$**

Component changes on NCP1014LEDR2GEVB Evaluation Board

Designator	Original Value	New Value	New Part Number	Manufacturer
C1	10 nF 270 Vac	100 nF 275 Vac	ECQ-U2A104ML	Panasonic
C2	4.7 μ F 400 Vdc	Not Used	-	-
C3	4.7 μ F 400 Vdc	220 nF 275 Vac	ECQ-U2A224ML	Panasonic
C5A, C5B	470 μ F 25 Vdc	1000 μ F 25Vdc	ECA-1EM102	Panasonic
C7	100 pF 100 Vdc	47 μ F 16Vdc	ECA-1CM470	Panasonic
D6	1 A 60 V dc	3 A 100Vdc	MBR3100	ON Semiconductor
L1	1 mH @ 250 mA	2.7 mH	RFB0810-272	Coilcraft
R3A	3.6 ohm 5%	5.1 ohm 5%	-	Various
R3B	3.6 ohm 5%	1 ohm 5%	-	Various
R4	100 ohm 5%	200 ohm 5%	-	Various
R5	200 ohm 5%	2.2 K 5%	-	Various

Conclusions

The modifications outlined in this design note improved the power factor from 0.597 to 0.861. This is well above the minimum power factor recommended by DOE Energy Star® Standard for Solid State lighting Luminaires for residential applications. LED current was increased to match performance requirements of the specific LEDs utilized in this example. As seen in the table below the input capacitance has been substantially reduced while the output capacitance has been doubled to keep the ripple well below the maximum current (700 mA) of the specific LED used in this design note.

Bibliography and References

- ENERGY STAR® Solid State Lighting (SSL) Luminaires requirements:
http://www.energystar.gov/index.cfm?c=revisions.ssl_luminaires
- ON Semiconductor's evaluation Board [NCP1014LEDR2GEVB](#): 360 mA, 24 V, Universal Input, Isolated Constant Current, LED driver

© 2009 ON Semiconductor.

Disclaimer: ON Semiconductor is providing this design note "AS IS" and does not assume any liability arising from its use; nor does ON Semiconductor convey any license to its or any third party's intellectual property rights. This document is provided only to assist customers in evaluation of the referenced circuit implementation and the recipient assumes all liability and risk associated with its use, including, but not limited to, compliance with all regulatory standards. ON Semiconductor may change any of its products at any time, without notice.

Design note created by Jim Young, email: james.young@onsemi.com