

NB3N502DEVB

NB3N502DEVB Evaluation Board User's Manual



ON Semiconductor®

<http://onsemi.com>

EVAL BOARD USER'S MANUAL

Description

The NB3N502 Evaluation Board was designed to provide a flexible and convenient platform to quickly evaluate, characterize and verify the performance and operation of the NB3N502 PLL Clock Multiplier. This user's manual provides detailed information on the board's contents, layout and use, and it should be used in conjunction with the NB3N502 data sheet which contains full technical details on device specifications and operation (www.onsemi.com).

Board Features

- Fully Assembled Evaluation Board
- Accommodates the Electrical Characterization of the NB3N502 in the SOIC-8 Package

- Supports the Use of a 5 MHz to 27 MHz Through-hole or Surface Mount Crystal
- SMA Connectors are Provided for Auxiliary Input and Output Interfaces
- Incorporates Onboard Slide Switch Controlled Multiplier Select Pins, Minimizing Excess Cabling

This Evaluation Board Manual Contains

- Information on the NB3N502 Evaluation Board
- Appropriate Lab Setup
- Evaluation Board Layout
- Bill of Materials

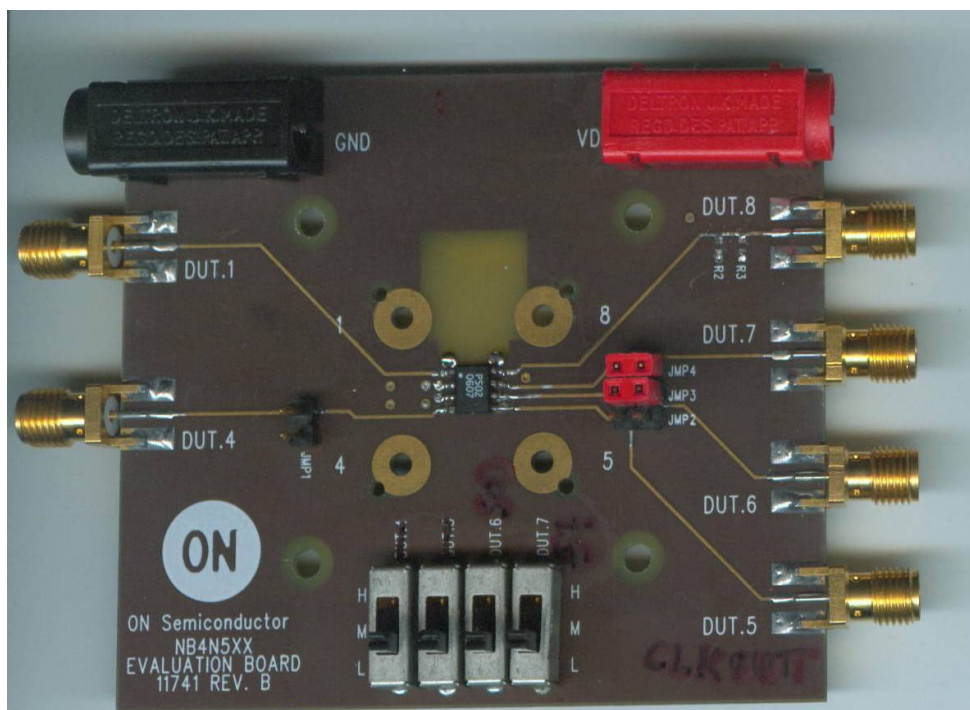

Figure 1. NB3N502 Evaluation Board

SETUP FOR MEASUREMENTS

Basic Equipment

- Signal Generator (for External Reference Clock Input)
- Oscilloscope
- Power Supply
- Voltmeter
- High-Speed Cables with SMA Connectors
- High-Impedance Probe

Power Supply Connections

External power supply of +3 V to +5.5 V must be provided to the board.

The NB4N502 has a positive supply pin, V_{DD}, and a ground pin, GND. Connect a single power supply to the evaluation board (see Figure 2.) by connecting V_{DD} to the positive supply, +3 V to +5.5 V, and GND to 0 V. Power supply banana plug connectors for V_{DD} and GND are provided at the top corners of the board.

Table 1. POWER SUPPLY CONNECTIONS

| Supply | Value | Connector |
|-----------------|--------------|-------------------|
| V _{DD} | +3 to +5.5 V | Red Banana Plug |
| GND | 0 V | Black Banana Plug |

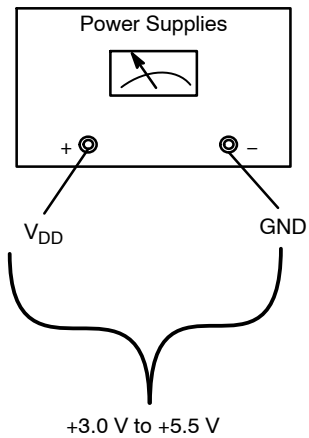

Figure 2. Power Supply Connections

External Reference Clock

An SMA connector is provided for X1/CLK if an external clock source is used on Pin 1. The metal trace at the package pin is intentionally open for crystal use and must be shorted for a connection to Pin 1 for external clock use.

Crystal and Crystal Load Capacitors Selection Guide

A through-hole or surface mount crystal can be used. The metal traces at the crystal pins are intentionally open for crystal use and will have no impedance effect on the crystal pins.

The total on-chip capacitance is approximately 12 pF per pin (C_{IN1} and C_{IN2}). A parallel resonant, fundamental

mode crystal should be used. The evaluation board includes pads for small capacitors from X1/CLK to ground and from X2 to ground. These capacitors, CL1 and CL2, are used to adjust the stray capacitance of the board to match the nominally required crystal load capacitance (CLOAD (crystal)). Crystal load capacitors must be connected from each of the pins X1 and X2 to ground. The load capacitance of the crystal (CLOAD (crystal)) must be matched by total load capacitance of the oscillator circuitry network, C_{INX}, CSX and CLX, as seen by the crystal (see Figure 3 and equations below).

$$CLOAD1 = C_{IN1} + CS1 + CL1$$

[Total capacitance on X1/CLK]

$$CLOAD2 = C_{IN2} + CS2 + CL2$$

[Total capacitance on X2]

$$C_{IN1} \approx C_{IN2} \approx 12 \text{ pF (Typ) [Internal capacitance]}$$

$$CS1 \approx CS2 \approx 5 \text{ pF (Typ) [External PCB stray capacitance]}$$

$$CLOAD_{1,2} = 2 - CLOAD \text{ (Crystal)}$$

$$CL2 = CLOAD2 - C_{IN2} - CS2$$

[External load capacitance on X2]

$$CL1 = CLOAD1 - C_{IN1} - CS1$$

[External load capacitance on X1/CLK]

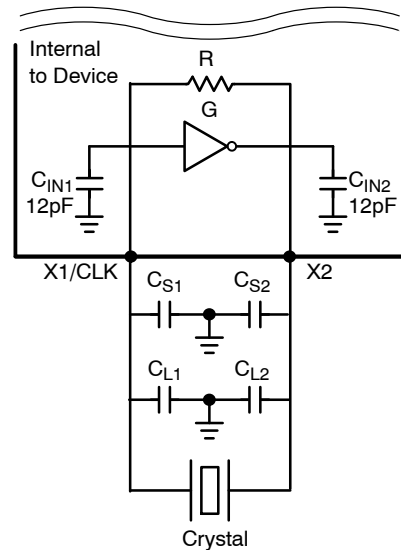

Figure 3. Using a Crystal as Reference Clock

Control and Select Pins

The NB4N502 evaluation board is equipped with SMA connectors to control the static input logic levels of the Multiplier Select pins, S0 and S1 (see Table 2).

Pin S1 defaults to M when left open. Pin S0 defaults to H when left open.

3-Position slide switches are also provided to control the Multiplier Select pins. To use the switches, headers JMP3 and JMP4 must be shorted.

NB3N502DEVB

1. Using the SMA Connectors

- SMA connectors J3 and J4 (DUT.6 and DUT.7) should be pulled to V_{CC} for logic level HIGH, pulled to GND for logic level LOW, and left OPEN for logic level M.

2. Using the Slide Switches

- Header pins JMP3 and JMP4 enable the slide switches for the clock multiplier select lines, S0 and S1, and should be jumpered.
- Switches SW3 (DUT.6) and SW4 (DUT.7) are used to select the clock multiplier value (see Table 2).
- The H position of the slide switch asserts a logic HIGH on the assigned pin, the L asserts a logic LOW and the M is an open where the pin “floats” to a mid-logic level by way of the device’s internal pullup and pulldown resistors.

Table 2. CLOCK MULTIPLIER SELECT TABLE

| S1* SW4 (DUT.7) | S0** SW3 (DUT.6) | Multiplier |
|--------------------|---------------------|------------|
| L | L | 2X |
| L | H | 5X |
| M | L | 3X |
| M | H | 3.33X |
| H | L | 4X |
| H | H | 2.5X |

L = GND, H = V_{DD} , M = OPEN (unconnected)

*Pin S1 defaults to M when left open

** Pin S0 defaults to H when left open

Table 3. HEADER PIN CONDITIONS

| Header | Slide Switch Multiplier Control | SMA Multiplier Control |
|--------|------------------------------------|---------------------------|
| JMP1 | Open | Open |
| JMP2 | Open | Open |
| JMP3 | Jumper (Short Pins) | Open |
| JMP4 | Jumper (Short Pins) | Open |

Output Connections

Connect the CMOS/TTL outputs, REF and CLKOUT, to the oscilloscope.

Table 4. OUTPUT CONNECTORS

| Outputs | Board Connector |
|---------|-----------------|
| REF | J1 (DUT.4) |
| CLKOUT | J2 (DUT.5) |

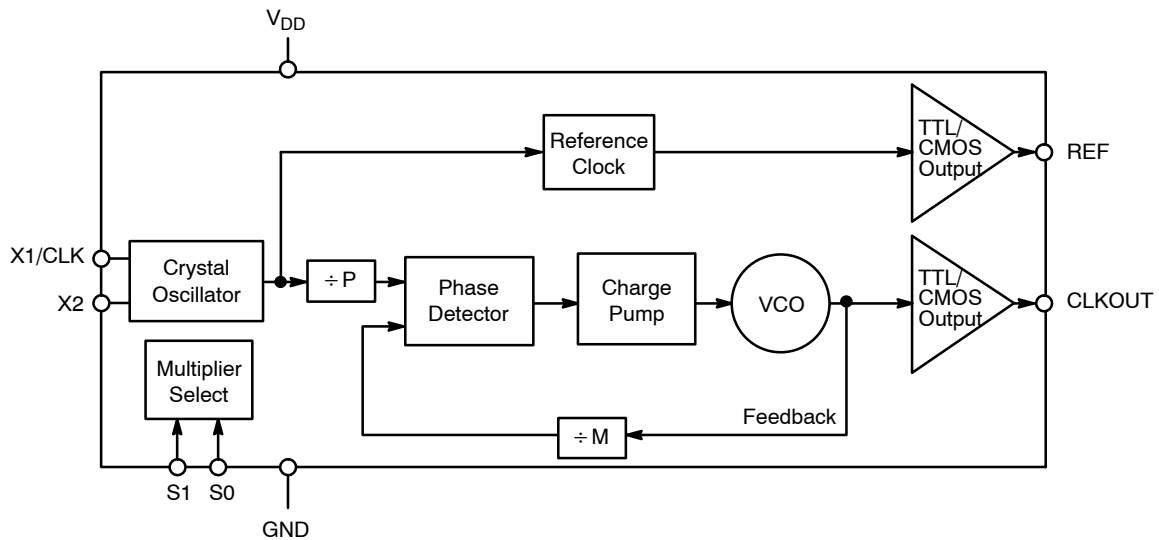

Figure 4. NB3N502 Logic Diagram

NB3N502DEVB

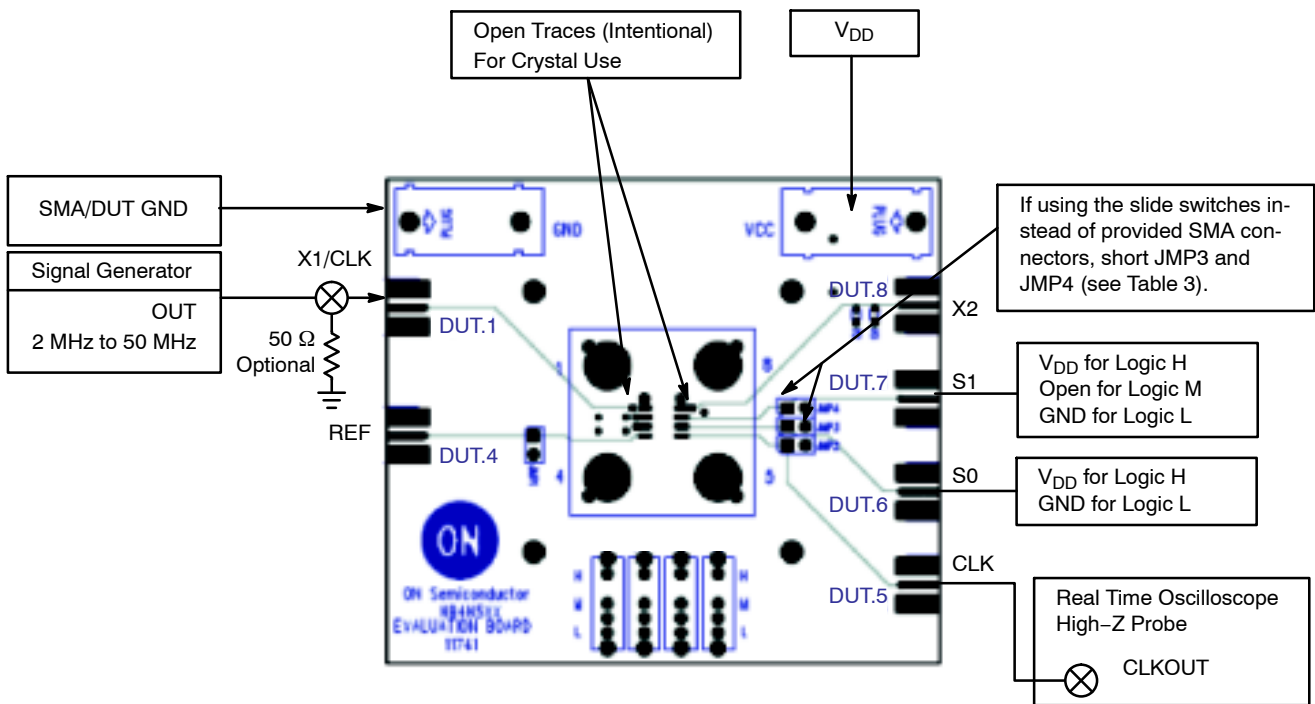

Figure 5. Typical Setup

Table 5. PARTS LIST

| Ref. Number | Qty | Description | Manufacturer (Notes 1 and 2) |
|----------------------|-----|--|------------------------------|
| R1 | 1 | Not populated | |
| R2 | 1 | Not populated | |
| R3 | 1 | Not populated | |
| C1 | 1 | Not populated | |
| C2 | 1 | Not populated | |
| C9 | 1 | 22 μ F \pm 10%, Size "C" Tantalum Capacitor, T494C226K016AT | KEMET |
| C10 | 1 | 0.01 μ F \pm 10%, (0603), Ceramic Capacitors, 06035C103KAT2A | AVX |
| C11 | 1 | 0.1 μ F \pm 10%, (0603), Ceramic Capacitors, 06035C104KAT2A | AVX |
| Y1 | 1 | 25 MHz Crystal | |
| U1 | 1 | NB3N502, 8 pin SOIC (Pb-Free) | ON Semiconductor |
| SW1 – SW4 | 4 | Slide Switches, 3 Position Miniature, OS103011MS8QP1 | C&K |
| J1 – J6 | 6 | SMA Edge Mount Connectors, 142-0711-821 | Johnson |
| JMP1–JMP4 | 4 | Jumper Header, 100 mil, 2 pins, 1 row, SPC20485 | SPC |
| V _{DD} Plug | 1 | Banana Plug, Red, 571-0500 | Deltron |
| GND Plug | 1 | Banana Plug, Black, 571-0100 | Deltron |

1. Specified parts are RoHS Compliant.
2. Only RoHS compliant parts may be substituted.

NB3N502DEVB

BOARD LAYOUT

The evaluation board is constructed with Getek material with 50 Ω trace impedances and is designed to minimize noise, achieve high bandwidth and minimize crosstalk.

Layer Stack

- L1 Signal
- L2 Ground
- L3 V_{DD}
- L4 Signal

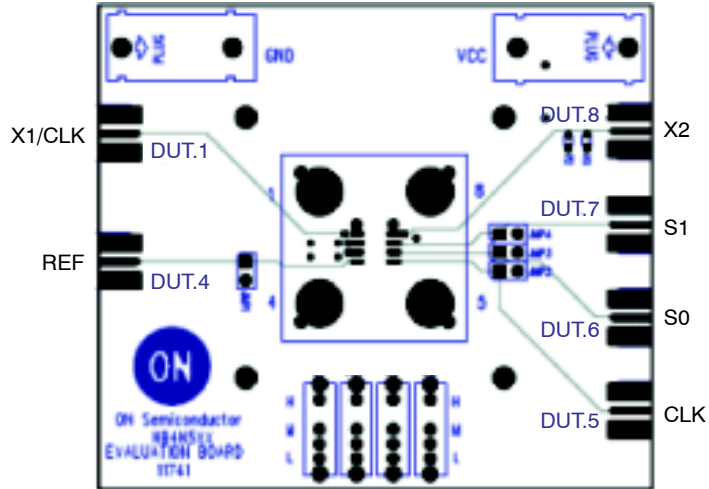

Figure 6. NB3N502 Evaluation Board Top (Component) Layer

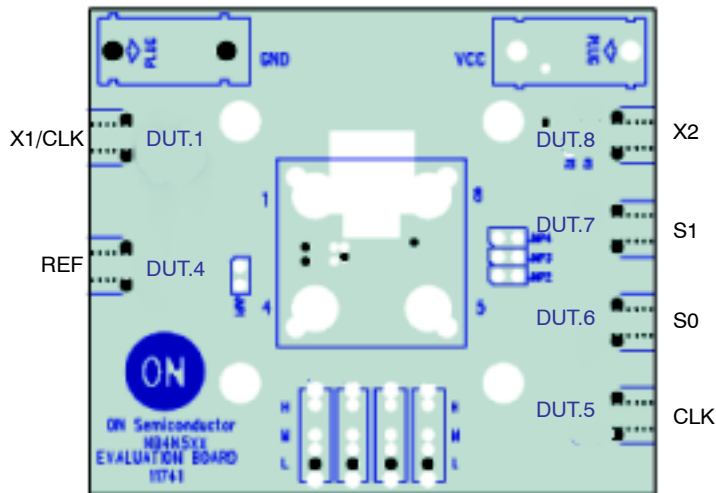

Figure 7. NB3N502 Evaluation Board SMA – Ground Layer

NB3N502DEVB

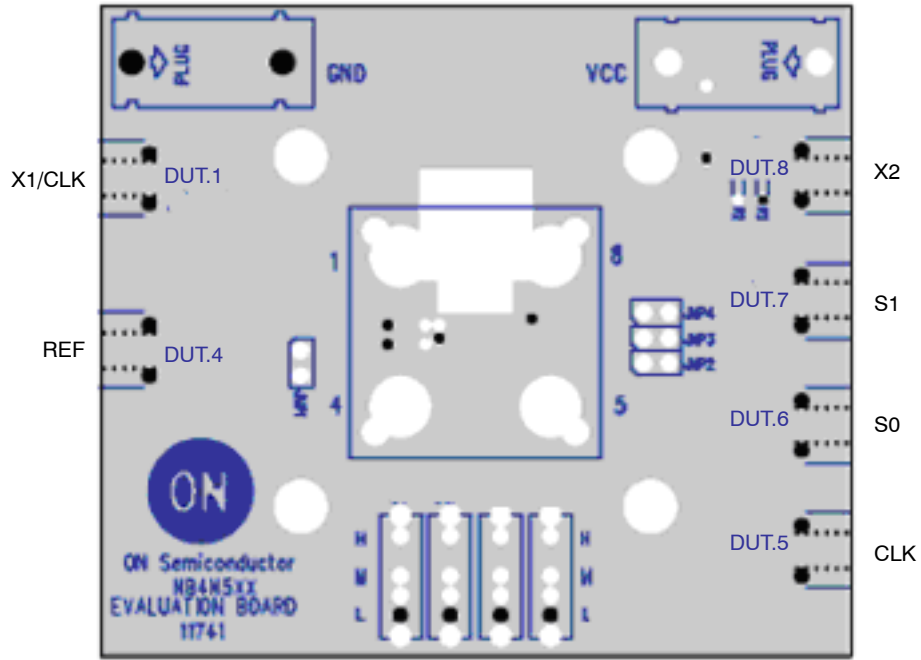

Figure 8. NB3N502 Evaluation Board Power Layer

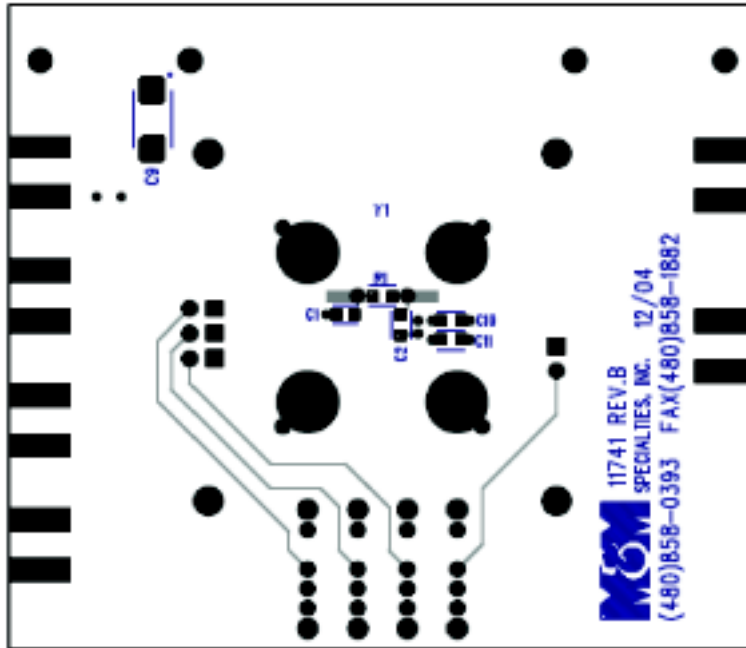

Figure 9. NB3N502 Evaluation Board Bottom Layer

NB3N502DEVB

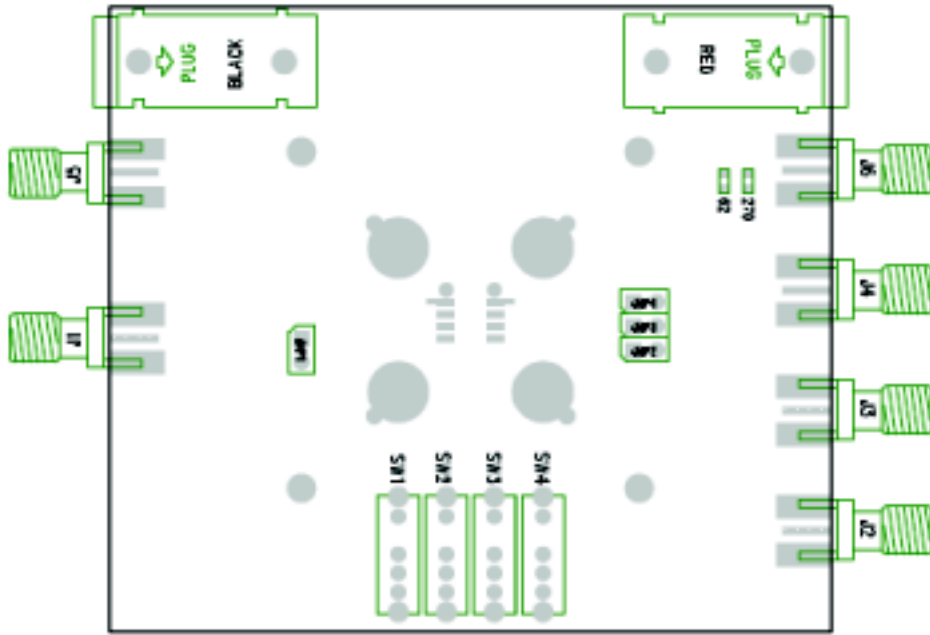

Figure 10. NB3N502 Evaluation Board Top Assembly

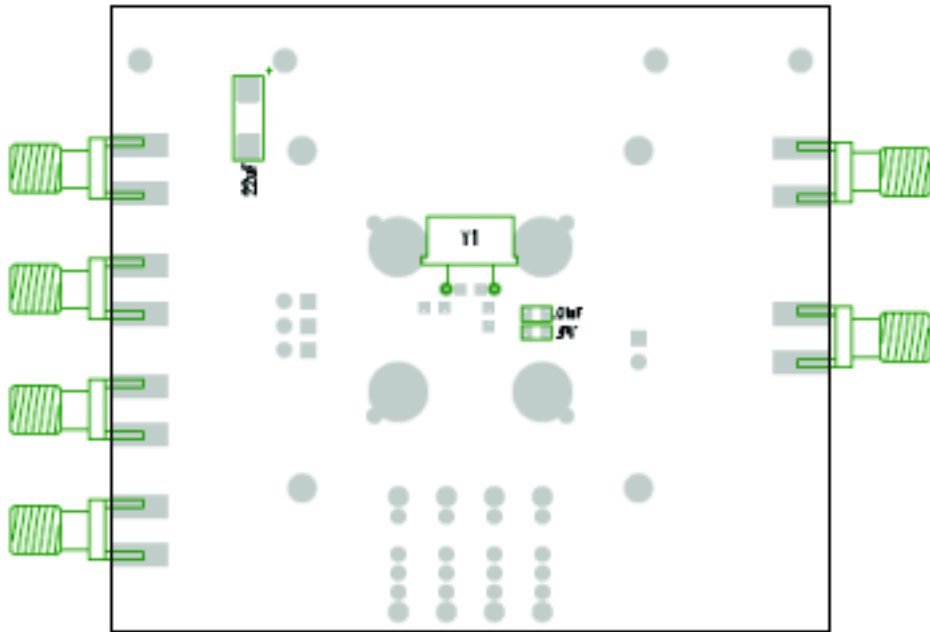

Figure 11. NB3N502 Evaluation Board Bottom Assembly

onsemi, **Onsemi**, and other names, marks, and brands are registered and/or common law trademarks of Semiconductor Components Industries, LLC dba "**onsemi**" or its affiliates and/or subsidiaries in the United States and/or other countries. **onsemi** owns the rights to a number of patents, trademarks, copyrights, trade secrets, and other intellectual property. A listing of **onsemi**'s product/patent coverage may be accessed at www.onsemi.com/site/pdf/Patent-Marking.pdf. **onsemi** is an Equal Opportunity/Affirmative Action Employer. This literature is subject to all applicable copyright laws and is not for resale in any manner.

The evaluation board/kit (research and development board/kit) (hereinafter the "board") is not a finished product and is not available for sale to consumers. The board is only intended for research, development, demonstration and evaluation purposes and will only be used in laboratory/development areas by persons with an engineering/technical training and familiar with the risks associated with handling electrical/mechanical components, systems and subsystems. This person assumes full responsibility/liability for proper and safe handling. Any other use, resale or redistribution for any other purpose is strictly prohibited.

THE BOARD IS PROVIDED BY ONSEMI TO YOU "AS IS" AND WITHOUT ANY REPRESENTATIONS OR WARRANTIES WHATSOEVER. WITHOUT LIMITING THE FOREGOING, ONSEMI (AND ITS LICENSORS/SUPPLIERS) HEREBY DISCLAIMS ANY AND ALL REPRESENTATIONS AND WARRANTIES IN RELATION TO THE BOARD, ANY MODIFICATIONS, OR THIS AGREEMENT, WHETHER EXPRESS, IMPLIED, STATUTORY OR OTHERWISE, INCLUDING WITHOUT LIMITATION ANY AND ALL REPRESENTATIONS AND WARRANTIES OF MERCHANTABILITY, FITNESS FOR A PARTICULAR PURPOSE, TITLE, NON-INFRINGEMENT, AND THOSE ARISING FROM A COURSE OF DEALING, TRADE USAGE, TRADE CUSTOM OR TRADE PRACTICE.

onsemi reserves the right to make changes without further notice to any board.

You are responsible for determining whether the board will be suitable for your intended use or application or will achieve your intended results. Prior to using or distributing any systems that have been evaluated, designed or tested using the board, you agree to test and validate your design to confirm the functionality for your application. Any technical, applications or design information or advice, quality characterization, reliability data or other services provided by **onsemi** shall not constitute any representation or warranty by **onsemi**, and no additional obligations or liabilities shall arise from **onsemi** having provided such information or services.

onsemi products including the boards are not designed, intended, or authorized for use in life support systems, or any FDA Class 3 medical devices or medical devices with a similar or equivalent classification in a foreign jurisdiction, or any devices intended for implantation in the human body. You agree to indemnify, defend and hold harmless **onsemi**, its directors, officers, employees, representatives, agents, subsidiaries, affiliates, distributors, and assigns, against any and all liabilities, losses, costs, damages, judgments, and expenses, arising out of any claim, demand, investigation, lawsuit, regulatory action or cause of action arising out of or associated with any unauthorized use, even if such claim alleges that **onsemi** was negligent regarding the design or manufacture of any products and/or the board.

This evaluation board/kit does not fall within the scope of the European Union directives regarding electromagnetic compatibility, restricted substances (RoHS), recycling (WEEE), FCC, CE or UL, and may not meet the technical requirements of these or other related directives.

FCC WARNING – This evaluation board/kit is intended for use for engineering development, demonstration, or evaluation purposes only and is not considered by **onsemi** to be a finished end product fit for general consumer use. It may generate, use, or radiate radio frequency energy and has not been tested for compliance with the limits of computing devices pursuant to part 15 of FCC rules, which are designed to provide reasonable protection against radio frequency interference. Operation of this equipment may cause interference with radio communications, in which case the user shall be responsible, at its expense, to take whatever measures may be required to correct this interference.

onsemi does not convey any license under its patent rights nor the rights of others.

LIMITATIONS OF LIABILITY: **onsemi** shall not be liable for any special, consequential, incidental, indirect or punitive damages, including, but not limited to the costs of requalification, delay, loss of profits or goodwill, arising out of or in connection with the board, even if **onsemi** is advised of the possibility of such damages. In no event shall **onsemi**'s aggregate liability from any obligation arising out of or in connection with the board, under any theory of liability, exceed the purchase price paid for the board, if any.

The board is provided to you subject to the license and other terms per **onsemi**'s standard terms and conditions of sale. For more information and documentation, please visit www.onsemi.com.

PUBLICATION ORDERING INFORMATION

LITERATURE FULFILLMENT:

Email Requests to: orderlit@onsemi.com

onsemi Website: www.onsemi.com

TECHNICAL SUPPORT

North American Technical Support:

Voice Mail: 1 800-282-9855 Toll Free USA/Canada

Phone: 011 421 33 790 2910

Europe, Middle East and Africa Technical Support:

Phone: 00421 33 790 2910

For additional information, please contact your local Sales Representative