

## X-Cube Imaging System X-Cube XGS 12000 Imager Board User's Manual

### X-CUBE XGS 12000 IMAGER BOARD OVERVIEW

The X-Cube Imaging System (X-Cube) is designed to demonstrate the features of ON Semiconductor's XGS family of image sensors in machine vision applications. The X-Cube is designed to conform to the machine vision industry standard 29 mm × 29 mm form factor.

This XGS 12000 Imager Board is designed to be compatible with the X-Cube Imaging System and fits in the 29 mm × 29 mm form factor C-Mount lens housing.

This imager board provides a good starting point for those about to initiate a small format camera design based on the XGS family of imager sensors.

For more information about the X-Cube, please refer to the X-Cube Imaging System Developer Guide. (AND9891/D)

### FEATURES

- XGS 12000 Global Shutter Image Sensor
- 12 Lane HiSpi Packetized-SP Sensor Output Mode Implementation
- 1" Optical Format
- C-Mount Lens Housing  
(29 mm × 29 mm Form Factor)
- 26 mm × 26 mm PCB Sized to Fit the Industry Standard  
29 mm × 29 mm Camera Case and Lens Mount
- Supports both Free-Running and Externally Triggered Operating Modes
- Supports Slave Mode Read Out Operation
- Operates off of a Single +3.3 V Power Supply Supplied by the Host
- A Host Controlled I<sup>2</sup>C Interface is used to Configure and Operate the Imaging System

This X-Cube demonstration and evaluation platform includes an imager board housed in a machine vision industry standard form factor 29 mm × 29 mm C-mount lens housing. For the color X-Cube option an integrated IR-Cut filter is also provided and is installed in the lens housing prior to the installation of the imager board. The lens mount housing design includes the option to attach a mounting post to the lens housing that enables the attachment of the lens housing to any tripod with a 1/4 inch sized mounting screw.

All of the PCB design files (schematic and PCB layout files) as well as the lens housing mechanical files are available to customers (NDA is required) to enable and accelerate the design of a customized camera based on the XGS family of image sensors.

For information on how to obtain the design files please contact the ON Semiconductor technical support team in your region.



ON Semiconductor®

[www.onsemi.com](http://www.onsemi.com)

### Eval Board User's Manual

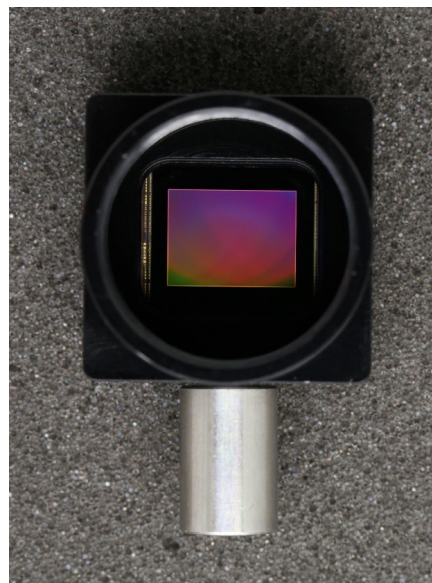
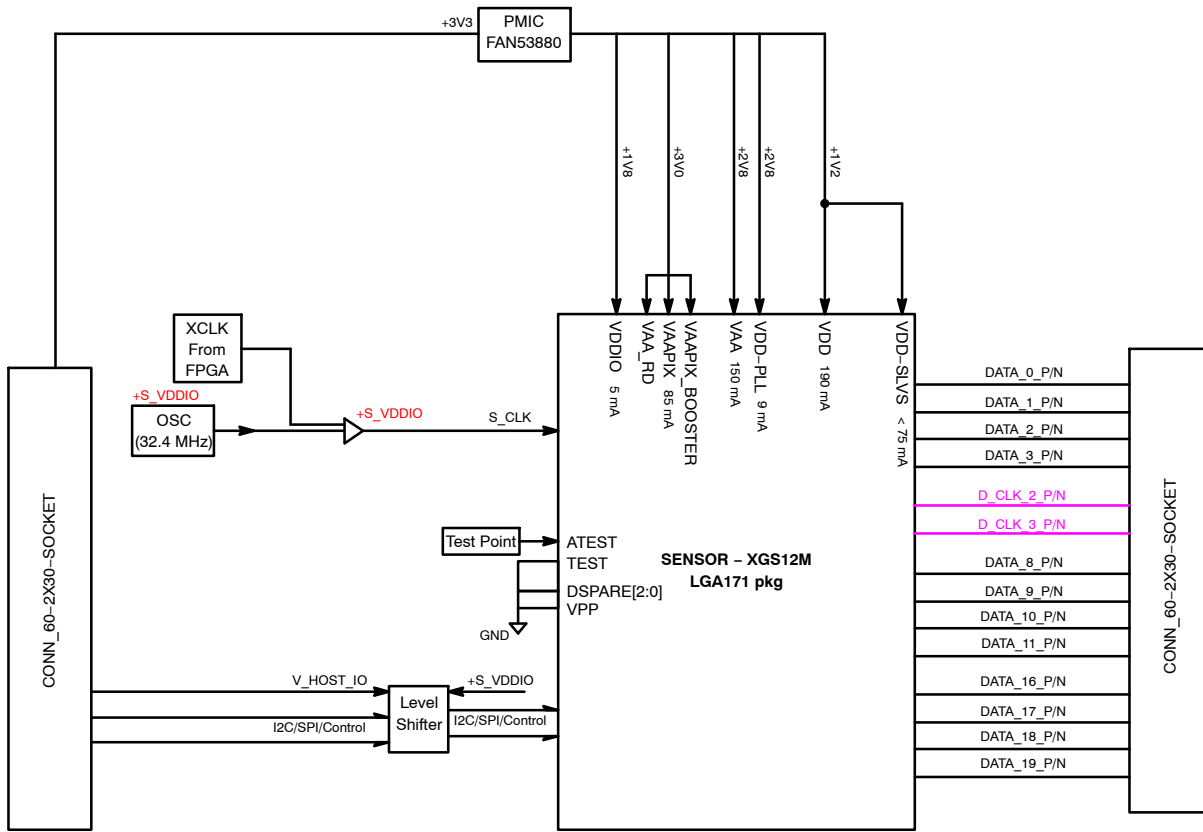

Figure 1. X-Cube XGS 12000 Imager Board Installed in the Lens Mount Housing

**Block Diagram**

The board block diagram is shown in Figure 2.



**Figure 2. X-Cube-XGS 12000-GEVB Block Diagram**

**C-mount Lens Housing**

The C-Mount Lens Housing is shown in Figure 3. The lens housing is designed to hold the imager board. The external dimensions of the lens housing are 29 mm × 29 mm.

For X-Cubes with color imagers, an IR-Cut filter is installed in the lens housing prior to the installation of the imager board. To secure the IR-Cut filter and avoid damage

to the image sensor, the filter is glued into a cavity provided in the Lens Mount Housing that was designed to accommodate the filter. The lens housing is designed to accommodate filters with a form factor of 20 mm × 20 mm and a thickness less than 3 mm.

The spectroscopic characteristics of the IR-Cut filter are shown in Table 1.

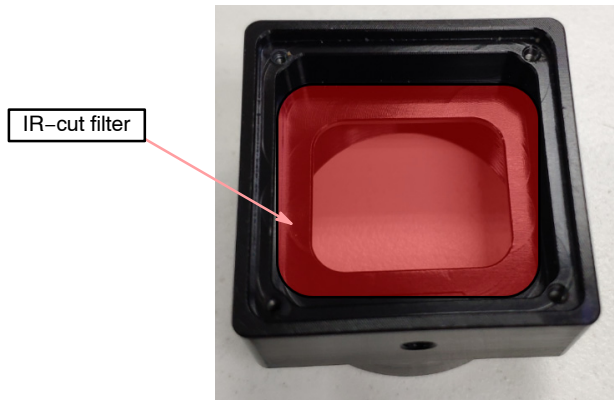

**Figure 3. C-Mount Lens Housing Shown with an IR-Cut Filter Installed**

**Table 1. IR-CUT FILTER SPECTROSCOPIC CHARACTERISTICS**

Wavelength (nm)	Transmission (T%)
420 – 620 nm	Tavg > 85%
650 ± 10 nm	T = 50%
720 – 1100 nm	Tmax < 2%

The Lens Mount Housing for the X-Cube is shown in Figure 4. The CAD design files (.DXF, .STP file formats) for the Lens Mount Housing are available to customers upon request (NDA is required).

For information on how to obtain the design files please contact the ON Semiconductor technical support team in your region.

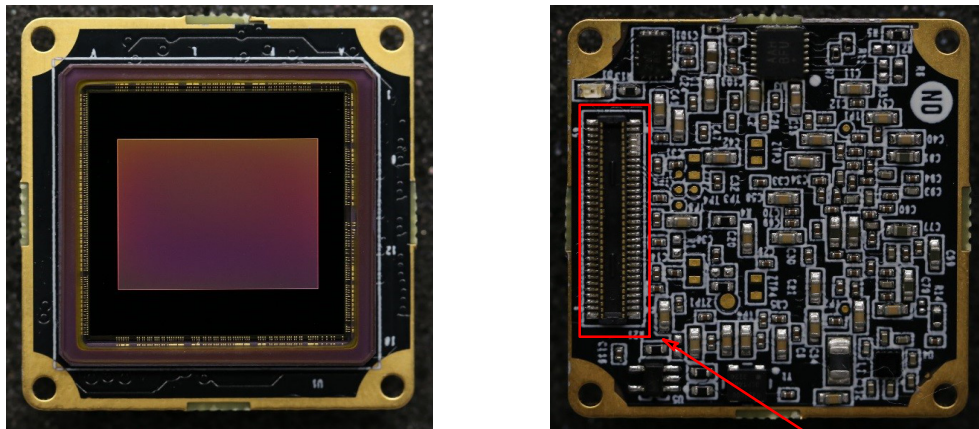

**Figure 4. X-Cube Lens Mount Housing Only: Top and Bottom View**

**Imager Board**

The XGS 12000 Imager Board for the X-Cube system is shown in Figure 5. The PCB design files (schematic and PCB layout files) for the imager board are available to customers upon request (NDA is required).

For information on how to obtain the design files please contact the ON Semiconductor technical support team in your region.



HiSPi Packetized-SP Mode Data Output Connector

**Figure 5. X-Cube XGS 12000 Imager Board Only: Top and Bottom View**

**Specification**

The X-Cube XGS 12000 Imager Board is designed to operate the XGS image sensor in HiSPi Packetized-SP mode format with a 12 lane output implementation.

The Imager Board requires only a single +3.3 V power supply input that is provided by the Host. The Imager Board utilizes an on-board power management IC (PMIC) designed by ON Semiconductor to generate all of the power supplies voltages required by the image sensor from the +3.3 V power supply input. Digital logic voltage level shifters are also included on the imager board to translate the 1.8 V I/O signal level required by the image sensor to the I/O signal

level voltage required by the Host. Please refer to the Imager Board schematic for detailed information on these circuits.

The configuration and control of both the image sensor and the PMIC is accomplished by way of an I2C interface that is controlled by the Host. Note that at power up, the PMIC is disabled. Therefore, at start up the first step is to enable the PMIC and then program the PMIC to provide the voltages required by the image sensor. After the PMIC output voltages have been programmed and stabilized, the image sensor is ready for register programming. Please refer to the Imager Board schematic and to the PMIC device datasheet for more information.

**Table 2. IMAGER BOARD SPECIFICATIONS**

Item	Definition	Min	Typ	Max	Unit
Lens mount	Lens Mount Housing accepts a C-Mount Type Lens				
IR-cut filter	For color modules only: An IR-Cut filter is installed in the Lens Mount Housing between the lens and the image sensor.				
Image sensor	Either XGS 12000 color or XGS 12000 monochrome				
Max frame rate	Frame rate at full resolution (12 Mpix)			57	fps
HiSPi Output Mode Implemented	Packetized-SP mode with 12 data lanes and 2 clock lanes (Top/Bottom)	6	12	12	lanes
HiSPi bitrate	Data rate per lane		777.6		Mbps
Image Sensor input clock	User Configurable: Can either use the 32.4 MHz oscillator on the Imager Board or supply this clock externally from the Host		32.4		MHz
VDD	Single power supply input to the Imager Board		3.3		V
IDD	Total current load of the Imager Board at max frame rate operation		500		mA
POWER	Power dissipation at max frame rate operation		1.65		W
External Trigger Modes	In addition to Free-Running Mode, Master Triggered mode and Slave Triggered mode of operation are also supported				

**REFERENCES**

- [1] AND9891/D (n.d.) X-Cube Imaging System  
X-Cube Machine Vision Reference Module  
Developer Guide.

**onsemi**, **Onsemi**, and other names, marks, and brands are registered and/or common law trademarks of Semiconductor Components Industries, LLC dba "**onsemi**" or its affiliates and/or subsidiaries in the United States and/or other countries. **onsemi** owns the rights to a number of patents, trademarks, copyrights, trade secrets, and other intellectual property. A listing of **onsemi**'s product/patent coverage may be accessed at [www.onsemi.com/site/pdf/Patent-Marking.pdf](http://www.onsemi.com/site/pdf/Patent-Marking.pdf). **onsemi** is an Equal Opportunity/Affirmative Action Employer. This literature is subject to all applicable copyright laws and is not for resale in any manner.

The evaluation board/kit (research and development board/kit) (hereinafter the "board") is not a finished product and is not available for sale to consumers. The board is only intended for research, development, demonstration and evaluation purposes and will only be used in laboratory/development areas by persons with an engineering/technical training and familiar with the risks associated with handling electrical/mechanical components, systems and subsystems. This person assumes full responsibility/liability for proper and safe handling. Any other use, resale or redistribution for any other purpose is strictly prohibited.

**THE BOARD IS PROVIDED BY ONSEMI TO YOU "AS IS" AND WITHOUT ANY REPRESENTATIONS OR WARRANTIES WHATSOEVER. WITHOUT LIMITING THE FOREGOING, ONSEMI (AND ITS LICENSORS/SUPPLIERS) HEREBY DISCLAIMS ANY AND ALL REPRESENTATIONS AND WARRANTIES IN RELATION TO THE BOARD, ANY MODIFICATIONS, OR THIS AGREEMENT, WHETHER EXPRESS, IMPLIED, STATUTORY OR OTHERWISE, INCLUDING WITHOUT LIMITATION ANY AND ALL REPRESENTATIONS AND WARRANTIES OF MERCHANTABILITY, FITNESS FOR A PARTICULAR PURPOSE, TITLE, NON-INFRINGEMENT, AND THOSE ARISING FROM A COURSE OF DEALING, TRADE USAGE, TRADE CUSTOM OR TRADE PRACTICE.**

**onsemi** reserves the right to make changes without further notice to any board.

You are responsible for determining whether the board will be suitable for your intended use or application or will achieve your intended results. Prior to using or distributing any systems that have been evaluated, designed or tested using the board, you agree to test and validate your design to confirm the functionality for your application. Any technical, applications or design information or advice, quality characterization, reliability data or other services provided by **onsemi** shall not constitute any representation or warranty by **onsemi**, and no additional obligations or liabilities shall arise from **onsemi** having provided such information or services.

**onsemi** products including the boards are not designed, intended, or authorized for use in life support systems, or any FDA Class 3 medical devices or medical devices with a similar or equivalent classification in a foreign jurisdiction, or any devices intended for implantation in the human body. You agree to indemnify, defend and hold harmless **onsemi**, its directors, officers, employees, representatives, agents, subsidiaries, affiliates, distributors, and assigns, against any and all liabilities, losses, costs, damages, judgments, and expenses, arising out of any claim, demand, investigation, lawsuit, regulatory action or cause of action arising out of or associated with any unauthorized use, even if such claim alleges that **onsemi** was negligent regarding the design or manufacture of any products and/or the board.

This evaluation board/kit does not fall within the scope of the European Union directives regarding electromagnetic compatibility, restricted substances (RoHS), recycling (WEEE), FCC, CE or UL, and may not meet the technical requirements of these or other related directives.

FCC WARNING – This evaluation board/kit is intended for use for engineering development, demonstration, or evaluation purposes only and is not considered by **onsemi** to be a finished end product fit for general consumer use. It may generate, use, or radiate radio frequency energy and has not been tested for compliance with the limits of computing devices pursuant to part 15 of FCC rules, which are designed to provide reasonable protection against radio frequency interference. Operation of this equipment may cause interference with radio communications, in which case the user shall be responsible, at its expense, to take whatever measures may be required to correct this interference.

**onsemi** does not convey any license under its patent rights nor the rights of others.

LIMITATIONS OF LIABILITY: **onsemi** shall not be liable for any special, consequential, incidental, indirect or punitive damages, including, but not limited to the costs of requalification, delay, loss of profits or goodwill, arising out of or in connection with the board, even if **onsemi** is advised of the possibility of such damages. In no event shall **onsemi**'s aggregate liability from any obligation arising out of or in connection with the board, under any theory of liability, exceed the purchase price paid for the board, if any.

The board is provided to you subject to the license and other terms per **onsemi**'s standard terms and conditions of sale. For more information and documentation, please visit [www.onsemi.com](http://www.onsemi.com).

## PUBLICATION ORDERING INFORMATION

### LITERATURE FULFILLMENT:

Email Requests to: [orderlit@onsemi.com](mailto:orderlit@onsemi.com)

**onsemi Website:** [www.onsemi.com](http://www.onsemi.com)

### TECHNICAL SUPPORT

**North American Technical Support:**

Voice Mail: 1 800-282-9855 Toll Free USA/Canada

Phone: 011 421 33 790 2910

**Europe, Middle East and Africa Technical Support:**

Phone: 00421 33 790 2910

For additional information, please contact your local Sales Representative