

ON Semiconductor

Is Now

onsemi™

To learn more about onsemi™, please visit our website at
www.onsemi.com

onsemi and **onsemi** and other names, marks, and brands are registered and/or common law trademarks of Semiconductor Components Industries, LLC dba "**onsemi**" or its affiliates and/or subsidiaries in the United States and/or other countries. **onsemi** owns the rights to a number of patents, trademarks, copyrights, trade secrets, and other intellectual property. A listing of **onsemi** product/patent coverage may be accessed at www.onsemi.com/site/pdf/Patent-Marking.pdf. **onsemi** reserves the right to make changes at any time to any products or information herein, without notice. The information herein is provided "as-is" and **onsemi** makes no warranty, representation or guarantee regarding the accuracy of the information, product features, availability, functionality, or suitability of its products for any particular purpose, nor does **onsemi** assume any liability arising out of the application or use of any product or circuit, and specifically disclaims any and all liability, including without limitation special, consequential or incidental damages. Buyer is responsible for its products and applications using **onsemi** products, including compliance with all laws, regulations and safety requirements or standards, regardless of any support or applications information provided by **onsemi**. "Typical" parameters which may be provided in **onsemi** data sheets and/or specifications can and do vary in different applications and actual performance may vary over time. All operating parameters, including "Typicals" must be validated for each customer application by customer's technical experts. **onsemi** does not convey any license under any of its intellectual property rights nor the rights of others. **onsemi** products are not designed, intended, or authorized for use as a critical component in life support systems or any FDA Class 3 medical devices or medical devices with a same or similar classification in a foreign jurisdiction or any devices intended for implantation in the human body. Should Buyer purchase or use **onsemi** products for any such unintended or unauthorized application, Buyer shall indemnify and hold **onsemi** and its officers, employees, subsidiaries, affiliates, and distributors harmless against all claims, costs, damages, and expenses, and reasonable attorney fees arising out of, directly or indirectly, any claim of personal injury or death associated with such unintended or unauthorized use, even if such claim alleges that **onsemi** was negligent regarding the design or manufacture of the part. **onsemi** is an Equal Opportunity/Affirmative Action Employer. This literature is subject to all applicable copyright laws and is not for resale in any manner. Other names and brands may be claimed as the property of others.

TND6300/D

FL7740 and FL7760 Driver with Bluetooth Wireless Dimming Control (25 W)

- FL7740 CV PSR Driver IC
- FL7760 CC Buck Driver IC
- RSL10 Bluetooth® 5 Radio System-on-Chip (SoC)

Overview

This reference design guide describes the specification, theory of operation, test results and design reference of wireless smart dimming LED driver using FL7740, FL7760 and RSL10. The LED driver is composed of 50 W FL7740 PFC flyback and two channel FL7760 DC-DC buck in which each channel drives 25 W. Test results are obtained by using 25 W single channel of the FL7760 buck driver.

Key Features

- Accurate Constant LED Current Regulation
- Excellent Power Factor and THD with Sinusoidal Current Shape
- Wide PWM Dimming Range < 1 %

Specifications

Table 1. SPECIFICATIONS TABLE

Description	Symbol	Value	Comments
Input Voltage	$V_{IN.MIN}$	90 Vrms	Minimum AC Input Voltage
	$V_{IN.MAX}$	305 Vrms	Maximum AC Input Voltage
	$V_{IN.NOMINAL}$	120, 230, 277 Vac	Nominal AC Input Voltage
Output Current	$I_{OUT.NOMINAL}$	578.8 mA	$V_{DIM.max} = 3.3$ Vdc
	$I_{OUT.MIN.PDIM}$	3.74 mA (0.65%)	Min. PWM Dimming. Duty _{PWM} = 1%. Freq. _{PWM} = 2 kHz



ON Semiconductor®

www.onsemi.com

REFERENCE DESIGN

General Description of FL7740

The FL7740 provides accurate CV regulation in the steady state with differentiated dynamic function to minimize overshoot and undershoot of output voltage in line and load transient condition. Standby power is less than 0.3 W for smart lighting application and power factor is higher than 0.9 even at half load condition when enabling PF optimizer for wide output power scalability. Startup time is less than 0.2 s with built-in high voltage startup circuit and output voltage reaches to the target CV level by loop gain transition technique during startup. Various protections such as over load, output diode short, sensing resistor short, output short and over voltage protection guarantee high system reliability.

General Description of FL7760

The FL7760 is a high-efficiency step-down controller for middle to high power lighting applications that operate in Continuous Conduction Mode (CCM). The FL7760 employs hysteretic control with fixed reference architecture that accurately regulates LED current with a feedback coming from an external high-side current-sense resistor. This control scheme optimizes circuit stabilization and fast response time without loop compensation. This function optimizes to PWM dimming in order to remove current overshoot during PWM dimming. The FL7760 has a low average feedback voltage about 200 mV in order to reduce power loss and improves the converter's efficiency. The FL7760 implements PWM and analog dimming together through the DIM pin and provides thermal shutdown (TSD), and under-voltage lockout (UVLO) protections.

Bluetooth Controller: ON's Bluetooth Radio System-on-Chip

RSL10 is an ultra-low-power, highly flexible multi-protocol 2.4 GHz radio specifically designed for use in high-performance wearable and medical applications.

With its Arm® Cortex®-M3 Processor and LPDSP32 DSP core, RSL10 supports Bluetooth low energy technology and 2.4 GHz proprietary protocol stacks, without sacrificing power consumption.

The RSL10 Evaluation Board is used for evaluating the RSL10 SoC and for application development. The board provides access to all input and output connections via 0.1" standard headers. The on-board communication interface circuit provides communication to the board from a host PC. The communication interface translates RSL10 SWJ-DP debug port signals to the USB of the host PC. There is also an on-board 4-bit level shifter for debugging; it translates the I/O signal level of RSL10 to the 3.3 V digital logic level.

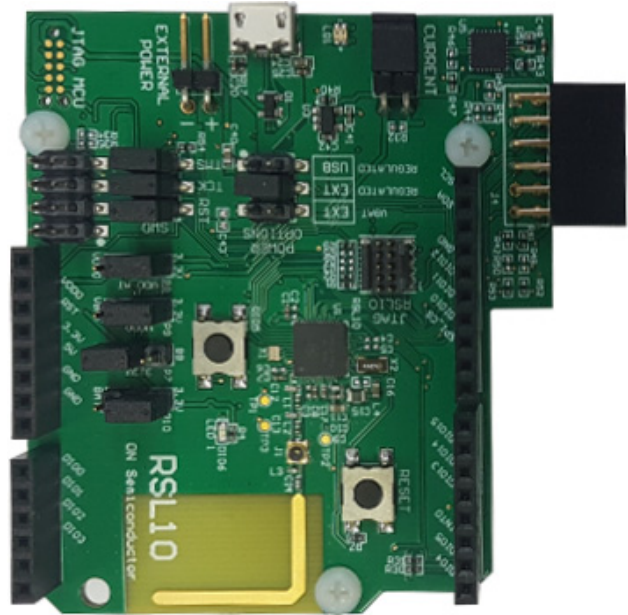

Figure 1. RSL10 Evaluation Board

TND6300/D

REFERENCE CIRCUIT FOR FL7740

FL7740 reference circuit is based on the 50 W reference design. R21 and R22 are modified circuit in this wireless dimming design.

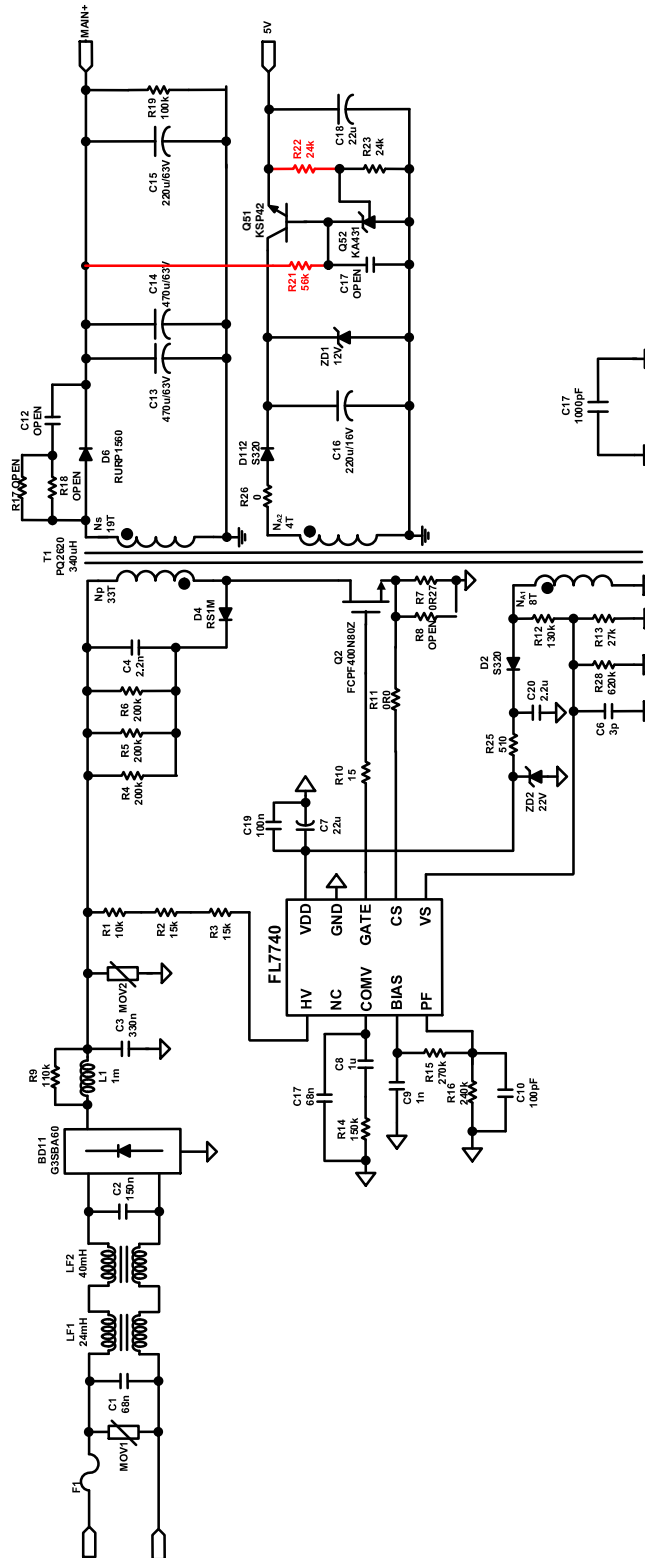

Figure 2. Reference Circuit for FL7740

TND6300/D

REFERENCE CIRCUIT FOR FL7760

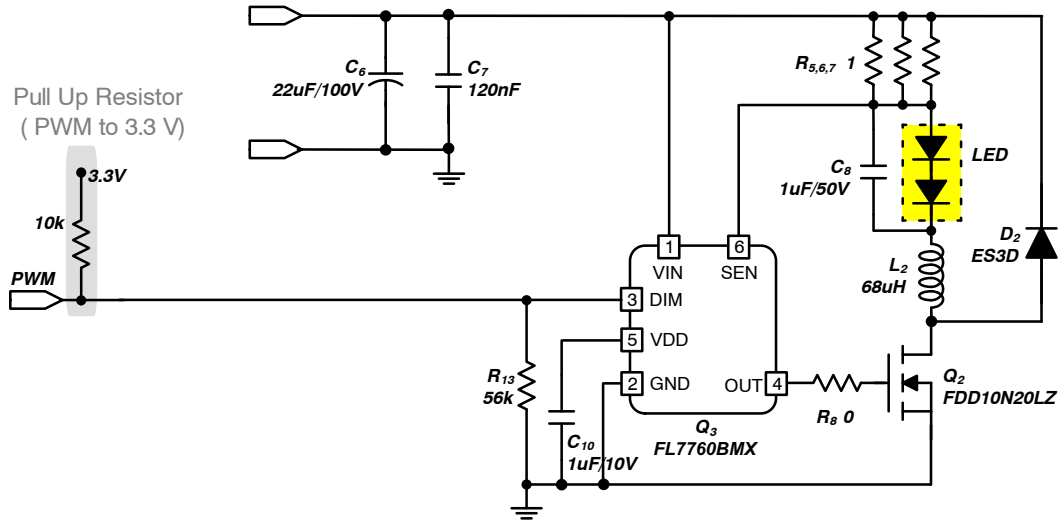

Figure 3. Reference Circuit for FL7760

PROGRAM INSTALL ON RSL10 EVALUATION BOARD

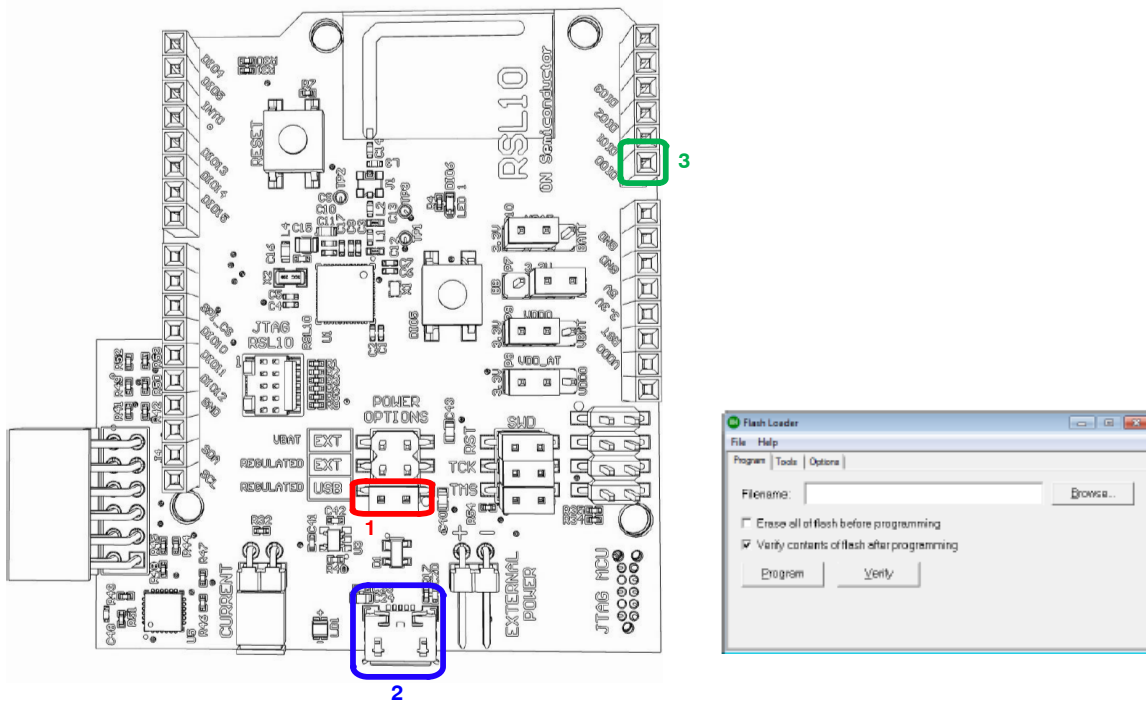

Figure 4. Hex File Installing

To set the board for testing of RSL10, follow the procedure below to hex file installing.

1. Connect the jumper connector to the USB port.
2. Connect the USB port to PC and start hex file loading to RSL10 EVB.
3. Check if PWM signal output is completed after loading.

When run the stand-alone flash loader with no command-line options, it operates in graphical mode. In this mode, the flash loader displays the graphical user interface shown in Figure 5. To use the RSL10 EVB, the J-link program must be updated to the latest version. The flash loader program and the FL7760 hex file can be downloaded from the ON Semiconductor website.

TND6300/D

Test Data – PWM Dimming Signal

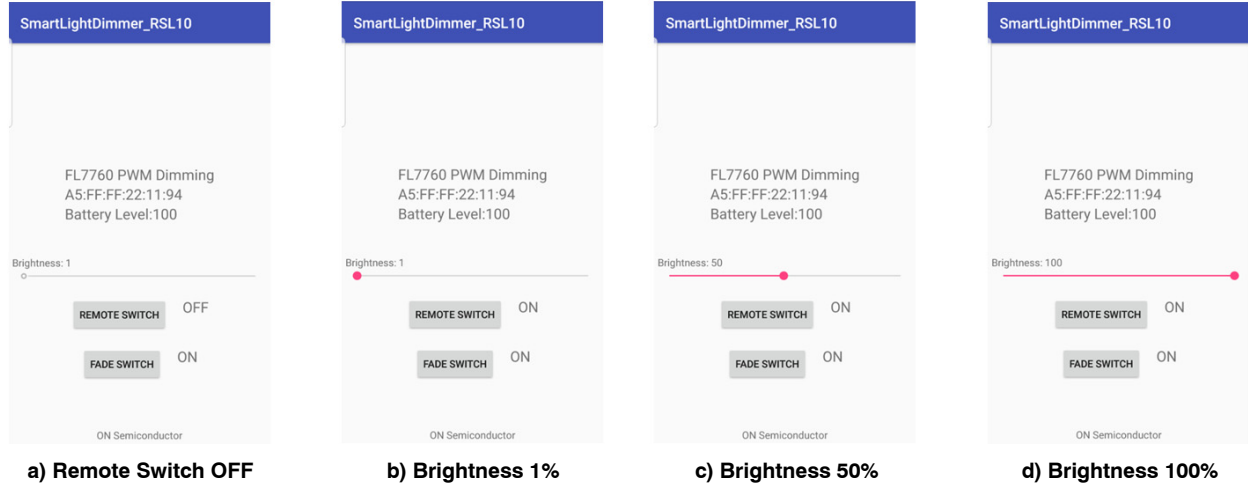
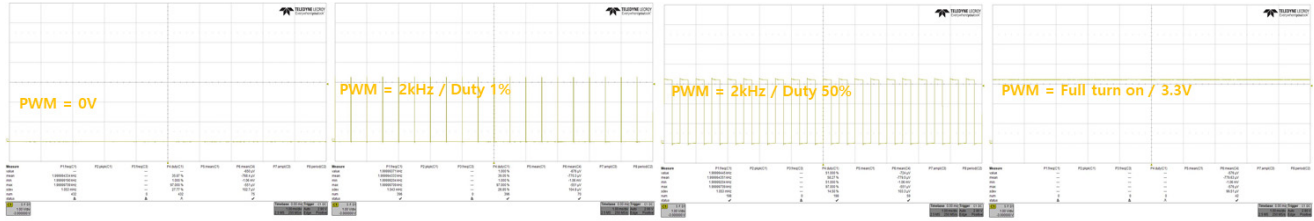

Figure 5. Dimming Signal Control by Android Application App

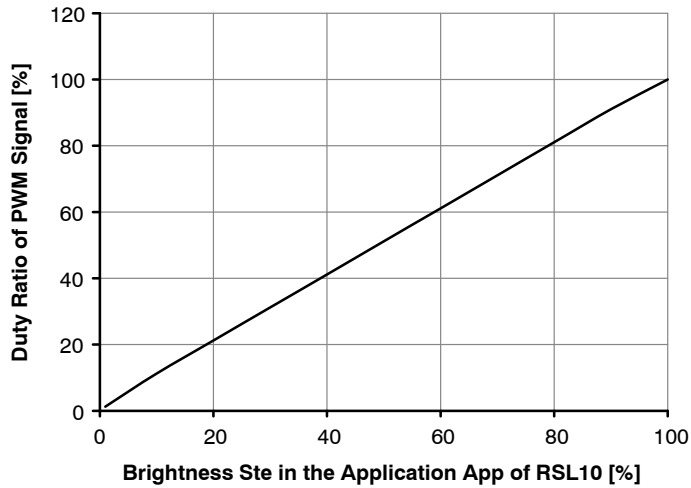

Figure 6. Brightness Set in the Android App of RSL10

The PWM signal frequency of RSL10 EVB is 2 kHz and duty ration is shown in Table 2.

Table 2. DUTY RATIO OF PWM SIGNAL

Brightness set in the Android App	100%	90%	80%	70%	60%	50%	40%	30%	20%	10%	1%
Duty for PWM1 (2 kHz)	100%	91%	81%	71%	61%	51%	41%	31%	21%	11%	1%
On Time [μs]	Full	455	405	355	305	255	205	155	105	55	5
Off Time [μs]	.	45	95	145	195	245	295	345	395	445	495

TND6300/D

Test Data – Basic Performance

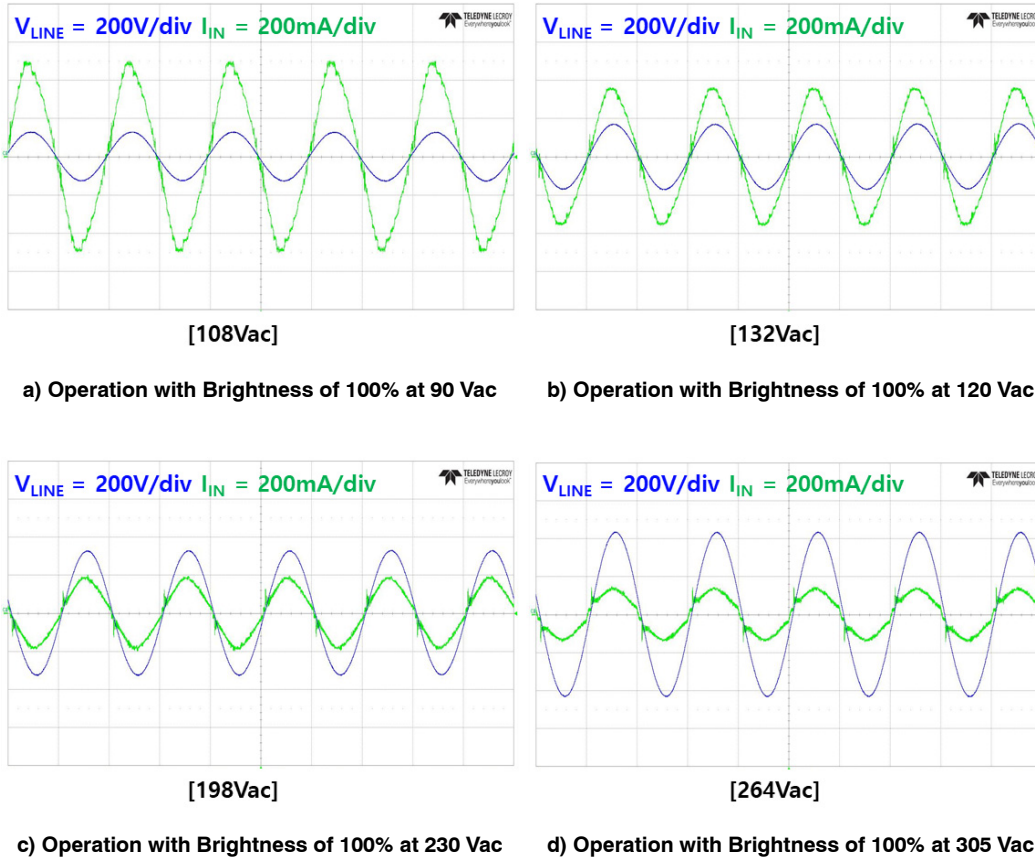

Figure 7. Basic Operation

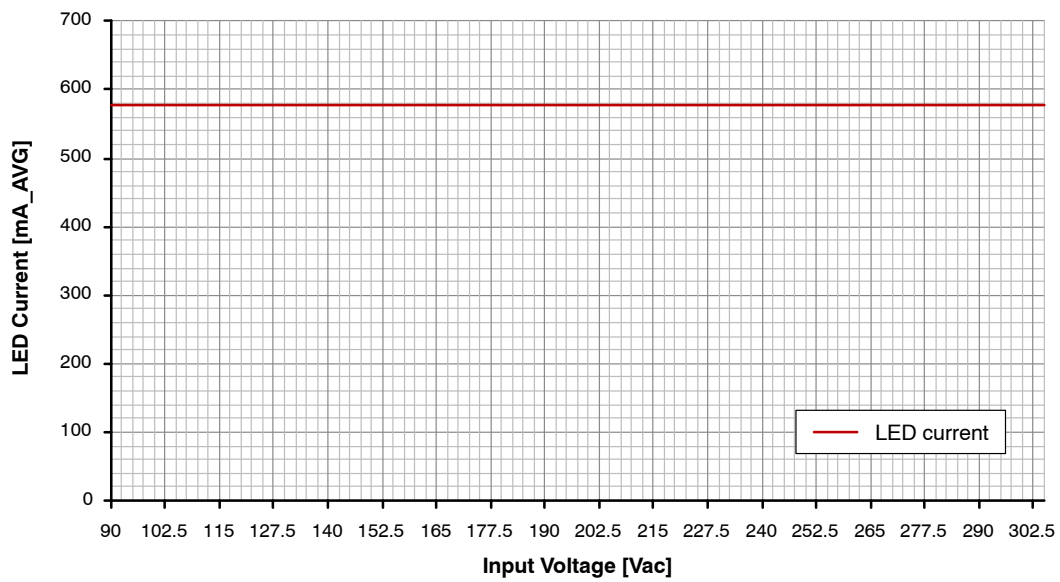

Figure 8. Line Regulation with Brightness of 100%

TND6300/D

Table 3. POWER FACTOR, THD AND INPUT POWER

Input Voltage [Vac]	LED Voltage [V]	LED Current [mA]	PF	THD [%]
90	43.1	578.8	0.997	7.2
120	43.1	578.8	0.995	6.6
220	43.1	578.8	0.991	7.5
277	43.1	578.8	0.980	10.8
305	43.1	578.4	0.973	13.4

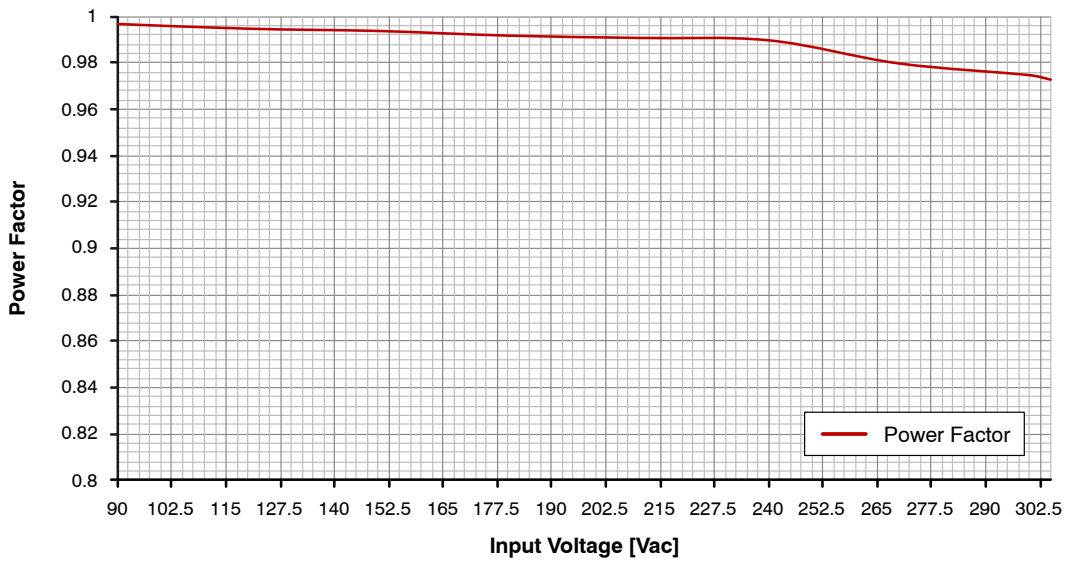

Figure 9. PF with Brightness of 100%

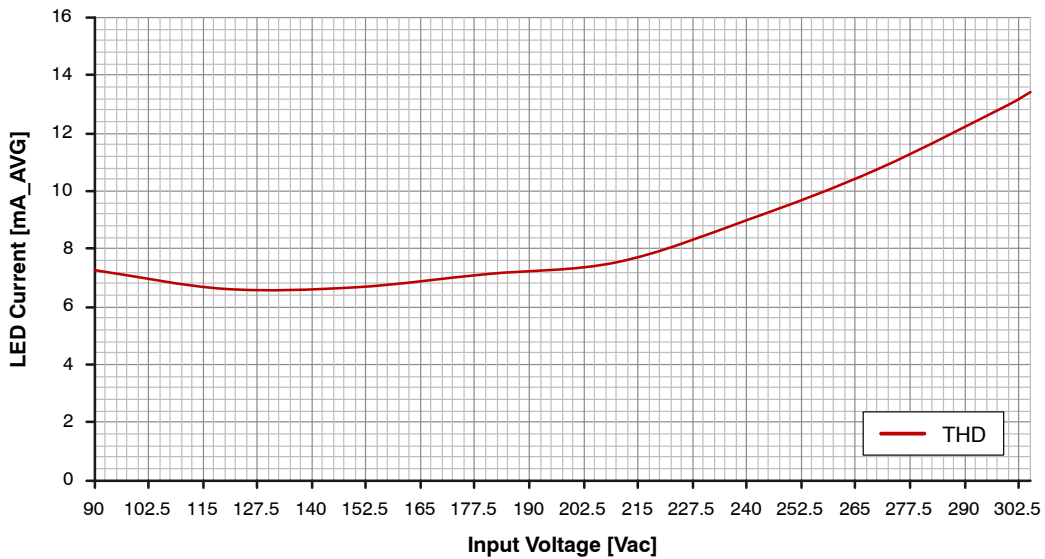

Figure 10. THD Performance

FL7740 PFC flyback is designed to drive 50 W and output load power in this test is 25 W. Even in the half load, PF is

over 0.97 and THD is less than 14% in the entire input voltage up to 305 Vrms.

TND6300/D

Test Data – Dimming Performance

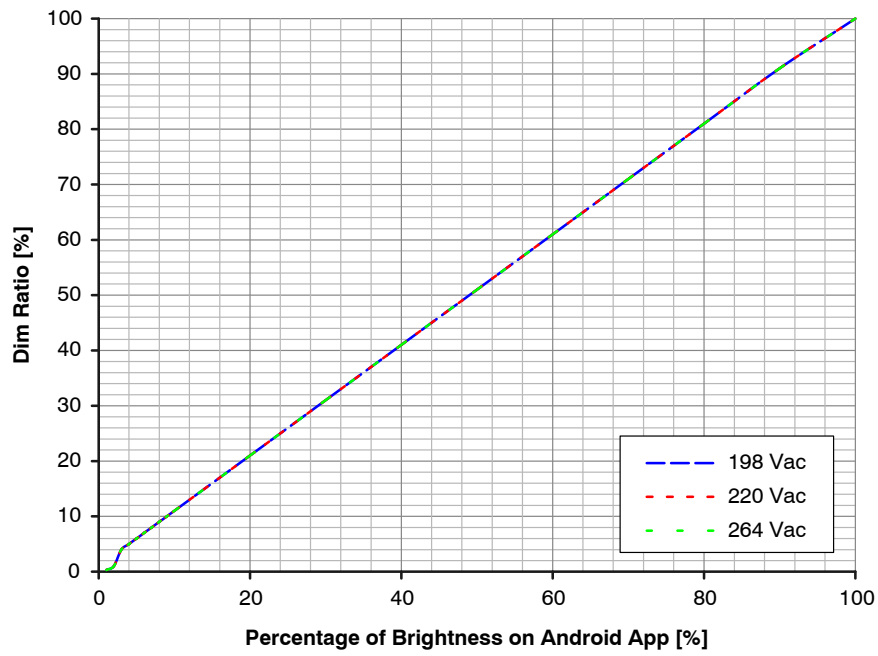
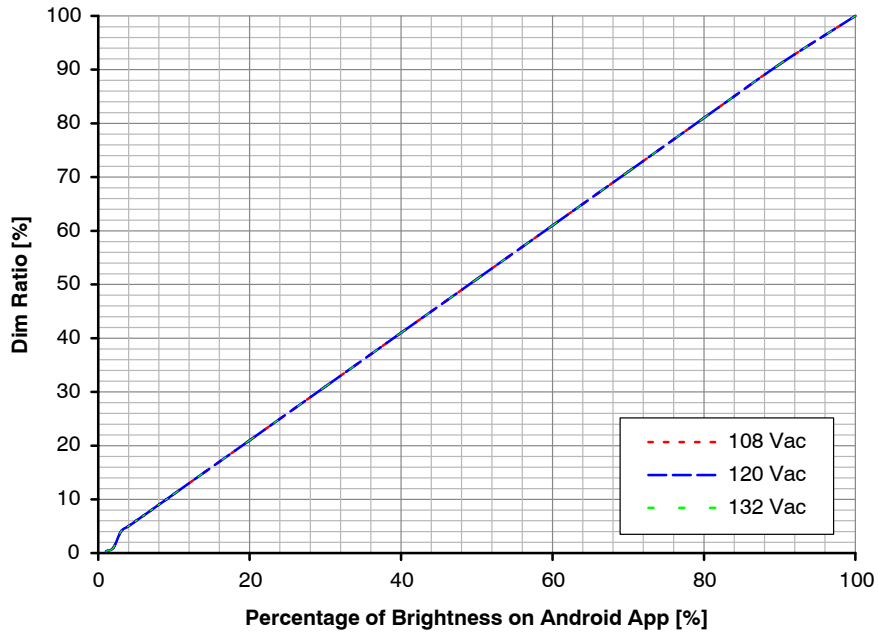

Figure 11. PWM Dimming Curve

APPENDIX

Hybrid Dimming

The FL7760 can implement hybrid dimming by adjusting amplitude and duty ratio of the single DIM signal provided

at DIM pin. It provides wide dimming range with good dimming linearity.

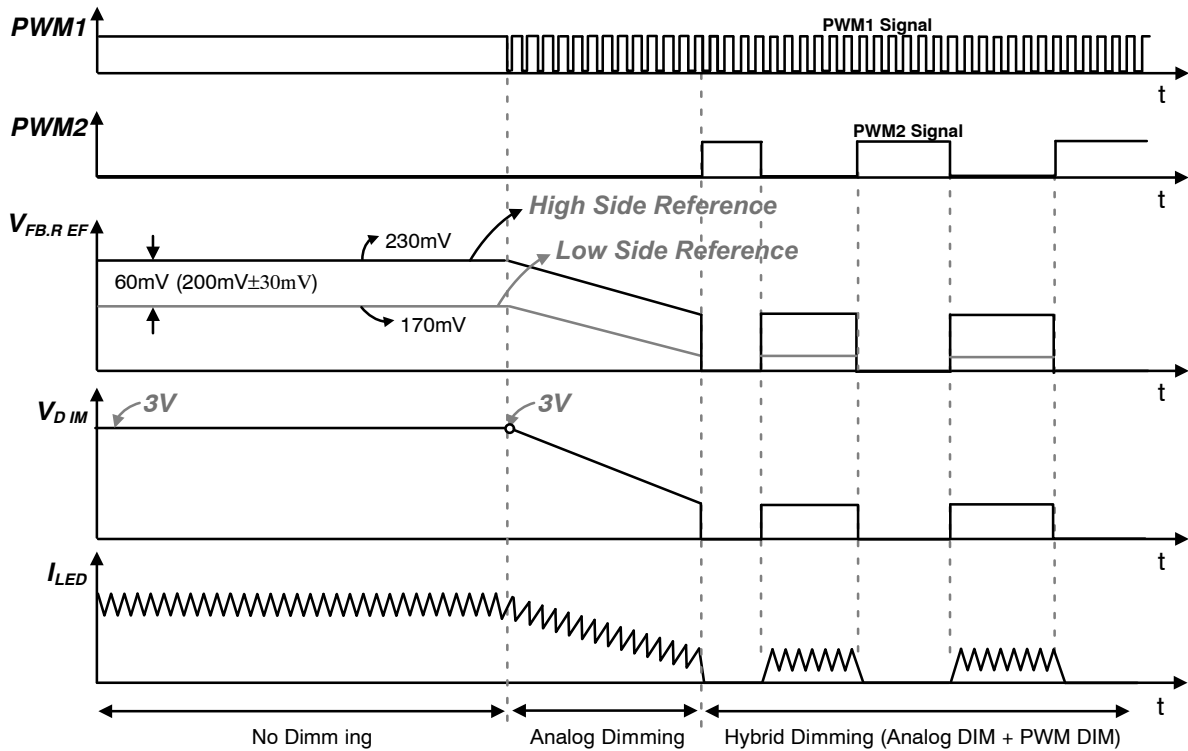
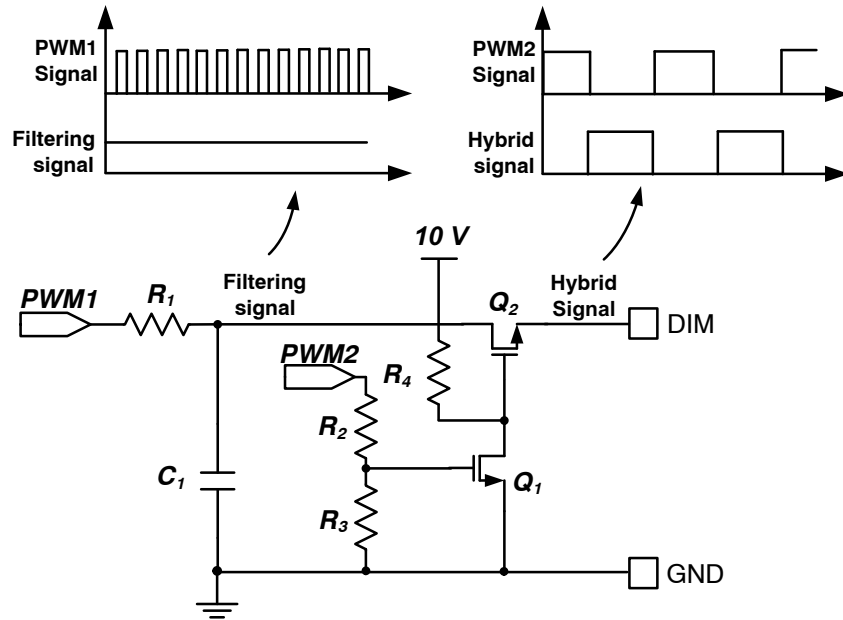

Figure 12. Hybrid Dimming Performance

Hybrid Dimming Circuit

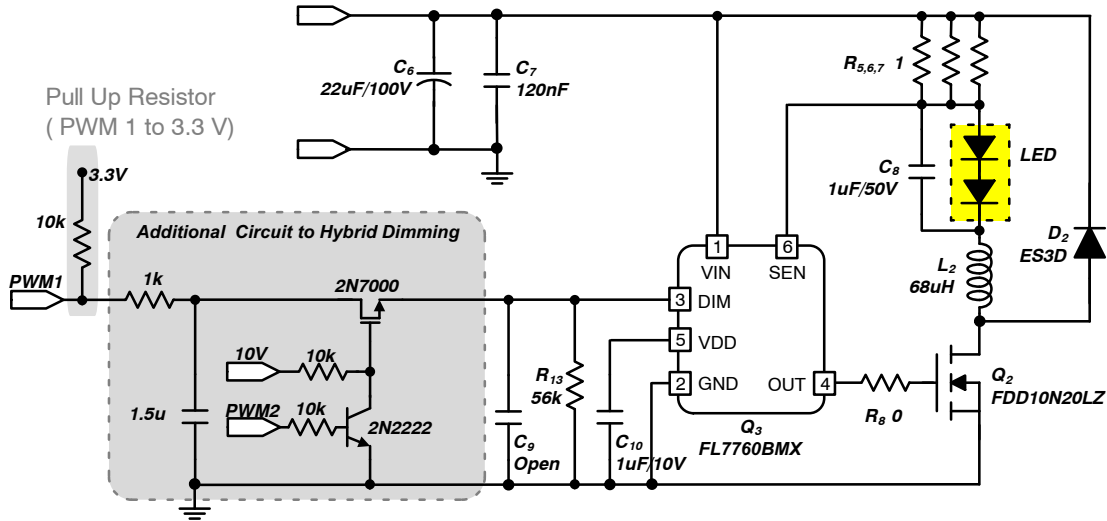

Figure 13. Hybrid Dimming Connection with FL7760

In hybrid dimming design, FL7760 DIM pin requires an additional circuit as shown in Figure 13. In the Android App provided by ON Semiconductor web, the frequencies of PWM1 and PWM2 are set at 20 kHz and 200 Hz. It is

recommended to use the B version of FL7760 for the linearity of the dimming curve.

The duty ratio of the PWM signals from RSL10 EVB is shown in Table 4.

Table 4. POWER FACTOR, THD AND INPUT POWER

Brightness set in the Android App	100%	90%	80%	70%	60%	50%	40%	30%	20%	10%	1%
Duty for PWM1 (20 kHz)	100%	90%	80%	70%	60%	50%	50%	50%	50%	50%	50%
Duty for PWM2 (200 Hz)	0%	0%	0%	0%	0%	0%	20%	40%	60%	80%	98%

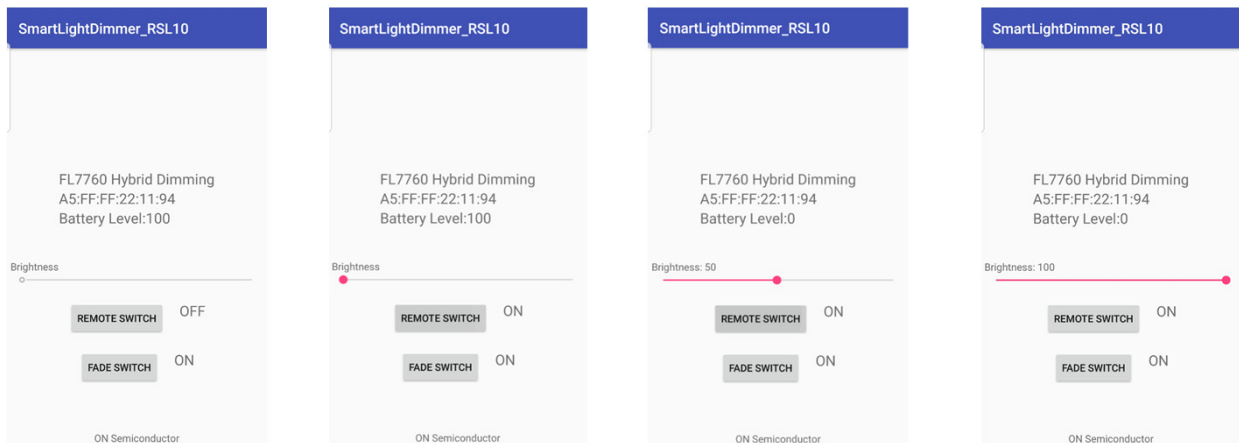
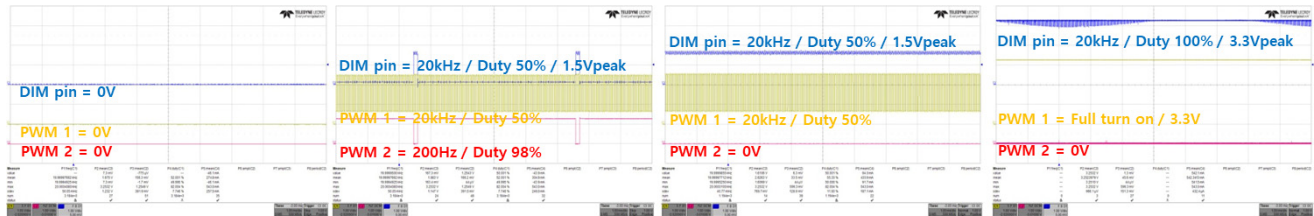

a) Remote Switch OFF

b) Brightness 1%

c) Brightness 50%

d) Brightness 100%

Figure 14. Dimming Signal Control by Android Application App

TND6300/D

PWM Controller

- FL7740: Constant Voltage, Primary Side Regulation for Power Factor Correction ([FL7740/D](#))
- FL7760: High-Side Sensing Constant Current Buck Controller for High Switching Frequency LED Driver ([FL7760/D](#))

RSL10 Bluetooth 5 Radio System-on-Chip (SoC)

- RSL10 Evaluation and Development Board User's Manual ([EVBUM2529/D](#))
- [RSL10-002GEVB Gerber](#)
- RSL10 Program (To be update)

Reference Designs

- FL7740: 50 W Constant Voltage Output Driver ([TND6255/D](#))
- FL7760: 2 Channel Dimmable Buck Driver ([TND6256/D](#))

Arm and Cortex are registered trademark of Arm Limited (or its subsidiaries) in the US and/or elsewhere.
Bluetooth is a registered trademark of Bluetooth SIG.

ON Semiconductor and  are trademarks of Semiconductor Components Industries, LLC dba ON Semiconductor or its subsidiaries in the United States and/or other countries. ON Semiconductor owns the rights to a number of patents, trademarks, copyrights, trade secrets, and other intellectual property. A listing of ON Semiconductor's product/patent coverage may be accessed at www.onsemi.com/site/pdf/Patent-Marking.pdf. ON Semiconductor reserves the right to make changes without further notice to any products herein. ON Semiconductor makes no warranty, representation or guarantee regarding the suitability of its products for any particular purpose, nor does ON Semiconductor assume any liability arising out of the application or use of any product or circuit, and specifically disclaims any and all liability, including without limitation special, consequential or incidental damages. Buyer is responsible for its products and applications using ON Semiconductor products, including compliance with all laws, regulations and safety requirements or standards, regardless of any support or applications information provided by ON Semiconductor. "Typical" parameters which may be provided in ON Semiconductor data sheets and/or specifications can and do vary in different applications and actual performance may vary over time. All operating parameters, including "Typicals" must be validated for each customer application by customer's technical experts. ON Semiconductor does not convey any license under its patent rights nor the rights of others. ON Semiconductor products are not designed, intended, or authorized for use as a critical component in life support systems or any FDA Class 3 medical devices or medical devices with a same or similar classification in a foreign jurisdiction or any devices intended for implantation in the human body. Should Buyer purchase or use ON Semiconductor products for any such unintended or unauthorized application, Buyer shall indemnify and hold ON Semiconductor and its officers, employees, subsidiaries, affiliates, and distributors harmless against all claims, costs, damages, and expenses, and reasonable attorney fees arising out of, directly or indirectly, any claim of personal injury or death associated with such unintended or unauthorized use, even if such claim alleges that ON Semiconductor was negligent regarding the design or manufacture of the part. ON Semiconductor is an Equal Opportunity/Affirmative Action Employer. This literature is subject to all applicable copyright laws and is not for resale in any manner.

PUBLICATION ORDERING INFORMATION

LITERATURE FULFILLMENT:

Literature Distribution Center for ON Semiconductor
19521 E. 32nd Pkwy, Aurora, Colorado 80011 USA
Phone: 303-675-2175 or 800-344-3860 Toll Free USA/Canada
Fax: 303-675-2176 or 800-344-3867 Toll Free USA/Canada
Email: orderlit@onsemi.com

N. American Technical Support: 800-282-9855 Toll Free
USA/Canada
Europe, Middle East and Africa Technical Support:
Phone: 421 33 790 2910

ON Semiconductor Website: www.onsemi.com

Order Literature: <http://www.onsemi.com/orderlit>

For additional information, please contact your local Sales Representative