



Is Now Part of



ON Semiconductor®

To learn more about ON Semiconductor, please visit our website at
www.onsemi.com

ON Semiconductor and the ON Semiconductor logo are trademarks of Semiconductor Components Industries, LLC dba ON Semiconductor or its subsidiaries in the United States and/or other countries. ON Semiconductor owns the rights to a number of patents, trademarks, copyrights, trade secrets, and other intellectual property. A listing of ON Semiconductor's product/patent coverage may be accessed at www.onsemi.com/site/pdf/Patent-Marking.pdf. ON Semiconductor reserves the right to make changes without further notice to any products herein. ON Semiconductor makes no warranty, representation or guarantee regarding the suitability of its products for any particular purpose, nor does ON Semiconductor assume any liability arising out of the application or use of any product or circuit, and specifically disclaims any and all liability, including without limitation special, consequential or incidental damages. Buyer is responsible for its products and applications using ON Semiconductor products, including compliance with all laws, regulations and safety requirements or standards, regardless of any support or applications information provided by ON Semiconductor. "Typical" parameters which may be provided in ON Semiconductor data sheets and/or specifications can and do vary in different applications and actual performance may vary over time. All operating parameters, including "Typicals" must be validated for each customer application by customer's technical experts. ON Semiconductor does not convey any license under its patent rights nor the rights of others. ON Semiconductor products are not designed, intended, or authorized for use as a critical component in life support systems or any FDA Class 3 medical devices or medical devices with a same or similar classification in a foreign jurisdiction or any devices intended for implantation in the human body. Should Buyer purchase or use ON Semiconductor products for any such unintended or unauthorized application, Buyer shall indemnify and hold ON Semiconductor and its officers, employees, subsidiaries, affiliates, and distributors harmless against all claims, costs, damages, and expenses, and reasonable attorney fees arising out of, directly or indirectly, any claim of personal injury or death associated with such unintended or unauthorized use, even if such claim alleges that ON Semiconductor was negligent regarding the design or manufacture of the part. ON Semiconductor is an Equal Opportunity/Affirmative Action Employer. This literature is subject to all applicable copyright laws and is not for resale in any manner.

AN-6605

Noise of Sources

INTRODUCTION

The elimination or minimization of noise is one of the most perplexing problems facing engineers today. Many preamplifiers and components come with outstanding noise specifications, only to disappoint the user. The problem is the difference between specification and application, as the amplifiers are specified under ideal conditions not the real conditions, (i.e., a transducer connected to the input). Many times the transducer noise is as large, or even greater than, the amplifier noise degrading the signal to noise ratio. Before amplifier or component noise can be considered, familiarity with the source noise is essential.

REVIEW OF NOISE BASICS

There are 3 types of transducers: resistive, capacitive and inductive. The noise of a passive network is thermal noise, generated by the real part of the complex impedance, as given by Nyquist's relation:

$$V_n^2 = 4kT\text{Re}(Z) \Delta f \quad (1)$$

Where:

$$V_n^2 = \text{Mean square noise voltage (V}^2\text{)}$$

$$k = \text{Boltzmann's constant (1.38x10}^{-23} \text{ VAS/}^\circ\text{K)}$$

$$T = \text{Absolute temperature (}^\circ\text{K)}$$

$$\text{Re}(Z) = \text{Real part of complex impedance (}\Omega\text{)}$$

$$\Delta f = \text{Noise bandwidth (Hz)}$$

The noise may be represented as a spectral density of (V^2/Hz) or more commonly in $\mu\text{V}/\sqrt{\text{Hz}}$ or $\text{nV}/\sqrt{\text{Hz}}$ and is given by:

$$e_n^2 = \frac{V_n^2}{\Delta f} \quad (2)$$

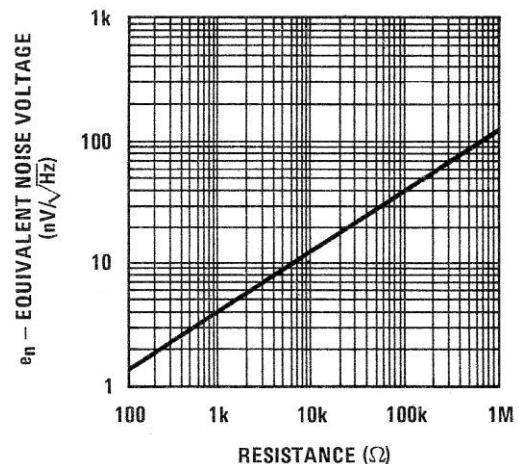

Figure 1. Thermal Noise Voltage vs. Resistance

The total noise voltage in a frequency band can be readily calculated if it is white noise (i.e., $\text{Re}(Z)$ is frequency independent). This is not the case for capacitive or inductive sources or most real world noise problems.

Rapidly changing network impedance and amplifier gain equalization combine to complicate the issue. The total source noise in a non-ideal case can be calculated by breaking the noise spectrum into several small bands where the noise ($\text{Re}(Z)$) is nearly white and calculating the noise of each band. The total source noise is the RMS sum of the noise in each of the bands N_1 - N_n .

$$V_{\text{NOISE}} = (V_{N_1}^2 + V_{N_2}^2 + \dots + V_{N_n}^2)^{1/2} \quad (3)$$

The expression does not take amplifier gain equalization (like RIAA) into account, which will change the character of the noise at the amplifier output. By reflecting the gain equalization to the amplifier input and normalizing the gain to 0 dB at 1 kHz, the equalized source noise may then be calculated.

$$V_{EQ} = (|A_1|^2 \frac{V_{N1}^2}{N_1} + |A_2|^2 \frac{V_{N2}^2}{N_2} + \dots + |A_n|^2 \frac{V_{Nn}^2}{N_n})^{1/2} \quad (4)$$

Where V_{EQ} = equalized source noise (μV) and $|A_n|$ = magnitude of the equalized gain at the center of each noise band (V/V).

SOURCE NOISE

Models are needed for capacitive and inductive systems such that noise calculations can be made. Namely, the real part of the impedance needs to be determined.

A lumped model of a capacitive source, such as condenser or electret microphone, consists of the microphone and stray capacitance shunted by a load resistance.

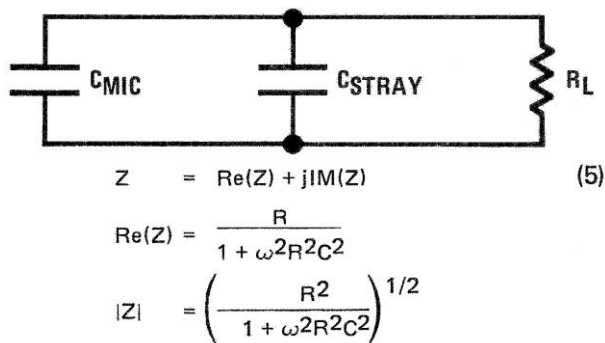

Figure 2. Lumped Model of a Capacitive Microphone

It should be noted that for any particular microphone, the noise of the network $((C_m + C_s)/R_L)$ is reduced by increasing R_L because $\text{Re}(Z)$ (the real part of the impedance) is inversely proportional to R_L (see equation 5).

The inductive source (phono cartridges and tape heads) is more complex to analyze because it has a much more complex model. The simplified lumped model of a phono cartridge or tape head consists of a series inductance and resistance shunted by a small capacitor. Each phono cartridge or tape head has a recommended load consisting of a specified shunt resistance and capacitance. A model for the inductive source and preamp input network is shown in Figure 3.

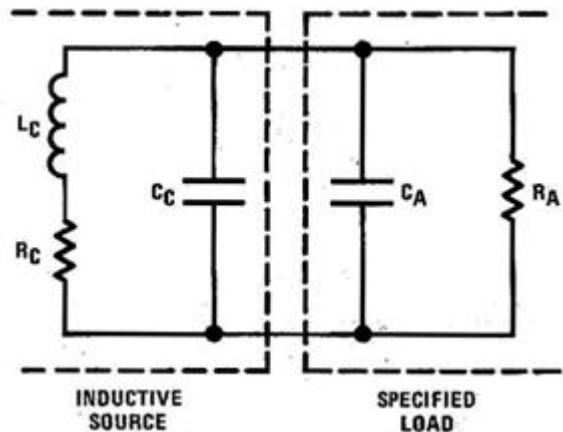
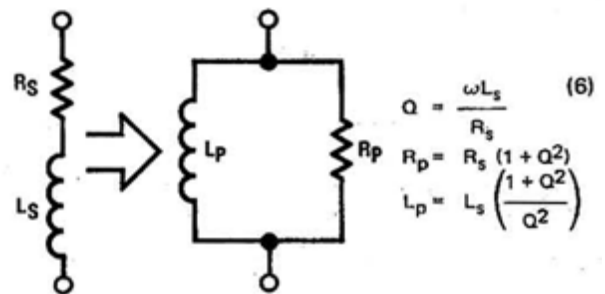

Figure 3. Phono Cartridge or Tape Head and Preamp Input Network

This circuit is quite formidable to analyze and needs, further simplification. Through the use of Q equations, a series L-R is transformed to a parallel L-R.



Simplifying the input network to:

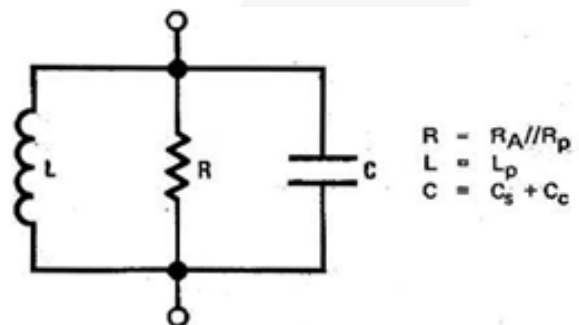

Figure 4. Simplified Inductive Source Network.

$$\text{Re}(Z) = \frac{RX_L^2 X_C^2}{(RX_L - RX_C)^2 + X_L^2 X_C^2} \quad (7)$$

$$Z = \frac{RX_L X_C}{((RX_L - RX_C)^2 + X_L^2 X_C^2)^{1/2}}$$

$$X_L = \omega L$$

$$X_C = 1/\omega C$$

The tools are now available to calculate the noise of a variety of transducers and see how this unspecified noise affects amplifier (S/N) performance.

EXAMPLES

Calculations of electret microphone noise with various loads and RIAA equalized phono cartridge noise is done using equations (1)—(7). Center frequencies and frequency bands must be chosen first. Values of the lumped circuit components calculated and noise calculated for each band, then summed for the total noise. Octave bandwidths starting at 25 Hz will be adequate for approximating the noise.

In this example, the microphone capacitance is 10 pF loaded with 5 pF of amplifier and stray capacitance. Two resistive loads will be used to illustrate the effect R_L has on the microphone noise. $R_{L1} = 1 \text{ G}\Omega$ (10^9), $R_{L2} = 10 \text{ G}\Omega$ (10^{10}). It is assumed that there is no gain equalization in the amplifiers that follow. The noise calculations are summarized in Table I.

The electret or condenser microphone noise ($\text{Re}(Z)$) is reduced when the load resistance is increased. This is one of the cases when a larger resistance means lower noise, not more noise.

The second example is the calculation of the RIAA equalized noise of an ADC 27 phono cartridge loaded with $C_A = 250 \text{ pF}$ and $R_A = 47 \text{ k}$. The cartridge constants are $R_s = 1.13 \text{ k}$ and $L_s = 0.75 \text{ H}$ (C_c may be neglected). The noise calculations are summarized in Table II for this example.

The RIAA equalized noise of the ADC 27 phono cartridge and preamp input network was $0.73 \mu\text{V}$ for the audio band. Typical high quality preamps have noise voltages less than $1 \mu\text{V}_v$ resulting in a 3 dB or more loss in system S/N ratio when the cartridge noise is added to the preamp noise (in an RMS fashion).

CONCLUSIONS

Zero noise sources and amplifiers do not exist. Specifying amplifier noise under ideal conditions will only lead to ideal specifications, not a measure of actual performance. Methods of S/N ratio measurement should be used that reflect the true performance instead of hollow specifications.

TABLE I. Summary of Electret Microphone Calculations

f Range (Hz)	25–50	50–100	100–200	200–400	400–800	800–1600	1600–3200	3200–6400	9600–12.8k	12.8k–20k
f Center (Hz)	37.5	75	150	300	600	1200	2400	4800	9600	16,400
f _{BW} (Hz)	25	50	100	200	400	800	1600	3200	6400	7,200
for R _L = 1GΩ										
Re(Z) (Ω)	74.2M	19.6M	4.98M	1.25M	0.31M	78k	19k	4.9k	1.22k	420
Z (Ω)	272M	140M	70.6M	35.4M	17.7M	8.8M	4.4M	2.2M	1.1M	650
e _{nz} (nV/√Hz)	1100	560	280	140	71	36	18	9	4.5	2.8
V _{nz} (μV)	5.5	3.96	2.8	1.98	1.42	1.02	0.72	0.51	0.36	0.24
V _{nz} ² (μV ²)	30.2	15.7	7.84	3.92	2.0	1.04	0.52	0.26	0.13	0.06
$(\Sigma V_{nz}^2)^{1/2} \approx 7.9 \mu V$										
R _L = 10GΩ										
Re(Z) (Ω)	8M	2M	0.5M	125k	31.3k	7.8k	2k	500	122	42
Z (Ω)	283M	141M	70.8M	35.4M	17.7M	8.8M	4.4M	2.2M	1.1M	650k
e _{nz} (nV/√Hz)	320	180	90	45	23	11.4	5.8	2.9	1.4	0.84
V _{nz} (μV)	1.6	1.3	0.9	0.64	0.46	0.32	0.232	0.16	0.112	0.07
V _{nz} ² (μV ²)	2.56	1.62	0.81	0.41	0.21	0.103	0.054	0.025	0.013	0.005
$(\Sigma V_{nz}^2)^{1/2} \approx 2.4 \mu V$										

TABLE II. Summary of Phono Cartridge Calculations

f Range (Hz)	25–50	50–100	100–200	200–400	400–800	800–1.6k	1.6k–3.2k	3.2k–6.4k	6.4k–12.8k	12.8k–20k
f Center (Hz)	37.5	75	150	300	600	1200	2400	4800	9600	16.4k
f _{BW} (Hz)	25	50	100	200	400	800	1600	3200	6400	7.2k
Q = (ωL _s /R _s)	0.156	0.313	0.625	1.25	2.5	5	10	20	40	68.4
Q ²	0.0244	0.098	0.391	1.56	6.25	25	100	400	1600	4678.6
1 + Q ²	1.0244	1.098	1.391	2.56	7.25	26	101	401	1601	4679.6
1 + Q ² /Q ²	42	11.24	3.56	1.64	1.16	1.04	1.01	1.0	1.0	1.0
R _p (Ω)	1.16k	1.24k	1.57k	2.9k	8.2k	29.4k	114k	454k	1.8M	5.29M
L _p (H)	31.5	8.43	2.67	1.23	0.87	0.78	0.76	0.75	0.75	0.75
R _p /R (Ω)	1.13k	1.21k	1.52k	2.74k	7k	18.1k	32.9k	42.6k	45.8k	46.6k
X _L (Ω)	7.42k	3.97k	2.52k	2.32k	3.28k	5.88k	11.45k	22.6k	45.2k	77.2k
X _C (Ω)	17M	8.48M	4.24M	2.12M	1.06M	0.53M	0.265M	0.133M	66.3k	38.8k
Re(Z) (Ω)	1.11k	1.11k	1.11k	1.15k	1.26k	1.73k	3.86k	12.4k	41.5k	34k
Z (Ω)	1.12k	1.15k	1.3k	1.77k	2.97k	5.59k	11.7k	24.4k	43.6k	40.1k
e _{nz} (nV/√Hz)	4.24	4.24	4.24	4.31	4.51	5.29	7.9	14.2	26	23.5
V _N (nV)	21.2	30	42.4	61	90.2	149.6	316	803	2080	1994
V _N ² (nV ²)	449.4	900	1798	3721	8136	22.4k	99.9k	645k	4.33M	3.98M
Δ ²	63.0	29.5	10.7	3.85	1.66	0.85	0.49	0.154	0.043	0.019
Δ ² V _N ² (nV ²)	28.3k	26.6k	19.2k	13.2k	13.5k	19k	48.9k	99.3k	186k	76k

$(\Sigma V_n^2)^{1/2} = 3 \mu V$ unequalized noise

$(\Sigma 1A_n 12V_n^2)^{1/2} = 0.73 \mu V$ RIAA equalized noise

REFERENCES

- [1] *Fraim, F. and Murphy, P., "Miniature Electret Microphones". J. Audio Eng. Society, Vol. 18, pp. 511-517. (Oct. 1970)*
- [2] *Hallgren, B. I., "On the Noise Performance of a Magnetic Phonograph Pickup". J. Audio Eng Society, Vol. 23, pp. 546-552. (Sep. 1976)*
- [3] *Fristoe, H.T., "The Use of Q Equations to Solve Complex Electrical Networks". Engineering Research Bulletin, Oklahoma State University, 1964.*
- [4] *Korn, G.A. and T.M., "Basic Tables in Electrical Engineering". McGraw-Hill, New York. New York, 1965.*
- [5] *Maxwell, J., "Hold Noise Down with JFETs". Electronic Design, Vol. 24, pp. 146-152. (Feb. 16. 1976).*

Author: John Maxwell, February 1977.

DISCLAIMER

FAIRCHILD SEMICONDUCTOR RESERVES THE RIGHT TO MAKE CHANGES WITHOUT FURTHER NOTICE TO ANY PRODUCTS HEREIN TO IMPROVE RELIABILITY, FUNCTION, OR DESIGN. FAIRCHILD DOES NOT ASSUME ANY LIABILITY ARISING OUT OF THE APPLICATION OR USE OF ANY PRODUCT OR CIRCUIT DESCRIBED HEREIN; NEITHER DOES IT CONVEY ANY LICENSE UNDER ITS PATENT RIGHTS, NOR THE RIGHTS OF OTHERS.

LIFE SUPPORT POLICY

FAIRCHILD'S PRODUCTS ARE NOT AUTHORIZED FOR USE AS CRITICAL COMPONENTS IN LIFE SUPPORT DEVICES OR SYSTEMS WITHOUT THE EXPRESS WRITTEN APPROVAL OF THE PRESIDENT OF FAIRCHILD SEMICONDUCTOR CORPORATION.

As used herein:

1. Life support devices or systems are devices or systems which, (a) are intended for surgical implant into the body, or (b) support or sustain life, or (c) whose failure to perform when properly used in accordance with instructions for use provided in the labeling, can be reasonably expected to result in significant injury to the user.
2. A critical component is any component of a life support device or system whose failure to perform can be reasonably expected to cause the failure of the life support device or system, or to affect its safety or effectiveness.

ON Semiconductor and  are trademarks of Semiconductor Components Industries, LLC dba ON Semiconductor or its subsidiaries in the United States and/or other countries. ON Semiconductor owns the rights to a number of patents, trademarks, copyrights, trade secrets, and other intellectual property. A listing of ON Semiconductor's product/patent coverage may be accessed at www.onsemi.com/site/pdf/Patent-Marking.pdf. ON Semiconductor reserves the right to make changes without further notice to any products herein. ON Semiconductor makes no warranty, representation or guarantee regarding the suitability of its products for any particular purpose, nor does ON Semiconductor assume any liability arising out of the application or use of any product or circuit, and specifically disclaims any and all liability, including without limitation special, consequential or incidental damages. Buyer is responsible for its products and applications using ON Semiconductor products, including compliance with all laws, regulations and safety requirements or standards, regardless of any support or applications information provided by ON Semiconductor. "Typical" parameters which may be provided in ON Semiconductor data sheets and/or specifications can and do vary in different applications and actual performance may vary over time. All operating parameters, including "Typicals" must be validated for each customer application by customer's technical experts. ON Semiconductor does not convey any license under its patent rights nor the rights of others. ON Semiconductor products are not designed, intended, or authorized for use as a critical component in life support systems or any FDA Class 3 medical devices or medical devices with a same or similar classification in a foreign jurisdiction or any devices intended for implantation in the human body. Should Buyer purchase or use ON Semiconductor products for any such unintended or unauthorized application, Buyer shall indemnify and hold ON Semiconductor and its officers, employees, subsidiaries, affiliates, and distributors harmless against all claims, costs, damages, and expenses, and reasonable attorney fees arising out of, directly or indirectly, any claim of personal injury or death associated with such unintended or unauthorized use, even if such claim alleges that ON Semiconductor was negligent regarding the design or manufacture of the part. ON Semiconductor is an Equal Opportunity/Affirmative Action Employer. This literature is subject to all applicable copyright laws and is not for resale in any manner.

PUBLICATION ORDERING INFORMATION

LITERATURE FULFILLMENT:

Literature Distribution Center for ON Semiconductor
19521 E. 32nd Pkwy, Aurora, Colorado 80011 USA
Phone: 303-675-2175 or 800-344-3860 Toll Free USA/Canada
Fax: 303-675-2176 or 800-344-3867 Toll Free USA/Canada
Email: orderlit@onsemi.com

N. American Technical Support: 800-282-9855 Toll Free
USA/Canada
Europe, Middle East and Africa Technical Support:
Phone: 421 33 790 2910
Japan Customer Focus Center
Phone: 81-3-5817-1050

ON Semiconductor Website: www.onsemi.com
Order Literature: <http://www.onsemi.com/orderlit>
For additional information, please contact your local
Sales Representative