

AX5051 Programming Manual



ON Semiconductor®

www.onsemi.com

OVERVIEW

AX5051 is a true single chip low-power CMOS transceiver primarily for use in SRD bands. The on-chip transceiver consists of a fully integrated RF front-end with modulator, and demodulator. Base band data processing is implemented in an advanced and flexible communication controller that enables user friendly communication via the SPI interface.

Connecting the AX5051 to a Micro-Controller

The AX5051 can easily be connected to any micro-controller. The micro-controller communicates with the AX5051 via a register file that is implemented in the AX5051 and that can be accessed serially via an industry standard Serial Peripheral Interface (SPI) protocol.

Reset can be performed via a dedicated signalling line or via the register file. Therefore, and due to an integrated power-on-reset (POR) block this signal is optional.

The AX5051 sends and receives data via the SPI port in frames. This standard operation mode is called frame mode.

In frame mode, the internal communication controller performs frame delimiting, and data is received and transmitted via a 4 level x 10 bit FIFO, accessible via the register file. Figure 1 shows the corresponding diagram. Connecting the interrupt line is highly recommended, though not strictly required.

APPLICATION NOTE

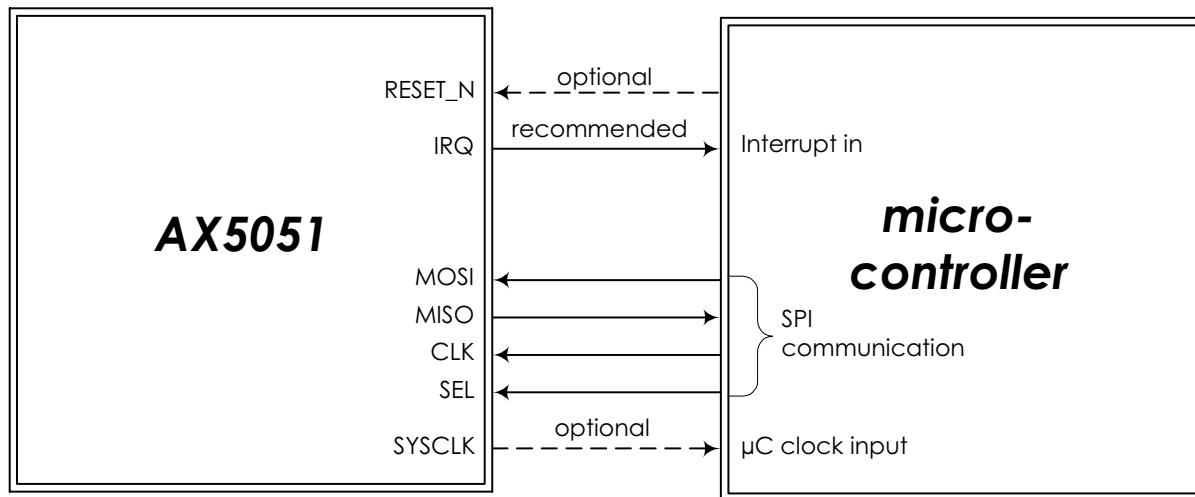

Figure 1. Connection Diagram with a micro-controller

AND9348/D

Pin Function Descriptions

Table 1. PIN FUNCTION DESCRIPTIONS

Symbol	Pin(s)	Type	Description
NC	1	N	Not to be connected
VDD	2	P	Power supply, must be supplied with regulated voltage VREG
GND	3	P	Ground
ANTP	4	A	Antenna input/output
ANTN	5	A	Antenna input/output
GND	6	P	Ground
VDD	7	P	Power supply, must be supplied with regulated voltage VREG
NC	8	N	Not to be connected
TST1	9	I	Must be connected to GND
TST2	10	I	Must be connected to GND
GND	11	P	Ground
RESET_N	12	I	Optional reset pin If this pin is not used it must be connected to VDD_IO
SYSCLK	13	I/O	Default functionality: Crystal oscillator (or divided) clock output Can be programmed to be used as a general purpose I/O pin
SEL	14	I	Serial peripheral interface select
CLK	15	I	Serial peripheral interface clock
MISO	16	O	Serial peripheral interface data output
MOSI	17	I	Serial peripheral interface data input
TST3	18	I	Must be connected to GND
IRQ	19	I/O	Default functionality: Transmit and receive interrupt Can be programmed to be used as a general purpose I/O pin
VDD_IO	20	P	Unregulated power supply
NC	21	N	Not connected
GND	22	P	Ground
NC	23	N	Not connected
VREG	24	P	Regulated output voltage VDD pins must be connected to this supply voltage A 1 μ F low ESR capacitor to GND must be connected to this pin
NC	25	N	Not to be connected
VDD	26	P	Power supply, must be supplied with regulated voltage VREG
CLK16P	27	A	Crystal oscillator input/output
CLK16N	28	A	Crystal oscillator input/output

A = analog signal
 I = digital input signal
 O = digital output signal
 I/O = digital input/output signal
 N = not to be connected
 P = power or ground

All digital inputs are Schmitt trigger inputs, digital input and output levels are LVCMOS/LVTTL compatible and 5 V tolerant. The center pad of the QFN28 package should be connected to GND.

AND9348/D

SPI Register Access

Registers are accessed via a synchronous Serial Peripheral Interface (SPI). Most registers are 8 bit wide and accessed using the waveforms detailed in Figure 2. These waveforms are compatible to most hardware SPI master controllers, and

can easily be generated in software. MISO changes on the falling edge of CLK, while MOSI is latched on the rising edge of CLK.

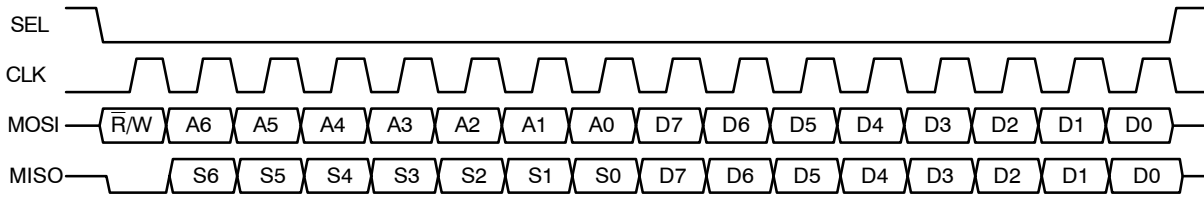

Figure 2. SPI 8 Bit Read/Write Access

It is necessary to deactivate and reactivate SEL between register accesses. Some registers perform preparatory actions on the falling edge of SEL and perform cleanup actions on the rising edge of SEL, so if SEL is left active between register accesses, some registers may fail.

Some device registers (TRKAMPL, TRKPHASE, TRKFREQ) are 16 bit registers that are continuously updated by the chip. These registers should not be accessed

by two individual 8 bit accesses, as both halves may be inconsistent if the chip updates the register between the two accesses.

The chip therefore supports atomic 16 bit register read accesses. Figure 3 shows the 16 bit read waveform if the address of the high byte is supplied, and Figure 4 shows the waveform if the address of the low byte is supplied.

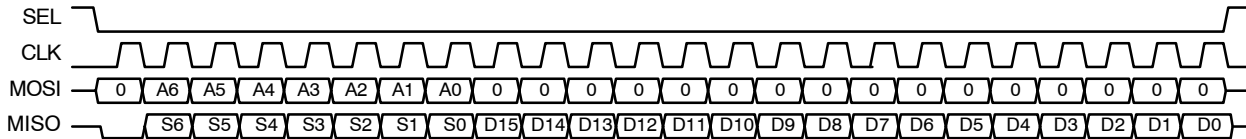

Figure 3. SPI 16 Bit Read Access, Most Significant Byte First

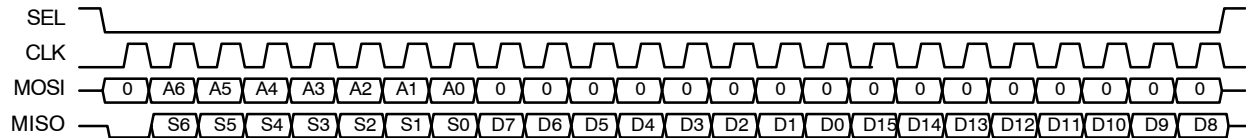

Figure 4. SPI 16 Bit Read Access, Least Significant Byte First

16 bit write accesses are not supported.

Status Bits

During the address phase of the access, the chip outputs the most important status bits. This feature is designed to speed up software decision on what to do in an interrupt handler. Table 2 shows which register bit is transmitted during the status timeslots.

For information on the meaning of the status bits see the Receive and Transmit section of the next chapter as well as the description of the register FIFOCTRL in the Register Description section.

Table 2. SPI STATUS BITS

SPI Bit Cell	Status	Register Bit
0	-	0
1	S6	PLL LOCK
2	S5	FIFO OVER
3	S4	FIFO UNDER
4	S3	FIFO FULL
5	S2	FIFO EMPTY
6	S1	FIFOSTAT(1)
7	S0	FIFOSTAT(0)

PROGRAMMING THE CHIP

The operation sequences of the chip can be controlled using the PWRMODE registers.

Table 3. PWRMODE REGISTER STATES

PWRMODE Register	Name	Description	Typical Idd
0000	POWERDOWN	All digital and analog functions, except the register file, are disabled. The core supply voltage is reduced to conserve leakage power. SPI registers are still accessible, but at a slower speed	0.5 μ A
0100	VREGON	All digital and analog functions, except the register file, are disabled. The core voltage, however is at its nominal value for operation, and all SPI registers are accessible at the maximum speed.	200 μ A
0101	STANDBY	The crystal oscillator is powered on; receiver and transmitter are off.	650 μ A
1000	SYNTHR _X	The synthesizer is running on the receive frequency. Transmitter and receiver are still off. This mode is used to let the synthesizer settle on the correct frequency for receive.	11 mA
1001	FULLR _X	Synthesizer and receiver are running	17 – 20 mA
1100	SYNTH _T TX	The synthesizer is running on the transmit frequency. Transmitter and receiver are still off. This mode is used to let the synthesizer settle on the correct frequency for transmit.	10 mA
1101	FULLT _X	Synthesizer and transmitter are running. Do not switch into this mode before the synthesizer has completely settled on the transmit frequency (in SYNTH _T TX mode), otherwise spurious spectral transmissions will occur.	11 – 50 mA

Figure 5 shows the basic programming flow chart of the device for transmitting, and Figure 6 for receiving.

1. Power Up Reference and Oscillators:

Set PWRMODE to STANDBY

First, the on-chip references and the crystal oscillator are powered up, but the synthesizer is still powered down. Settling time of this phase is dominated by the crystal oscillator start-up time, which depends on the specific crystal used but is typically 3 ms.

2. Program Parameters

Then the desired modulation, carrier frequency and encoding is set (see section “Parameter Programming”). This can be done while the crystal oscillator is settling.

3. Power Up Synthesizer:

Set PWRMODE to SYNTH_TTX (transmit mode) or to SYNTHR_X (receive mode)

After all the modulation parameters are set, the synthesizer can be powered up. The settling time of the synthesizer is 5 – 50 μ s depending on settings (see section AC Characteristics in the AX5051 Datasheet).

4. Auto-ranging

After powering up, the VCO in the synthesizer

needs to be auto-ranged to the correct range setting. This is done using the auto-ranging procedure, for details see section: Synthesizer VCO Auto-Ranging. The auto-ranging needs to be performed, if it has not been done in a previous RX/TX session, if the temperature or VDD have changed or if the frequency has changed.

5. Start transmitter/receiver:

Set PWRMODE to FULLT_X (transmit mode) or FULLR_X (receive mode)

6. Power down synthesizer:

Set PWRMODE to SYNTH_TTX (transmit mode) or SYNTHR_X (receive mode)

If the bit LOCURST in register LOCURST is set to 1 then the following applies: After FULLT_X mode it is mandatory to set to SYNTH_TTX, if this is omitted the device will not enter STANDBY or PWRDOWN correctly.

After FULLR_X mode switching to PWRDOWN directly is possible under all circumstances.

7. Power down:

Set PWRMODE to POWERDOWN When transmission or reception is finished, the chip can be powered down.

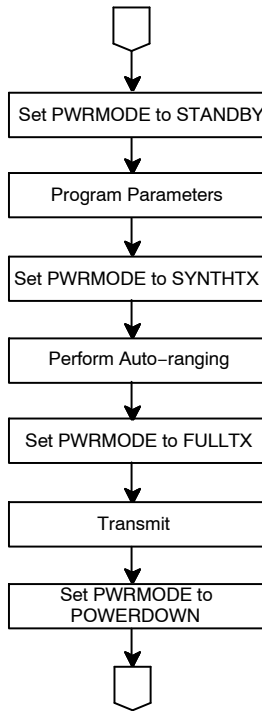

Figure 5. Transmit Flow Chart

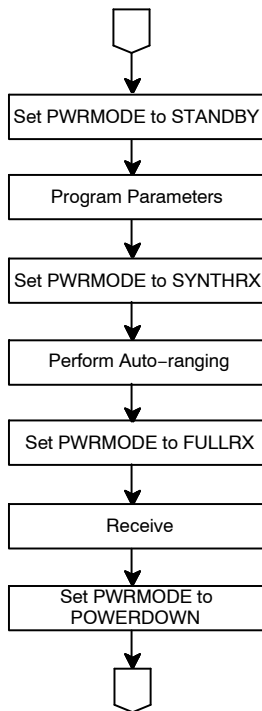

Figure 6. Receive Flow Chart

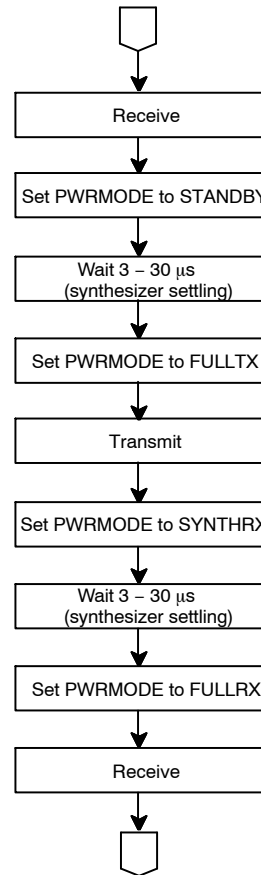

Figure 7. Receive Interrupted by Transmit Flow Chart

The register contents are preserved as long as the chip is powered, therefore, registers that do not change between receiving and transmitting do not need to be reprogrammed. Figure 7 shows the recommended sequence for transmitting packets during packet reception. This sequence avoids powering down the crystal oscillator and reference, thereby avoiding the start-up delays. The synthesizer VCO does not need to be re-auto-ranged, but, since this is not a zero IF receiver, the synthesizer needs 3–30 μ s to settle on the correct frequency. The value depends on the synthesizer settings, see section AC Characteristics in the AX5051 Datasheet.

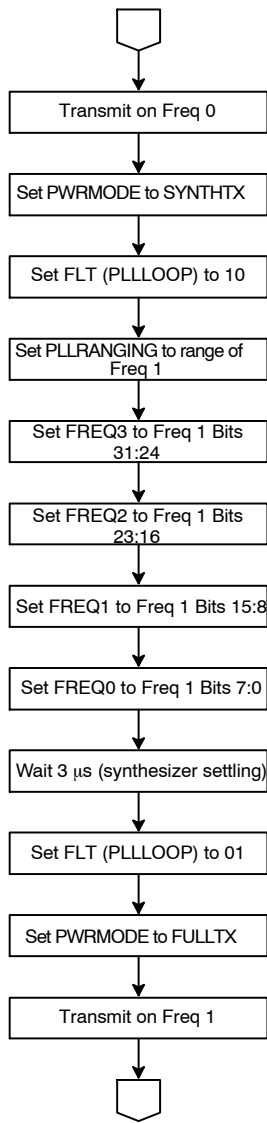

Figure 8. Transmit Frequency Change Flow Chart

In Frequency Hopping systems, it is important to perform fast frequency changes. Figure 9 shows the recommended frequency change flow chart for frequency hopping receivers, while Figure 8 shows the recommended frequency change flow chart for frequency hopping transmitters.

These flow charts detail the recommended sequence to change the transmit/receive frequency. They do not detail the synchronization necessary to keep transmitter and receiver hopping schedules synchronous.

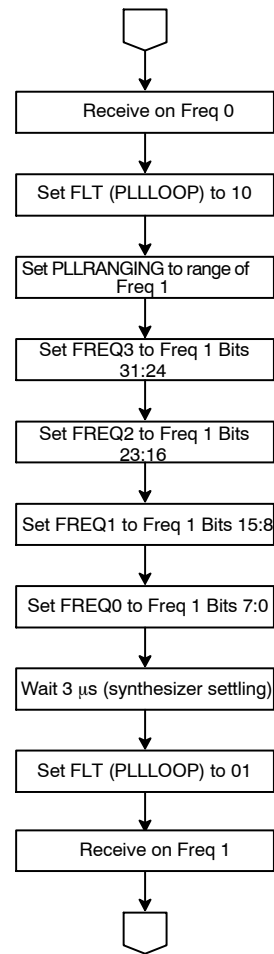

Figure 9. Receive Frequency Change Flow Chart

It is assumed that auto-ranging has been performed offline for all frequencies of the hopping schedule, and the auto-ranging results (VCOR bits of register PLLRANGING) have been stored in the micro-controller.

In the transmit case, the transmitter must be disabled before starting the frequency change and must only be re-enabled once the synthesizer has settled on the new frequency, in order to avoid spurious transmissions. In the receive case, this is not necessary, the receiver can be left running.

Parameter Programming

Choosing the Fundamental Communication Characteristics

Table 4 lists the fundamental communication characteristics that need to be chosen before the device can be programmed.

Table 4. FUNDAMENTAL COMMUNICATION CHARACTERISTICS

Parameter	Description
f_{XTAL}	Frequency of the connected crystal in Hz
modulation	FSK, MSK, ASK, PSK or OQPSK (for recommendations see Table 5 : Modulation trade-offs)
$f_{CARRIER}$	Carrier frequency (i.e. center frequency of the signal) in Hz
f_{IF}	Intermediate frequency in Hz, nominally 1 MHz
BITRATE	Desired bit rate, in bits/s
h	Modulation index, determines the frequency deviation for FSK $32 > h \geq 0.5$ for FSK, $f_{deviation} = 0.5 * h * BITRATE$ $h = 0.5$ for MSK and OQPSK $h = 0$ for all other modulations
TMGCORRRFAC	Determines the timing recovery speed and the preamble length required The relationship between TMGCORRRFAC and the preamble length and is $preamble\ length\ in\ bits = 3 * TMGCORRRFAC$, for details see section: Choosing the Preamble Duration Choose TMGCORRRFAC = 32 for best noise performance at the expense of long synchronization time Choose TMGCORRRFAC = 8 for faster synchronization time at the expense of noise performance Note that there is a lower bound for this value given in point 9 of section: Setting-up the Chip.
encoding	Inversion, differential, Manchester, scrambled, for recommendations see the description of the register ENCODING in the section: Overview and Table 30: Customary Telecom Modes Description.

Table 5 gives an overview of the trade-offs between the different modulations that AX5051 offers, they should be considered when making a choice.

Table 5. MODULATION TRADE-OFFS

Modulation	Trade-offs
ASK	For bit rates up to 600 kbit/s The sensitivity for equivalent peak output power is 3 dB lower than for the other modulation types, as the average transmit power is only half the maximum transmit power. It is recommended to use shaped ASK for data transmissions, as the spectral efficiency is greatly improved vs. non-shaped ASK. For receive operation there is no difference between shaped and non-shaped.
FSK	For bit rates up to 350 kbit/s Frequency deviation is a free parameter
MSK	For bit rates up to 350 kbit/s Robust and spectrally efficient form of FSK (Modulation is the same as FSK with $h = 0.5$) Frequency deviation given by bit rate The advantage of MSK over FSK is that it can be demodulated with higher sensitivity. Slightly longer pre-ambls required than for FSK
PSK	For bit rates up to 600 kbit/s. Bit rates blow 10 kbps are not recommended. Slightly longer pre-ambls required than for FSK It is recommended to use shaped PSK for data transmissions, as the spectral efficiency is greatly improved vs. non-shaped PSK. For receive operation there is no difference between shaped and non-shaped.
OQPSK	For bit rates up to 350 kbit/s Very similar to MSK, with added precoding/postdecoding For new designs, use MSK instead

Setting-up the Chip

The AX5051 should be programmed according to the following guide-line, for more detailed recommendations and descriptions see the corresponding register descriptions in the section Register Bank Description:

1. General set-up registers
 - Set bits IFMODE=0000 in register IFMODE
 - Set register PINCFG2 to 11000000
 - Set bits VCO_I=001 in register PLLVCOI
 - Set bits RXIMIX=01 in register RXMISC
 - These settings are mandatory for optimal performance of AX5051

For low power mode set bits REF_I=101 in register REF, for high sensitivity mode leave the bits at their default value REF_I=011

2. Program the PLLLOOP register
 - Bits FLT and PLLCPI must be set to program the synthesizer loop bandwidth. Recommended settings are given in Table 6. Bit BANDSEL is programmed to select the appropriate frequency band for $f_{carrier}$, set to 0 for 868/915 MHz band, set to 1 for 433 MHz band.

Table 6. RECOMMENDED SYNTHESIZER LOOP BANDWIDTH SETTINGS

Register Settings		Characteristics			Usage
FLT	PLLCPI	Loop Bandwidth	Start-up Time	RX/TX Switch Time	
01	010	100 kHz	25 μ s	15 μ s	Recommended setting for all modulations, all values of BITRATE, RX and TX Mandatory for FSK, MSK, OQPSK with BITRATE > 50 kHz
01	001	50 kHz	50 μ s	30 μ s	Use for TX if phase noise between 300 kHz and 1 MHz from carrier is critical Cannot be used for FSK, MSK, OQPSK with BITRATE > 50 kHz
11	010	200 kHz	12 μ s	7 μ s	Use to speed up start-up or switching Do not use for RX or TX
10	010	500 kHz	5 μ s	3 μ s	Use to speed up start-up or switching Do not use for TX

3. Program the frequency registers FREQ3, FREQ2, FREQ1 and FREQ0;
 - $FREQ = [f_{CARRIER}/f_{XTAL} \cdot 2^{24} + \frac{1}{2}]$
 - Ensure that the bit 0 of FREQ0 is set to one; this ensures that the built-in $\Delta\Sigma$ modulator does not exhibit tonal behaviour.
 - Note that to program frequencies in the 433 MHz band registers FREQ3, FREQ2, FREQ1, FREQ0 must be programmed to appropriate values and the bit BANDSEL in the PLLLOOP register must be set to 1.
4. Program the TXPWR register according to the desired output power
5. Program the IF frequency registers IFFREQHI and IFFREQLO
 - $IFFREQLO = [f_{IF}/f_{XTAL} \cdot 2^{17} + \frac{1}{2}]$
6. Program the frequency deviation registers FSKDEV2, FSKDEV1 and FSKDEV0;
 - $f_{DEVIATION} = h/2 \cdot BITRATE$
 - $FSKDEV = [f_{DEVIATION}/f_{XTAL} \cdot 2^{24} + \frac{1}{2}]$
7. Program the transmit bit rate registers TXRATEHI, TXRATEMID and TXRATELO;
 - $TXRATE = [BITRATE/f_{XTAL} \cdot 2^{24} + \frac{1}{2}]$
8. Program the receiver IF bandwidth registers CICDEC
 - $CICDEC = [(1.5 \cdot f_{XTAL})/(8 \cdot 1.2 \cdot BW)]$, if $TMGCORRRFRAC > 16$, or
 - $CICDEC = [(1.5 \cdot f_{XTAL})/(8 \cdot 1.4 \cdot BW)]$, if

$TMGCORRRFRAC \leq 16$,
with $BW = (1 + h) BITRATE$
Note that CICDEC must lie between $2 \leq CICDEC \leq 63$. If the above formulas result in a CICDEC less than 2, the chosen bandwidth is too high. Reduce the bit rate, or in the case of FSK, the modulation factor h. If the resulting CICDEC value is larger than 63, the chosen bandwidth is too narrow and not supported by the channel filter. Increase the bandwidth (set CICDEC to 63). The chip will work with $BW > (1+h) BITRATE$, at somewhat reduced sensitivity.

9. Determine the FSK over-sampling factor FSKMUL
 - For all modulations other than FSK, $FSKMUL = 1$.
 - For FSK, first, make sure that your choice of $TMGCORRRFRAC$ fulfils the following inequality: $TMGCORRRFRAC \geq f_{XTAL}/(4 \cdot BITRATE \cdot CICDEC)$
 - Then compute FSKMUL:

$$FSKMUL = \left[\frac{1}{\frac{4 \cdot BITRATE \cdot CICDEC}{f_{XTAL}} + \frac{1}{TMGCORRRFRAC}} \right]$$

10. Program the modulation register MODULATION
 - See Table 12 for the coding.
 - For FSKFSKMUL is used to set the appropriate

mode.

Note that for RX operation, there is no difference between shaped and non-shaped modulations.

- Program the receiver bit rate registers DATARATEHI and DATARATELO

$$\text{DATARATE} = \left\lceil \frac{2^{10} f_{\text{XTAL}}}{\text{BITRATE} \cdot \text{CICDEC} \cdot \text{FSKMUL}} + \frac{1}{2} \right\rceil$$

- Program the timing recovery dynamics registers TMGGAINHI and TMGGAINLO

$$\text{TMGGAIN} = \left\lceil \frac{\text{FSKMUL} \cdot \text{DATARATE}}{\text{TMGCORRRFRAC}} + \frac{1}{2} \right\rceil$$

DATARATE and TMGGAIN must fulfil the following inequality in order to function correctly: $\text{DATARATE} \geq \text{TMGGAIN} + 2^{12}$

The bandwidth computation in point 8 above and the condition on TMGCORRRFRAC in point 9 above ensure that this inequality holds.

- Program the tracking loop dynamics registers PHASEGAIN, FREQGAIN, FREQGAIN2 and AMPLGAIN according to Table 7:

Table 7. TRACKING LOOP DYNAMICS REGISTER VALUES

Modulation	PHASEGAIN [3:0]	FREQGAIN [3:0]	FREQGAIN2 [3:0]	AMPLGAIN [3:0]
ASK	0	6	6	6
PSK, MSK, OQPSK	3	6	6	6
FSK	3	3	6	6

- Program the AGC dynamics registers AGCATTACK and AGCDECAY according to Table 8.

Table 8. AGC DYNAMICS REGISTER VALUES

Modulation	Register	Recommended Setting
ASK	AGCATTACK	$\text{AGCATTACK} = 27 + \lceil \log_2 (\text{BITRATE}/(10 \cdot f_{\text{XTAL}})) \rceil$
ASK	AGCDECAY	$\text{AGCDECAY} = 27 + \lceil \log_2 (\text{BITRATE}/(100 \cdot f_{\text{XTAL}})) \rceil$
FSK, MSK, (OQ)PSK	AGCATTACK	$\text{AGCATTACK} = 27 + \lceil \log_2 (\text{BITRATE}/f_{\text{XTAL}}) \rceil$
FSK, MSK, (OQ)PSK	AGCDECAY	$\text{AGCDECAY} = 27 + \lceil \log_2 (\text{BITRATE}/(10 \cdot f_{\text{XTAL}})) \rceil$

- Program the ENCODING register according to the desired bit encoding
- Program the FRAMING register according to the desired framing mode
- Program the PINCFG1, PINCFG2, PINCFG3 according to the desired pin usage
NOTE: Care must be taken to keep the reserved bits PINCFG1 [7:6] at their default value of 11 and the bit PINCFG2[4] at its default value of 0, as well as writing the bits TST_PINS[1:0] to 11 in register PINCFG2, if this is not done, then large currents may flow through the device pins TST1, TST2 OR TST3.

Synthesizer VCO Auto-Ranging

Whenever the frequency or the environment (e.g. temperature, voltage) of the chip changes, the synthesizer VCO should be set to the correct range using the built-in auto-ranging. A re-ranging of the VCO is required if the frequency change required is larger than 5 MHz in the 868/915 MHz band or 2.5 MHz in the 433 MHz band.

Figure 10 shows the flow chart of the auto-ranging process.

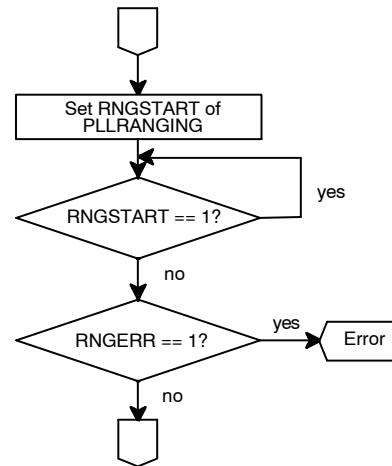

Figure 10. Synthesizer VCO Auto-Ranging Flow Chart

Before starting the auto-ranging, the frequency registers (FREQ3, FREQ2, FREQ1 and FREQ0) need to be programmed, and the chip should be in SYNTHRX or SYNTHTX mode.

Auto-ranging starts at the VCOR (register PLLRANGING) setting; if you already know the approximately correct synthesizer VCO range, you should set VCOR to this value prior to starting auto-ranging; this can speed up the ranging process considerably. If you have no prior knowledge about the correct range, set VCOR to 8. Starting with VCOR < 6 should be avoided, as the initial synthesizer frequency can exceed the maximum frequency specification.

Hardware clears the RNG_START bit automatically as soon as the ranging is finished; the device may be programmed to deliver an interrupt on resetting of the RNG_START bit.

AFC

Commercial Crystals only have a limited accuracy. Furthermore, since the crystal runs at a fraction of the RF carrier frequency, any crystal frequency offset is multiplied by the synthesizer by approximately a factor of 25 or 50, depending on the RF frequency band. While the receiver does have automatic frequency tracking, it can only track transmit signals that fall within its digital channel pass-band. It is therefore important to transmit and receive on the correct frequency. The smaller the bit rate, the higher the accuracy requirements for the reference crystal.

There are three primary methods to deal with frequency offset:

- Frequency Tracking
- Frequency Acquisition
- Factory Calibration

Frequency Tracking is normally automatically performed by the chip.

Whenever the frequency uncertainties are larger than the maximum tracking range of the frequency tracking logic, Frequency Acquisition and/or Factory Calibration may be used to augment Frequency Tracking.

As an example, consider a 433 MHz communication system utilizing a 16 MHz reference frequency with ± 10 ppm frequency uncertainty. This translates into a RF carrier frequency uncertainty of 4.33 kHz. Since both the receiver and the transmitter will exhibit this uncertainty, the maximum frequency offset is ± 8.66 kHz. For bit rates ≥ 40 kbit/s, the built in frequency tracking circuit is enough (the following section lists the maximum frequency offsets for frequency tracking). For bit rates down to about 5 kbit/s, FSK with large h may be used, at the expense of a worse BER performance, to avoid having to use additional means for frequency acquisition. For lower bit rates, or ASK/PSK modulation with bit rates less than 40 kbit/s, Frequency Acquisition, Factory Calibration or a better reference frequency must be used in addition to Frequency Tracking.

Frequency Tracking

The receiver contains circuitry to compensate for transmitter frequency offsets. This circuitry is fully automatic. The current frequency offset can be read out from

the TRKFREQHI, TRKFREQLO registers. These registers are valid whenever the receiver is locked to a transmit signal.

The frequency tracking circuitry can compensate offsets up to approximately $\pm 1/4$ VBITRATE in PSK mode. In FSK mode, the frequency tracking circuitry can compensate for the offset of all signals that fit within the chosen digital channel filter bandwidth (see programming of CICDEC register). Thus, by artificially choosing a wider digital channel filter bandwidth, the tracking range can be enlarged at the expense of a lower noise performance. In ASK mode, the frequency tracking circuitry is not used, the received signal must simply pass the receiver filter.

The frequency tracking logic can also be used to compensate for environmental conditions and crystal aging. To do this, the receiver should monitor frequency offsets over long timeframes. To make sure that a valid transmit signal is present, the receiver should read the tracking registers (TRKFREQHI, TRKFREQLO) immediately after receiving a correct packet. If the observed frequency is consistently off the expected frequency over a longer timeframe, the micro-controller can assume that its crystal has drifted off and should compensate for the frequency change. Compensation should be performed by changing the frequency registers (FREQ3, FREQ2, FREQ1 and FREQ0) accordingly.

The exact algorithm for the frequency compensation varies widely with MAC protocol and other system considerations, but the following guidelines are recommended:

- In a peer-to-peer scenario with two stations, both stations should adjust only their receive frequency, to avoid instability of the whole system.
- In a master-slave system with higher quality masters, only the slaves should adjust both their receive and transmit frequencies.

Frequency Acquisition

Frequency Acquisition makes use of the on-chip Frequency Tracking hardware with progressively narrower bandwidths to widen the range of initial frequency offsets that can be dealt with.

One side transmits a long preamble (or even just an unmodulated carrier), during which the other side measures the frequency of this transmit signal. This frequency acquisition step can be performed during system setup, upon user interaction, or before each transmission.

On the receiver side, the frequency tracking circuit is used to measure the signal frequency. This is possible because the frequency tracking circuit works at approximately 10 dB lower signal levels than where data reception is possible. So the receiver should perform the following actions:

1. Set the receiver to FSK, bandwidth approximately 10 times the modulation bandwidth. FSK should be used during acquisition irrespective of the data transmission modulation. Also, DATARATE should be set to 0x1000, which results in a datarate

being tied to the filter bandwidth, and having no relationship to the actual transmission data rate. Furthermore, TMGGAIN should be set to 0 to disable timing acquisition.

2. Wait until TRKFREQHI, TRKFREQLO is settled (see section: Preamble for the time required for TRKFREQHI, TRKFREQLO settling)
3. Read TRKFREQHI, TRKFREQLO, and compute the offset that needs to be applied to FREQ3, FREQ2, FREQ1, FREQ0
4. Repeat steps 1–3 with approximately 3 times the modulation bandwidth
5. Set the receiver to the modulation parameters, and start receiving
6. Check the received data for plausibility– start over if only garbage is received, as there may not have been a carrier transmitted during acquisition.

The AX5051–RNG Range Evaluation Kit contains example software to perform Frequency Acquisition.

Factory Calibration

Depending on the desired bit rate and the manufacturing tolerances of the chosen crystal, it may be necessary to calibrate the crystal frequency during production.

In order to be able to calibrate the crystal, one needs to measure its frequency. The recommended method to measure its frequency is to use the SYSCLK pin, which can be programmed to output the crystal clock frequency (or a fraction of it). Directly probing the CLK16P or CLK16N pins is not recommended, as the load capacitance of the measuring equipment will change the frequency of the crystal. Also make sure that identical values for registers XTALCAP and XTALOSC are being used during measurement and normal operation, as these register settings may slightly affect the crystal oscillator frequency.

An alternative method to measure the actual crystal frequency is to transmit an RF signal on a nominal frequency, and then measure the deviation of the actual transmit signal frequency from the nominal one with an RF counter. Measurements with a spectrum analyzer are generally not accurate enough.

Once the actual crystal frequency is known, it is recommended to correct for the crystal frequency deviation by changing the frequency registers (FREQ3, FREQ2, FREQ1 and FREQ0) accordingly.

An alternative method to correct for crystal frequency deviation is to change the register XTALCAP. This method however is inferior in resolution to the frequency register method.

Receive and Transmit

During receive and transmit, the software communicates with the receiver and the transmitter through a 10 bit wide and 4 levels deep FIFO. Figure 11 shows the FIFO write process and Figure 12 shows the FIFO read process.

FIFO full, empty, overrun and underrun flags are also transmitted during the status phase of SPI transfers. See section: SPI Register Access and Table 2: SPI Status Bits for details. FIFO flags may also be used to generate interrupts.

The AX5051 can also be programmed to automatically stop the receiver on FIFO overrun and to stop the transmitter on FIFO underrun.

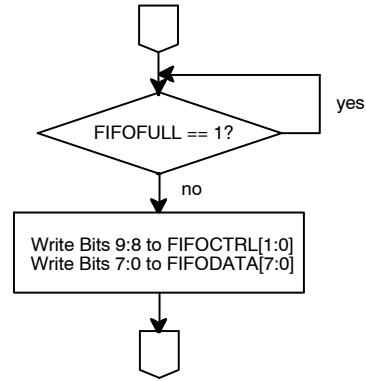

Figure 11. Write FIFO Flow Chart

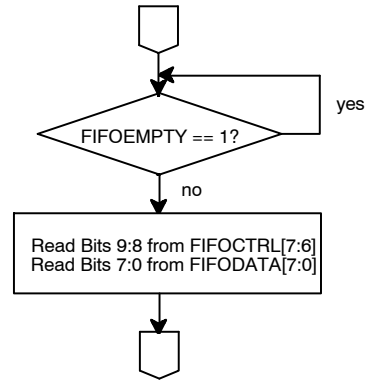

Figure 12. Read FIFO Flow Chart

Bits[7:0] are data information in both read and write. During a write access to the FIFO, Bits 9 and 8 hold the FIFOCMD[1:0] bits of the FIFOCMD register. During a read access to the FIFO, Bits 9 and 8 are read from FIFOCMD[1:0] of the FIFOCMD register bits[7:6]. The function of these bits depends on the framing mode (for more information see following sections). The device offers two different framing modes, namely HDLC and 802.15.4 (ZigBee). Additionally, Raw Mode and Raw Mode with Preamble Match allow the implementation of legacy protocols in software. FIFO operation differs slightly depending on the framing mode.

Write Access:

Bits 9 and 8 hold the bits FIFOCMD [1:0] of the FIFOCTRL register during a write access to the FIFO.

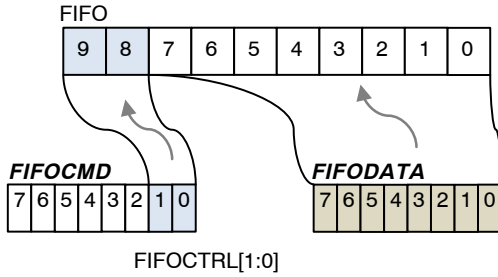

Figure 13.

Read Access:

During a read access to the FIFO Bits 9 and 8 are read from FIFOSTAT[1:0] of the FIFOCTRL register Bits[7:6].

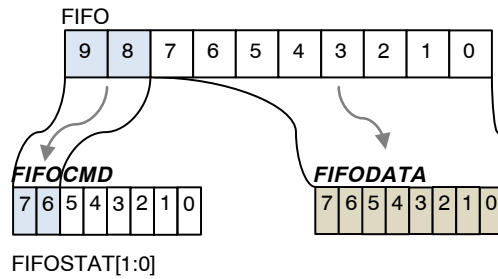

Figure 14.

Table 9. HDLC MODE BITS

Bit [9:8]	Transmit FIFOCTRL[1:0]	Receive FIFOSTAT[1:0]
00	Data Byte (bit stuffed)	Data Byte
01	CRC Byte	Packet End (Data holds status information) Packet End is also an indication for Packet Start Status Information Bit[3] = 1: CRC ok Bit[2:0] = 110: full byte transfers only
10	Not used	Abort detected
11	RAW Byte (not bit-stuffing, CRC is initialized) Used for flags (e.g. EOF)	Abort detected

In transmit the bits [9:8] describe the type of data in the FIFODATA[7:0] to be transmitted. This controls the internal framing block and enables or disables bit stuffing for data or flags, respectively. It also initiates CRC calculation. However the flag content and the CRC bytes have to be written by the host processor according to the sequence shown in Figure 15. The number of CRC bytes has to be chosen according to the type of CRC chosen in the FRAMING register (16 bit or 32 bit). For CRC insertion it

HDLC

In HDLC mode, frames start and end with the bit pattern 01111110.

HDLC uses bit-stuffing: In order to ensure that no bit pattern inside the frame can be erroneously detected as a frame end, the transmitter inserts a 0 bit after five consecutive one bits; the receiver automatically removes those inserted 0 bits, making the process transparent to the user.

At the end of a HDLC frame, a checksum is transmitted. Seven or more consecutive one bits are treated as an ABORT, causing the current packet to be discarded. See [4] for a more elaborate description of HDLC.

In HDLC mode the meaning of the additional 2 bits in the 10 bit FIFO describe the content of FIFODATA[7:0]:

does not matter what is written in the CRC bytes, as the chip will calculate the CRC value and will change the values.

In receive the bits [9:8] describe the type of data received. If an end of packet delimiter flag is detected, the chip automatically evaluates the CRC and sets the bits [3:0] of the data in the flag to signal the result of the CRC.

Figure 16 shows the HDLC transmit process, while Figure 17 shows the HDLC receive process.

AND9348/D

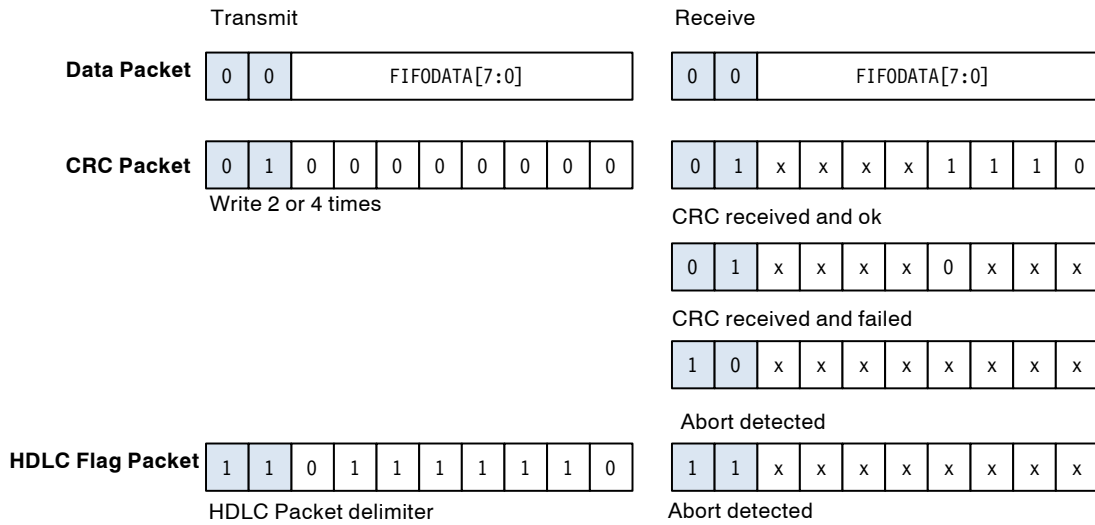

Figure 15.

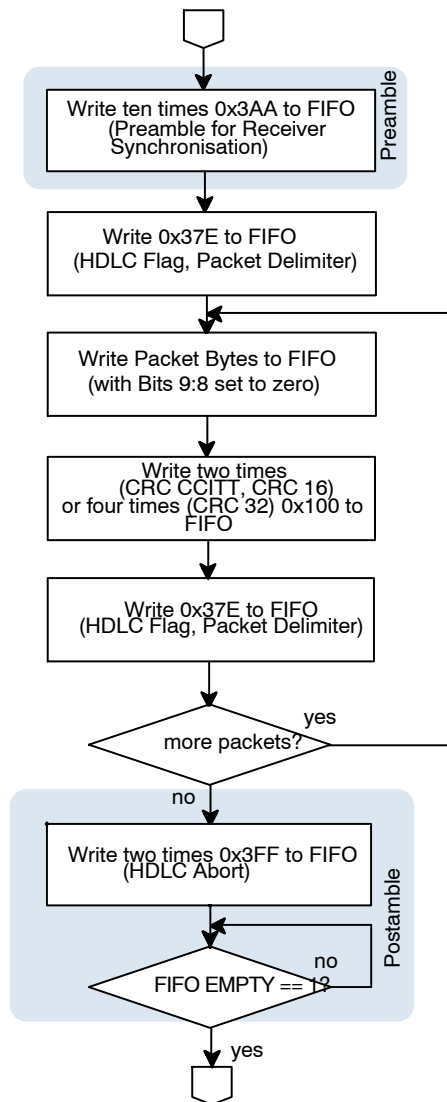

Figure 16. HDLC Transmit Flow Chart

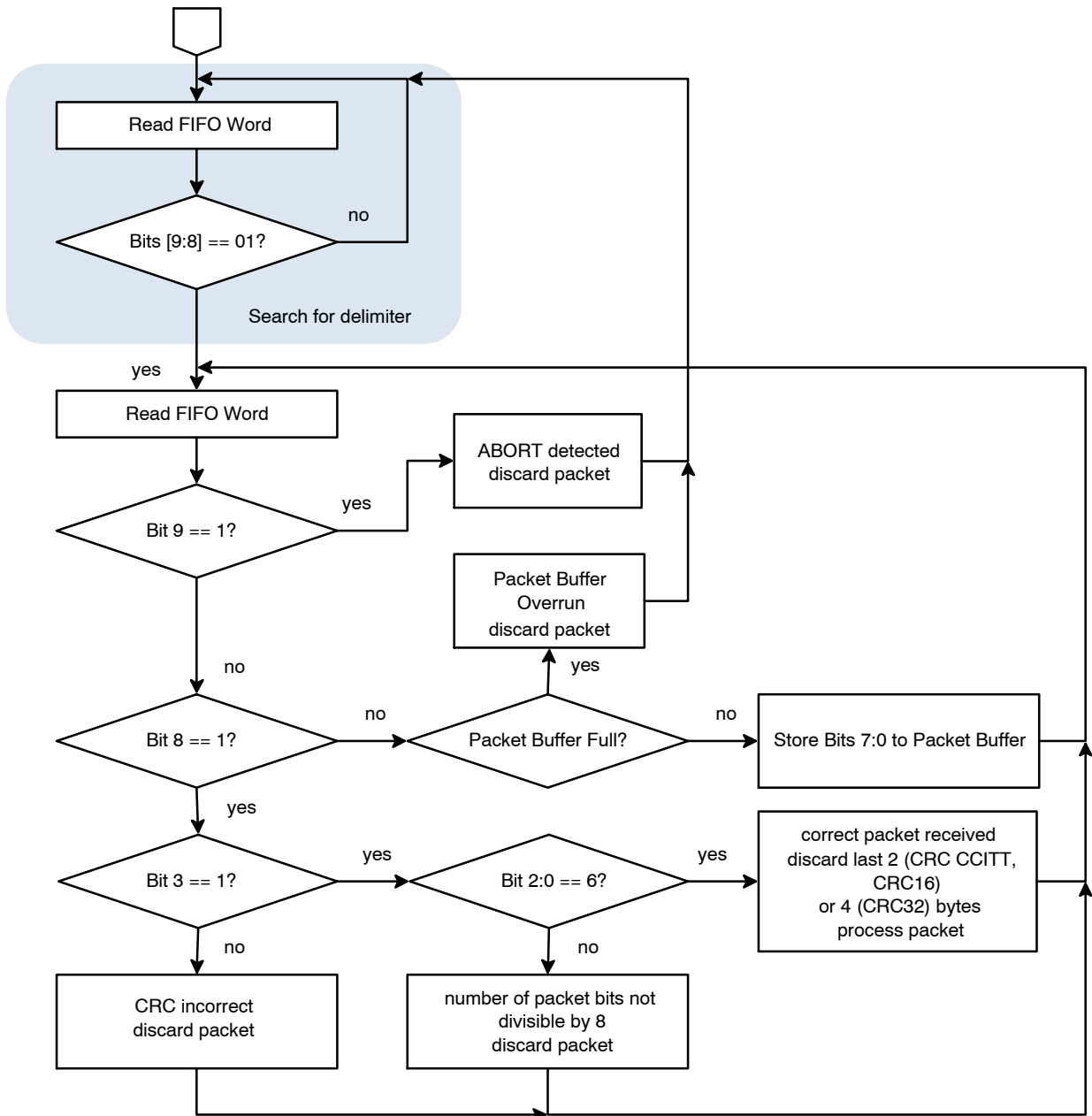

Figure 17. HDLC Receive Flow Chart

802.15.4 (ZigBee)

Receiver and transmitter operation differs slightly in 802.15.4 mode versus HDLC mode, due to IEEE 802.15.4 not having a PHY CRC, and 802.15.4 determining packet length from the first byte transmitted. See [3] for a description of the 802.15.4 PHY.

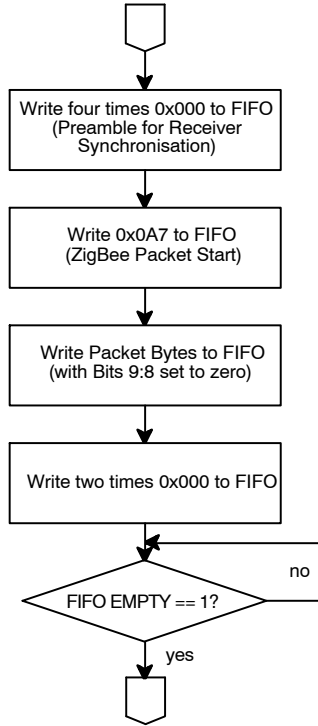

Figure 18. 802.15.4 Transmit Flow Chart

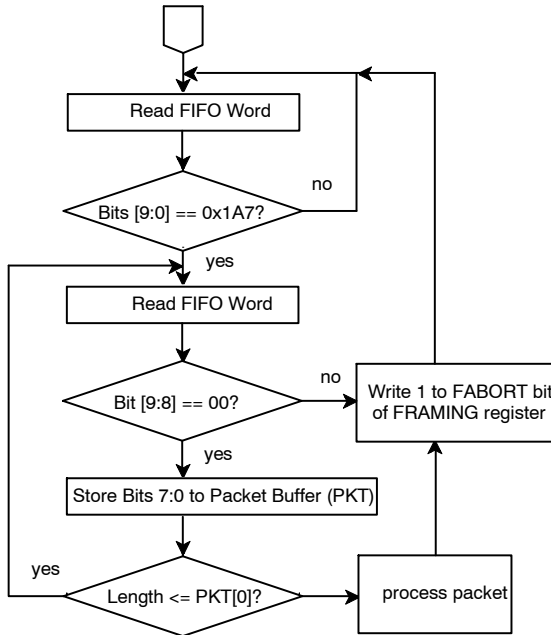

Figure 19. 802.15.4 Receive Flow Chart

Figure 18 details the 802.15.4 transmit operation, while Figure 19 details the 802.15.4 receive operation.

Raw Mode

In Raw Mode, no framing is performed. Received bits are grouped into 8 bit bytes and stored in the FIFO. Transmit bits are retrieved from the FIFO as 8 bit bytes and then serialized. The bits are received and transmitted LSB first, that means that bit 0 was received first or will be transmitted first. No byte synchronisation is performed.

Raw mode is useful to implement legacy protocols in software on the micro-controller.

Raw Soft-Decision Mode

In Raw Soft-Decision Mode, no framing is performed. During receive, for each received bit, a 10-bit signed value is written into the FIFO. The sign of the value determines the received bit value, and the magnitude indicates the likelihood of the value being correct.

This mode can be used to improve the performance of error correcting codes implemented in software on the micro-controller.

Transmission works exactly the same as in Raw Mode.

Raw Mode with Preamble Match

Raw Mode with Preamble Match works the same as Raw Mode. Additionally, the receiver only starts receiving after the received bit stream matches a programmable preamble. The preamble length is also programmable between 4 and 32 in multiples of 4. The preamble is stored in the CRCINIT3, CRCINIT2, CRCINIT1, CRCINIT0 registers, the length is programmed via the bits MATCHLEN[3:0] in the register FRAMING.

During transmission, no special preamble handling is performed by the AX5051. The preamble needs to be transmitted in software.

Interrupts

The AX5051 supports interrupts for all non-immediate actions. Interrupts, while not strictly necessary, allow the micro-controller to perform other tasks instead of waiting for the AX5051.

The AX5051 supports level triggered interrupts.

Figure 19 shows the interrupt logic. The AX5051 supports 6 interrupt sources. Each source may be individually inverted and masked. The final interrupt pin may also be inverted, to support both level active high and level active low interrupts. Table 10 lists all interrupt sources, and how they can be cleared.

Registers used for interrupt configuration programming are IRQMASK, IRQREQUEST and IRQINVERSION.

AND9348/D

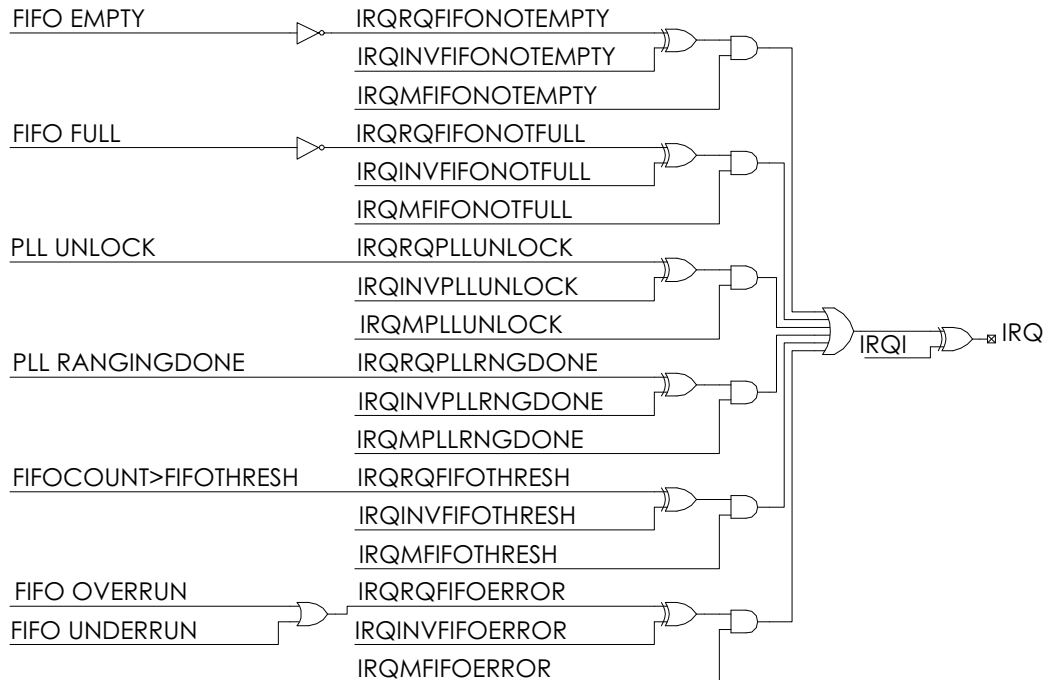

Figure 20. Interrupt Logic Diagram

Table 10. INTERRUPT SOURCES

Source	When Active	How to Clear
FIFO Not Full	The FIFO contains less than 4 words. At least one word can be written without causing an overrun.	Write words into the FIFO until it is full. Be careful not to cause overruns.
FIFO Not Empty	The FIFO contains at least one word. At least one word can be read without causing an underrun.	Read words from the FIFO until it is empty. Be careful not to cause underruns.
PLL Unlock	The PLL has lost lock	This interrupt can be cleared by reading the PLLRANGING register. After switching the synthesizer on, and after frequency changes (including receive ↔ transmit switches), the synthesizer requires some time to settle on the correct frequency and to achieve phase lock with the reference crystal. After that, it should remain locked. The synthesizer losing lock after that point indicates a severe problem. Check the following: <ul style="list-style-type: none"> • Synthesizer programming (esp. frequency, loop filter settings, charge pump settings, VCO settings) are correct • Synthesizer VCO has been auto-ranged properly • VDD is within spec and not too noisy • Temperature is within spec • Synthesizer is enabled
PLL Ranging Done	The synthesizer has finished auto-ranging its VCO	PLL Ranging Done can be cleared only by restarting a new auto-ranging process. If no more ranging processes are needed, mask the interrupt.
FIFO Threshold	The FIFO contains more words than FIFOTHRESH, i. e. FIFOCOUNT > FIFOTHRESH	This interrupt can be cleared by writing words into the FIFO until FIFOCOUNT > FIFOTHRESH, or by writing a value greater than or equal to FIFOCOUNT into the FIFOTHRESH register.
FIFO Error	A FIFO overrun or underrun has occurred	This interrupt is cleared as soon as the FIFO OVER and FIFO UNDER bits in the FIFOCTRL register are cleared, i.e. by reading the FIFOCTRL register.

Edge triggered interrupts are not directly supported. In the unlikely event that the chosen micro-controller does not support level triggered interrupts and only supports edge triggered interrupts, they need to be emulated in software. The following C pseudo code illustrates how this can be done:

```
void interrupt_handler(void)
{
    acknowledge_interrupt();
    do {
        handle_interrupt();
    } while (IRQ);
}
```

The first line, `acknowledge_interrupt()`, acknowledges the interrupt in the interrupt controller of the micro-controller. How this is done is specific to the micro-controller in question, and may even be implicit. The following loop handles interrupts as long as the IRQ line is still active. It is important that the interrupt handler is not terminated before IRQ goes inactive, because otherwise no new edges will be produced by the AX5051, and the interrupt becomes stuck.

Interrupt Strategies

The AX5051 supports three interrupt strategies:

1. The default strategy is to assert IRQ as soon as there is one word in the FIFO (receive, using the FIFONOTEMPTY interrupt) or there is one word empty space in the FIFO (transmit, using the FIFONOTFULL interrupt). The micro-controller is required to service the interrupt within 24 bit times (24/BITRATE) to prevent a FIFO overrun or underrun. The micro-controller will receive one interrupt per received FIFO word (message byte). This strategy is recommended for micro-controllers with low interrupt overhead (which is true for most micro-controllers).
2. The second strategy is to assert IRQ only when absolutely necessary, i.e. when the FIFO is full (receive, using the inverted FIFONOTEMPTY interrupt) or when the FIFO is empty (transmit, using the inverted FIFONOTEMPTY interrupt). The micro-controller will receive one interrupt every three FIFO words (message bytes). This strategy is useful for micro-controllers with a very high interrupt overhead. Care must be taken to avoid FIFO overruns and underruns.
3. The FIFOTHRESH interrupt allows an arbitrary trade-off between interrupt rate and interrupt service latency.

Preamble

At the beginning of a data transfer, a preamble must be transmitted, before the actual data can be transmitted. The preamble has many purposes:

- The preamble allows the power amplifier to ramp up to operational power levels. This is not an issue with the built-in amplifier of the AX5051, which is nearly instantaneous, but may be an issue if external amplifiers are used.
- The preamble allows the receiver to achieve lock
- The preamble allows the encoder (transmitter) and the decoder (receiver) to initialise

The AX5042/AX5051 Preamble Calculator [5] summarizes the rest of this chapter and allows to calculate recommended preamble lengths.

Choosing the Preamble Bit Pattern

In 802.15.4, the preamble bit pattern is specified by the standards committee. This specification, which is four bytes of 0x00, should be followed.

In all other modes, the preamble bit pattern as it enters the modulator should be chosen such that:

- It is DC-free, to ensure that frequency offset estimation works correctly
- It contains as many transitions as possible

Now the transmitter cannot directly control the modulator bits, only the bits that enter the encoder. Thus, the bytes transmitted during the preamble should be chosen according to the selected encoder mode:

Table 11. RECOMMENDED PREAMBLE VALUES

Encoder Settings	Preamble Byte
INV = X, DIFF = 0, SCRAM = 0, MANCH = 0	0x55 or 0xAA
INV = 0, DIFF = 1, SCRAM = 0, MANCH = 0	0xFF
INV = 1, DIFF = 1, SCRAM = 0, MANCH = 0	0x00
INV = X, DIFF = X, SCRAM = 1, MANCH = X	0x55 or 0xAA.
INV = X, DIFF = 0, SCRAM = 0, MANCH = 1	0x00 or 0xFF
INV = 0, DIFF = 1, SCRAM = 0, MANCH = 1	0x00
INV = 1, DIFF = 1, SCRAM = 0, MANCH = 1	0xFF

Choosing the Preamble Duration

A recommended choice for the preamble duration for FSK is 32 bytes (TMGCORRRFRAC = 32) for full frequency offset compensation capabilities. The receiver can work with preambles as short as 3 byte, TMGCORRRFRAC must be set to 8 accordingly. With a 3 byte preamble it may not be possible to reach optimal sensitivities and to correct for the full frequency offset range. All sensitivities quoted in the AX5051 Data Sheet refer to TMGCORRRFRAC = 32 and a preamble length long enough to correct for the full frequency offset range.

The following section gives some details for a more complete understanding of the factors affecting the preamble duration choice:

The preamble duration should be chosen to be the sum of the following components, rounded up the next higher integral number of bytes (numbers below are given in bits).

- Power amplifier startup time. Zero for the built-in amplifier of the AX5051. Consult documentation in case an external amplifier is used.
- The decoder needs 18–19 bits to synchronize the descrambler, if the descrambler is used, otherwise 1–2 bits
- The time the receiver needs to achieve bit lock is a probabilistic process, and depends on the bit recovery speed settings, the frequency of transitions in the transmit signal, as well as on the signal-to-noise ratio of the received signal. A reasonable estimate would be $3VTMGCORRRFRAC$ if the preamble values detailed above are used and the scrambler is disabled, or $4VTMGCORRRFRAC$ if the scrambler is used.
- The time the receiver needs to achieve frequency offset and phase lock is again a probabilistic process that depends on the initial frequency offset, the signal-to-noise ratio of the received signal, the modulation, and the bandwidth (speed) setting of the frequency recovery loop.
 - ◆ ASK: For ASK, achieving frequency lock is not required for demodulation, so no additional preamble for achieving frequency lock needs to be used TRKFREQ is valid after approximately 600–800 bits.
 - ◆ FSK: FSK frequency lock is achieved within 150 bits with FREQGAIN = 3 for the full supported

frequency offset range ($\pm\frac{1}{2} \text{ BITRATE} \cdot \text{FSKMUL}$). Frequency lock time is approximately proportional to the frequency offset, so if the frequency offset can be guaranteed to be lower than the maximum supported range, correspondingly shorter preambles can be used. Setting FREQGAIN = 2 halves the number of bits required for frequency lock at the expense of a slightly worse BER performance (< 1dB). For small h ($h \leq 1$), FREQGAIN = 1 or FREQGAIN = 0 can be used to further shorten the required number of preamble bits, at the expense of a larger BER performance penalty.

- ◆ For very large h ($h \geq 16$), it is recommended to turn off frequency acquisition completely by setting FREQGAIN and FREQGAIN2 to 0x0F. The large frequency deviation ensures a corresponding frequency offset tolerance, and switching on the frequency acquisition circuitry would result in it trying to remove part of the modulation, causing BER degradation or long acquisition times.
- ◆ PSK: PSK frequency lock is required for demodulation, and is achieved within 140 bits over the full supported offset range ($\pm\frac{1}{4} \cdot \text{BITRATE}$). Guaranteeing lower frequency offset does not shorten the required preamble. Additional time may be needed to ensure lock at the correct offset, see the next section for more information.

PSK Frequency Lock

PSK transmits information bits by using a carrier phase angle of 0 or π . The transmit waveform is therefore periodic. The frequency tracking circuit can therefore lock at either the correct offset, or the correct offset $\pm\frac{1}{2} \cdot \text{DATARATE}$. In the latter case, every second bit at the input of the decoder will be inverted, because the receiver applies an additional π rotation per received bit. Differential encoding is usually used together with PSK, so after differential decoding, the bitstream will look inverted if the frequency acquisition circuitry is locked to the correct offset $\pm\frac{1}{2} \cdot \text{DATARATE}$.

In order to prevent false lock of the frequency acquisition, the microcontroller should periodically check whether the current frequency offset is outside the range $-\frac{1}{4} \text{ DATARATE} \dots +\frac{1}{4} \text{ DATARATE}$, and restart frequency acquisition if this is the case.

AND9348/D

The following C code fragment performs this task and should be called periodically:

```
if (abs((int8_t)spi_read(TRKFREQHI)) >= 0x40) {  
    spi_write(TRKFREQHI, 0xC0);  
}
```

Furthermore, the preamble duration should be prolonged by the periodicity of executing this code fragment, to ensure that the receiver is fully synchronized before packet data is transmitted.

For example, if 100 kbit/s PSK is used and this fragment is executed once per millisecond (ms), the preamble should be prolonged by 1ms or 100 bits.

Postamble

After the data is transmitted, the micro-controller must write two additional postamble bytes to the FIFO. These bytes are used to clear the transmit pipeline. Their contents do not matter; HDLC flags can be used in HDLC mode.

After these preamble bytes are written to the FIFO, the micro-controller must wait until the FIFO is fully drained (empty). Only then can the transmitter be turned off.

RSSI

A first order approximation of the received signal strength (RSSI) is

$$\text{RSSI1} = -\text{AGCCOUNTER} \cdot 0.625 \text{ dB} - \text{C1}$$

C1 is a constant that is hardware specific. For the AX5051-DVK it is 38 dBm.

The first order approximation degrades for low S/N and low bit rates.

A more accurate RSSI formula is

$$\begin{aligned} \text{RSSI2} = & -\text{AGCCOUNTER}[7:1] \cdot 1.25 \text{ dB} + \\ & + 20 \cdot \log_{10}(\text{TRKAMPL}/0x8000) + \\ & + \{ \text{C2} - 80 \cdot \log_{10}(\text{CICDEC}) + 6 \cdot \text{CICSHIFT} \} \\ = & -\text{AGCCOUNTER}[7:1] \cdot 1.25 \text{ dB} + \\ & + 20 \cdot \log_{10}(\text{TRKAMPL}) + \{ \text{C2} - \\ & - 80 \cdot \log_{10}(\text{CICDEC}) + 6 \cdot \text{CICSHIFT} - \\ & - 20 \cdot \log_{10}(0x8000) \} \end{aligned}$$

As soon as the device has been set-up according to section: Programming the Chip the register CICSHIFT can be read and the term in {} can be pre-computed. C2 is a hardware specific constant, for the AX5051-DVK it is 16 dBm for 433 MHz, 12 dBm for 868 MHz, and 14 dBm for 915 MHz. The formula for RSSI2 does not need to be computed with double precision floating point. It can be approximated precisely using a few integer shifts and adds. The following code is used in the AX5051-DVK firmware:

AND9348/D

```
/** \brief RSSI correction table
 *
 * This table contains the values of 80*log10(x) for 0.5<=x<1.0
 */
static const int8_t yf_rssilogtable[32] = {
    -24, -23, -22, -21, -20, -19, -18, -17,
    -16, -15, -15, -14, -13, -12, -11, -11,
    -10, -9, -9, -8, -7, -7, -6, -5,
    -5, -4, -3, -3, -2, -2, -1, -1
};
/**
 * \brief Return bandwidth specific AGC reference level
 *
 * Due to the gain of internal filters, the reference level for the
 * AGC routine is bandwidth specific. This routine computes the AGC
 * reference level. It is 14 dBm-80*log10(CICDEC)+6*CICSHIFT
 * \returns the bandwidth specific AGC reference level in dBm
 */
static int8_t yellowfoot_get_agcref(void)
{
    // 240: 80*log10(1024)
    // 14: board specific reference level
    int8_t r = 14-240;
    uint16_t t = spi_read16(AX5051_REG_CICDECHI);
    if (!t)
        return -128;
    while (t < 512) {
        t <<= 1;
        r += 24;
    }
    t >>= 4;
    r -= yf_rssilogtable[((uint8_t)t) - 32];
    r += 6 * (spi_read(AX5051_REG_CICSHIFT) & 0x1F);
    return r;
}
/**
 * \brief Return current AGC value
 *
 * \returns the current AGC value in dBm
 */
int8_t yellowfoot_get_agc(void)
{
    int16_t agc = spi_read(AX5051_REG_AGCCOUNTER) & 0xfe;
    uint16_t trkAMPL = spi_read16(AX5051_REG_TRKAMPLITUDEHI);
    if (!trkAMPL)
        return -128;
    agc <<= 1;
    agc += (agc >> 2);
    agc = -agc;
    while (trkAMPL < 0x4000) {
        trkAMPL <<= 1;
        agc -= 24;
    }
    trkAMPL >>= 9;
    agc += yf_rssilogtable[((uint8_t)trkAMPL) - 32];
    return (int8_t)(agc >> 2) + yellowfoot_get_agcref();
}
```

AND9348/D

REGISTER BANK DESCRIPTION

This section describes the bits of the register bank in detail. The registers are grouped by functional block to facilitate programming.

No checks are made whether the programmed combination of bits makes sense! Bit 0 is always the LSB.

NOTES: Whole registers or register bits marked as reserved should be kept at their default values. All addresses not documented here must not be accessed, neither in reading or in writing.

Table 12. CONTROL REGISTER MAP

Addr	Name	Dir	Reset	Bit								Description	
				7	6	5	4	3	2	1	0		
Revision & Interface Probing													
0	REVISION	R	00010100	SILICONREV(7:0)								Silicon Revision	
1	SCRATCH	RW	11000101	SCRATCH(7:0)								Scratch Register	
Operating Mode													
2	PWRMODE	RW	0----0000	RST	-	-	-	PWRMODE(3:0)			Power Mode		
Crystal oscillator, Part 1													
3	XTALOSC	RW	----0010	-	-	-	-	XTALOSCGM(3:0)			GM of Crystal Oscillator		
FIFO, Part 1													
4	FIFOCTRL	RW	-----11	FIFOSTAT(1:0)		FIFO OVER	FIFO UNDER	FIFO FULL	FIFO EMPTY	FIFOCMD(1:0)		FIFO Control	
5	FIFODATA	RW	-----	FIFODATA(7:0)								FIFO Data	
Interrupt Control													
6	IRQMASK	RW	--000000	-	-	IRQMASK(5:0)					IRQ Mask		
7	IRQREQUEST	R	-----	-	-	IRQREQUEST(5:0)					IRQ Request		
Interface & Pin Control													
8	IFMODE	RW	----0011	-	-	-	-	IFMODE(3:0)			Interface Mode		
0C	PINCFG1	RW	11111000	Reserved			IRQZ	Reserved		SYSCLK(3:0)		Pin Configuration 1	
0D	PINCFG2	RW	00000000	TST_PINS			IRQE	Reserved		IRQI	Reserved	Pin Configuration 2	
0E	PINCFG3	R	-----	-	-	-	SYSCLKR		Reserved		IRQR	Reserved	Pin Configuration 3
0F	IRQINVERSION	RW	--000000	-	-	-	-	IRQINVERSION(3:0)			IRQ Inversion		
Modulation & Framing													
10	MODULATION	RW	-0000010	-	MODULATION(6:0)						Modulation		
11	ENCODING	RW	----0010	-	-	-	-	ENC MANCH	ENC SCRAM	ENC DIFF	ENC INV	Encoder/Decoder Settings	
12	FRAMING	RW	00000000	FRMRX	HSUPP	CRCMODE(1:0)		FRMMODE(2:0)		FABORT		Framing settings	
14	CRCINIT3	RW	11111111	CRCINIT(31:24)								CRC Initialisation Data or Preamble	
15	CRCINIT2	RW	11111111	CRCINIT(23:16)								CRC Initialisation Data or Preamble	
16	CRCINIT1	RW	11111111	CRCINIT(15:8)								CRC Initialisation Data or Preamble	
17	CRCINIT0	RW	11111111	CRCINIT(7:0)								CRC Initialisation Data or Preamble	
Voltage Regulator													
1B	VREG	R	-----	-	-	-	-	SSDS	SSREG	SDS	SREG	Voltage Regulator Status	
Synthesizer													
20	FREQ3	RW	00111001	FREQ(31:24)								Synthesizer Frequency	

AND9348/D

Table 12. CONTROL REGISTER MAP (CONTINUED)

Addr	Name	Dir	Reset	Bit								Description
				7	6	5	4	3	2	1	0	
Synthesizer												
21	FREQ2	RW	00110100	FREQ(23:16)								Synthesizer Frequency
22	FREQ1	RW	11001100	FREQ(15:8)								Synthesizer Frequency
23	FREQ0	RW	11001101	FREQ(7:0)								Synthesizer Frequency
25	FSKDEV2	RW	00000010	FSKDEV(23:16)								FSK Frequency Deviation
26	FSKDEV1	RW	01100110	FSKDEV(15:8)								FSK Frequency Deviation
27	FSKDEV0	RW	01100110	FSKDEV(7:0)								FSK Frequency Deviation
28	IFFREQHI	RW	00100000	IFFREQ(15:8)								2nd LO/IF Frequency
29	IFFREQLO	RW	00000000	IFFREQ(7:0)								2nd LO/F Frequency
2C	PLLLOOP	RW	~0011101	-	Reserved	BANDSEL	PLLCPI(2:0)		FLT(1:0)		Synthesizer Loop Filter Settings	
2D	PLL RANGING	RW	00001000	STICKY LOCK	PLL LOCK	RNGERR	RNG START	VCOR(3:0)			Synthesizer VCO Auto-Ranging	
Transmitter												
30	TXPWR	RW	----1000	-	-	-	-	TXRNG(3:0)			Transmit Power	
31	TXRATEHI	RW	00001001	TXRATE(23:16)								Transmitter Bit Rate
32	TXRATEMID	RW	10011001	TXRATE(15:8)								Transmitter Bit Rate
33	TXRATELO	RW	10011010	TXRATE(7:0)								Transmitter Bit Rate
34	MODMISC	RW	-----11	-	-	-	-	-	-	Reserved	PTTCLK GATE	Misc RF Flags
FIFO, Part 2												
35	FIFOCOUNT	R	-----	-	-	-	-	FIFOCOUNT(2:0)			FIFO Fill Stare	
36	FIFOTHRESH	RW	-----000	-	-	-	-	FIFOTHRESH(2:0)			FIFO Threshold	
37	FIFOCONTROL2	RW	0-----00	CLEAR	-	-	-	-	-	STOPONERR(1:0)	Additional FIFO Control	
Receiver												
3A	AGCATTACK	RW	00010110	-	-	-	AGCATTACK(4:0)			AGC Attack		
3B	AGCDECAY	RW	0~010011	Reserved	-	Reserved	AGCDECAY(4:0)			AGC Decay		
3C	AGCCOUNTER	R	-----	AGCCOUNTER(7:0)								AGC Current Value
3D	CICSHIFT	R	--000100	-	-	Reserved	CICSHIFT(4:0)			CIC Shift Factor		
3F	CICDEC	RW	00000100	-	-	CICDEC(5:0)			CIC Decimation Factor			
40	DATARATEHI	RW	00011010	DATARATE(15:8)								Data rate
41	DATARATELO	RW	10101011	DATARATE(7:0)								Data rate
42	TMGGAINHI	RW	00000000	TIMINGGAIN(15:8)								Timing Gain
43	TMGGAINLO	RW	11010101	TIMINGGAIN(7:0)								Timing Gain
44	PHASEGAIN	RW	00~0011	Reserved		-	-	PHASEGAIN(3:0)			Phase Gain	
45	FREQGAIN	RW	00001010	0	Reserved			FREQGAIN(3:0)			Frequency Gain	
46	FREQGAIN2	RW	-----1010	-	-	-	-	FREQGAIN2(3:0)			Frequency Gain 2	
47	AMPLGAIN	RW	-----00110	-	-	-	Reserved	AMPLGAIN(3:0)			Amplitude Gain	
48	TRKAMPLHI	R	-----	TRKAMPL(15:8)								Amplitude Tracking

AND9348/D

Table 12. CONTROL REGISTER MAP (CONTINUED)

Addr	Name	Dir	Reset	Bit								Description
				7	6	5	4	3	2	1	0	
Receiver												
49	TRKAMPLLO	R	_____	TRKAMPL(7:0)								Amplitude Tracking
4A	TRKPHASEHI	R	_____	-	-	-	-	TRKPHASE(11:8)			Phase Tracking	
4B	TRKPHASELO	R	_____	TRKPHASE(7:0)								Phase Tracking
4C	TRKFREQHI	R	_____	TRKFREQ(15:8)								Frequency Tracking
4D	TRKFREQLO	R	_____	TRKFREQ(7:0)								Frequency Tracking
Crystal Oscillator, Part 2												
4F	XTALCAP	RW	--000000	-	-	XTALCAP(5:0)			Crystal Oscillator Tuning Capacitance			
Misc												
72	PLLVCOI	RW	--000100	-	-	Reserved		VCO_I(2:0)		Synthesizer VCO current Must be set to 001		
7A	LOCURST	RW	00110000	LOCURST		Reserved				Transmitter Mode		
7C	REF	RW	--100011	-	-	Reserved		REF_I(2:0)		Reference Adjust		
7D	RXMISC	RW	--110110	-	-	Reserved			RXIMIX(1:0)		Misc RF settings RXIMIX(1:0) must be set to 01	

Register Descriptions

REVISION

The register holds the revision index of the chip.

Table 13. REVISION

Name	Bits	R/W	Reset	Description
REVISION	7:0	R	00010100	Silicon Revision

SCRATCH

The SCRATCH register does not affect the function of the chip in any way. It is intended for the micro-controller to test communication to the AX5051.

Table 14. SCRATCH

Name	Bits	R/W	Reset	Description
SCRATCH	7:0	R	11000101	Scratch Register

PWRMODE

This register controls the powering and reset of the various blocks on the chip.

Table 15. PWRMODE

Name	Bits	R/W	Reset	Description
RST	7	RW	0	Reset; setting this bit to 1 resets the whole chip. This bit does not auto-reset - the chip remains in reset state until this bit is cleared.
PWRMODE	3:0	RW	0000	Powermode; see Table 3: PWRMODE Register States

NOTES: Before RST can be written to 1, the SPI interface of the chip needs to be reset. This is done by setting the SEL line to high. See register LOCURST for limitations on the sequences of PWRMODE settings.

XTALOSC

This register controls the transconductance of the crystal oscillator. Optimal settings will depend on the characteristics of the specific crystal that is used. For a table

containing the values as a function of the register settings see the AX5051 Datasheet.

Table 16. XTALOSC

Name	Bits	R/W	Reset	Description
XTALOSCGM	3:0	RW	0010	Transconductance of the Crystal Oscillator

For other crystal oscillator settings see the register XTALCAP.

FIFOCTRL

This register is used to send control commands (depending on the selected frame mode) and holds the FIFO status information. For further FIFO settings see the

registers: FIFODATA, FIFOCOUNT, FIFOTHRESH, FIFOCONTROL2.

Table 17. FIFOCTRL

Name	Bits	R/W	Reset	Description
FIFOCMD	1:0	RW	11	FIFO command bits (written to FIFO during next write to FIFODATA), see section Receive and Transmit for exact operation of these bits
FIFO EMPTY	2	R	-	FIFO is empty if 1
FIFO FULL	3	R	-	FIFO is full if 1; if 1 the FIFO contains 4 words.
FIFO UNDER	4	R	-	FIFO under run occurred since last read of FIFOCTRL when 1. This bit is set when a read operation by the transmitter (transmit mode) or the micro-controller (receive mode) was attempted while the FIFO was empty.
FIFO OVER	5	R	-	FIFO over run occurred since last read of FIFOCTRL when 1. This bit is set when a write operation by the receiver (receive mode) or the micro-controller (transmit mode) was attempted while the FIFO was full.
FIFOSTAT	7:6	R	-	FIFO Status bits associated with current FIFO top word; see section Receive and Transmit for exact operation of these bis

FIFODATA

This register is used to read from and write to the 4 level x 10 bit FIFO. For further information on FIFO settings see section: Receive and Transmit and the register FIFOCTRL.

Table 18. FIFODATA

Name	Bits	R/W	Reset	Description
FIFODATA	7:0	RW	-	FIFO access register

IRQMASK

This register allows to mask or de-mask interrupts. For further information on interrupt related settings see section:

Interrupts and the registers IRQREQUEST and IRQINVERSION as well as PINCFG1 and PINCFG2.

Table 19. IRQMASK

Name	Bits	R/W	Reset	Description
IRQMIFONOTEMPTY	0	RW	0	FIFO not empty interrupt enable
IRQMIFONOTFULL	1	RW	0	FIFO not full interrupt enable
IRQMPLLUNLOCK	2	RW	0	Synthesizer lock lost interrupt enable
IRQMPLLRNGDONE	3	RW	0	Synthesizer auto-ranging done interrupt enable
IRQMFIOTHRESH	4	RW	0	FIFO count ≥ threshold interrupt enable
IRQMFIERROR	5	RW	0	FIFO error (overrun or underrun) interrupt enable

IRQREQUEST

This register indicates pending interrupts. For further information on interrupt related settings see section:

“Interrupts” and the registers IRQMASK and IRQINVERSION as well as PINCFG1 and PINCFG2.

Table 20. IRQREQUEST

Name	Bits	R/W	Reset	Description
IRQRQFIFONOTEMPTY	0	R	-	FIFO not empty interrupt pending
IRQRQFIFONOTFULL	1	R	-	FIFO not full interrupt pending
IRQRQPLLUNLOCK	2	R	-	Synthesizer lock lost interrupt pending
IRQRQPLLRNGDONE	3	R	-	Synthesizer auto-ranging done interrupt pending

AND9348/D

Table 20. IRQREQUEST (CONTINUED)

Name	Bits	R/W	Reset	Description
IRQMFIFOTHRESH	4	RW	0	FIFO count \geq threshold interrupt enable
IRQMFIFOERROR	5	RW	0	FIFO error (overrun or underrun) interrupt enable

IFMODE

This register allows to set the chip into production test modes, the test modes are not intended for usage in an application.

Table 21. IFMODE

Name	Bits	R/W	Reset	Description
IFMODE	3:0	RW	0011	This register must be set to 0000

PINCFG1

This register allows to configure the SYSCLK and IRQ pins for application specific use.

Table 22. PINCFG1

Name	Bits	R/W	Reset	Description
SYSCLK	3:0	RW	1000	See Table 23.
IRQZ	5	RW	1	1: configure IRQ_TXEN pin as input (tri-state) 0: configure IRQ_TXEN pin as output This bit is only active if IRQE = 1

Table 23. SYSCLK BIT VALUES

SYSCLK Bits	Meaning
0000	SYSCLK pin as Output '0'
0001	SYSCLK pin as Output '1'
0010	SYSCLK pin as input (tri-state)
0011	SYSCLK Output inverted f_{XTAL}
0100	SYSCLK Output f_{XTAL}
0101	SYSCLK Output $f_{XTAL}/2$
0110	SYSCLK Output $f_{XTAL}/4$
0111	SYSCLK Output $f_{XTAL}/8$
1000	SYSCLK Output $f_{XTAL}/16$
1001	SYSCLK Output $f_{XTAL}/32$
1010	SYSCLK Output $f_{XTAL}/64$
1011	SYSCLK Output $f_{XTAL}/128$
1100	SYSCLK Output $f_{XTAL}/256$
1101	SYSCLK Output $f_{XTAL}/512$
1110	SYSCLK Output $f_{XTAL}/1024$
1111	SYSCLK Output $f_{XTAL}/2048$

NOTE: Care must be taken to keep the reserved bits PINCFG1[7:6] at their default value of 11. If this is not done, then large currents may flow through the device pins TST1, TST2 or TST3.

PINCFG2

This register allows to configure the IRQ pin to function as a General Purpose I/O (GPIO) pin rather than having its special default function.

IRQE is used to enable the special function of the IRQ pin or set it to GPIO. IRQI is used to set the state of the pin, if

defined as GPIO and configured as output in PINCFG1. If the pin is configured as special function pin, then bit IRQI is used to chose if the output signal should be inverted.

Table 24. PINCFG2

Name	Bits	R/W	Reset	Description	
				GPIO pin	Special pin
IRQI	1	RW	0	0: set IRQ pin to '1' 1: set IRQ pin to '0'	0: level high active interrupt 1: level low active interrupt
IRQE	5	RW	0	0: IRQ pin carries the interrupt 1: IRQ pin is a general purpose I/O (GPIO)	
TST_PINS	7:6	RW	00	Configuration of TST pins Must be set to 11	

NOTE: Note Care must be taken to keep the reserved bit PINCFG2[4] at its default value of 0, as well as writing the bits TST_PINS[1:0] to 11. If this is not done, then large currents may flow through the device pins TST1, TST2 or TST3.

PINCFG3

GPIO state register: This register holds the signals on the GPIO pins. It can be used to read back signals, if PINCFG1 configures the respective pin as input.

Table 25. PINCFG3

Name	Bits	R/W	Reset	Description
IRQR	1	R	-	Logic State of IRQ Pin
SYSCLKR	4	R	-	Logic State of SYSCLK Pin

IRQINVERSION

This register allows to invert the logic levels of the level-triggered interrupts.

Table 26. IRQINVERSION

Name	Bits	R/W	Reset	Description
IRQINVFIFONOTEMPTY	0	RW	0	FIFO not empty interrupt inversion
IRQINVFIFONOTFULL	1	RW	0	FIFO not full interrupt inversion
IRQINVPLLUNLOCK	2	RW	0	Synthesizer lock lost interrupt inversion
IRQINVPLLRNGDONE	3	RW	0	Synthesizer auto-ranging done interrupt inversion
IRQNFIFOTHRESH	4	RW	0	FIFO count ≥ threshold interrupt enable
IRQNFIFOERROR	5	RW	0	FIFO error (overrun or underrun) interrupt enable

AND9348/D

MODULATION

This register sets the modulation type. For details on coding see also section: Programming the Chip.

Table 27. MODULATION

Name	Bits	R/W	Reset	Description
MODULATION	6:0	RW	00000010	See Table 28: Modulation Register Programming

Table 28. MODULATION REGISTER PROGRAMMING

SYSCLK Bits	Meaning
0000000	ASK
0000010	ASK Shaped
0000100	PSK
0000101	PSK Shaped
0000110	OQSK
0000111	MSK
10nnnnn	FSK, nnnnn = FSKMUL-1

ENCODING

The register configures the encoder.

Table 29. ENCODING

Name	Bits	R/W	Reset	Description
ENC INV	0	RW	0	Invert data if set to 1
ENC DIFF	1	RW	1	Differential encode/decode data if set to 1
ENC SCRAM	2	RW	0	Enable scrambler/descrambler if set to 1
ENC MANCH	3	RW	0	Enable manchester encoding/decoding. FM0/FM1 may be achieved by also appropriately setting ENC DIFF and ENC INV

The intention of the scrambler is the removal of tones contained in the transmit data, i.e. to randomize the transmit spectrum. The scrambler polynomial is $1 + X^{12} + X^{17}$, it is

therefore compatible to the K9NG/G3RUH Satellite Modems.

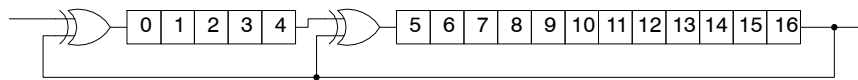

Figure 21. Scrambler Operation

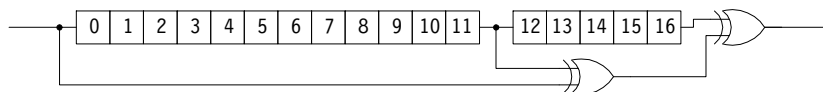

Figure 22. Descrambler Operation

Figure 21 shows a schematic circuit diagram for the scrambler, and Figure 22 for the descrambler. The numbered boxes represent a delay by one bit.

Figure 23 shows a few well known encoding formats used in telecom and Table 30 describes them.

AND9348/D

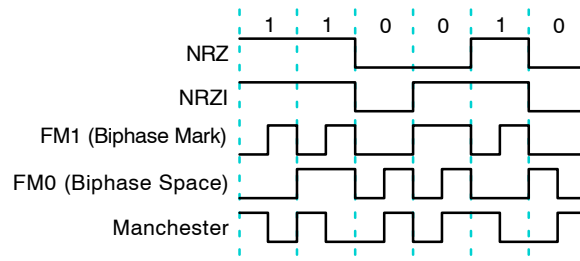

Figure 23. Customary Telecom Encoding Modes

Table 30. CUSTOMARY TELECOM MODES DESCRIPTION

Name	Bits	Description
NRZ	INV = 0, DIFF = 0, SCRAM = 0, MANCH = 0	NRZ represents 1 as a high signal level, 0 as a low signal level. NRZ performs no change
NRZI	INV = 1, DIFF = 1, SCRAM = 0, MANCH = 0	NRZI represents 1 as no change in the signal level, and 0 as a change in the signal level. NRZI is recommended for HDLC. The HDLC bit stuffing ensures that there are periodic zeros and thus transitions, and the encoding is inversion invariant, and therefore useable for PSK.
FM1	INV = 1, DIFF = 1, SCRAM = 0, MANCH = 1	FM1 (Biphase Mark) always ensures transitions at bit edges. It encodes 1 as a transition at the bit center, and 0 as no transition at the bit center.
FM0	INV = 0, DIFF = 1, SCRAM = 0, MANCH = 1	FM0 (Biphase Space) always ensures transitions at bit edges. It encodes 1 as no transition at the bit center, and 0 as a transition at the bit center.
Manchester	INV = 0, DIFF = 0, SCRAM = 0, MANCH = 1	Manchester encodes 1 as a 10 pattern, and 0 as a 01 pattern. Manchester is not inversion invariant.

Guidelines:

- Manchester, FM0, and FM1 are not recommended for new systems, as they double the bit rate
- In HDLC mode, use NRZI, NRZI+Scrambler, or NRZ+Scrambler. If HDLC is to be transmitted over PSK, NRZI and NRZI+Scrambler are valid choices.
- In 802.15.4, use NRZ mode.
- In Raw modes, the choice depends on the legacy system to be implemented.

FRAMING

The register sets the framing mode and the CRC type.

Table 31. FRAMING

Name	Bits	R/W	Reset	Description
FABORT	0	S	0	Write 1 to abort current HDLC packet
FRMMODE	3:1	RW	000	Defines framing type. See Table 32
CRCMODE	5:4	RW	00	Defines the CRC type. See Table 33
HSUPP	6	RW	0	Suppress unneeded abort/flag/data indications.
MARCHLEN	6:4	RW	000	Defines the preamble length. The preamble length is 4(MATCHLEN+1) bits. This field is only available in Raw with Preamble Match mode.
FRMRX	7	R	0	If one, packet reception is in progress. Otherwise, the receiver searches for a preamble/HDLC Flag.

Table 32. FRAME MODE BIT VALUES

FRMMODE Bits	Meaning
000	Raw

Table 32. FRAME MODE BIT VALUES (CONTINUED)

001	Raw, Soft-Decision
010	HDLC
110	802.15.4
111	Reserved for future use

Table 33. CRC MODE BIT VALUES

CRCMODE Bits	Meaning
00	CCITT (16 bit)
01	CRC-16
10	CRC-32
11	Invalid

CRCINIT3, CRCINIT2, CRCINIT1, CRCINIT0

This register can be used to set the reset value of the CRC calculation. Normally this register is left at all ones.

Table 34. CRCINIT3, CRCINIT2, CRCINIT1, CRCINIT0

Name	Bits	R/W	Reset	Description
CRCINIT	31:0	RW	0xFFFFFFFF	CRC Reset Value; normally all ones

In Raw Mode with Preamble Match mode, this register holds the preamble against which the incoming bit stream is compared. The comparison is LSB first. The preamble should be written to CRCINIT with the MSB aligned. For

example, if MATCHLEN is 2, i.e. a 12 bit match is requested, the pattern should be written to CRCINIT(31:20). CRCINIT(20) should be transmitted first.

VREG

This contains status information of the internal voltage regulator.

Table 35. CRCINIT3, CRCINIT2, CRCINIT1, CRCINIT0

Name	Bits	R/W	Reset	Description
SREG	0	R	–	This bit is 1 if the voltage regulator is in high-power mode and the output voltage is > 2.3 V
SDS	1	R	–	1 if the voltage regulator start-up is complete
SSREG	2	R	–	Sticky version of SREG, meaning that this bits is 0 if it was 0 at any time since the last read access
SSDS	3	R	–	Sticky version of SDS, meaning that bit is 0 if it was 0 at any time since the last read access

FREQ3, FREQ2, FREQ1, FREQ0

This registers are used to set the carrier frequency.

Table 36. FREQ3, FREQ2, FREQ1, FREQ0

Name	Bits	R/W	Reset	Description
FREQ	31:0	RW	0x3934CCCD	Frequency; FREQ = [$f_{\text{CARRIER}}/f_{\text{XTAL}} \cdot 2^{24} + 1/2$]

Note that to program frequencies in the 433 MHz band registers FREQ3, FREQ2, FREQ1, FREQ0 must be programmed to appropriate values and the bit BANDSEL in the PLLLOOP register must be set to 1.

For the 868/930 MHz band the ratio $f_{\text{CARRIER}}/f_{\text{XTAL}} = \text{FREQ}/2^{24}$ should not be in the range [62.5 .. 64.5].

For the 433 MHz band the ratio $2 \cdot f_{\text{CARRIER}}/f_{\text{XTAL}} = \text{FREQ}/2^{23}$ should not be in the range [62.5 .. 64.5].

If a 16 MHz reference crystal is used, then all SRD frequencies can be reached without limitation.

FSKDEV2, FSKDEV1, FSKDEV0

These registers are used to set the FSK frequency deviation.

Table 37. FSKDEV2, FSKDEV1, FSKDEV0

Name	Bits	R/W	Reset	Description
FSKDEV	23:0	RW	0x026666	(G)FSK Frequency Deviation; FSKDEV = [$f_{\text{DEVIATION}}/f_{\text{XTAL}} \cdot 2^{24} + 1/2$]

NOTE: $f_{\text{DEVIATION}}$ is actually half the deviation.
The mark (bit = 1) frequency is $f_{\text{CARRIER}} + f_{\text{DEVIATION}}$, the space (bit = 0) frequency is $f_{\text{CARRIER}} - f_{\text{DEVIATION}}$.
 $f_{\text{DEVIATION}} = h/2 \cdot \text{BITRATE}$

IFFREQHI, IFFREQLO

These registers are used to set the IF frequency, for most cases the nominal frequency of 1 MHz is suitable.

Table 38. IFFREQHI, IFFREQLO

Name	Bits	R/W	Reset	Description
IFFREQ	23:0	RW	0x2000	IF Frequency; IFFREQ = [$f_{\text{IF}}/f_{\text{XTAL}} \cdot 2^{17} + 1/2$]

PLLLOOP

This register allows to configure the synthesizer loop bandwidth and the frequency band. For recommendations

on settings to use see Table 6: Recommended synthesizer loop bandwidth settings.

Table 39. PLLLOOP

Name	Bits	R/W	Reset	Description
FLT	1:0	RW	01	Filter setting. See Table 40
PLLCPI	4:2	RW	111	Charge pump current multiplier
BANDSEL	6:5	RW	00	Band selection. See Table 41

Table 40. FILTER BIT VALUES

FLT Bits	Meaning
00	Invalid
01	Loop Filter configuration with nominal bandwidth
10	Boosted loop filter configuration with x5 nominal bandwidth
11	Boosted loop filter configuration with x2 nominal bandwidth

PLL RANGING

This register is used to initiate ranging of the synthesizer VCO. It also holds the VCO range that is currently being

Table 41. BAND SELECTION BIT VALUES

BANDSEL Bit	Meaning
0	868/915 MHz
1	433 MHz

Note that to program frequencies in the 433 MHz band registers *FREQ3*, *FREQ2*, *FREQ1*, *FREQ0* must be programmed to appropriate values and the bit *BANDSEL* in the *PLLLOOP* register must be set to 1.

used. For a description of the VCO ranging procedure see section: Synthesizer VCO Auto-Ranging.

Table 42. PLLRANGING

Name	Bits	R/W	Reset	Description
VCOR	3:0	RW	1000	VCO Range
RNG START	4	RS	0	Synthesizer VCO auto-ranging; Write 1 to start auto-ranging, bit clears when auto-ranging done
RNGERR	5	R	-	Ranging Error; this bit is set when RNG START transitions from 1 to 0 and the programmed frequency cannot be achieved
PLL LOCK	6	R	-	Synthesizer LOCK indicates the state of the synthesizer at the moment of the register access. Synthesizer is locked if 1
STICKY LOCK	7	R	-	STICKY LOCK indicates, the state of synthesizer since last read of the register. if 0, synthesizer lost lock after last read of PLLRANGING register

TXPWR

This register programs the transmit output power.

Table 43. TXPWR

Name	Bits	R/W	Reset	Description
TXRNG	3:0	RW	1000	Transmit Power, see AX5051 Datasheet for details.

TXRATEHI, TXRATEMID, TXRATELO

These registers set the transmit bit rate.

Table 44. TXRATEHI, TXRATEMID, TXRATELO

Name	Bits	R/W	Reset	Description
TXRATE	23:0	RW	0x09999A	Transmit Bitrate; $TXRATE = [\text{BITRATE} / f_{XTAL} \cdot 2^{24} + \frac{1}{2}]$

MODMISC

The behaviour of the transmitter if the synthesizer loses lock is set with this register.

Table 45. MODMISC

Name	Bits	R/W	Reset	Description
PTTLCK GATE	0	RW	1	If set to 1 then the transmitter is automatically disabled if the synthesizer loses lock

AND9348/D

FIFOCOUNT

This register allows the micro-controller to obtain the number of words contained in the FIFO. FIFOCOUNT returns the number of words that can be read without

underrun. Since the AX5051 contains a 4 level deep FIFO, the FIFO will contain 4 – FIFOCOUNT empty words. 4 – FIFOCOUNT can be written without an overrun error.

Table 46. FIFOCOUNT

Name	Bits	R/W	Reset	Description
FIFOCOUNT	2:0	R	---	Current number of FIFO words

FIFOTHRESH

This register specifies the FIFO count that must be exceeded to activate the FIFO threshold interrupt. That is, if IRQMFIFOTHRESH is one and FIFOCOUNT >

FIFOTHRESH, an interrupt is requested. IRQINVFIFOTHRESH may be used to invert the sense of this interrupt.

Table 47. FIFOTHRESH

Name	Bits	R/W	Reset	Description
FIFOTHRESH	2:0	RW	000	FIFO threshold

FIFOCONTROL2

This register specifies the action the transceiver should take on FIFO error, and allows the FIFO to be cleared.

If a FIFO error (an overrun or an underrun) occurs, the transceiver performs the action specified in STOPONERR, but does not change the PWRMODE register. Thus, to

recover from the error, the software must first write SYNTHRX, SYNTHTX or STANDBY into PWRMODE, and then clear the overrun and underrun bits by reading FIFOSTAT.

Table 48. FIFOCONTROL2

Name	Bits	R/W	Reset	Description
STOPONERR	1:0	RW	00	This bitfield determines what should happen on FIFO overrun or underrun, See table 49
CLEAR	7	W	0	Clear the FIFO by writing 1. This bit is self clearing.

Table 49. CRC MODE BIT VALUES

STOPONERR Bits	Meaning
00	No action taken, transceiver continues
01	Switch off transceiver, continue synthesizer
10	Switch off transceiver and synthesizer, continue crystal oscillator
11	Switch off everything

Do not use STOPONERR = 10 or 11 if bit LOCURST = 1 in register LOCURST.

AGCATTACK

This register along with AGCDECAY controls the AGC (automatic gain control) loop slopes, and thus the speed of

the gain adjustments. The higher the bit rate, the faster the AGC loop should be set.

Table 50. AGCATTACK

Name	Bits	R/W	Reset	Description
AGCATTACK	4:0	RW	10110	AGC gain reduction speed; $2.5 \text{ dB} \cdot f_{\text{XTAL}} 2^{\text{AGCATTACK}-27}$ [dB/s]

1. The recommended AGCATTACK settings can be found in Table 8: AGC Dynamics Register Values.

AGCDECAY

This register along with AGCATTACK controls the AGC (automatic gain control) loop slopes, and thus the speed of

the gain adjustments. The higher the bit rate, the faster the AGC loop should be set.

Table 51. AGCDECAY

Name	Bits	R/W	Reset	Description
AGCDECAY	4:0	RW	10011	AGC gain increase speed; $2.5 \text{ dB} \cdot f_{\text{XTAL}} 2^{\text{AGCDECAY}-27}$ [dB/s]

1. The recommended AGCDECAY settings can be found in Table 8: AGC Dynamics Register Values.

AGCCOUNTER

This register contains the current setting of the automatic gain control (AGC) and can be used to calculate an RSSI

value (RSSI1). See section: RSSI for details on RSSI calculation.

Table 52. AGCCOUNTER

Name	Bits	R/W	Reset	Description
AGCCOUNTER	7:0	R	-	Current AGC Gain, in 0.625 dB steps

CICSHIFT

This register must be read to be able to make the calculations for RSSI2, the calculation is described in

section: RSSI. CICSHIFT is updated when CICDEC is written.

Table 53. CICSHIFT

Name	Bits	R/W	Reset	Description
CICSHIFT	4:0	RW	00100	CIC Shift factor, used for RSSI2 calculation

CICDEC

This register sets the bandwidth of the digital channel filter. For detailed information on programming this register see section: Parameter Programming.

Table 54. CICDECHI, CICDECLO

Name	Bits	R/W	Reset	Description
CICDEC	5:0	RW	0x04	CIC Decimation factor. CICDEC = $[(1.5 \cdot f_{\text{XTAL}})/(8 \cdot 1.2 \cdot \text{BW})]$, if TMGCORRFRAC > 16 or CICDEC = $[(1.5 \cdot f_{\text{XTAL}})/(8 \cdot 1.4 \cdot \text{BW})]$, if TMGCORRFRAC ≤ 16

DATARATEHI, DATARATELO

These registers specify the receiver bit rate, relative to the channel filter bandwidth. For detailed information on

programming these registers see section: Parameter Programming.

Table 55. DATARATEHI, DATARATELO

Name	Bits	R/W	Reset	Description
DATARATE	15:0	RW	0x1AAB	DATARATE = $[(2^{10} \cdot f_{\text{XTAL}})/(\text{BITRATE} \cdot \text{CICDEC} \cdot \text{FSKMUL}) + \frac{1}{2}]$

TMGGAINHI, TMGGAINLO

These registers specify the aggressiveness of the receiver bit timing recovery. More aggressive settings allow the receiver to synchronize with shorter preambles, at the expense of more timing jitter and thus a higher bit error rate

at a given signal-to-noise ratio. For detailed information on programming this register see section: Parameter Programming.

Table 56. TMGGAINHI, TMGGAINLO

Name	Bits	R/W	Reset	Description
TMGGAIN	15:0	RW	0x00D5	$TMGGAIN = [((FSKMUL \cdot DATARATE)/TMGCRFRAC) + \frac{1}{2}]$

PHASEGAIN

This register controls the bandwidth of the phase tracking loop. For detailed information on programming this register see section: Parameter Programming.

Table 57. PHASEGAIN

Name	Bits	R/W	Reset	Description
PHASEGAIN	3:0	RW	0011	Bandwidth of the phase recovery loop

FREQGAIN

This register controls the bandwidth of the frequency tracking loop. For detailed information on programming this register see section: Parameter Programming.

Table 58. FREQGAIN

Name	Bits	R/W	Reset	Description
FREQGAIN	3:0	RW	1010	Bandwidth of the frequency recovery loop

FREQGAIN2

This register controls the bandwidth of the frequency tracking loop. For detailed information on programming this register see section: Parameter Programming.

Table 59. FREQGAIN2

Name	Bits	R/W	Reset	Description
FREQGAIN2	3:0	RW	1010	Bandwidth of the frequency recovery loop

AMPLGAIN

This register controls the bandwidth of the amplitude tracking loop. For detailed information on programming this register see section: Parameter Programming.

Table 60. AMPLGAIN

Name	Bits	R/W	Reset	Description
AMPLGAIN	3:0	RW	0110	Bandwidth of the amplitude recovery loop

TRKAMPLHI, TRKAMPLLO

This register holds the current value of the amplitude of the received signal.

Table 61. TRKAMPLHI, TRKAMPLLO

Name	Bits	R/W	Reset	Description
TRKAMPL	15:0	R	-	Current amplitude tracking value; Used for RSSI2 calculation

This is a signed 16 bit register and should only be read using the 16 bit read access sequence. See section: RSSI for

details on how to use this register to derive a high resolution RSSI value (RSSI2).

TRKPHASEHI, TRKPHASELO

This register holds the current value of the phase offset to the received signal.

Table 62. TRKPHASEHI, TRKPHASELO

Name	Bits	R/W	Reset	Description
TRKPHASE	11:0	R	-	Current phase tracking value

This is an unsigned 16 bit register (only 12 bits used) and should only be read using the 16 bit read access sequence.

$(\text{TRKPHASE}/2^{11}) \cdot \pi$ converts the register contents to radians.

TRKFREQHI, TRKFREQLO

This register holds the current value of the frequency offset of the received signal.

Table 63. TRKFREQHI, TRKFREQLO

Name	Bits	R/W	Reset	Description
TRKFREQ	15:0	R	-	Current frequency tracking value

This is a signed 16 bit register and should only be read using the 16 bit read access sequence.

For a description of the special handling required for this register to guarantee correct PSK reception see the section PSK Frequency Lock.

The current frequency offset estimate is
 $\Delta f = (\text{TRKFREQ}/2^{16}) \cdot \text{BITRATE} \cdot \text{FSKMUL}$

XTALCAP

This register allows to program the tuning capacitor array at pins CLK16P and CLK16N.

Table 64. APEOVER

Name	Bits	R/W	Reset	Description
XTALCAP	5:0	RW	000000	Crystal Oscillator tuning capacitance

For the capacitance values see the AX5051 Datasheet.

PLLVCOI

This register is used to control the current through the synthesizer VCO.

Table 65. APEOVER

Name	Bits	R/W	Reset	Description
VCO_I	2:0	RW	100	Must be set to 001

LOCURST

This bit control the internal transmitter mode.

Table 66. PLLRNG

Name	Bits	R/W	Reset	Description
LOCURST	7	RW	0	Transmitter mode

Writing the bit LOCURST = 1 sets the transmitter to a mode where efficiency and output power are higher than if LOCURST = 0. The LOCURST bit setting does not impact data reception in any way. If LOCURST = 1 is used, then care must be taken to

1. Never switch from PWRMODE setting FULLTX straight to VREGON or POWERDOWN if LOCURST = 1. Always switch first to SYNTHTX after FULLTX.
2. Do not reset the device, neither with the RESET_N pin nor with the RST bit, during FULLTX mode if LOCURST = 1.
3. Do not use the settings STOPONERR = 10 or 11 in register FIFOCONTROL2 together with LOCURST = 1.

4. Do not set LOCURST = 1 in PWRMOD settings POWERDOWN or STANDBY if the sequence FULLTX → SXNTHTX has never been executed since the last device power-up.

If LOCURST = 0 then none of the above limitations apply. Failure to take note of 1–3 can lead to a device state that can only be left with a power-down/power-up sequence. Failure to take note of 4 can lead to the device drawing a large current before entering SYNTHTX or SYNTHRX modes for the first time after power-up.

REF

This register is used to program the master reference current of the AX5051.

Table 67. REF

Name	Bits	R/W	Reset	Description
REF_I	2:0	RW	011	Master reference current, for low power mode set to 101

RXMISC

This register is used to program internal settings of the receiver.

Table 68. RXMISC

Name	Bits	R/W	Reset	Description
RXIMIX	1:0	RW	10	Mixer current, Must be set to 01

REFERENCES

- [1] ON Semiconductor. AX5051 Datasheet, see <http://www.onsemi.com>
- [2] ON Semiconductor. AX5051 Evaluation Software, see <http://www.onsemi.com>
- [3] LAN MAN Standards Committee. Part 15.4: Wireless Medium Access Control (MAC) and Physical Layer (PHY) Specifications for Low-Rate Wireless Personal Area Networks (LR-WPANs). IEEE Computer Society, 2003.
- [4] Wikipedia. High-Level Data Link Control. <http://en.wikipedia.org/wiki/HDLC>
- [5] ON Semiconductor. AX5042/AX5051 Preamble Calculator, see <http://www.onsemi.com>

ON Semiconductor and  are trademarks of Semiconductor Components Industries, LLC dba ON Semiconductor or its subsidiaries in the United States and/or other countries. ON Semiconductor owns the rights to a number of patents, trademarks, copyrights, trade secrets, and other intellectual property. A listing of ON Semiconductor's product/patent coverage may be accessed at www.onsemi.com/site/pdf/Patent-Marking.pdf. ON Semiconductor reserves the right to make changes without further notice to any products herein. ON Semiconductor makes no warranty, representation or guarantee regarding the suitability of its products for any particular purpose, nor does ON Semiconductor assume any liability arising out of the application or use of any product or circuit, and specifically disclaims any and all liability, including without limitation special, consequential or incidental damages. Buyer is responsible for its products and applications using ON Semiconductor products, including compliance with all laws, regulations and safety requirements or standards, regardless of any support or applications information provided by ON Semiconductor. "Typical" parameters which may be provided in ON Semiconductor data sheets and/or specifications can and do vary in different applications and actual performance may vary over time. All operating parameters, including "Typicals" must be validated for each customer application by customer's technical experts. ON Semiconductor does not convey any license under its patent rights nor the rights of others. ON Semiconductor products are not designed, intended, or authorized for use as a critical component in life support systems or any FDA Class 3 medical devices or medical devices with a same or similar classification in a foreign jurisdiction or any devices intended for implantation in the human body. Should Buyer purchase or use ON Semiconductor products for any such unintended or unauthorized application, Buyer shall indemnify and hold ON Semiconductor and its officers, employees, subsidiaries, affiliates, and distributors harmless against all claims, costs, damages, and expenses, and reasonable attorney fees arising out of, directly or indirectly, any claim of personal injury or death associated with such unintended or unauthorized use, even if such claim alleges that ON Semiconductor was negligent regarding the design or manufacture of the part. ON Semiconductor is an Equal Opportunity/Affirmative Action Employer. This literature is subject to all applicable copyright laws and is not for resale in any manner.

PUBLICATION ORDERING INFORMATION

LITERATURE FULFILLMENT:

Literature Distribution Center for ON Semiconductor
 19521 E. 32nd Pkwy, Aurora, Colorado 80011 USA
Phone: 303-675-2175 or 800-344-3860 Toll Free USA/Canada
Fax: 303-675-2176 or 800-344-3867 Toll Free USA/Canada
Email: orderlit@onsemi.com

N. American Technical Support: 800-282-9855 Toll Free
 USA/Canada
Europe, Middle East and Africa Technical Support:
 Phone: 421 33 790 2910
Japan Customer Focus Center
 Phone: 81-3-5817-1050

ON Semiconductor Website: www.onsemi.com

Order Literature: <http://www.onsemi.com/orderlit>

For additional information, please contact your local Sales Representative