

NIS5431 and NIS5452 Performance and Functionality



ON Semiconductor®

www.onsemi.com

APPLICATION NOTE

Introduction

For many years ON Semiconductor eFuses have been used in a variety of applications such as hard drives, servers, and motherboards. They provide several protection features, they are reliable, and they are continually being improved upon. The NIS5135, NIS5132, and NIS5232 eFuses are some of the time-tested devices that have paved the way for ON Semiconductor's newest eFuse products.

In order to take advantage of technological advancements in the field of power MOSFETs, a new line of eFuses has been developed. The new NIS5431 and NIS5452 are capable of operating with high levels of continuous current and they can operate with either 3.3 V or 5.0 V power rails. The difference between the two devices is that the NIS5431 has a lower overvoltage clamp level and an additional output pin versus the NIS5452. These devices use a compact 3 × 3 mm package, as shown in Figure 1.



**Figure 1. The NIS5431 and NIS5452
Use a 3 × 3 mm Package**

ON Semiconductor's eFuses have several integrated features that make them excellent general purpose circuit protection devices. These include a charge pump, sophisticated overcurrent protection, thermal shutdown, a tristate enable pin, undervoltage lockout, and overvoltage protection with output voltage clamping. The standard pin connections for the NIS5452 are shown in Figure 2.

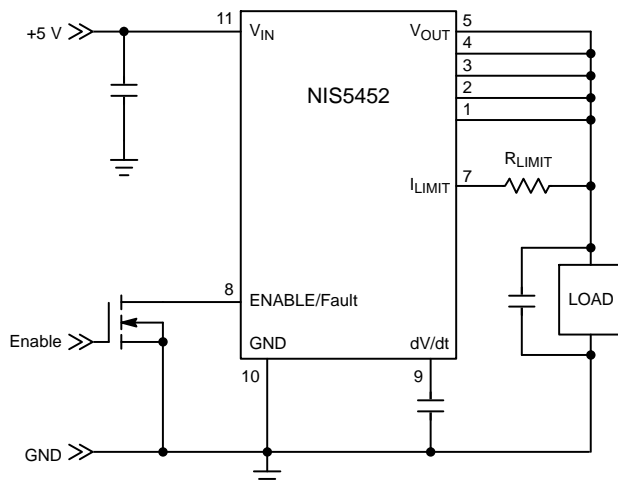

Figure 2. Typical Application Circuit for the NIS5452

RDSon

One critical parameter for an eFuse is its RDSon, which is effectively the resistance between the power supply and the load in normal operation. The RDSon is determined by what type of internal transistor is used and how it is controlled. The NIS5431 and NIS5452 use an integrated high-side n-channel power MOSFET whose gate voltage is boosted with an internal charge pump. The MOSFET technology employed is engineered for very high gain in order to minimize the RDSon. The new NIS5431 and NIS5452 have a typical RDSon of just 33 mΩ, which is less than half that of its predecessor, the NIS5135.

Continuous Current Capability

The low RDSon provides several practical advantages that make the devices more versatile. Figures 3–4 and 5–6 show the NIS5452 operating on its evaluation board with 2.5 and 5.0 A, respectively.

At high currents there is minimal voltage dropped across the device. This ensures that plenty of voltage is available to the load and very little power is wasted. For example, at 2.5 A the voltage drop is only 130 mV, and at 5.0 A it is 270 mV.

It also allows for more margin while running at higher ambient temperatures. For example, if the application might have an ambient temperature of 70°C, then the low RDSon become a critical feature. Although eFuses have a maximum operating temperature of 150°C, for best life expectancy of semiconductor devices it is recommended to operate at as low of a temperature as possible.

Another advantage of the low RDSon is that less copper area is required to dissipate heat, because the device operates at a more reasonable temperature. In a space-constrained application like an SSD, there might not be enough copper area to allow the device to reach its true potential. However since the RDSon is low, whatever copper area is available will likely be sufficient.

Should more current be needed, it is possible to parallel multiple copies of the eFuses. As many as four of them can be connected with enable pins tied to each other. When eFuses run in parallel they share current equally due to the positive temperature coefficient of the RDSon.

AND9495/D

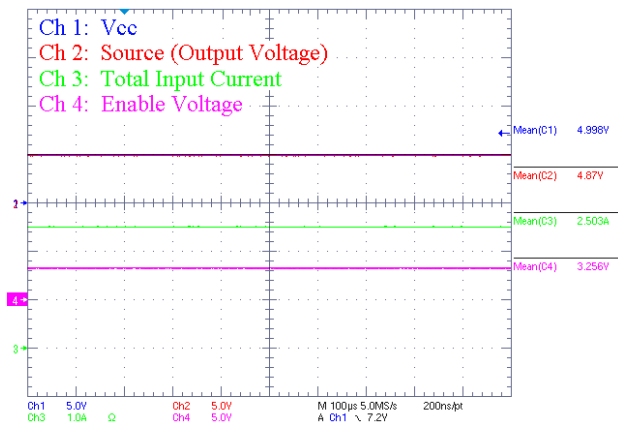

Figure 3. The NIS5452 is Operating with 2.5 A of Current. Note the Voltage Drop from Input (Ch 1: V_{CC}) to Output (Ch 2: Source) is just 130 mV, which is a Consequence of the Low R_{DS(on)} of the Device

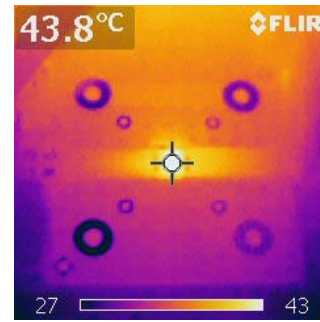

Figure 4. Here is a FLIR Image of the NIS5452 with 2.5 A of Current, Running at Only 43.8° Case Temperature

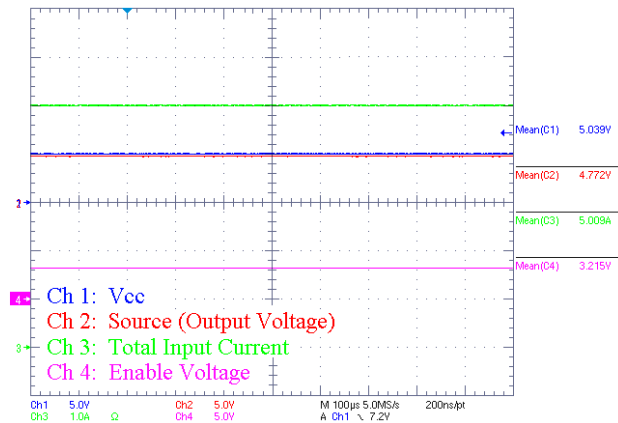

Figure 5. The NIS5452 is Operating with 5 A of Current. In this Case the Voltage Drop across the Device is 270 mV

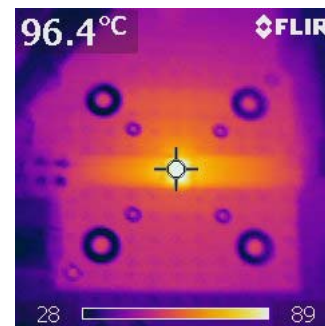

Figure 6. Operating with 5 A, the Case Temperature of the NIS5452 was Measured as 96.4°. This is with a Basic Evaluation Board with the Equivalent of about 1000 mm² of Copper

Current Limiting

The NIS5431 and NIS5452 are capable of operating with up to 5 A, but also have current limiting as a feature in case load faults occur. The current limit circuit employed is a SenseFET architecture, which is very efficient. While other topologies employ a current sense resistor that bleeds current to ground or is in-line with the main current path, this topology just uses a small portion of the current passing through the eFuse itself. The current limit is adjustable with the external resistor called R_{LIMIT}.

The device has two different current limit levels called I_{LIM(SC)} and I_{LIM(OL)} that apply depending on the region of operation of the internal power MOSFET. I_{LIM(SC)} applies whenever the power MOSFET is in saturation. Therefore, when V_{CC} is 5 V any output voltage below about 4 V will make I_{LIM(SC)} applicable. A simple example is when the output is shorted to ground and the device is turned on. This can be seen in Figure 7. In this case the device enters current limit and goes into thermal shutdown 25 ms later as shown in Figure 8.

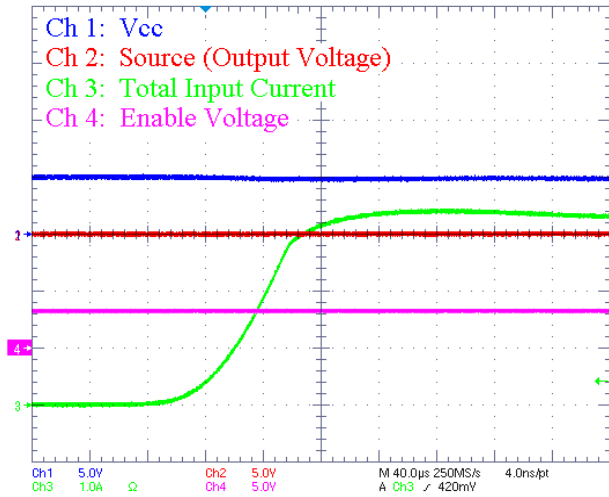

Figure 7. The NIS5452 has its Output Shorted. Ch3 (Green) Shows the Current Rising to the $I_{LIM(SC)}$ Level as the Device is Starting. Not Shown is the Enable being Brought High to Initiate the Sequence. The Time Scale is 40 μs per Division and the Current Limit is about 3.3 A

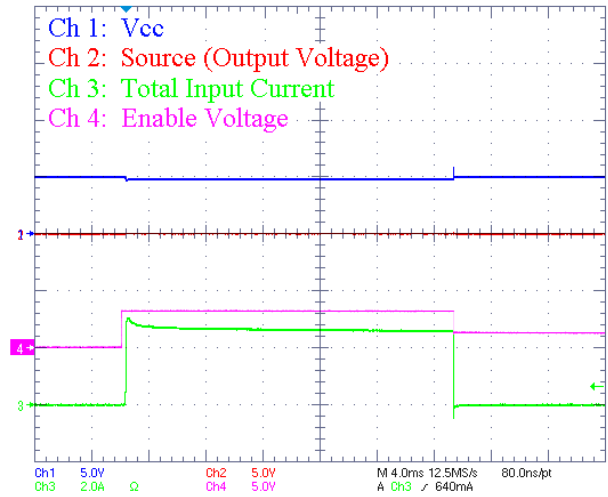

Figure 8. The NIS5452 is Turned On into a Short. In this Test, the Enable Pin Voltage is Temporarily Held Low with a Switch. Shortly after the Switch is Released, the Enable Pin Voltage Rises, and the Device Turns On. The Current Limit Applies for about 25 ms until the Thermal Shutdown Level is Reached. The Time Scale is 4 ms per Division

$I_{LIM(OL)}$ is the current limit when the internal power MOSFET is in the triode region, so it applies during normal operation. $I_{LIM(SC)}$ is the more important of the two current limits. The hardware designer must set the R_{LIMIT} such that $I_{LIM(SC)}$ is a good margin above the expected normal operating current. If there is insufficient margin, the eFuse would not allow the normal load current to flow. The eFuses have hardly any temperature dependence on this parameter to help hardware designers maintain that critical margin.

After the $I_{LIM(OL)}$ is reached, the devices will transition to the $I_{LIM(SC)}$ level. If the fault persists, the eFuse will eventually become hot enough to enter thermal shutdown. Thermal shutdown takes a few milliseconds to happen.

The precise $I_{LIM(OL)}$ level depends on the temperature of the device and the nature of the fault. To prevent thermal runaway, $I_{LIM(OL)}$ is engineered with a negative temperature coefficient. Also, as can be seen from Figure 9 and Figure 10 below, the current is limited at a lower level depending on how long the device has been running with high current. There is an added benefit in some applications that short bursts of current may not trip the device. This will allow continued operation when needed but will prevent damage to traces and connectors from heating. Figures 9 and 10 show $I_{LIM(OL)}$ for two faults of different speeds.

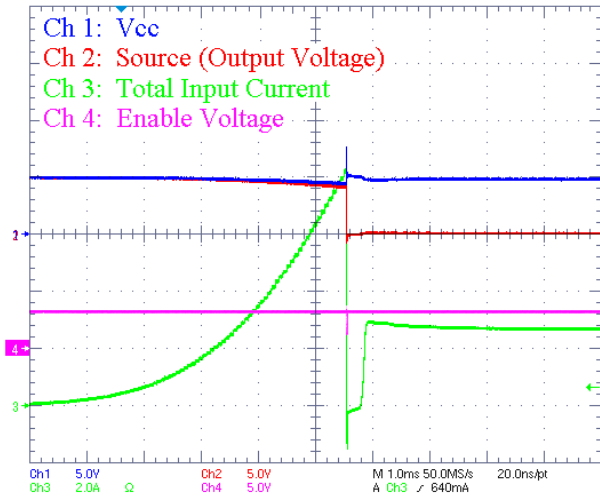

Figure 9. This Waveform Shows the NIS5452 $I_{LIM(OL)}$ Characteristic with a Current Ramp Time of Approximately 3 ms. The Ramp is Created by Slowly Increasing the Gate Voltage of a MOSFET Connected between eFuse Output and Ground. After the Device Reaches the Overload Current Limit, it Settles to the $I_{LIM(SC)}$ Level. The Time Scale is 1 ms per Division

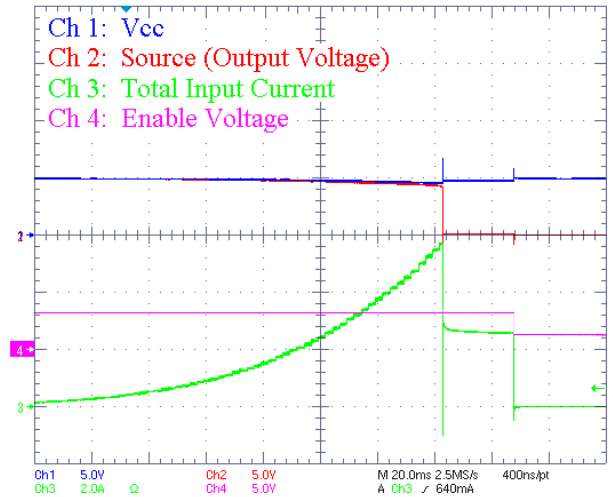

Figure 10. NIS5452 $I_{LIM(OL)}$ for a 75 ms Ramp Time. Note that $I_{LIM(OL)}$ Occurs at a Lower Current Level when the Fault is Slower. In Figure 9 it was about 8 A and in Figure 10 it is about 6 A. The Time Scale is 20 ms per Division

Thermal Shutdown

The NIS5452 and NIS5431 enter thermal shutdown when the internal die temperature reaches 175°C. While in thermal shutdown, the device is latched off and the Enable/Fault pin is at 1.4 V. This 1.4 V signal may be used to signal other eFuses to turn off, or it can be read by control logic. There are two ways to turn the eFuse back on after a fault has occurred. The first is to cycle the input voltage (VCC pin) of the eFuse. The other is to temporarily ground the enable pin and then release it.

UVLO

The undervoltage lockout feature of the eFuse prevents the power MOSFET from being on when the input voltage is abnormally low. It contains a hysteresis feature so that the lockout level is different turning on versus turning off. Figures 11 and 12 demonstrate the UVLO feature.

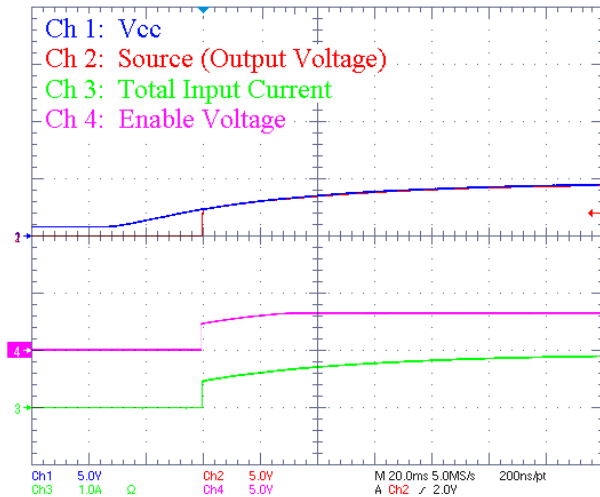

Figure 11. The NIS5452 Turning On Past UVLO

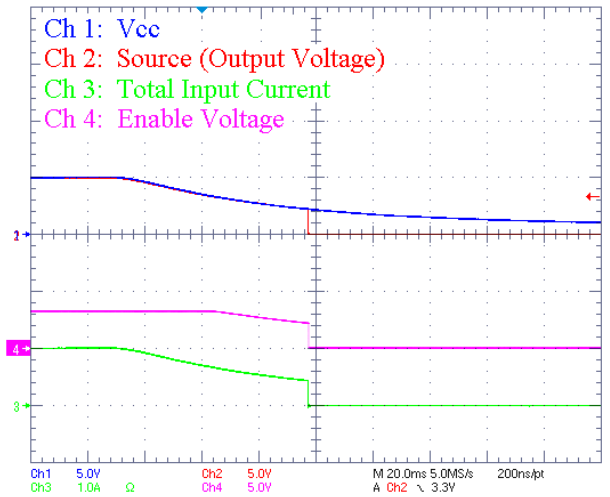

Figure 12. The NIS5452 Turning Off Past UVLO

Overvoltage Protection

The NIS5431 and NIS5452 feature overvoltage protection, commonly referred to in eFuse jargon as V_{clamp} . The overvoltage threshold is typically 3.85 V for the NIS5431 and 5.85 V for the NIS5452. Whenever the input voltage rises, the output voltage is prevented from going above the V_{clamp} level. After some time the difference between input and output voltage will cause the device to enter into thermal shutdown. The response time of the overvoltage protection circuit has been carefully engineered to ensure that it does not oscillate or cause the output voltage to decrease. Figure 13 shows an overvoltage event with the NIS5452.

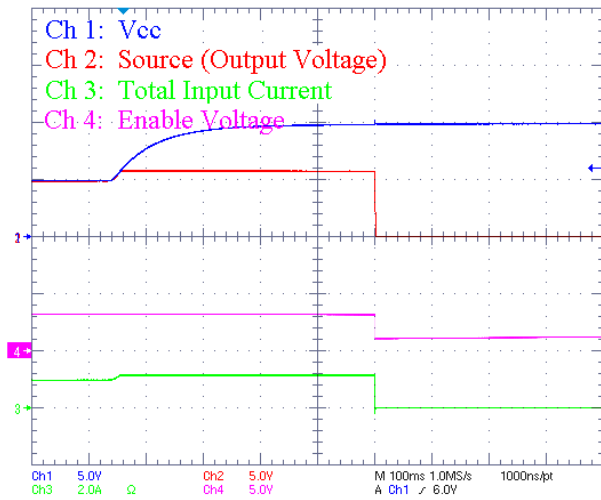

Figure 13. NIS5452 Overvoltage with a 1 A Load. The Output Voltage is Stable and the eFuse Enters Thermal Shutdown 450 ms after the Overvoltage Event Begins. The Time Scale is 100 ms per Division

Inrush Current

There are two types of inrush current to be considered when analyzing an eFuse. The first inrush current to be considered occurs when the input voltage is increased rapidly. As can be seen in Figure 14, the inrush current during this test (V_{CC} rises from 0 to 7.5 V in 40 ns) is virtually non-existent. Other devices show inrush current orders of magnitude higher.

The other type of inrush current is that from the charging of an output capacitor. In this case the controlled slew rate feature of the eFuse serves as an inrush current limiter. Using the classic $i = C(dv/dt)$ equation one can calculate the current passing through the eFuse during this test. In this case a 1 nF capacitor was connected to the dv/dt pin to provide a long delay. The output capacitor used was a 10 μ F for this test. If a very large capacitor (such as 20 mF is connected to the output), the device will still limit the inrush current using either the slow ramp or for the initial portion the short circuit current limit, $I_{LIM(SC)}$.

Bias Current

The NIS5452 and NIS5431 have special circuitry to minimize bias current. For a typical unit the bias current is under 100 μ A when the device is shut down. This is important for battery-powered applications (such as inside a laptop computer) so that charging is not needed so often.

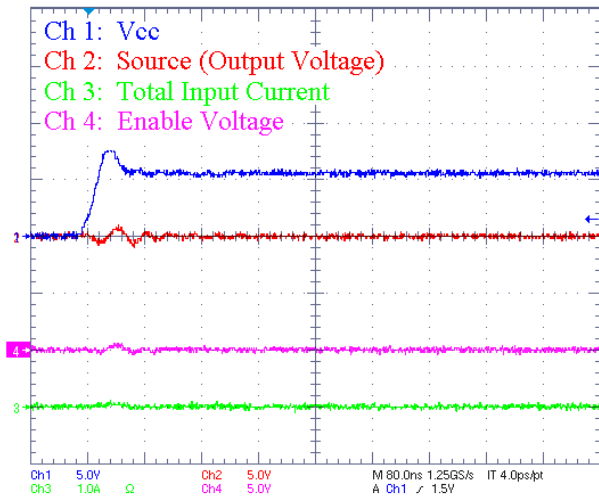

Figure 14. NIS5452 Inrush Current with the Input Voltage Rising in 40 ns. The Time Scale is 80 ns per Division

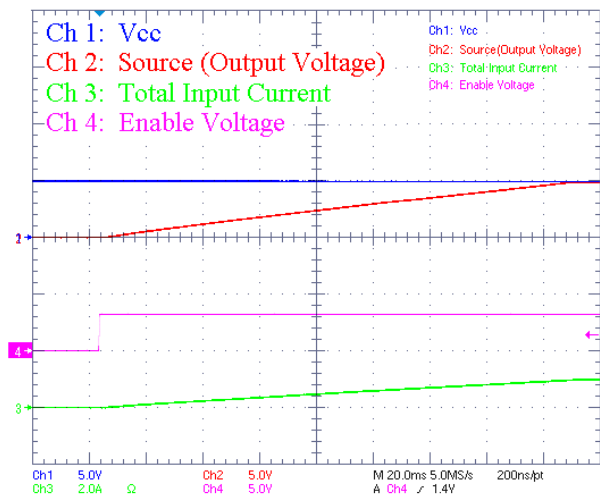

Figure 15. NIS5452 Inrush Current is Minimized when the Output Voltage Ramps Up. The Time Scale is 20 ms per Division

AND9495/D

Conclusion

The NIS5452 and NIS5431 can be tested on a standard evaluation board as shown in Figure 16. The evaluation board features several peripheral components that assist

testing. Please visit www.onsemi.com and search NIS5452MT1GEVB or contact your local ON Semiconductor sales representative for evaluation boards and samples.

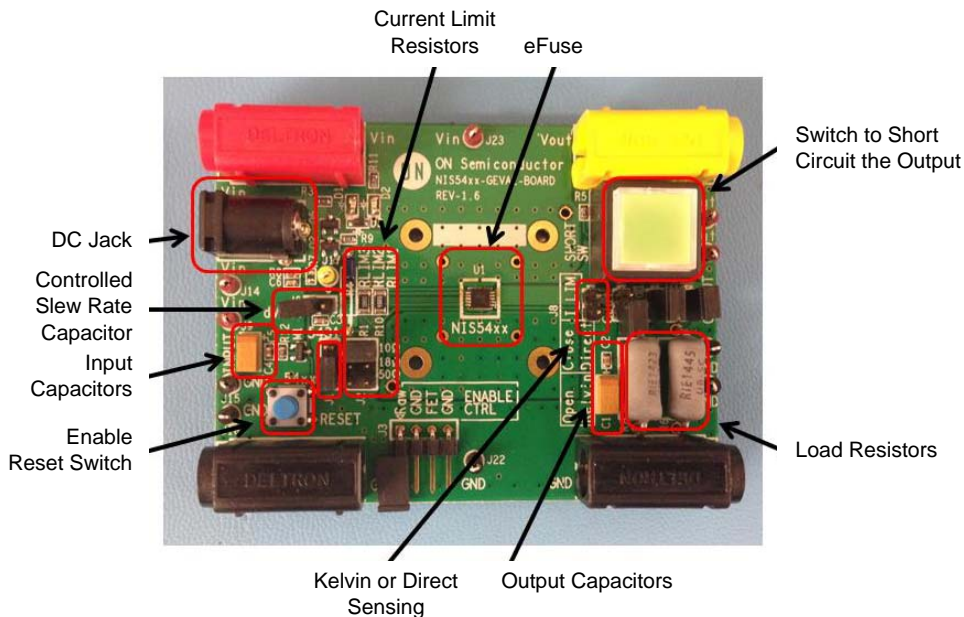



Figure 16. The Evaluation Board for the NIS5452 and NIS5431. Several Peripheral Components are Included to Help Demonstrate the Features of the eFuse

ON Semiconductor and  are trademarks of Semiconductor Components Industries, LLC dba ON Semiconductor or its subsidiaries in the United States and/or other countries. ON Semiconductor owns the rights to a number of patents, trademarks, copyrights, trade secrets, and other intellectual property. A listing of ON Semiconductor's product/patent coverage may be accessed at www.onsemi.com/site/pdf/Patent-Marking.pdf. ON Semiconductor reserves the right to make changes without further notice to any products herein. ON Semiconductor makes no warranty, representation or guarantee regarding the suitability of its products for any particular purpose, nor does ON Semiconductor assume any liability arising out of the application or use of any product or circuit, and specifically disclaims any and all liability, including without limitation special, consequential or incidental damages. Buyer is responsible for its products and applications using ON Semiconductor products, including compliance with all laws, regulations and safety requirements or standards, regardless of any support or applications information provided by ON Semiconductor. "Typical" parameters which may be provided in ON Semiconductor data sheets and/or specifications can and do vary in different applications and actual performance may vary over time. All operating parameters, including "Typicals" must be validated for each customer application by customer's technical experts. ON Semiconductor does not convey any license under its patent rights nor the rights of others. ON Semiconductor products are not designed, intended, or authorized for use as a critical component in life support systems or any FDA Class 3 medical devices or medical devices with a same or similar classification in a foreign jurisdiction or any devices intended for implantation in the human body. Should Buyer purchase or use ON Semiconductor products for any such unintended or unauthorized application, Buyer shall indemnify and hold ON Semiconductor and its officers, employees, subsidiaries, affiliates, and distributors harmless against all claims, costs, damages, and expenses, and reasonable attorney fees arising out of, directly or indirectly, any claim of personal injury or death associated with such unintended or unauthorized use, even if such claim alleges that ON Semiconductor was negligent regarding the design or manufacture of the part. ON Semiconductor is an Equal Opportunity/Affirmative Action Employer. This literature is subject to all applicable copyright laws and is not for resale in any manner.

PUBLICATION ORDERING INFORMATION

LITERATURE FULFILLMENT:

Literature Distribution Center for ON Semiconductor
19521 E. 32nd Pkwy, Aurora, Colorado 80011 USA
Phone: 303-675-2175 or 800-344-3860 Toll Free USA/Canada
Fax: 303-675-2176 or 800-344-3867 Toll Free USA/Canada
Email: orderlit@onsemi.com

N. American Technical Support: 800-282-9855 Toll Free USA/Canada
Europe, Middle East and Africa Technical Support: Phone: 421 33 790 2910
Japan Customer Focus Center Phone: 81-3-5817-1050

ON Semiconductor Website: www.onsemi.com
Order Literature: <http://www.onsemi.com/orderlit>

For additional information, please contact your local Sales Representative